

| REVISIONS | | | | |
|-----------|-----|------------------|-----------|------------|
| REV | ECO | DESCRIPTION | DATE | BY APPR |
| A1 | - | RELEASED DRAWING | Jul-16-18 | Flan Tommy |

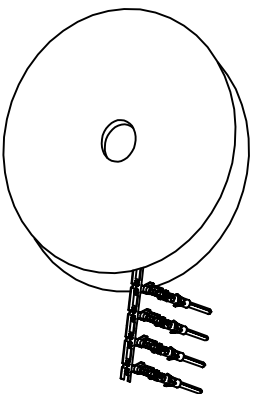

CONTACT ORIENTATION ON ROLL(3000PCS/COIL)

NOTES : (UNLESS OTHERWISE SPECIFIED)
1. MATERIAL :

- 1.1. CONTACT BODY : COPPER ALLOY.
- 1.2. OUTER SPRING : STAINLESS STEEL.

2. SPECIFICATIONS :

- 2.1 CURRENT RATING : 13A MAX.
- 2.2 TERMINATION TYPE : CRIMPING.
- 2.3 WIRE RANGE : 18~16AWG.
- 2.4 WIRE INSULATION DIA(MAX) : ϕ 3.2mm.

3. RoHS COMPLIANT.

4. ALL DIMENSIONS ARE FOR REFERENCE USE ONLY.

5. AVAILABLE TOOLS :

- 5.1 HAND CRIMPER : MFX-3954.
- 5.2 CRIMP APPLICATOR : MFX-3957.
- 5.3 EXTRACTION TOOL : QXRT16.

| P/N | CONTACT PLATING(MATING AREA) |
|-----------|-------------------------------------|
| SP16M2T | TIN PLATING OVER NICKEL. |
| SP16M2N | NICKEL PLATING OVER COPPERIZE. |
| SP16M2F | GOLD FLASH PLATING OVER NICKEL. |
| SP16M2G5 | 5 μ "GOLD PLATING OVER NICKEL. |
| SP16M2G10 | 10 μ "GOLD PLATING OVER NICKEL. |
| SP16M2G15 | 15 μ "GOLD PLATING OVER NICKEL. |
| SP16M2G30 | 30 μ "GOLD PLATING OVER NICKEL. |

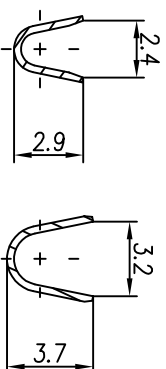
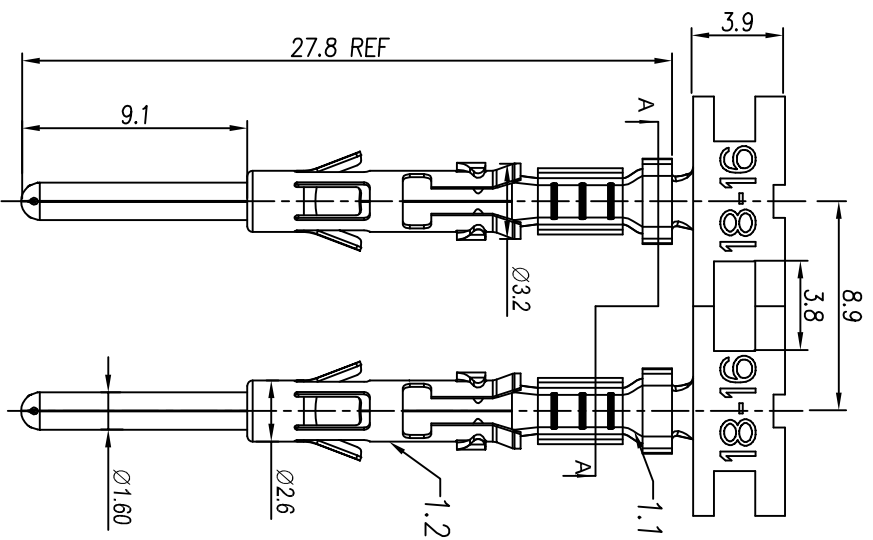

SECTION A-A

| QUANTITY | PART NUMBER | DESCRIPTION | ITEM |
|--|-------------|---|------|
| MATERIALS LIST | | | |
| UNLESS OTHERWISE SPECIFIED 1) All dimensions are in millimeters. 2) Tolerances are as follows: Fractions, 1/16" 1 PL, DEC 20, 93 3 PL, DEC 20, 08 3) Note reference = | | | |
| PROCESS SPECIFICATIONS: MATERIAL SPECIFICATIONS: CUSTOMER: Tommy APPROVAL: Jul-16-18 | | THIS DRAWING IS SUPERSEDED FOR: SPECIFICATIONS AND PERFORMANCE DATA THE MANUFACTURING AND/OR ASSEMBLY OF THIS DRAWING IS THE PROPERTY OF AMPHENOL CORPORATION. NO RIGHTS OF REPRODUCTION ARE GRANTED. ALL MANUFACTURING VARIATIONS: NORMAL | |
| DRAWN: Flan CHECKED: Jod ENGINEER: Tommy APPROVAL: Jul-16-18 | | SIZE: B TYPE: C- DWG NO: SP16M2XX REVISION: A1 | |
| Amphenol Sine Systems - www.amphenol-sine.com 44724 Morley Drive Clinton Township, MI 48036 ECO-MATE PIN CONTACT, STAMPED, 18-16AWG, SIZE 16 | | | |
| SCALE: NONE | SHEET: 1 | OF: 1 | |