

REVISIONS				
P	LTR	DESCRIPTION	DATE	APVD
A2		DESCRIPTION CORRECTED FROM SOLDER TO SCREW TERMINAL IN TITLE BLOCK	13NOV2014	CR JK
A3		1-2271111-1, 1-2271111-2, 2-2271111-1, 2-2271111-2, 3-2271111-1, 8-2271111-1 DISCONTINUED	23SEP2017	TJ NG

1 MATERIAL: ITEM NO. 1: HOUSING - ZINC DIE CASTING, NICKEL PLATED  
 ITEM NO. 2: CONTACT BODY - PA  
 ITEM NO. 3: CONTACT - CuZn  
 CONTACT FINISH - Au

2 ALL DIMENSIONS ARE FOR NOMINAL REFERENCE ONLY UNLESS OTHERWISE STATED

3 MEASUREMENT REFERENCE ONLY

4 PACKAGING: 1 PIECE IN A BAG

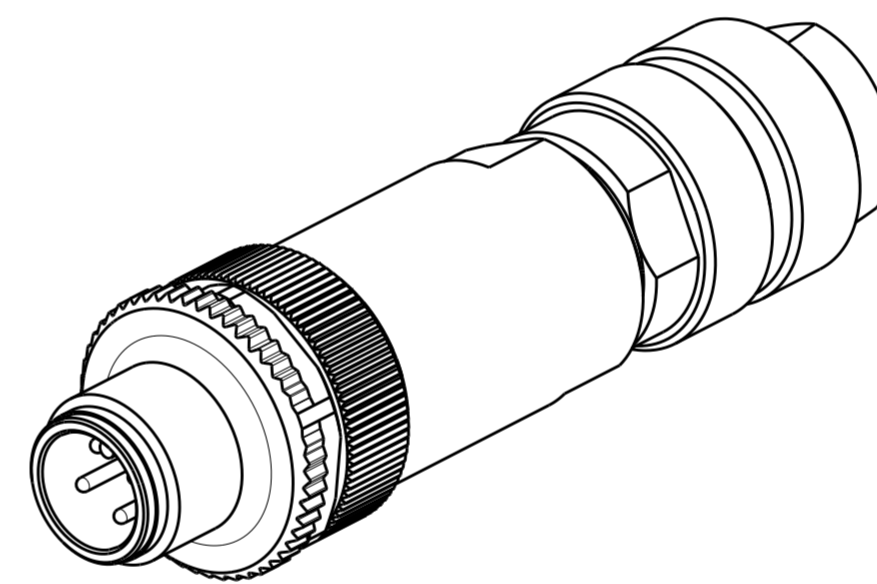
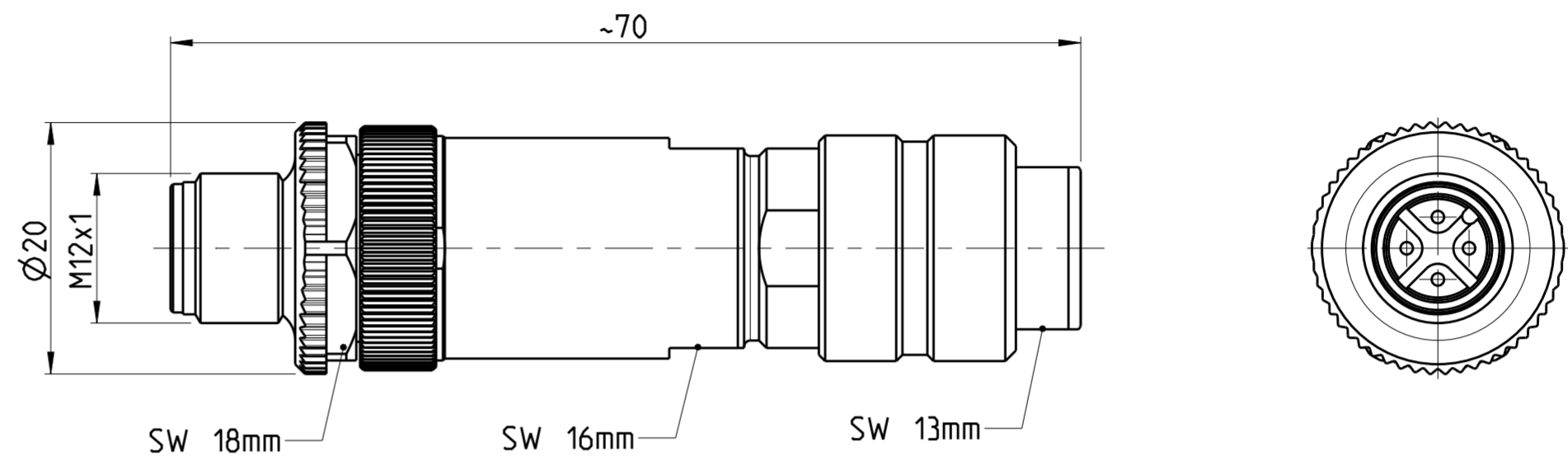

TECHNICAL DATA	3-2271111-2	4-2271111-2	5-2271111-2	6-2271111-2
RATED VOLTAGE	250V	125V	60V	30V
RATED IMPULSE VOLTAGE	2500V	1500V	800V	500V
POLLUTION DEGREE	3	3	3	3
OVERVOLTAGE CATEGORY	II	II	II	II
MATERIAL GROUP	II	II	II	II
RATED CURRENT	4A	4A	2A	2A
VOLUME RESISTIVITY	≤ 3mΩ	≤ 3mΩ	≤ 3mΩ	≤ 3mΩ
DEGREE OF PROTECTION	IP67	IP67	IP67	IP67
UPPER TEMPERATURE	+85 °C	+85 °C	+85 °C	+85 °C
LOWER TEMPERATURE	-40 °C	-40 °C	-40 °C	-40 °C

3-2 AS SHOWN  
WIE GEZEICHNET

PIN ARRANGEMENT  
A-CODING

3-2271111-2	4-2271111-2	5-2271111-2	6-2271111-2

6-8	24 / 0.25mm <sup>2</sup>	⚠	12	6-2271111-2
5-8	20 / 0.50mm <sup>2</sup>	⚠	8	5-2271111-2
5-8	18 / 0.75mm <sup>2</sup>	⚠	5	4-2271111-2
5-8	18 / 0.75mm <sup>2</sup>	⚠	4	3-2271111-2
CABLE FEED-THROUGH mm	WIRES AWG / mm <sup>2</sup>	MATERIAL	NUMBER OF POLES	TE-PART-NO.

DIESE ZEICHNUNG IST EIN KONTROLLIERTES DOKUMENT. BEMASSUNGEN UND TOLERANZEN GEMAESS GPS (ISO STANDARDS).		DWN YASHKUMAR 04 JUN 2014	
THIS DRAWING IS A CONTROLLED DOCUMENT. DIMENSIONING AND TOLERANCING PER GPS (ISO STANDARDS).		CHK M.STRELOW 04 JUN 2014	
DIMENSIONS: MASSEINHEITEN: (MM)		APVD C.SCHREITLINGER 04 JUN 2014	
TOLERANCES UNLESS OTHERWISE SPECIFIED: ALLGEMEINTOLERANZEN		NAME	
0 PLC ±	1 PLC ±	M12 MALE STRAIGHT, FIELD INSTALLABLE, SHIELDED CONNECTOR, SCREW TERMINALS, A-CODING	
2 PLC ±	3 PLC ±	SIZE CAGE CODE DRAWING NO	
4 PLC ±	ANGLES/WINKEL ±	A2 00779 C-2271111	
FINISH/OBERFLAECHE/FARBE		RESTRICTED TO MUR FUER	
MATERIAL		Customer Drawing /KUNDENZEICHNUNG	
		SCALE MASSSTAB 2:1 SHEET BLATT 1 OF VON 1 REV A3	

SIZE ISO 14405 (E)