

ATOM RS-232 Kit

SKU:K046



Description

ATOM RS-232 is a TTL-RS232 level-converter designed for use with the M5Atomic module. RS232 is a full-duplex communication protocol standard, which defines the electrical characteristics of the serial communication system. It is a widely used communication protocol in the field of industrial control. MAX232 chip is integrated in the module, which supports bidirectional conversion between TTL level and RS232 level. A DC/DC voltage regulator chip is integrated in the ATOM RS-232, which can directly convert the 12V voltage of the RS232 hub to 5V to supply power for ATOM.

Product Features

- Compatible ATOM Matrix/ATOM Lite
- Built-in DC/DC
- Full-duplex communication

Include

- 1x ATOM RS-232
- 1x ATOM Lite
- 1x Hex Key
- 1x M2*8mm Hexagon socket cup head machine screw
- 1x 18cm TYPE-C Cable

Applications

- RS232 Communication
- Industrial control node

Specification

Specification	Parameter
External port	VH-3.96 4P
level-conversion IC	MAX232
DC-DC	A0Z1282CI
Net weight	26g
Gross weight	36g
Product Size	24*48*18mm
Package Size	54*54*20mm
Case Material	Plastic(PC)

EasyLoader

EasyLoader is a concise and fast program writer, which has a built-in case program related to the product. It can be burned to the main control by simple steps to perform a series of function verification.

[Download Windows Version Easyloader](#)

[Download MacOS Version Easyloader](#)



Description:

Send and receive the message through RS485, LED is on, press the key to send the message

Related Link

- Datasheet
 - [MAX232](#)
 - [AOZ1282CI](#)

Pin Map

ATOM	GPIO22	GPIO19	5V	GND
ATOM RS-232	RX	TX	5V	GND

Schematic

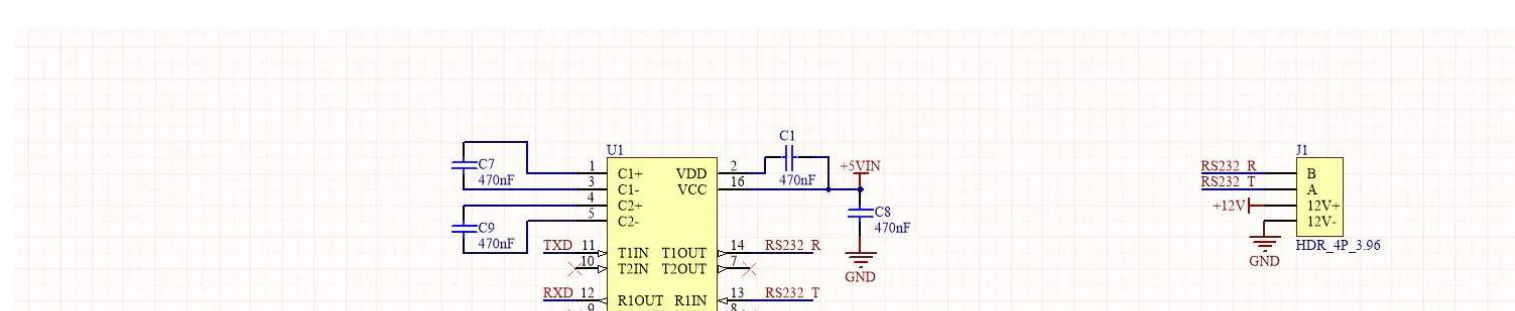

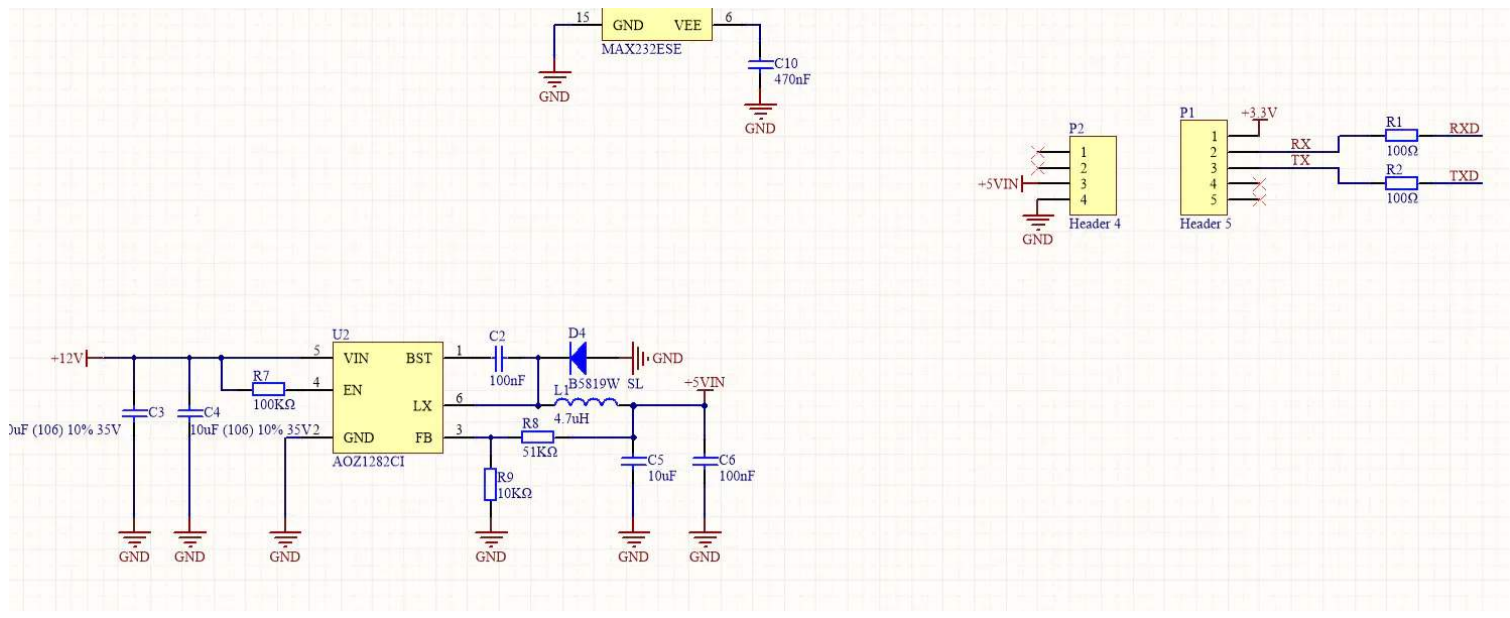

Learn



Roller Mill Remote Scale Display

A practical use of the M5Stack Atom RS232 as part of a remote display.

Example

Arduino

- [Click here to get Arduino example](#)

UIFlow

- [Click here to get UIFlow example](#)

