

HXT45111-3

112Gbps Linear EML Driver

The HXT45111-3 is a single channel linear EML driver, which is a member of the Renesas family of Optical Receiver Transmitter Array (ORTA) products. In conjunction with an EML, a compact linear transmitter can be designed for the next generation of 100G and 200G/400G optical transceivers.

The HXT45111-3 is a low-power, high-performance, single channel linear driver, designed for 112Gbps PAM4 EML-based transceivers. The device is a small form factor (SFF) packaged surface mount device (SMD) with differential input and single-ended output consisting of one 56Gbaud broadband amplifier channel. This design enables it to drive a linear output voltage of 2.0Vpp, suitable for 112G PAM-4 applications.

**Block Diagram**

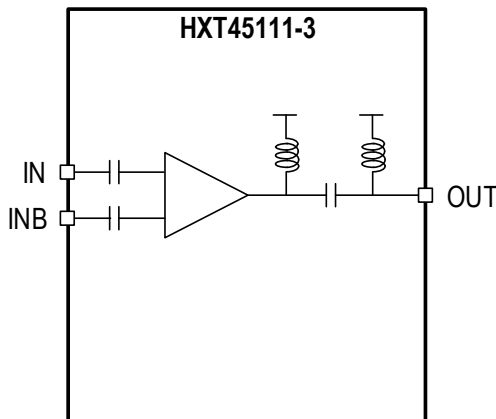

**Features**

- Data rate up to 56Gbaud per channel for PAM-4 applications
- Low power consumption of 250mW per channel
- > 45GHz bandwidth
- Build-in Bias –T and internal high-frequency chokes
- > 10dB dynamic range of gain control
- Peaking on/off control
- Low channel cross-talk
- Small form factor SMD
- Internally DC-blocked RF inputs and outputs

**Applications**

- 100GBASE-DR/FR/LR transmitters
- New generation of 100G Ethernet optical receiver modules: 100G QSFP56 DR, FR, and LR

## IMPORTANT NOTICE AND DISCLAIMER

RENESAS ELECTRONICS CORPORATION AND ITS SUBSIDIARIES (“RENESAS”) PROVIDES TECHNICAL SPECIFICATIONS AND RELIABILITY DATA (INCLUDING DATASHEETS), DESIGN RESOURCES (INCLUDING REFERENCE DESIGNS), APPLICATION OR OTHER DESIGN ADVICE, WEB TOOLS, SAFETY INFORMATION, AND OTHER RESOURCES “AS IS” AND WITH ALL FAULTS, AND DISCLAIMS ALL WARRANTIES, EXPRESS OR IMPLIED, INCLUDING, WITHOUT LIMITATION, ANY IMPLIED WARRANTIES OF MERCHANTABILITY, FITNESS FOR A PARTICULAR PURPOSE, OR NON-INFRINGEMENT OF THIRD PARTY INTELLECTUAL PROPERTY RIGHTS.

These resources are intended for developers skilled in the art designing with Renesas products. You are solely responsible for (1) selecting the appropriate products for your application, (2) designing, validating, and testing your application, and (3) ensuring your application meets applicable standards, and any other safety, security, or other requirements. These resources are subject to change without notice. Renesas grants you permission to use these resources only for development of an application that uses Renesas products. Other reproduction or use of these resources is strictly prohibited. No license is granted to any other Renesas intellectual property or to any third party intellectual property. Renesas disclaims responsibility for, and you will fully indemnify Renesas and its representatives against, any claims, damages, costs, losses, or liabilities arising out of your use of these resources. Renesas' products are provided only subject to Renesas' Terms and Conditions of Sale or other applicable terms agreed to in writing. No use of any Renesas resources expands or otherwise alters any applicable warranties or warranty disclaimers for these products.

(Disclaimer Rev.1.0 Mar 2020)

### Corporate Headquarters

TOYOSU FORESIA, 3-2-24 Toyosu,  
Koto-ku, Tokyo 135-0061, Japan  
[www.renesas.com](http://www.renesas.com)

### Contact Information

For further information on a product, technology, the most up-to-date version of a document, or your nearest sales office, please visit:  
[www.renesas.com/contact/](http://www.renesas.com/contact/)

### Trademarks

Renesas and the Renesas logo are trademarks of Renesas Electronics Corporation. All trademarks and registered trademarks are the property of their respective owners.