

REVISIONS					
P	LTR	DESCRIPTION	DATE	DMN	APVD
E	REV PER ECO	19-019228	4-17-20	CT	DM

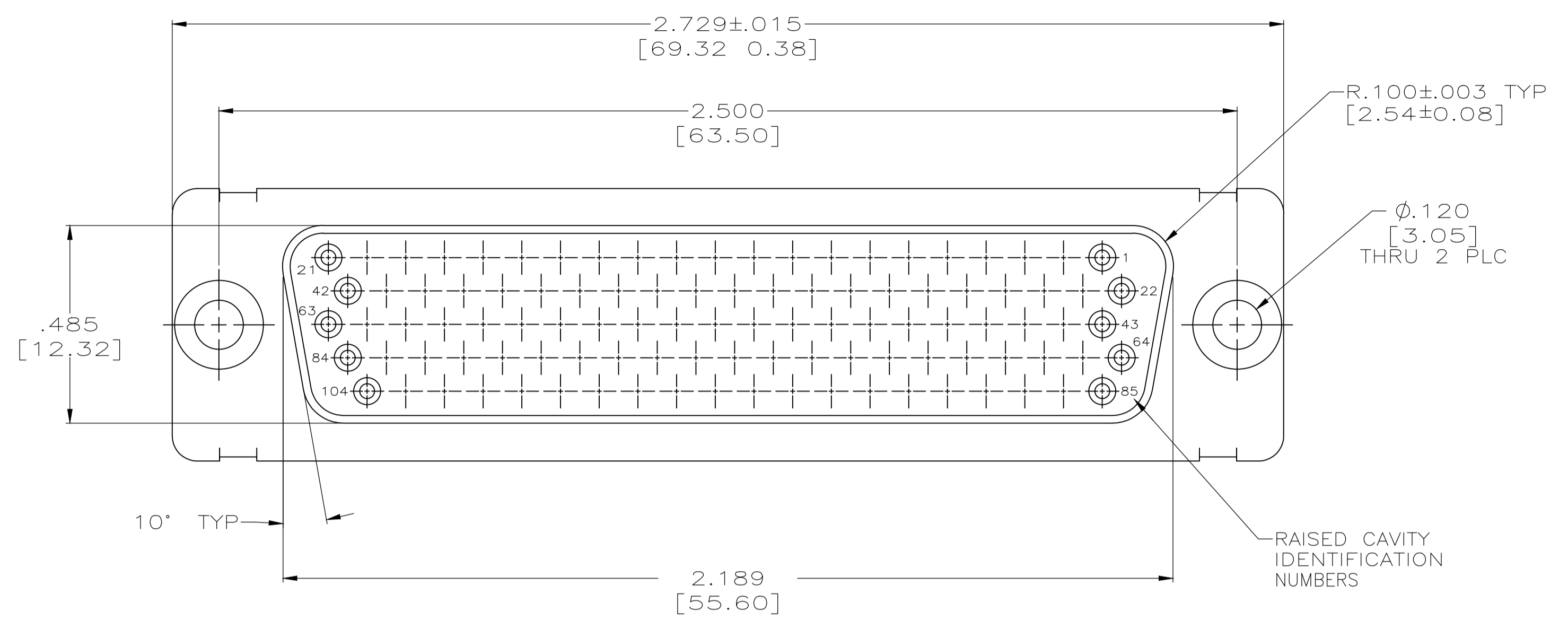

- 1. CONTACTS INCLUDED IN ASSEMBLY.
- CONTACT
 BODY MATL: BERYLLIUM COPPER PER ASTM-B-197.
 BODY FINISH: PLATED GOLD, .000050 MIN THK PER MIL-G-45204 OVER NICKEL, .000050 MIN THK PER QQ-N-290.
 HOOD MATL: STAINLESS STEEL PER ASTM-A-167.
 HOOD FINISH: PASSIVATED PER ASTM-A-380
- MATL: BRASS PER ASTM-B-36.
- FINISH: PLATED GOLD, .000050 MIN THK PER MIL-G-45204 OVER COPPER, .000100 MIN THK PER MIL-C-14550.

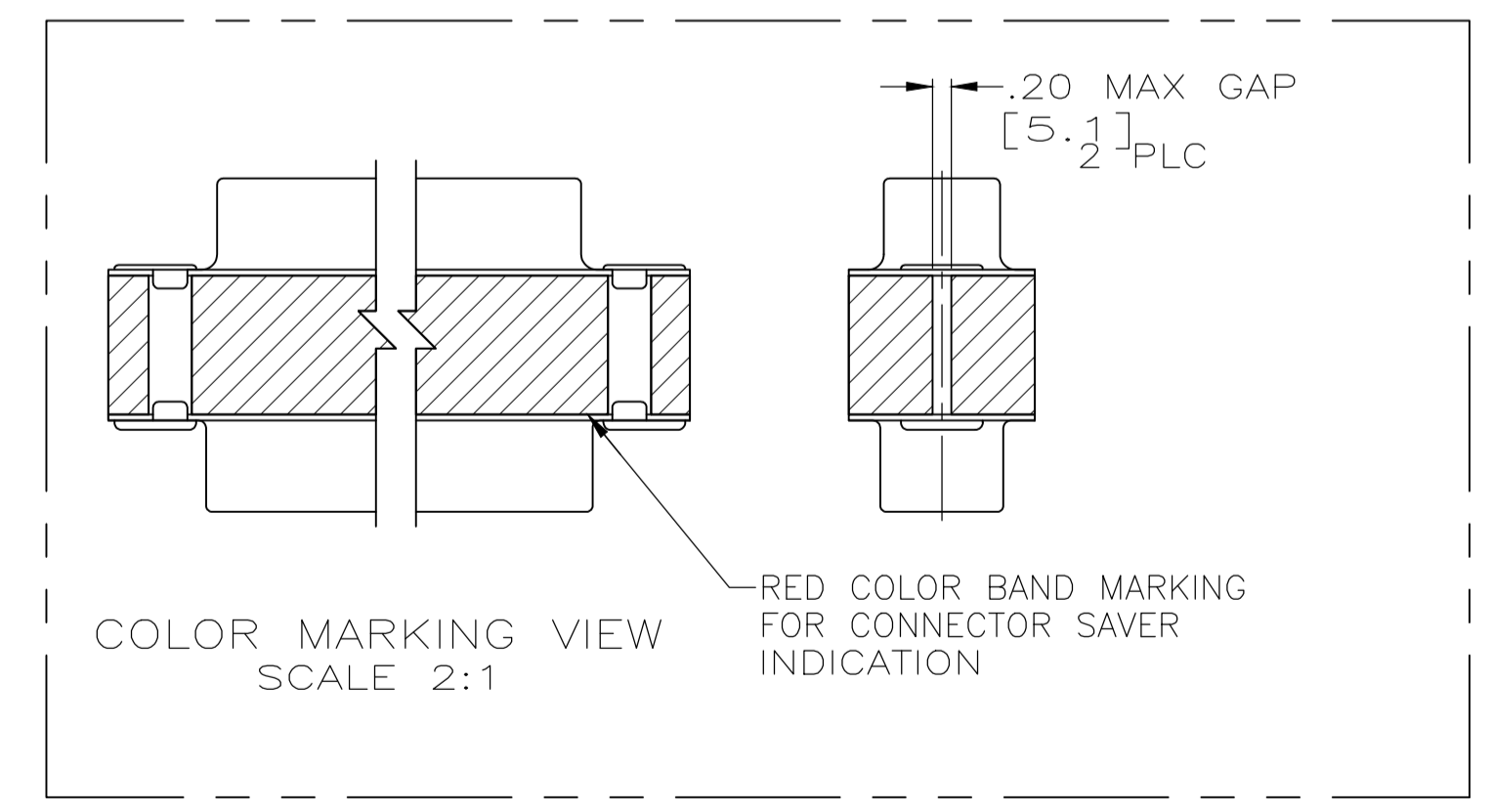
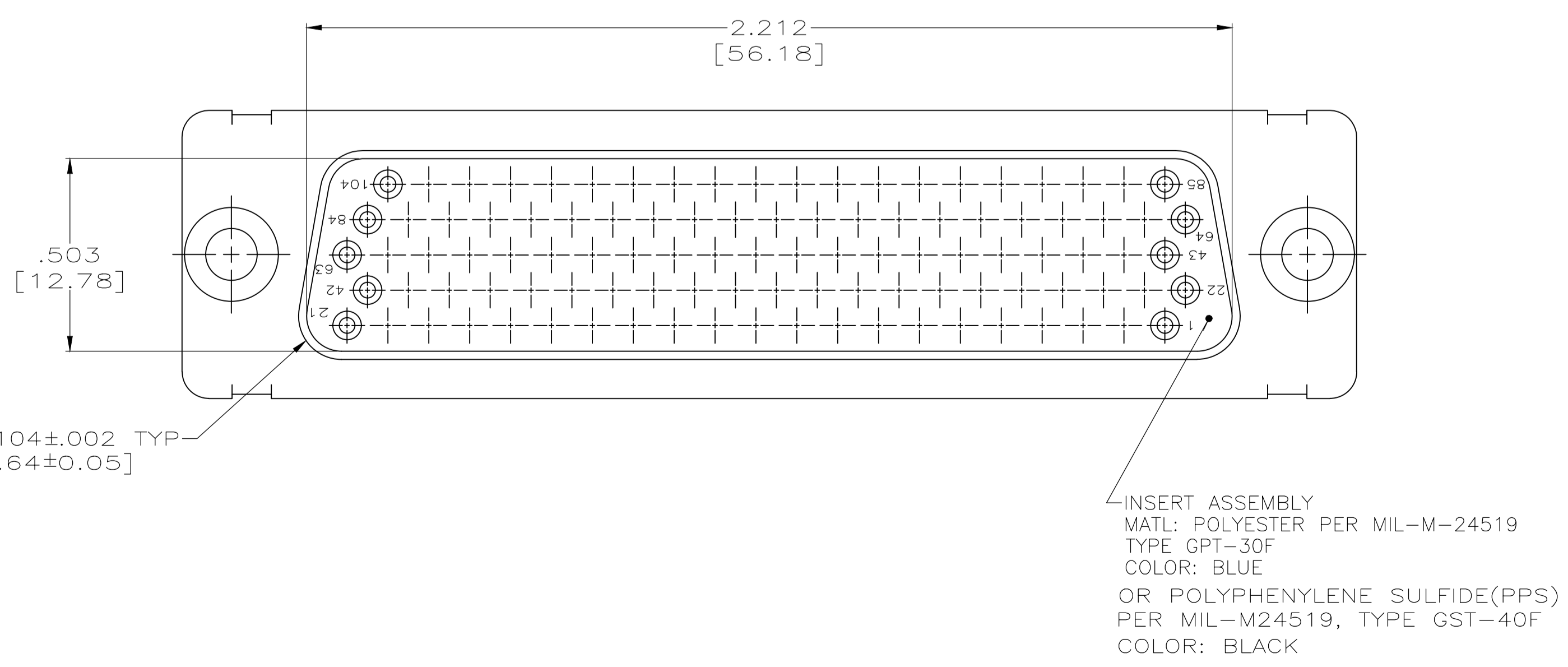
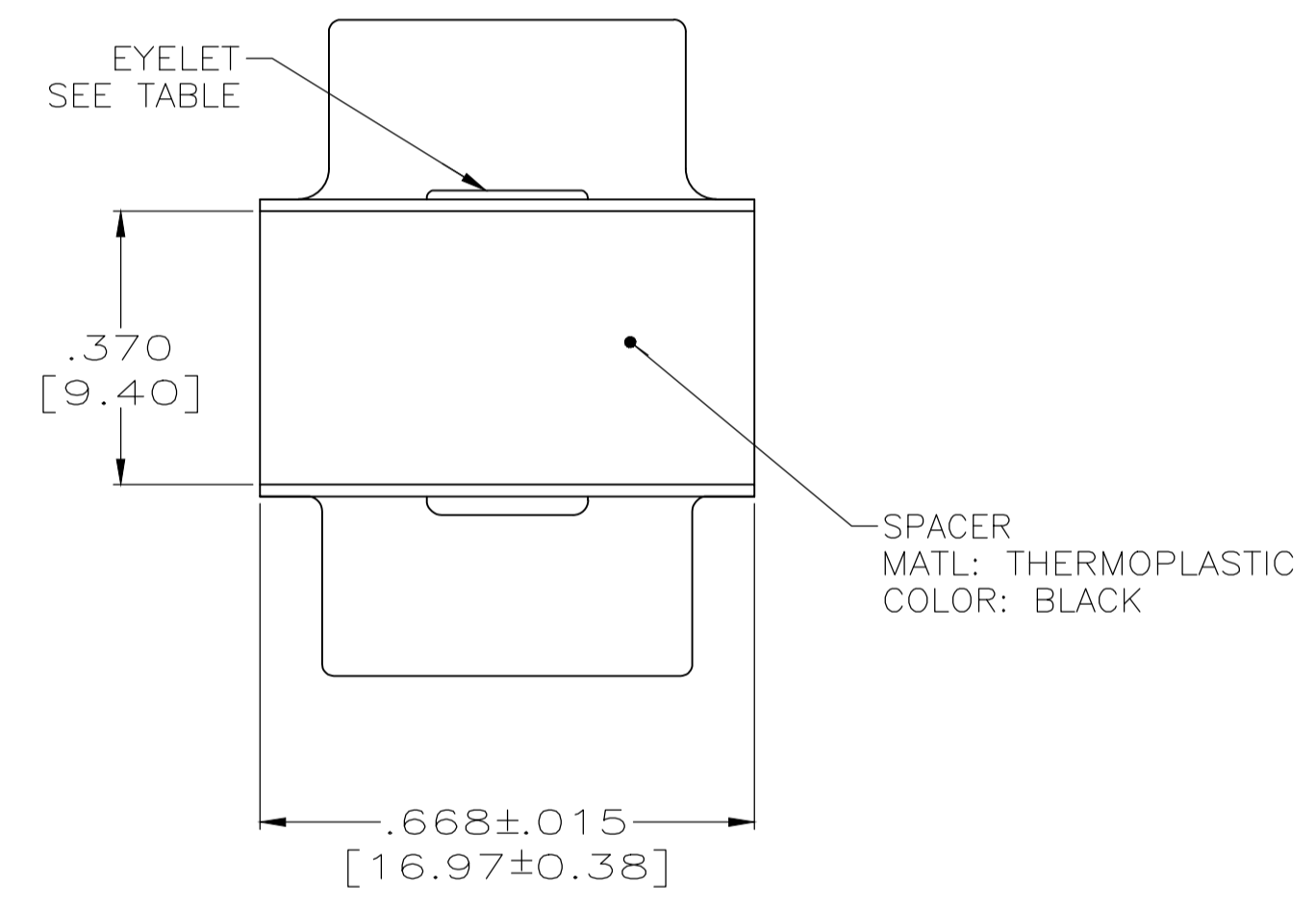
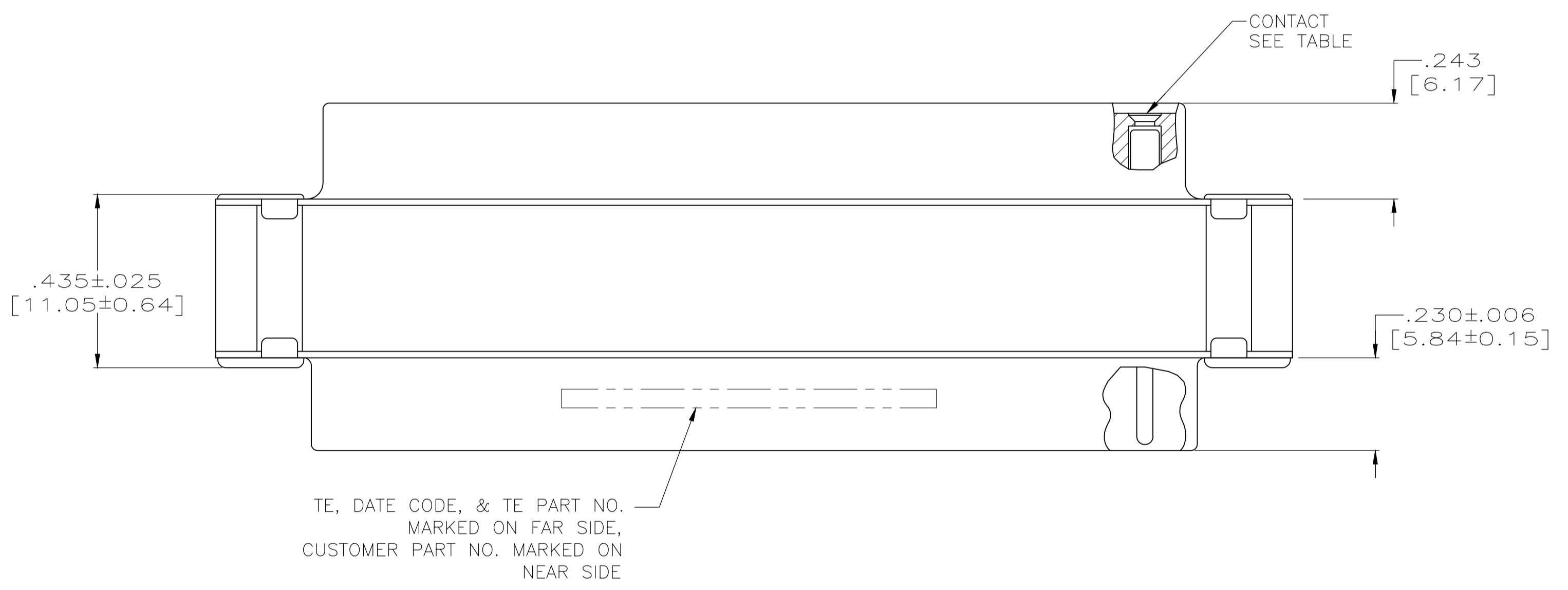

③ ④	③ ④	②	4U884 SOCN R10002677-0011 (1J02-011)	1218313-2
③ ④	③ ④	②		1218313-1
EYELET	SHELLS	CONTACT	CUSTOMER P/N	PART NO.

THIS DRAWING IS A CONTROLLED DOCUMENT.		DIN T. THOMPSON 20AUG98	TE Connectivity	
DIMENSIONS: INCHES		CHK J. NORTON 20AUG98		
TOLERANCES UNLESS OTHERWISE SPECIFIED:		APVD J. NORTON 20AUG98	NAME	
0 PLC ± -		PRODUCT SPEC		
1 PLC ± -		APPLICATION SPEC		
2 PLC ± -		SIZE		
3 PLC ± -		CAGE CODE		
4 PLC ± -		DRAWING NO		
ANGLES ± -		RESTRICTED TO		
MATERIAL	FINISH	WEIGHT 0.000000	A1 00779	1218313
		CUSTOMER DRAWING		

SCALE 4:1 SHEET 1 OF 1 REV E