

TNC 50
Ω

STRAIGHT PLUG

56S107-803N5

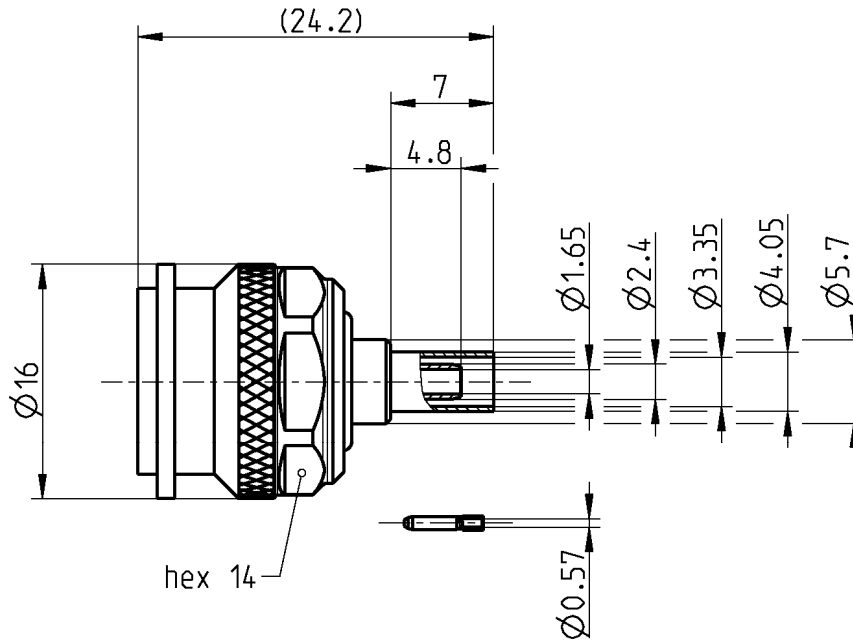

All dimensions are in mm; tolerances according to ISO 2768 m-H

Interface

According to IEC 60169-17, MIL-PRF-39012, DIN EN 122200

Documents

Assembly instruction 51 T

Material and plating

Connector parts	Material	Plating
Center contact	Spring bronze	AuroDur®, gold plated
Outer contact	Brass	Flash white bronze over silver(e.g. Optargen®)
Body	Brass	Flash white bronze over silver(e.g. Optargen®)
Dielectric	PTFE	
Gasket	NeopreneCR 50C6	
Crimping ferrule	Copper	Flash white bronze over silver(e.g. Optargen®)

TNC 50
Ω

STRAIGHT PLUG

56S107-803N5

Electrical data

Impedance	50 Ω
Frequency	DC to 10 GHz
Return loss	≥ 28 dB, DC to 1 GHz ≥ 25 dB, 1 to 2 GHz ≥ 20 dB, 2 to 10 GHz
Insertion loss	≤ 0.05 x √ f [GHz] dB
Insulation resistance	≥ 5 x10 ³ MΩ
Center contact resistance	≤ 1.5 mΩ
Outer contact resistance	≤ 1 mΩ
Test voltage	1500 V rms
Working voltage	500 V rms
Power handling (at 20 °C, sea level, VSWR 1.0)	≤ 80 W @ 2 GHz

- Limitations are possible due to the used cable type -

Mechanical data

Mating cycles	min. 500
Center contact captivation: axial	≥ 15 N
Coupling test torque	max. 1.7 Nm
Recommended torque	0.46 Nm to 0.69 Nm

Environmental data

Temperature range	-45°C to +85°C
Thermal shock	MIL-STD-202, Meth. 107, Cond. B
Corrosion	MIL-STD-202, Meth. 101, Cond. B
Vibration	MIL-STD-202, Meth. 204, Cond. B
Shock	MIL-STD-202, Meth. 213, Cond. G
Moisture resistance	MIL-STD-202, Meth. 106
RoHS	compliant

Tooling

Crimping tool	11W150-000
Crimp insert	11W150-402

Suitable cables

RG 316 /U-d, K02252d

Weight

Weight	12.8 g/pce
--------	------------

While the information has been carefully compiled to the best of our knowledge, nothing is intended as representation or warranty on our part and no statement herein shall be construed as recommendation to infringe existing patents. In the effort to improve our products, we reserve the right to make changes judged to be necessary.

Draft	Date	Approved	Date	Rev.	Engineering change number	Name	Date
Inge Mühlauer	30/11/04	Sa. Krautenbacher	20.03.14	c00	14-0352	T. Krojer	20.03.14
Rosenberger Hochfrequenztechnik GmbH & Co. KG P.O.Box 1260 D-84526 Tittmoning Germany www.rosenberger.de					Tel.: +49 8684 18-0 Fax: +49 8684 18-499 email: info@rosenberger.de		Page 2 / 2