

Optocoupler with Phototransistor Output

Description

The TCLT10.. Series consists of a phototransistor optically coupled to a gallium arsenide infrared-emitting diode in a 4-lead SO6L package.

The elements are mounted on one leadframe using a **coplanar technique**, providing a fixed distance between input and output for highest safety requirements.

Applications

Circuits for safe protective separation against electrical shock according to safety class II (reinforced isolation):

For appl. class I – IV at mains voltage ≤ 300 V

For appl. class I – III at mains voltage ≤ 600 V according to VDE 0884, table 2, suitable for:

Switch-mode power supplies, line receiver, computer peripheral interface, microprocessor system interface.

VDE Standards

These couplers perform safety functions according to the following equipment standards:

VDE 0884

Optocoupler for electrical safety requirements (will be replaced by IEC 747-5-1.2.3)

IEC 950/EN 60950

Office machines (applied for reinforced isolation for mains voltage ≤ 400 V_{RMS})

VDE 0804

Telecommunication apparatus and data processing

IEC 65

Safety for mains-operated electronic and related household apparatus



15231

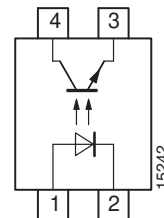

0884



Order Instruction

Ordering Code	CTR Ranking	Remarks
TCLT1000	50 to 600%	4 Pin = Single channel
TCLT1001	40 to 80%	4 Pin = Single channel
TCLT1002	63 to 125%	4 Pin = Single channel
TCLT1003	100 to 200%	4 Pin = Single channel
TCLT1005	50 to 150%	4 Pin = Single channel
TCLT1006	100 to 300%	4 Pin = Single channel
TCLT1007	80 to 160%	4 Pin = Single channel
TCLT1008	130 to 260%	4 Pin = Single channel
TCLT1009	200 to 400%	4 Pin = Single channel

Features

Approvals:

BSI: BS EN 41003, BS EN 60095 (BS 415),
BS EN 60950 (BS 7002),
Certificate number 7081 and 7402

Underwriters Laboratory (UL) 1577 recognized,
file number E-76222 – Double Protection

CSA (C-UL) 1577 recognized
file number E- 76222 - Double Protection

VDE 0884, Certificate number 132473

VDE 0884 related features:

Rated impulse voltage (transient overvoltage)

$V_{IOTM} = 8 \text{ kV peak}$

Isolation test voltage

(partial discharge test voltage) $V_{pd} = 1.6 \text{ kV}$

Rated isolation voltage (RMS includes DC)

$V_{IOWM} = 600 V_{RMS}$ (848 V peak)

Rated recurring peak voltage (repetitive)

$V_{IORM} = 600 V_{RMS}$

Creepage current resistance according
to VDE 0303/IEC 112

Comparative Tracking Index: CTI ≥ 175

Thickness through insulation $\geq 0.75 \text{ mm}$

Creepage distance $> 8 \text{ mm}$

Tested acc. 60950: Am4: 1997 clause 2.9.6.

General features:

Low profile package

CTR offered in 9 groups

Isolation materials according to UL94-VO

Pollution degree 2

(DIN/VDE 0110 / resp. IEC 664)

Climatic classification 55/100/21 (IEC 68 part 1)

Special construction:

Therefore, extra low coupling capacity of

typical 0.2 pF, high **Common Mode Rejection**

Low temperature coefficient of CTR

Coupling System W

**Absolute Maximum Ratings****Input (Emitter)**

Parameter	Test Conditions	Symbol	Value	Unit
Reverse voltage		V_R	6	V
Forward current		I_F	60	mA
Forward surge current	$t_p \leq 10 \mu\text{s}$	I_{FSM}	1.5	A
Power dissipation	$T_{amb} \leq 25 \text{ C}$	P_V	100	mW
Junction temperature		T_j	125	C

Output (Detector)

Parameter	Test Conditions	Symbol	Value	Unit
Collector emitter voltage		V_{CEO}	70	V
Emitter collector voltage		V_{ECO}	7	V
Collector current		I_C	50	mA
Collector peak current	$t_p/T = 0.5, t_p \leq 10 \text{ ms}$	I_{CM}	100	mA
Power dissipation	$T_{amb} \leq 25 \text{ C}$	P_V	150	mW
Junction temperature		T_j	125	C

Coupler

Parameter	Test Conditions	Symbol	Value	Unit
Isolation test voltage (RMS)		V_{IO}	5	kV
Total power dissipation	$T_{amb} \leq 25 \text{ C}$	P_{tot}	250	mW
Operating ambient temperature range		T_{amb}	-40 to +100	C
Storage temperature range		T_{stg}	-40 to +100	C
Soldering temperature		T_{sd}	235	C

Electrical Characteristics ($T_{amb} = 25^{\circ}\text{C}$)

Input (Emitter)

Parameter	Test Conditions	Symbol	Min.	Typ.	Max.	Unit
Forward voltage	$I_F = \pm 50 \text{ mA}$	V_F		1.25	1.6	V
Junction capacitance	$V_R = 0 \text{ V}, f = 1 \text{ MHz}$	C_j		50		pF

Output (Detector)

Parameter	Test Conditions	Symbol	Min.	Typ.	Max.	Unit
Collector emitter voltage	$I_C = 1 \text{ mA}$	V_{CEO}	70			V
Emitter collector voltage	$I_E = 100 \mu\text{A}$	V_{ECO}	7			V
Collector emitter cut-off current	$V_{CE} = 20 \text{ V}, I_f = 0, E = 0$	I_{CEO}		10	100	nA

Coupler

Parameter	Test Conditions	Symbol	Min.	Typ.	Max.	Unit
Collector emitter saturation voltage	$I_F = 10 \text{ mA}, I_C = 1 \text{ mA}$	V_{CEsat}			0.3	V
Cut-off frequency	$V_{CE} = 5 \text{ V}, I_F = 10 \text{ mA}, R_L = 100 \Omega$	f_c		110		kHz
Coupling capacitance	$f = 1 \text{ MHz}$	C_k		0.3		pF

Current Transfer Ratio (CTR)

Parameter	Test Conditions	Type	Symbol	Min.	Typ.	Max.	Unit
I_C/I_F	$V_{CE} = 5 \text{ V}, I_F = 5 \text{ mA}$	TCLT1000	CTR	0.50		6.0	
	$V_{CE} = 5 \text{ V}, I_F = 10 \text{ mA}$	TCLT1001	CTR	0.40		0.8	
	$V_{CE} = 5 \text{ V}, I_F = 10 \text{ mA}$	TCLT1002	CTR	0.63		1.25	
	$V_{CE} = 5 \text{ V}, I_F = 10 \text{ mA}$	TCLT1003	CTR	1.0		2.0	
	$V_{CE} = 5 \text{ V}, I_F = 1 \text{ mA}$	TCLT1001	CTR	0.13	0.30		
	$V_{CE} = 5 \text{ V}, I_F = 1 \text{ mA}$	TCLT1002	CTR	0.22	0.45		
	$V_{CE} = 5 \text{ V}, I_F = 1 \text{ mA}$	TCLT1003	CTR	0.34	0.70		
	$V_{CE} = 5 \text{ V}, I_F = 5 \text{ mA}$	TCLT1005	CTR	0.5		1.5	
	$V_{CE} = 5 \text{ V}, I_F = 5 \text{ mA}$	TCLT1006	CTR	1.0		3.0	
	$V_{CE} = 5 \text{ V}, I_F = 5 \text{ mA}$	TCLT1007	CTR	0.8		1.6	
	$V_{CE} = 5 \text{ V}, I_F = 5 \text{ mA}$	TCLT1008	CTR	1.3		2.6	
	$V_{CE} = 5 \text{ V}, I_F = 5 \text{ mA}$	TCLT1009	CTR	2.0		4.0	

Maximum Safety Ratings (according to VDE 0884) see figure 1

This optocoupler is suitable for safe electrical isolation only within the safety ratings. Compliance with the safety ratings shall be ensured by means of suitable protective circuits.

Input (Emitter)

Parameters	Test Conditions	Symbol	Value	Unit
Forward current		I_{si}	130	mA

Output (Detector)

Parameters	Test Conditions	Symbol	Value	Unit
Power dissipation	$T_{amb} \leq 25\text{ C}$	P_{si}	265	mW

Coupler

Parameters	Test Conditions	Symbol	Value	Unit
Rated impulse voltage		V_{IOTM}	8	kV
Safety temperature		T_{si}	150	C

Insulation Rated Parameters (according to VDE 0884)

Parameter	Test Conditions	Symbol	Min.	Typ.	Max.	Unit
Partial discharge test voltage – Routine test	100%, $t_{test} = 1\text{ s}$	V_{pd}	1.6			kV
Partial discharge test voltage – Lot test (sample test)	$t_{Tr} = 60\text{ s}$, $t_{test} = 10\text{ s}$, (see figure 2)	V_{IOTM}	8			kV
		V_{pd}	1.3			kV
Insulation resistance	$V_{IO} = 500\text{ V}$	R_{IO}	10^{12}			Ω
	$V_{IO} = 500\text{ V}$, $T_{amb} = 100\text{ C}$	R_{IO}	10^{11}			Ω
	$V_{IO} = 500\text{ V}$, $T_{amb} = 150\text{ C}$ (construction test only)	R_{IO}	10^9			Ω

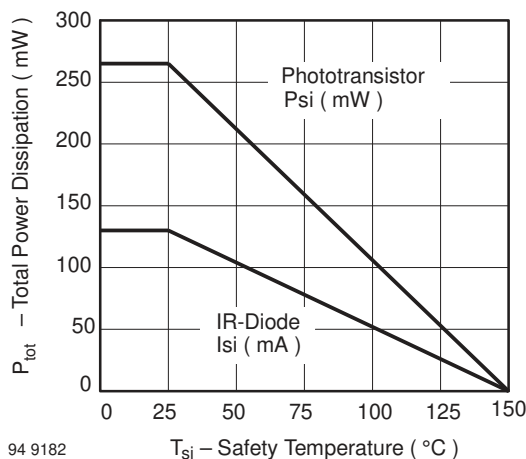

Figure 1. Derating diagram

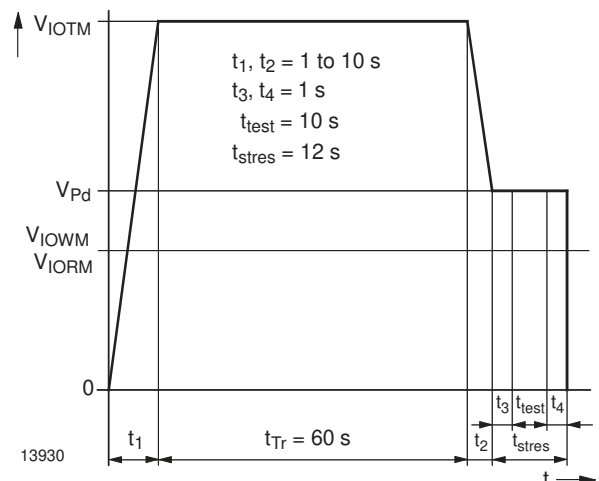

Figure 2. Test pulse diagram for sample test according to DIN VDE 0884

Switching Characteristics

Parameter	Test Conditions	Symbol	Typ.	Unit
Delay time	$V_S = 5\text{ V}$, $I_C = 2\text{ mA}$, $R_L = 100\ \Omega$ (see figure 3)	t_d	3.0	μS
Rise time		t_r	3.0	μS
Turn-on time		t_{on}	6.0	μS
Storage time		t_s	0.3	μS
Fall time		t_f	4.7	μS
Turn-off time		t_{off}	5.0	μS
Turn-on time	$V_S = 5\text{ V}$, $I_F = 10\text{ mA}$, $R_L = 1\text{ k}\Omega$ (see figure 4)	t_{on}	9.0	μS
Turn-off time		t_{off}	10.0	μS

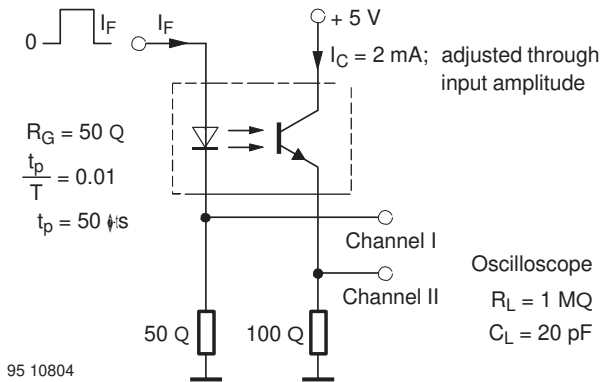

Figure 1. Test circuit, non-saturated operation

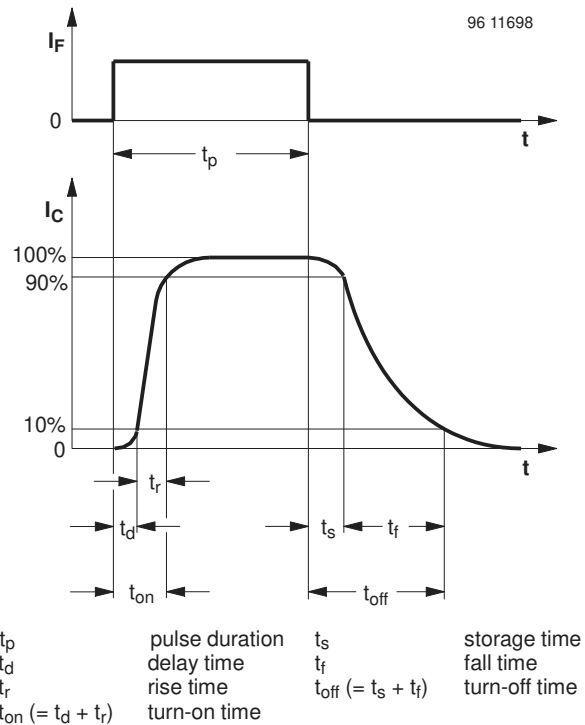

Figure 3. Switching times

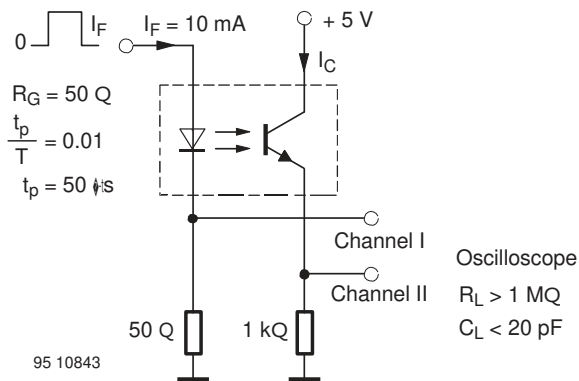

Figure 2. Test circuit, saturated operation

Typical Characteristics ($T_{amb} = 25\text{ C}$, unless otherwise specified)

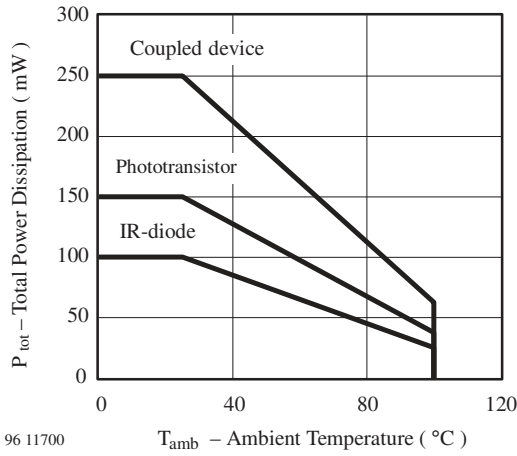

Figure 4. Total Power Dissipation vs. Ambient Temperature

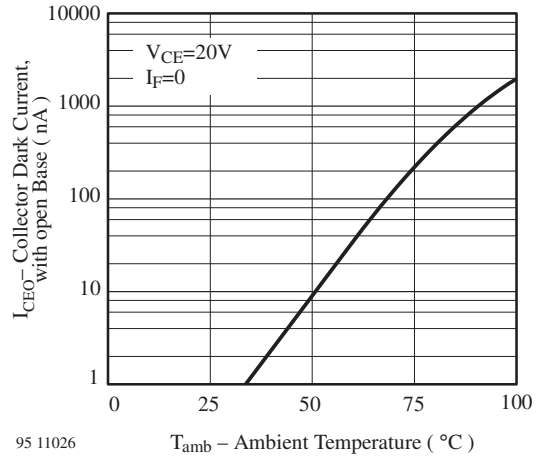

Figure 7. Collector Dark Current vs. Ambient Temperature

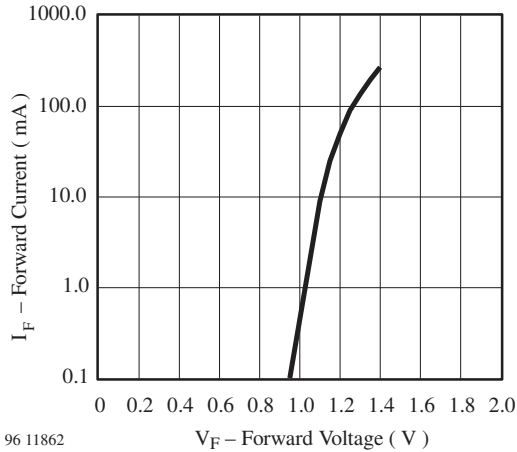

Figure 5. Forward Current vs. Forward Voltage

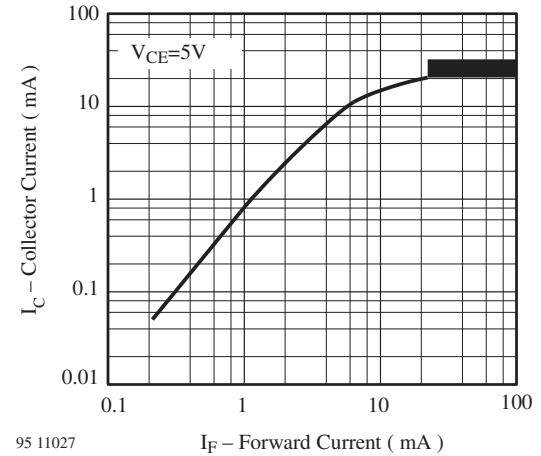

Figure 8. Collector Current vs. Forward Current

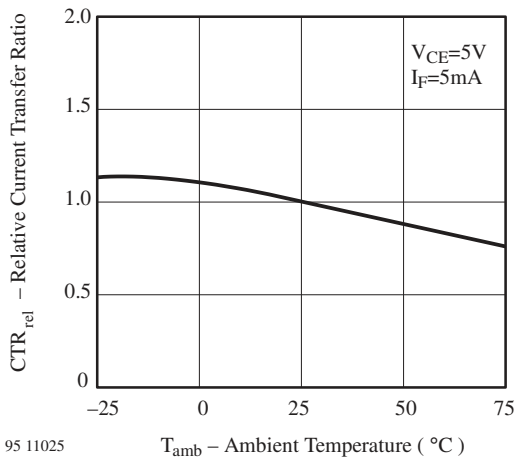

Figure 6. Relative Current Transfer Ratio vs. Ambient Temperature

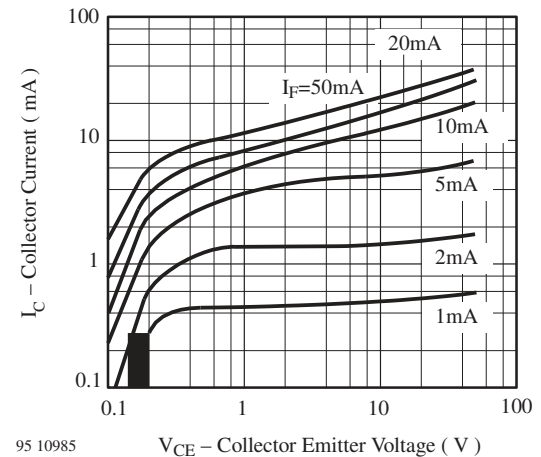
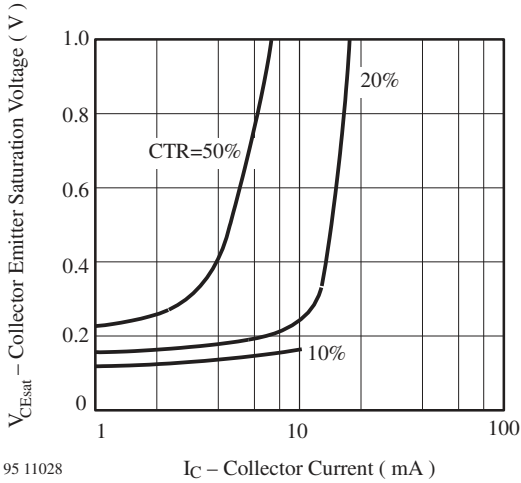
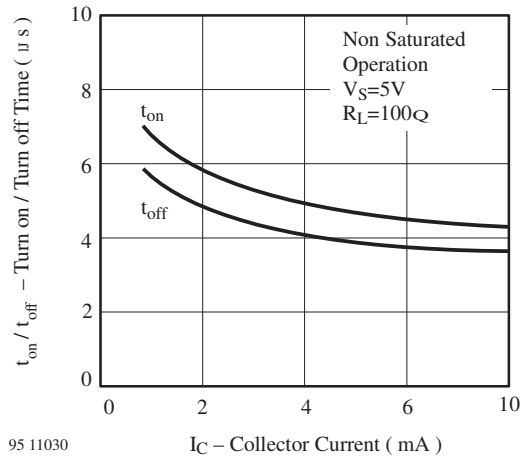

Figure 9. Collector Current vs. Collector Emitter Voltage



95 11028 I_C – Collector Current (mA)
 Figure 10. Collector Emitter Saturation Voltage vs. Collector Current



95 11030 I_C – Collector Current (mA)
 Figure 12. Turn on / off Time vs. Collector Current

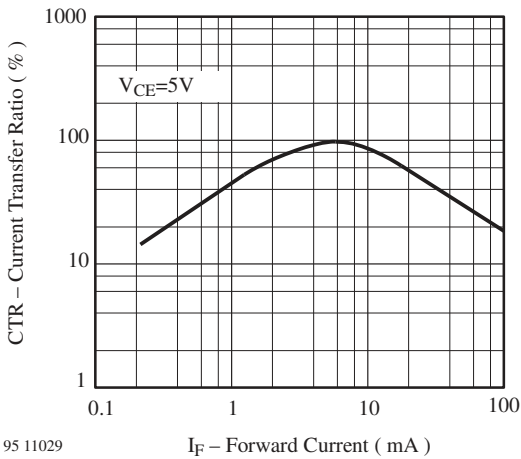

95 11029 I_F – Forward Current (mA)
 Figure 11. Current Transfer Ratio vs. Forward Current

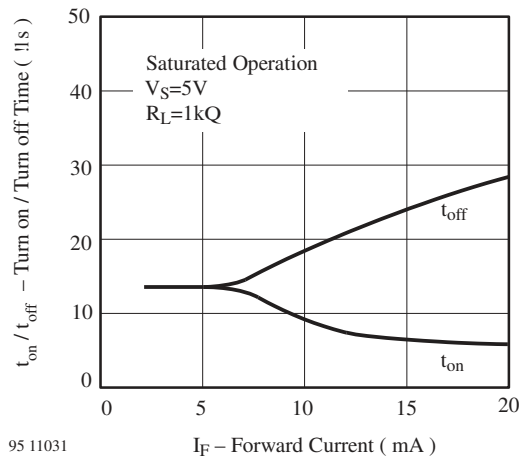

95 11031 I_F – Forward Current (mA)
 Figure 13. Turn on / off Time vs. Forward Current

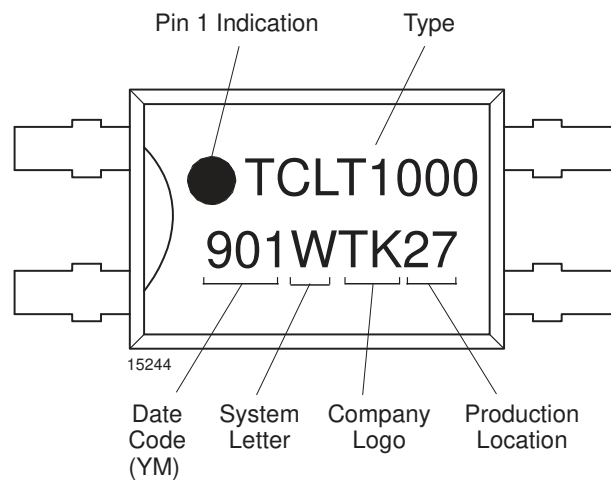
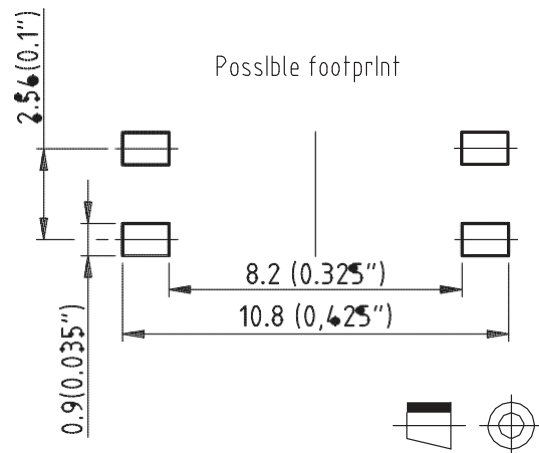
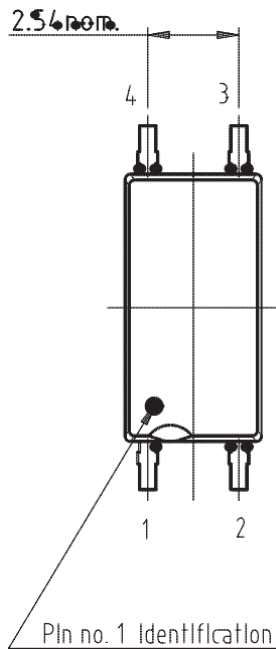
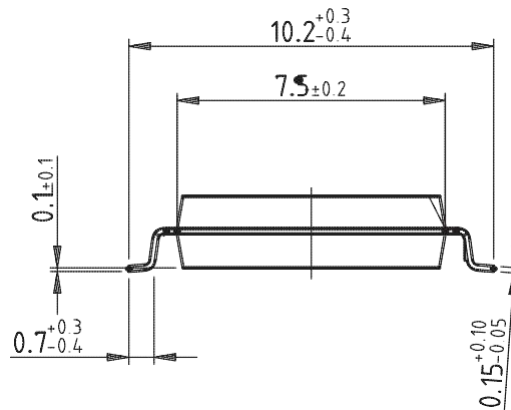
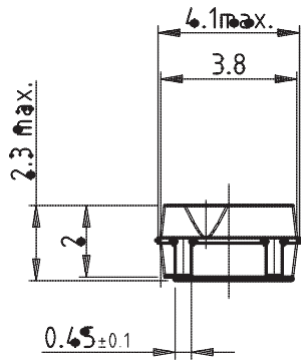

Figure 14. Marking example

Dimensions of TCLT10.. in mm



Technical drawings according to DIN specifications

Drawing-No.: 6.544-5331.01-4

Issue: 1; 04.04.00

15243

TCLT10.. Series

Vishay Telefunken



Dimensions of Reel in mm

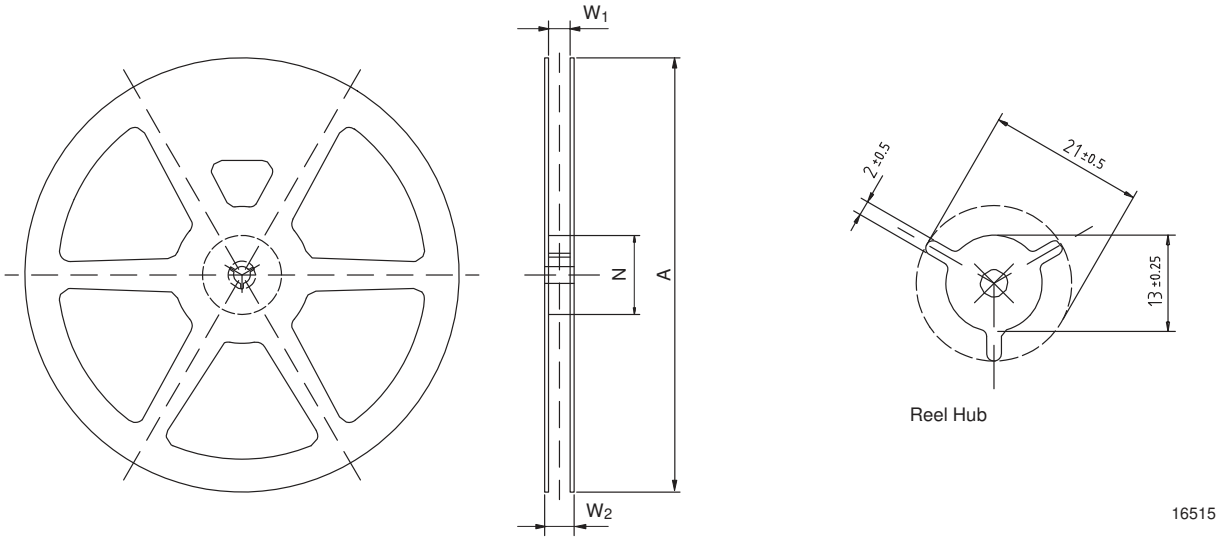

16515

Version	Tape Width	A	N	W_1	$W_{2 \max}$
G	16	330 ± 1	100 ± 1.5	$16.4 + 2$	22.4

Dimensions of Leader and Trailer in mm

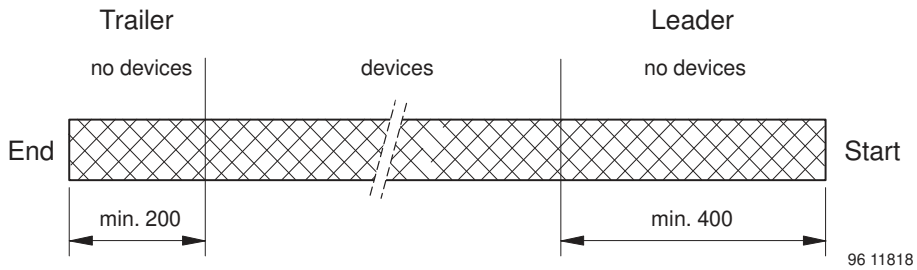

96 11818

Dimensions of Tape in mm

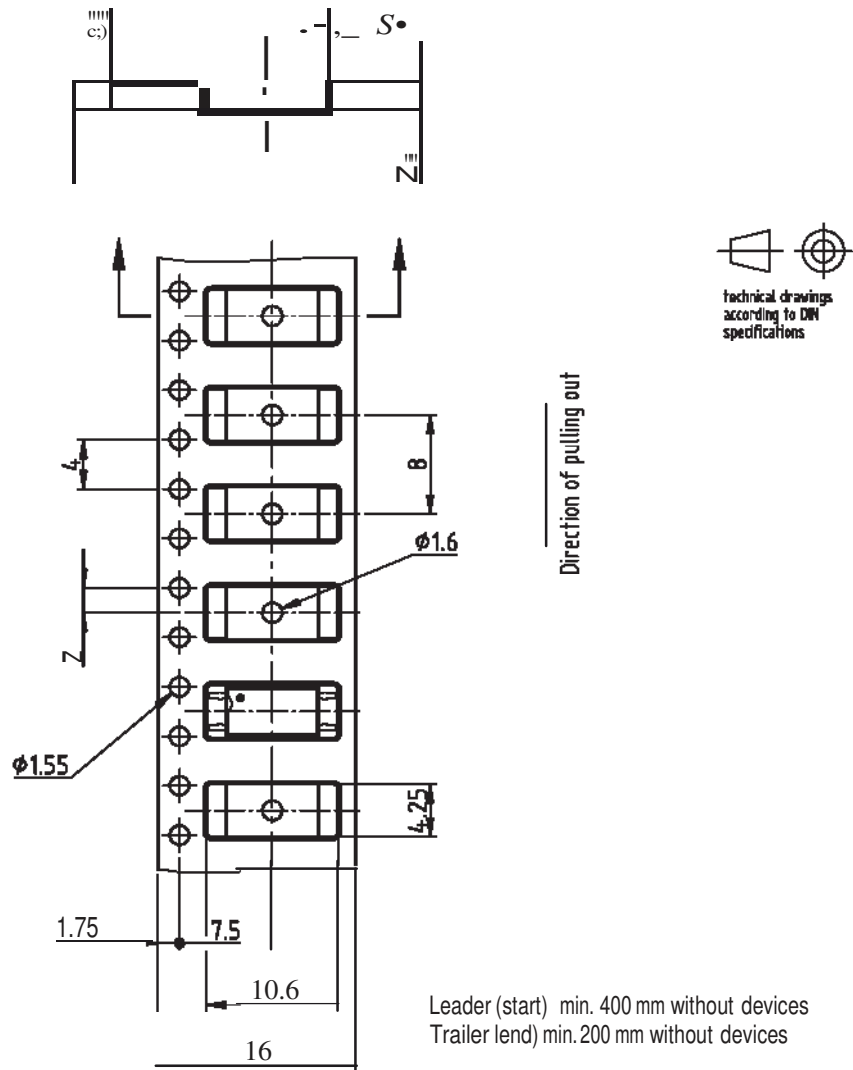

Issue:1; 22.11.00

Drawing refers to following types: TCLT 1...

16516

Ozone Depleting Substances Policy Statement

It is the policy of **Vishay Semiconductor GmbH** to

1. Meet all present and future national and international statutory requirements.
2. Regularly and continuously improve the performance of our products, processes, distribution and operating systems with respect to their impact on the health and safety of our employees and the public, as well as their impact on the environment.

It is particular concern to control or eliminate releases of those substances into the atmosphere which are known as ozone depleting substances (ODSs).

The Montreal Protocol (1987) and its London Amendments (1990) intend to severely restrict the use of ODSs and forbid their use within the next ten years. Various national and international initiatives are pressing for an earlier ban on these substances.

Vishay Semiconductor GmbH has been able to use its policy of continuous improvements to eliminate the use of ODSs listed in the following documents.

1. Annex A, B and list of transitional substances of the Montreal Protocol and the London Amendments respectively
2. Class I and II ozone depleting substances in the Clean Air Act Amendments of 1990 by the Environmental Protection Agency (EPA) in the USA
3. Council Decision 88/540/EEC and 91/690/EEC Annex A, B and C (transitional substances) respectively.

Vishay Semiconductor GmbH can certify that our semiconductors are not manufactured with ozone depleting substances and do not contain such substances.

We reserve the right to make changes to improve technical design and may do so without further notice.

Parameters can vary in different applications. All operating parameters must be validated for each customer application by the customer. Should the buyer use Vishay Telefunken products for any unintended or unauthorized application, the buyer shall indemnify Vishay Telefunken against all claims, costs, damages, and expenses, arising out of, directly or indirectly, any claim of personal damage, injury or death associated with such unintended or unauthorized use.

Vishay Semiconductor GmbH, P.O.B. 3535, D-74025 Heilbronn, Germany
Telephone: 49 (0)7131 67 2831, Fax number: 49 (0)7131 67 2423