

TPS25740B USB Type-C™ and USB PD Source Controller

1 Features

- USB PD 2.0 Certified (TID# 1030004) and USB PD 3.0 Compliant Provider
- Pin-Selectable Voltage Advertisement
 - 5 V, 9 V, 12 V, and 15 V
 - 5 V, 9 V, 15 V, and 20 V
- Pin-Selectable Peak Power Settings
 - 8 Options 18 W – 100 W
- High Voltage and Safety Integration
 - Overvoltage, Overcurrent, Overtemperature Protection and V_{BUS} Discharge
 - IEC 61000-4-2 Protection on CC1 and CC2
 - Input Pin for Fast Shutdown Under Fault
 - Control of External N-ch MOSFET
 - 3-Pin External Power Supply Control
 - Wide VIN Supply (4.65 V – 25 V)
- Below 10 μ A Quiescent Current When Unattached
- Port Attachment Indicator
- Self-Directed Port Power Management for Dual-Port Applications

2 Applications

- USB-PD Adaptor (data-less)
- Dedicated Charging Port (data-less)
- Power Hub (data-less)
- Power Bank
- Cigarette Lighter Adaptor (CLA)

3 Description

The TPS25740B, a fully compliant and USB Power Delivery (PD) 2.0 certified solution, implements a power source for USB Type-C™ PD. It is easy to use and minimizes time to market because there is no firmware or external microcontroller required, just connect it to the board. The device offers four voltages with a maximum voltage and power up to 20 V at 100 W. The TPS25740B automatically handles all USB PD negotiations, handshakes using the CC pins, and selects the voltage from the power supply using the CTLx pins. The PCTRL pin allows for dynamically reducing the amount of power advertised to enable port power management. The TPS25740B integrates functions such as OVP, OCP, ESD, UVLO, OTSD, and VBUS discharge to help save solution size and cost while enabling a safe and robust design. The TPS25740B controls an N-ch MOSFET for the VBUS switch, saving system cost versus solutions that require a P-ch MOSFET. The ultra-low standby power of the TPS25740B makes it easier to pass energy efficiency standards and extends battery life in mobile applications.

The TPS25740B typically draws 8.5 μ A (or 5.8 μ A if $V_{DD} = 3.3$ V) when no device is attached. Additional system power saving is achievable by using the Port Attachment Indicator (DVDD) output to disable the power source when no device is attached.

Protection features include overvoltage protection, overcurrent protection, over-temperature protection, IEC for CC pins, and system override to disable the gate driver (\overline{GD}).

Device Information⁽¹⁾

PART NUMBER	PACKAGE	BODY SIZE (NOM)
TPS25740B	VQFN (24)	4.00 mm x 4.00 mm

(1) For all available packages, see the orderable addendum at the end of the data sheet.

Simplified Schematic

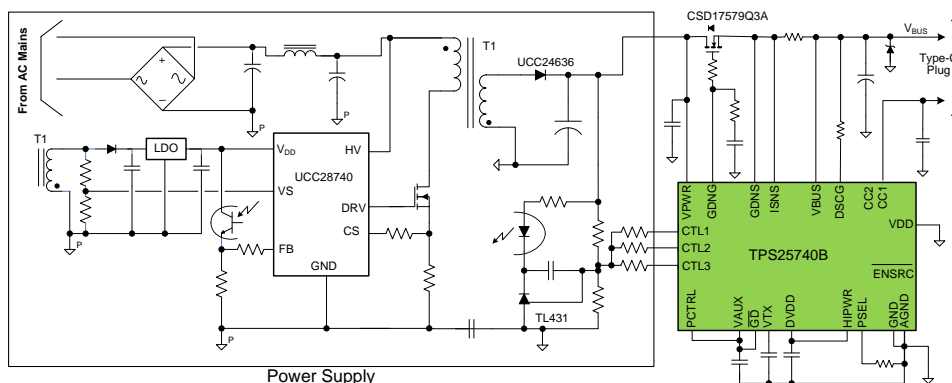

Copyright © 2016, Texas Instruments Incorporated



Table of Contents

1 Features	1	9 Application and Implementation	36
2 Applications	1	9.1 Application Information.....	36
3 Description	1	9.2 Typical Applications	45
4 Revision History	2	9.3 System Examples	52
5 Device Comparison Table	3	10 Power Supply Recommendations	55
6 Pin Configuration and Functions	3	10.1 VDD.....	55
7 Specifications	5	10.2 VPWR	55
7.1 Absolute Maximum Ratings	5	11 Layout	56
7.2 ESD Ratings	5	11.1 Port Current Kelvin Sensing.....	56
7.3 Recommended Operating Conditions.....	6	11.2 Layout Guidelines	56
7.4 Thermal Information	6	11.3 Layout Example	57
7.5 Electrical Characteristics.....	7	12 Device and Documentation Support	58
7.6 Timing Requirements	10	12.1 Documentation Support	58
7.7 Switching Characteristics	11	12.2 Receiving Notification of Documentation Updates	58
7.8 Typical Characteristics	16	12.3 Community Resources.....	58
8 Detailed Description	18	12.4 Trademarks	58
8.1 Overview	18	12.5 Electrostatic Discharge Caution.....	58
8.2 Functional Block Diagram	20	12.6 Glossary	58
8.3 Feature Description.....	20	13 Mechanical, Packaging, and Orderable	
8.4 Device Functional Modes.....	35	Information	58

4 Revision History

NOTE: Page numbers for previous revisions may differ from page numbers in the current version.

Changes from Revision B (November 2017) to Revision C	Page
• Changed t_{CC} to 1 ms.....	10

Changes from Revision A (September 2017) to Revision B	Page
• Changed <i>Description</i> section.....	1

Changes from Original (June 2017) to Revision A	Page
• Changed from Advance Information to Production Data	1

5 Device Comparison Table

DEVICE	COMPLIANT USB PD POWER (PDP) OPTIONS	PIN 8	PIN 11	VOLTAGES OFFERED			
				OPTION 1	OPTION 2	OPTION 3	OPTION 4
TPS25740	15 W	$\overline{\text{EN12V}}$	$\overline{\text{UFP}}$	5 V	5 V, 12 V	5 V, 20 V	5 V, 12 V, 20 V
TPS25740A	15 to 45 W	$\overline{\text{EN9V}}$	$\overline{\text{UFP}}$	5 V	5 V, 9 V	5 V, 15 V	5 V, 9 V, 15 V
TPS25740B	15 to 93 W ⁽¹⁾	CTL3	$\overline{\text{ENSRC}}$	5 V, 9 V, 12 V, 15 V	5 V, 9 V, 15 V, 20 V	N/A	N/A

(1) Up to 93 W PDP with a captive cable, and up to 60 W PDP with receptacle.

6 Pin Configuration and Functions

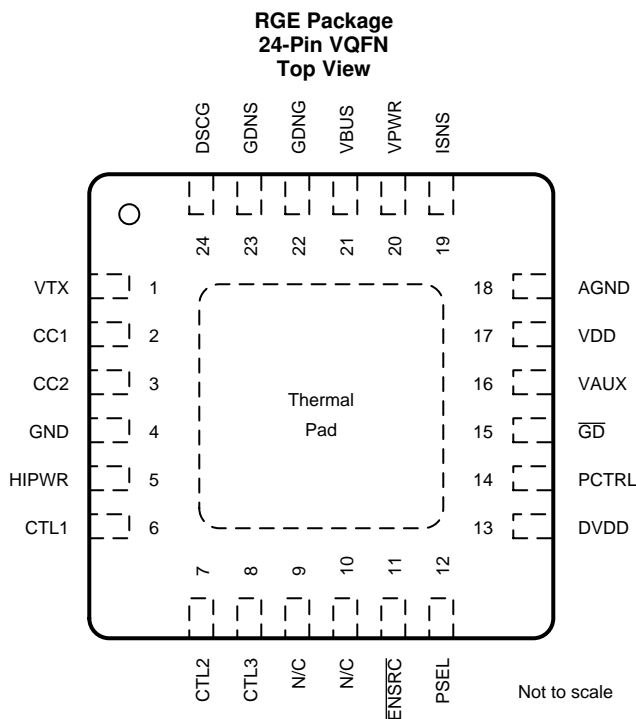

Pin Functions

PIN		I/O	DESCRIPTION
NAME	NO.		
VTX	1	O	Bypass pin for transmit driver supply. Connect this pin to GND via the recommended ceramic capacitor.
CC1	2	I/O	Multifunction configuration channel interface pin to USB Type-C. Functions include connector polarity, end-device connection detect, current capabilities, and PD communication.
CC2	3	I/O	Multifunction configuration channel interface pin to USB Type-C. Functions include connector polarity, end-device connection detect, current capabilities, and PD communication.
GND	4	—	Power ground is associated with power management and gate driver circuits. Connect to AGND and PAD.
HIPWR	5	I	Four-state input pin used to configure the voltages and currents that will be advertised. It may be connected directly to GND or DVDD, or it may be connected to GND or DVDD via a resistance R_{SEL} .
CTL1	6	O	Digital output pin used to control an external voltage regulator.
CTL2	7	O	Digital output pin used to control an external voltage regulator.
CTL3	8	O	Digital output pin used to control an external voltage regulator.

Pin Functions (continued)

PIN		I/O	DESCRIPTION
NAME	NO.		
N/C	9	—	Connect to GND.
N/C	10	—	Connect to GND.
$\overline{\text{ENSRC}}$	11	O	Open drain output pin used to indicate when the VBUS needs to be sourced.
PSEL	12	I	A four-state input used for selecting the maximum power that can be provided. It may be connected directly to GND or DVDD, or it may be connected to GND or DVDD via a resistance $R_{(\text{SEL})}$.
DVDD	13	O	Internally regulated 1.85 V rail for external use up to 35 mA. Connect this pin to GND via the recommended bypass capacitor.
PCTRL	14	I	Input pin used to control the power that will be advertised. It may be pulled high or low dynamically.
$\overline{\text{GD}}$	15	I	Master enable for the GDNG/GDNS gate driver. The system can drive this low to force the power path switch off.
VAUX	16	O	Internally regulated rail for use by the power management circuits. Connect this pin to GND via the recommended bypass capacitor.
VDD	17	I	Optional input supply.
AGND	18	—	Analog ground associated with monitoring and power conditioning circuits. Connect to GND and PAD.
ISNS	19	I	The ISNS input is used to monitor a VBUS-referenced sense resistor for over-current events.
VPWR	20	I	Connect to an external voltage as a source of bias power. If VDD is supplied, this supply is optional while DVDD is low.
VBUS	21	I	The voltage monitor for the VBUS line.
GDNG	22	O	High-voltage open drain gate driver which may be used to drive NMOS power switches. Connect to the gate terminal.
GDNS	23	I	High-voltage open drain gate driver which may be used to drive NMOS power switches. Connect to the source terminal.
DSCG	24	O	Discharge is an open-drain output that discharges the system VBUS line through an external resistor.
Thermal Pad	—	—	Connect thermal pad to GND / AGND plane.

7 Specifications

7.1 Absolute Maximum Ratings

over operating free-air temperature range (unless otherwise noted)⁽¹⁾

		MIN	MAX	UNIT
Pin voltage (sustained)	VDD, CTL1, CTL2, CTL3, $\overline{\text{ENSRC}}$, PCTRL, CC1, CC2	-0.3	6	V
	VTX ⁽²⁾	-0.3	2.1	V
	VAUX ⁽²⁾	-0.3	4.5	V
	$\overline{\text{GD}}$ ⁽³⁾	-0.3	7	V
	HIPWR, PSEL, DVDD ⁽²⁾	-0.3	2.1	V
	GDNG ⁽²⁾	-0.5	40	V
	VBUS, VPWR, ISNS, DSCG, GDNS	-0.5	30	V
Pin voltage (transient for 1ms)	VBUS, VPWR, ISNS, DSCG, GDNS	-1.5	30	V
Pin-to-pin voltage	$V_{(\text{GDNG})} - V_{(\text{GDNS})}$	-0.3	20	V
	AGND to GND	-0.3	0.3	V
	ISNS to VBUS	-0.3	0.3	V
Sinking current (average)	CTL1, CTL2, CTL3, $\overline{\text{ENSRC}}$		8	mA
	$\overline{\text{GD}}$		100	μA
	DSCG		10	mA
Sinking current (transient, 50 ms pulse 0.25% duty cycle)	DSCG		375	mA
Current sourcing	VTX	Internally limited		mA
	CC1, CC2	Internally limited		mA
	VAUX	0	25	μA
Operating junction temperature range, T_J		-40	125	$^{\circ}\text{C}$
Storage temperature, T_{stg}		-65	150	$^{\circ}\text{C}$

- (1) Stresses beyond those listed under *Absolute Maximum Ratings* may cause permanent damage to the device. These are stress ratings only, which do not imply functional operation of the device at these or any other conditions beyond those indicated under *Recommended Operating Conditions*. Exposure to absolute-maximum-rated conditions for extended periods may affect device reliability.
- (2) Do not apply voltage to these pins.
- (3) Voltage allowed to rise above Absolute Maximum provided current is limited.

7.2 ESD Ratings⁽¹⁾

		VALUE	UNIT
$V_{(\text{ESD})}$ Electrostatic discharge	Human-body model (HBM), per ANSI/ESDA/JEDEC JS-001 ⁽²⁾	± 2500	V
	Charged-device model (CDM), per JEDEC specification JESD22-C101 ⁽³⁾	± 1000	
	IEC ⁽⁴⁾ 61000-4-2 contact discharge, CC1, CC2	± 8000	
	IEC ⁽⁴⁾ 61000-4-2 air-gap discharge, CC1, CC2	± 15000	

- (1) This integrated circuit can be damaged by ESD. Texas Instruments recommends that all integrated circuits be handled with appropriate precautions. Failure to observe proper handling and installation procedures can cause damage.
- (2) JEDEC document JEP155 states that 500-V HBM allows safe manufacturing with a standard ESD control process.
- (3) JEDEC document JEP157 states that 250-V CDM allows safe manufacturing with a standard ESD control process.
- (4) These results were passing limits that were obtained on an application-level test board. Individual results may vary based on implementation. Surges per IEC61000-4-2, 1999 applied between CC1/CC2 and ground of TPS25740BEVM-741 and TPS25740BEVM-741

7.3 Recommended Operating Conditions

over operating free-air temperature range (unless otherwise noted)

			MIN	NOM	MAX	UNIT
V _{IN}	Supply voltage	VDD	0		5.5	V
		VPWR	4.65		25	V
V _I	Applied voltage	PCTRL, CC1, CC2, CTL1, CTL2, CTL3	0		5.5	V
		$\overline{\text{GD}}$	0		6.5	V
		DSCG, GDNS, VBUS	0		25	V
		HIPWR, PSEL	0		DVDD	V
V _I	Pin-to-pin voltage	ISNS - VBUS	-0.1		0.1	V
V _{IH}	High level input voltage	$\overline{\text{GD}}$	2		1.6	V
		PCTRL				V
V _{IL}	Low level input voltage	$\overline{\text{GD}}$			1.6	V
		PCTRL				V
I _S	Sinking current	CTL1, CTL2, CTL3, $\overline{\text{ENSRC}}$			1.5	μA
		$\overline{\text{GD}}$			80	μA
		DSCG, transient sinking current 50 ms pulse, 0.25% duty cycle			350	mA
		DSCG, average			5	mA
C _S	Shunt capacitance	CC1, CC2 (C _(RX))	200	560	600	pF
		VBUS (C _(PDIN))			10	μF
		DVDD (C _(DVDD))	0.198	0.22	0.242	μF
		VAUX (C _(VAUX))	0.09	0.1	0.11	μF
		VTX (C _(VTX))	0.09	0.10	0.11	μF
		VDD (C _(VDD))	0.09			μF
R _S	Sense resistance	Configured for 3 A		5	6.4	mΩ
		Configured for 5 A		5	5.8	mΩ
R _(PUD)	Pull up/down resistance	HIPWR, PSEL (direct to GND or direct to DVDD)	0		1	kΩ
		HIPWR, PSEL (R _(SEL))	80	100	120	kΩ
R _(DSCG)	Series resistance	Maximum VBUS voltage of 25 V	80			Ω
		Maximum VBUS voltage of 15 V	43			Ω
		Maximum VBUS voltage of 6 V	20			Ω
T _J	Operating junction temperature				125	°C

7.4 Thermal Information

THERMAL METRIC ⁽¹⁾		TPS25740B	UNIT
		RGE (VQFN)	
		24 PINS	
R _{θJA}	Junction-to-ambient thermal resistance	33	°C/W
R _{θJC(top)}	Junction-to-case (top) thermal resistance	32.6	°C/W
R _{θJB}	Junction-to-board thermal resistance	10	°C/W
ψ _{JT}	Junction-to-top characterization parameter	0.4	°C/W
ψ _{JB}	Junction-to-board characterization parameter	10	°C/W
R _{θJC(bot)}	Junction-to-case (bottom) thermal resistance	2.6	°C/W

(1) For more information about traditional and new thermal metrics, see the [Semiconductor and IC Package Thermal Metrics](#) application report.

7.5 Electrical Characteristics

Unless otherwise stated in a specific test condition the following conditions apply: $-40^{\circ}\text{C} \leq T_J \leq 125^{\circ}\text{C}$; $3 \leq V_{DD} \leq 5.5\text{ V}$, $4.65\text{ V} \leq V_{PWR} \leq 25\text{ V}$; $HIPWR = GND$, $PSEL = GND$, $\overline{GD} = VAUX$, $PCTRL = VAUX$, $AGND = GND$; $VAUX$, VTX , bypassed with $0.1\text{ }\mu\text{F}$, $DVDD$ bypassed with $0.22\text{ }\mu\text{F}$; all other pins open (unless otherwise noted)

PARAMETER		TEST CONDITIONS	MIN	TYP	MAX	UNIT
Voltage Comparator (VBUS)						
$V_{(VBUS_RTH)}$	VBUS threshold (Rising voltage)		4.25	4.45	4.65	V
$V_{(VBUS_FTH)}$	VBUS threshold (Falling voltage)		3.5	3.7	3.9	V
	VBUS threshold (Hysteresis)			0.75		V
Power Supply (VDD, VPWR)						
$V_{(VDD_TH)}$	VDD UVLO threshold	Rising voltage	2.8	2.91	2.97	V
		Falling voltage	2.8	2.86	2.91	
		Hysteresis, comes into effect once the rising threshold is crossed.		0.05		
$V_{(VPWR_RTH)}$	VPWR UVLO threshold rising	Rising voltage	4.2	4.45	4.65	V
$V_{(VPWR_FTH)}$	VPWR UVLO threshold falling	Falling voltage	3.5	3.7	3.9	V
	VPWR UVLO threshold hysteresis	Hysteresis, comes into effect once the rising threshold is crossed.		0.75		V
	Supply current drawn from VDD in sleep mode	VPWR = 0 V, VDD = 5 V, CC1 and CC2 pins are open.		9.2	20	μA
		VPWR = 0 V, VDD = 5 V, CC1 pin open, CC2 pin tied to GND.		94	150	μA
	Supply current drawn from VPWR in sleep mode	VPWR = 5 V, VDD = 0 V, CC1 and CC2 pins are open.		8.5	15	μA
		VPWR = 5 V, VDD = 0 V, CC1 pin open, CC2 pin tied to GND.		90	140	μA
$I_{(SUPP)}$	Operating current while sink attached	PD Sourcing active, VBUS = 5 V, VPWR = 5 V, VDD = 3.3 V	1	1.8	3	mA
Over/Under Voltage Protection (VBUS)						
$V_{(FOVP)}$	Fast OVP threshold, always enabled	5 V PD contract	5.8	6.05	6.3	V
		9 V PD contract	10.1	10.55	11.0	V
		12 V PD contract	13.2	13.75	14.3	V
		15 V PD contract	16.2	16.95	17.7	V
		20 V PD contract	22.1	23.05	24.0	V
$V_{(SOVP)}$	Slow OVP threshold, disabled during voltage transitions. (See Figure 1)	5 V PD contract	5.5	5.65	5.8	V
		9 V PD contract	10	10.2	10.4	V
		12 V PD contract	13.1	13.4	13.7	V
		15 V PD contract	16.3	16.5	17	V
		20 V PD contract	21.5	22.0	22.5	V
$V_{(SUVP)}$	UVP threshold, disabled during voltage transitions (See Figure 1)	5 V PD contract	3.5	3.65	3.8	V
		9 V PD contract	6.8	6.95	7.1	V
		12 V PD contract	9.2	9.45	9.7	V
		15 V PD contract	11.7	11.95	12.2	V
		20 V PD contract	15.7	16.1	16.5	V
VAUX						
$V_{(VAUX)}$	Output voltage	$0 \leq I_{(VAUX)} \leq I_{(VAUXEXT)}$	2.875	3.2	4.1	V
	VAUX current limit		1		5	mA
$I_{(VAUXEXT)}$	External load that may be applied to VAUX.				25	μA
DVDD						
$V_{(DVDD)}$	Output voltage	$0\text{ mA} \leq I_{(DVDD)} \leq 35\text{ mA}$, CC1 or CC2 pulled to ground via $5.1\text{ k}\Omega$, or both CC1 and CC2 pulled to ground via $1\text{ k}\Omega$	1.75	1.85	1.95	V
	Load regulation	Overshoot from $V_{(DVDD)}$, 10-mA minimum, $0.198\text{-}\mu\text{F}$ bypass capacitor	1.7		2	V
	Current limit	DVDD tied to GND	40		150	mA

Electrical Characteristics (continued)

Unless otherwise stated in a specific test condition the following conditions apply: $-40^{\circ}\text{C} \leq T_J \leq 125^{\circ}\text{C}$; $3 \leq V_{DD} \leq 5.5 \text{ V}$, $4.65 \text{ V} \leq V_{PWR} \leq 25 \text{ V}$; $\text{HIPWR} = \text{GND}$, $\text{PSEL} = \text{GND}$, $\overline{\text{GD}} = \text{VAUX}$, $\text{PCTRL} = \text{VAUX}$, $\text{AGND} = \text{GND}$; VAUX , VTX , bypassed with $0.1 \mu\text{F}$, DVDD bypassed with $0.22 \mu\text{F}$; all other pins open (unless otherwise noted)

PARAMETER		TEST CONDITIONS	MIN	TYP	MAX	UNIT
VTX						
	Output voltage	Not transmitting or receiving, 0 to 2 mA external load	1.050	1.125	1.200	V
	Current limit	VTX tied to GND	2.5		10	mA
Gate Driver Disable ($\overline{\text{GD}}$)						
$V_{(\text{GD_TH})}$	Input enable threshold voltage	Rising voltage	1.64	1.725	1.81	V
		Hysteresis		0.15		V
$V_{(\text{GDC})}$	Internal clamp voltage	$I_{(\overline{\text{GD}})} = 80 \mu\text{A}$	6.5	7	8.5	V
$R_{(\text{GD})}$	Internal pulldown resistance	From 0 V to 6 V	3	6	9.5	M Ω
Discharge (DSCG) ⁽¹⁾⁽²⁾						
$V_{(\text{DSCGT})}$	ON state (linear)	$I_{(\text{DSCG})} = 100 \text{ mA}$	0.15	0.42	1	V
$I_{(\text{DSCGT})}$	ON state (saturation)	$V_{(\text{DSCG})} = 4 \text{ V}$, pulsed mode operation	220	553	1300	mA
$R_{(\text{DSCGB})}$	Discharge bleeder	While CC1 is pulled down by 5.1 k Ω and CC2 is open, $V_{(\text{DSCG})} = 25 \text{ V}$	6.6	8.2	10	k Ω
	Leakage current	$0 \text{ V} \leq V_{(\text{DSCG})} \leq 25 \text{ V}$			2	μA
N-ch MOSFET Gate Driver (GDNG, GDNS)						
$I_{(\text{GDNON})}$	Sourcing current	$0 \text{ V} \leq V_{(\text{GDNS})} \leq 25 \text{ V}$, $0 \text{ V} \leq V_{(\text{GDNG})} - V_{(\text{GDNS})} \leq 6 \text{ V}$	13.2	20	30	μA
$V_{(\text{GDNON})}$	Sourcing voltage while enabled ($V_{(\text{GDNG})} - V_{(\text{GDNS})}$)	$0 \text{ V} \leq V_{(\text{GDNS})} \leq 25 \text{ V}$, $I_{(\text{GDNON})} \leq 4 \mu\text{A}$, $V_{DD} = 0 \text{ V}$	8.5		12	V
$R_{(\text{GDNGOFF})}$	Sinking strength while disabled	$V_{(\text{GDNG})} - V_{(\text{GDNS})} = 0.5 \text{ V}$, $0 \leq V_{(\text{GDNS})} \leq 25 \text{ V}$		150	300	Ω
	Sinking strength UVLO (safety)	$V_{DD} = 1.4 \text{ V}$, $V_{(\text{GDNG})} = 1 \text{ V}$, $V_{(\text{GDNS})} = 0 \text{ V}$, $V_{PWR} = 0 \text{ V}$		145		μA
		$V_{PWR} = 1.4 \text{ V}$, $V_{(\text{GDNG})} = 1 \text{ V}$, $V_{(\text{GDNS})} = 0 \text{ V}$, $V_{DD} = 0 \text{ V}$			145	μA
	Off-state leakage	$V_{(\text{GDNS})} = 25 \text{ V}$, $V_{(\text{GDNG})}$ open			7	μA
Power Control Input (PCTRL)						
$V_{(\text{PCTRL_TH})}$	Threshold voltage ⁽³⁾	Voltage rising	1.65	1.75	1.85	V
		Hysteresis		100		mV
	Input resistance	$0 \text{ V} \leq V_{(\text{PCTRL})} \leq V_{(\text{VAUX})}$	1.5	2.9	6	M Ω
Voltage Select (HIPWR), Power Select (PSEL)⁽⁴⁾						
	Leakage current	$0 \text{ V} \leq V_{(\text{HIPWR})} \leq V_{(\text{DVDD})}$, $0 \text{ V} \leq V_{(\text{PSEL})} \leq V_{(\text{DVDD})}$	-1		1	μA
Port Status and Voltage Control (CTL1, CTL2, CTL3, ENSRC)⁽⁵⁾						
V_{OL}	Output low voltage	$I_{OL} = 4 \text{ mA}$ sinking			0.4	V
	Leakage current ⁽⁶⁾	In Hi-Z state, $0 \leq V_{(\text{CTLx})} \leq 5.5 \text{ V}$ or $0 \leq V_{\text{ENSRC}} \leq 5.5 \text{ V}$	-0.5		0.5	μA
Transmitter Specifications (CC1, CC2)						
R_{TX}	Output resistance (zDriver from USB PD in Documentation Support)	During transmission	33	45	75	Ω
$V_{(\text{TXHI})}$	Transmit high voltage	External Loading per Figure 27	1.05	1.125	1.2	V
$V_{(\text{TXLO})}$	Transmit low voltage	External Loading per Figure 27	-75		75	mV
Receiver Specifications (CC1, CC2)						
$V_{(\text{RXHI})}$	Receive threshold (rising)		800	840	885	mV
$V_{(\text{RXLO})}$	Receive threshold (falling)		485	525	570	mV
	Receive threshold (Hysteresis)			315		mV

(1) If T_{J1} is perceived to have been exceeded an OTSD occurs and the discharge FET is disabled.

(2) The discharge pull-down is not active in the sleep mode.

(3) When voltage on the PCTRL pin is less than $V_{(\text{PCTRL_TH})}$, the amount of power advertised is reduced by half.

(4) Leaving HIPWR or PSEL open is an undetermined state and leads to unpredictable behavior.

(5) These pins are high-z during a UVLO, reset, or in Sleep condition.

(6) The pins were designed for less leakage, but testing only verifies that the leakage does not exceed $0.5 \mu\text{A}$.

Electrical Characteristics (continued)

Unless otherwise stated in a specific test condition the following conditions apply: $-40^{\circ}\text{C} \leq T_J \leq 125^{\circ}\text{C}$; $3 \leq V_{DD} \leq 5.5 \text{ V}$, $4.65 \text{ V} \leq V_{PWR} \leq 25 \text{ V}$; $\text{HIPWR} = \text{GND}$, $\text{PSEL} = \text{GND}$, $\overline{\text{GD}} = \text{VAUX}$, $\text{PCTRL} = \text{VAUX}$, $\text{AGND} = \text{GND}$; VAUX , VTX , bypassed with $0.1 \mu\text{F}$, DVDD bypassed with $0.22 \mu\text{F}$; all other pins open (unless otherwise noted)

PARAMETER		TEST CONDITIONS	MIN	TYP	MAX	UNIT
$V_{(\text{INT})}$	Amplitude of interference that can be tolerated	Interference is 600 kHz square wave, rising 0 to 100 mV.			100	mV
		Interference is 1 MHz sine wave			1	V_{PP}
DFP Specifications (CC1, CC2)						
$V_{(\text{DSTD})}$		In standard Rp mode ⁽⁷⁾ , voltage rising	1.52	1.585	1.65	V
		Hysteresis		0.02		V
$V_{(\text{D1.5})}$	Detach threshold when cable is detached.	In 1.5 A Rp mode ⁽⁸⁾ , voltage rising	1.52	1.585	1.65	V
		Hysteresis		0.02		V
$V_{(\text{D3.0})}$		In 3 A Rp mode ⁽⁹⁾ , voltage rising	2.50	2.625	2.75	V
		Hysteresis		0.05		V
$V_{(\text{OCN})}$	Unloaded output voltage on CC pin	normal mode	2.75		4.35	V
$V_{(\text{OCDS})}$		$V_{PWR} = 0 \text{ V}$ (in UVLO) or in sleep mode	1.8		5.5	V
$I_{(\text{RPSTD})}$	Loaded output current while connected through CCx	In standard Rp mode1, CCy open, $0 \text{ V} \leq V_{CCx} \leq 1.5 \text{ V}$ (vRd)	64	80	96	μA
$I_{(\text{RP1.5})}$		In 1.5 A Rp mode 2, CCy open, $0 \text{ V} \leq V_{CCx} \leq 1.5 \text{ V}$ (vRd)	166	180	194	μA
$I_{(\text{RP3.0})}$		In 3 A Rp mode 3, CCy open, $0 \text{ V} \leq V_{CCx} \leq 1.5 \text{ V}$ (vRd)	304	330	356	μA
$V_{(\text{RDSTD})}$	Ra, Rd detection threshold (falling)	In standard Rp mode1, $0 \text{ V} \leq V_{CCx} \leq 1.5 \text{ V}$ (vRd)	0.15	0.19	0.23	V
		Hysteresis		0.02		V
$V_{(\text{RD1.5})}$		In 1.5 A Rp mode2, CCy open $0 \text{ V} \leq V_{CCx} \leq 1.5 \text{ V}$ (vRd)	0.35	0.39	0.43	V
		Hysteresis		0.02		V
$V_{(\text{RD3.0})}$		In 3 A Rp mode3, CCy open $0 \text{ V} \leq V_{CCx} \leq 1.5 \text{ V}$ (vRd)	0.75	0.79	0.83	V
		Hysteresis		0.02		V
$V_{(\text{WAKE})}$	Wake threshold (rising and falling), exit from sleep mode	$V_{PWR} = 4.65 \text{ V}$, $0 \text{ V} \leq V_{DD} \leq 3 \text{ V}$ ⁽¹⁰⁾	1.6		3.0	V
$I_{(\text{DSDFP})}$	Output current on CCx in sleep mode to detect Ra removal	$\text{CCx} = 0\text{V}$, CCy floating	40	73	105	μA
OverCurrent Protection (ISNS, VBUS)						
$V_{(\text{TRIP})}$	Current trip shunt voltage	Specified as $V_{(\text{ISNS})} - V_{(\text{VBUS})}$. 3.5 V ⁽¹¹⁾ $\leq \text{VBUS} \leq 25 \text{ V}$				
		HIPWR: 5 A not enabled	19.2		22.6	mV
		HIPWR = DVDD (5 A enabled)	29		34	mV
OTSD						
T_{J1}	Die temperature (Analog) ⁽¹²⁾	$T_J \uparrow$	125	135	145	$^{\circ}\text{C}$
		Hysteresis		10		
T_{J2}	Die temperature (Analog) ⁽¹³⁾	$T_J \uparrow$	140	150	163	$^{\circ}\text{C}$
		Hysteresis		10		

(7) Standard Rp mode is active after a USB Type-C sink, debug accessory, or audio accessory is attached until the first USB PD message is transmitted (after GDNG has been enabled).

(8) 1.5 A Rp mode is active after a USB PD message is received.

(9) 3 A Rp mode is active after GDNG has been enabled until a USB PD message is received.

(10) $V_{\text{WAKE}} < V_{\text{OCDS}}$ is always true.

(11) Common mode minimum aligns to VBUS UVLO. VBUS must be above its UVLO for the OCP function to be active.

(12) When T_{J1} trips a hard reset is transmitted and discharge is disabled, but the bleed discharge is not disabled.

(13) T_{J2} trips only when some external heat source drives the temperature up. When it trips the DVDD, and VAUX power outputs are turned off.

7.6 Timing Requirements

Unless otherwise stated in a specific test condition the following conditions apply: $-40^{\circ}\text{C} \leq T_J \leq 125^{\circ}\text{C}$; $3 \leq V_{DD} \leq 5.5 \text{ V}$, $4.65 \text{ V} \leq V_{PWR} \leq 25 \text{ V}$; $\text{HIPWR} = \text{GND}$, $\text{PSEL} = \text{GND}$, $\overline{\text{GD}} = \text{VAUX}$, $\text{PCTRL} = \text{VAUX}$, $\text{AGND} = \text{GND}$; VAUX , VTX , bypassed with $0.1 \mu\text{F}$, DVDD bypassed with $0.22 \mu\text{F}$; all other pins open (unless otherwise noted)

		MIN	NOM	MAX	UNIT	
t_{FOVDPDG}	Deglintch for fast over-voltage protection		5		μs	
t_{OCP}	Deglintch filter for over-current protection			15	μs	
	Time power is applied until CC1 and CC2 pull-ups are applied.	$V_{(\text{VPWR})} > V_{(\text{VPWR_TH})}$ OR $V_{(\text{VDD})} > V_{(\text{VDD_TH})}$		2.5	4	ms
t_{CC}	Falling/Rising voltage deglintch time for detection on CC1 and CC2		1		ms	
Transmitter Specifications (CC1, CC2)						
t_{UI}	Bit unit Interval	3.05	3.3	3.70	μs	
	Rise/fall time, t_{Fall} and t_{Rise} (refer to USB PD in Documentation Support)	External Loading per Figure 27		300	600	ns

7.7 Switching Characteristics

Unless otherwise stated in a specific test condition the following conditions apply: $-40^{\circ}\text{C} \leq T_J \leq 125^{\circ}\text{C}$; $3 \leq V_{DD} \leq 5.5 \text{ V}$, $4.65 \text{ V} \leq V_{PWR} \leq 25 \text{ V}$; $\text{HIPWR} = \text{GND}$, $\text{PSEL} = \text{GND}$, $\overline{\text{GD}} = \text{VAUX}$, $\text{PCTRL} = \text{VAUX}$, $\text{AGND} = \text{GND}$; VAUX , VTX , bypassed with $0.1 \mu\text{F}$, DVDD bypassed with $0.22 \mu\text{F}$; all other pins open (unless otherwise noted)

PARAMETER		TEST CONDITIONS	MIN	TYP	MAX	UNIT
t_{VP}	Delay from enabling external NFET until under-voltage and OCP protection are enabled	$\text{VBUS} = \text{GND}$		190		ms
t_{STL}	Source settling time, time from CTL1, CTL2, or CTL3 being changed until a PS_RDY USB PD message is transmitted to inform the sink is may draw full current. (refer to USB PD in Documentation Support)			260		ms
t_{SR}	Time that GDNG is disabled after a hard reset. This is $t_{\text{SrcRecover}}$. (refer to USB PD in Documentation Support)	$T_J > T_{J1}$		765		ms
t_{HR}	Time after hard reset is transmitted until GDNG is disabled. This is $t_{\text{PSHardReset}}$. (refer to USB PD in Documentation Support)			30		ms
t_{CCDeb}	Time until $\overline{\text{ENSRC}}$ is pulled low after sink attachment, this is the USB Type-C required debounce time for attachment detection called $t_{\text{CCDebounce}}$. (refer to USB Type-C in Documentation Support)			185		ms
t_{ST}	Delay after sink request is accepted until CTL1, CTL2, or CTL3 is changed. This is called $t_{\text{SnkTransition}}$. (refer to USB PD in Documentation Support)			30		ms
t_{FLT}	The time in between hard reset transmissions in the presence of a persistent supply fault.	$\overline{\text{GD}} = \text{GND}$ or $\text{VPWR} = \text{GND}$, sink attached		1395		ms
t_{SH}	The time in between retries (hard reset transmissions) in the presence of a persistent VBUS short.	$\text{VBUS} = \text{GND}$, sink attached		985		ms
t_{ON}	The time from $\overline{\text{ENSRC}}$ being pulled low until a hard reset is transmitted. Designed to be greater than $t_{\text{SrcTurnOn}}$. (refer to USB PD in Documentation Support)	$\overline{\text{GD}} = 0 \text{ V}$ or $\text{VPWR} = 0 \text{ V}$		600		ms
	Retry interval if USB PD sink stops communicating without being removed or if sink does not communicate after a fault condition. Time GDNG remains enabled before a hard reset is transmitted. This is the $t_{\text{NoResponse}}$ time. (refer to USB PD in Documentation Support)	Sink attached		4.8		s
t_{DVDD}	Delay before DVDD is driven high	After sink attached			5	ms
t_{GDoff}	Turnoff delay, time until $V_{(\text{GDNG})}$ is below 10% of its initial value after the GD pin is low	$\overline{\text{VGD}}: 5 \text{ V} \rightarrow 0 \text{ V}$ in $< 0.5 \mu\text{s}$			5	μs
t_{FOVP}	Response time when VBUS exceeds the fast-OVP threshold	$\text{VBUS} \uparrow$ to GDNG OFF ($V_{(\text{GDNG})}$ below 10% its initial value)			30	μs
	OCP large signal response time	5 A enabled, $V_{(\text{ISNS})} - V_{(\text{VBUS})}: 0 \text{ V} \rightarrow 42 \text{ mV}$ measured to GDNG transition start			30	μs
	Time until discharge is stopped after T_{J1} is exceeded.	$0 \text{ V} \leq V_{(\text{DSCG})} \leq 25 \text{ V}$			10	μs
	Digital output fall time	$V_{(\text{PULLUP})} = 1.8 \text{ V}$, $C_L = 10 \text{ pF}$, $R_{(\text{PULLUP})} = 10 \text{ k}\Omega$, $V_{(\text{CTLx})}$ or $V_{(\text{ENSRC})}: 70\% V_{\text{PULLUP}} \rightarrow 30\% V_{\text{PULLUP}}$	20		300	ps

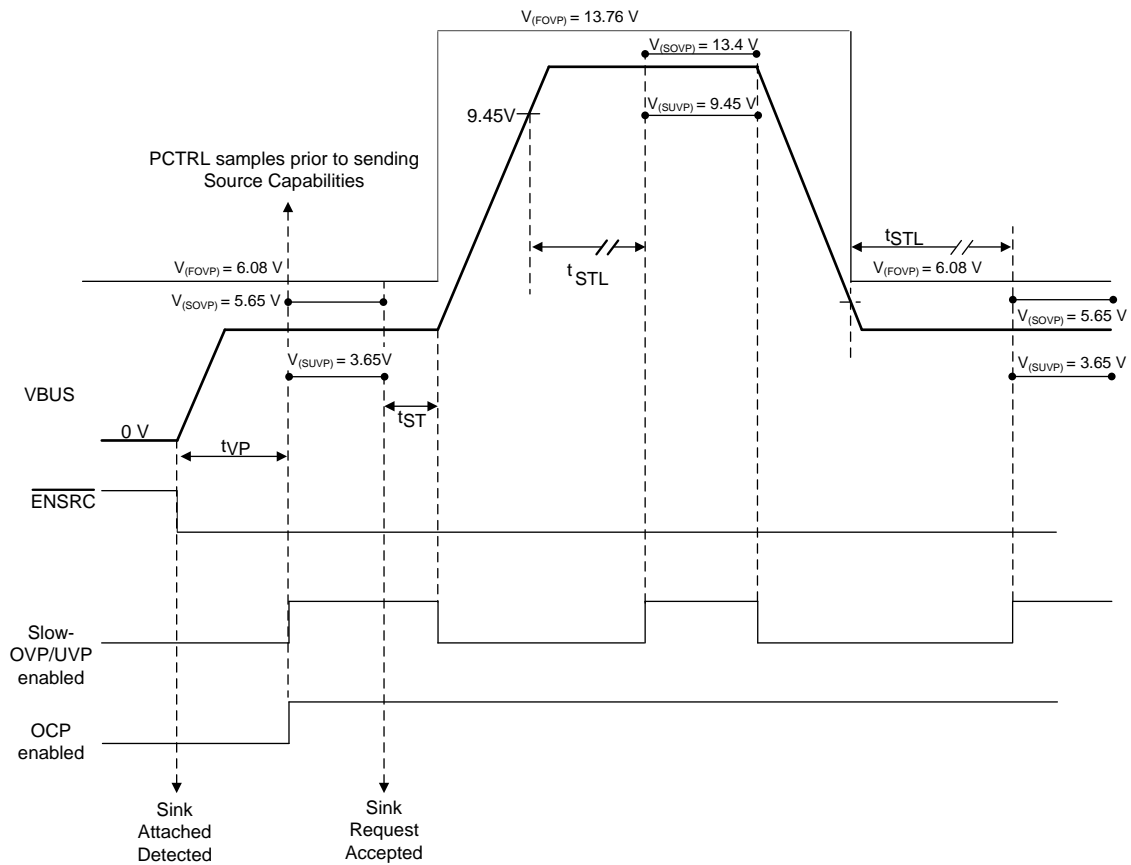

Figure 1. Timing Illustration for t_{VP} , t_{ST} and t_{STL} , After Sink Attachment Negotiation to 12 V Then Back to 5 V. $V_{(SOVP)}$ and $V_{(SUVP)}$ are Disabled Around Voltage Transitions.

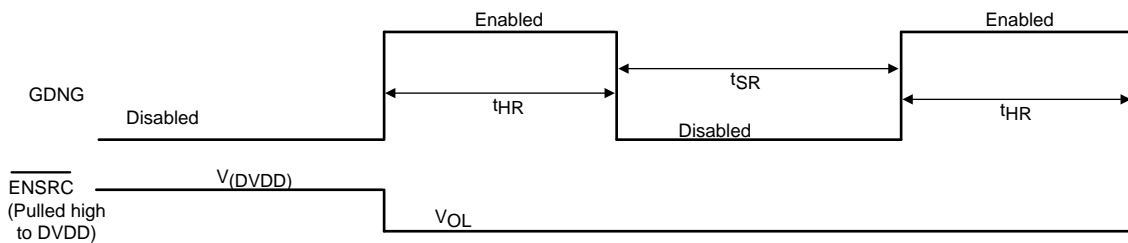

Figure 2. Timing Illustration for t_{HR} and t_{SR} , After Sink Attachment with Persistent $T_J > T_{J1}$

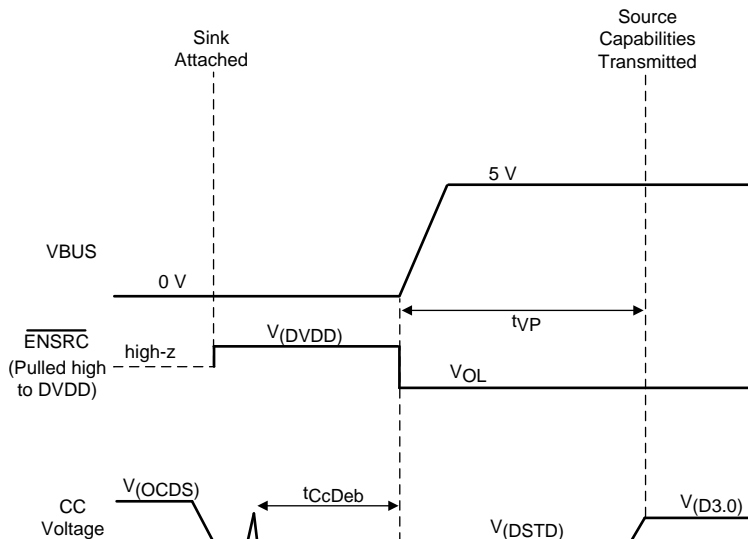

Figure 3. Timing Illustration for t_{CcDeb} and t_{VP} , Under Persistent Fault Condition

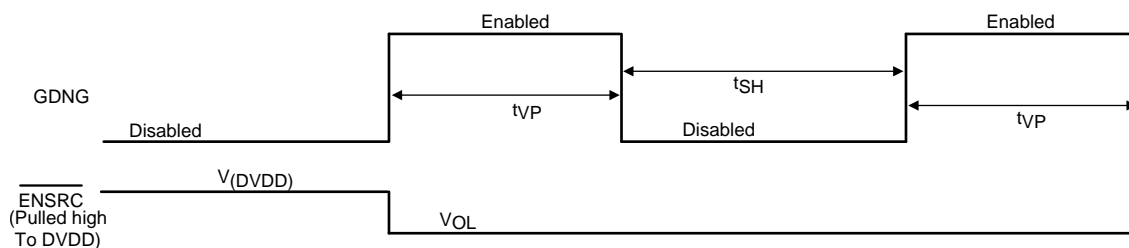

Figure 4. Timing Illustration for t_{SH} and t_{VP} , with VBUS Shorted to Ground

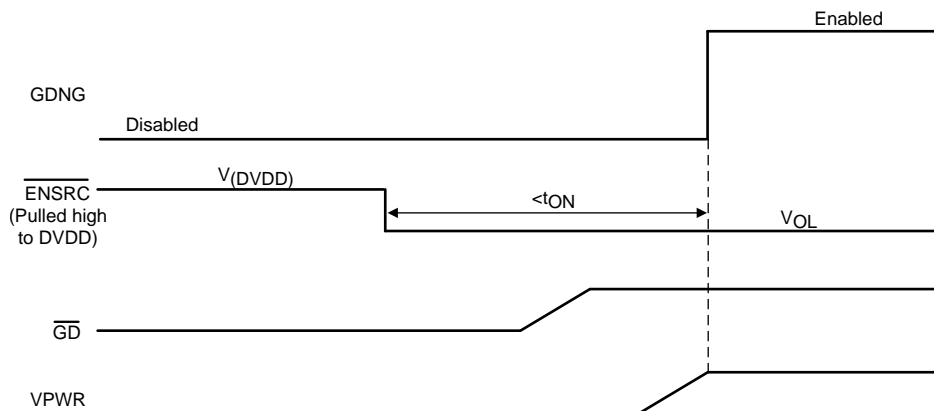

Figure 5. Timing Illustration for t_{ON}

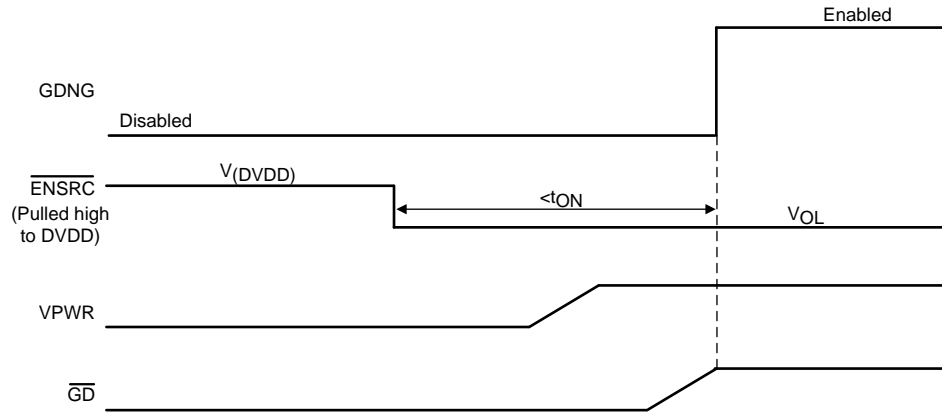

Figure 6. Timing Illustration for t_{ON}

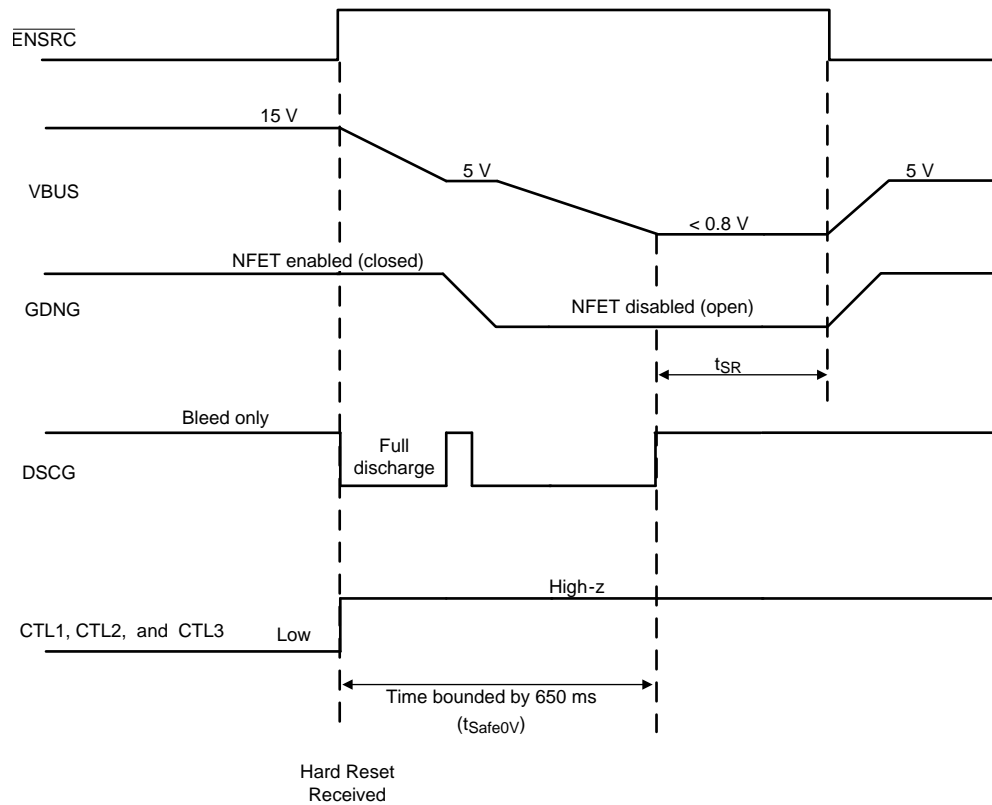

Figure 7. Timing Diagram for \overline{ENSRC} and $GDNG$ After Receiving a Hard Reset

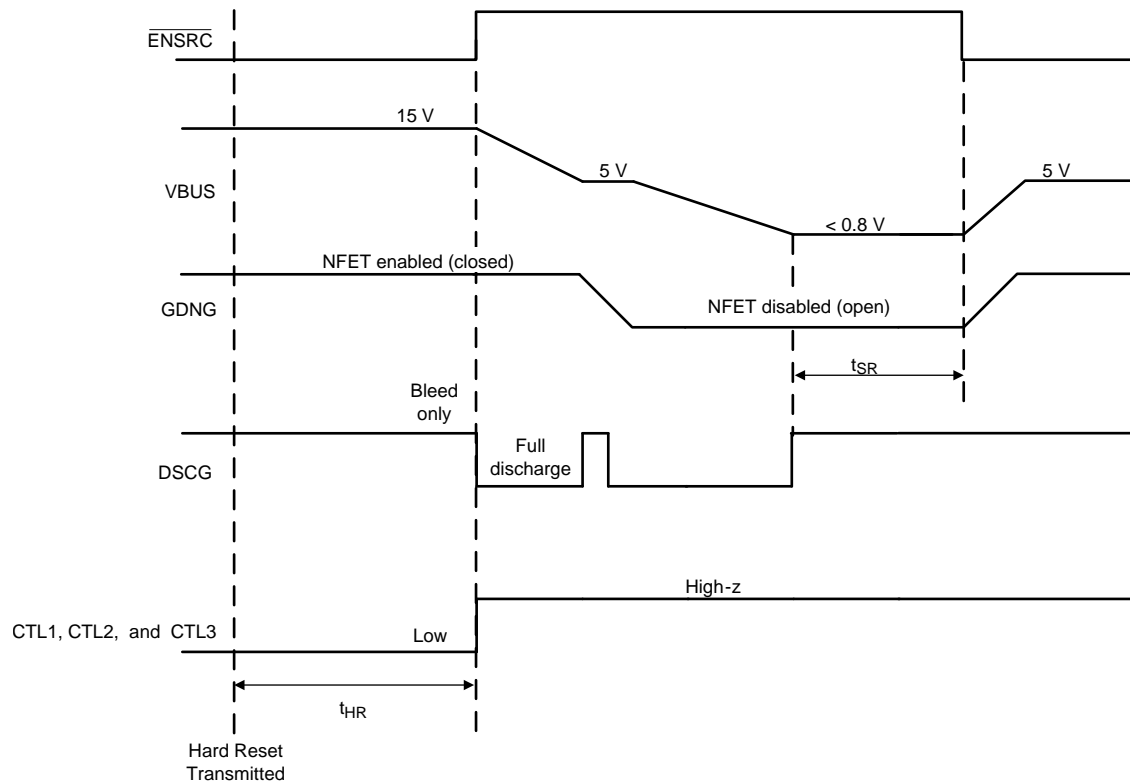
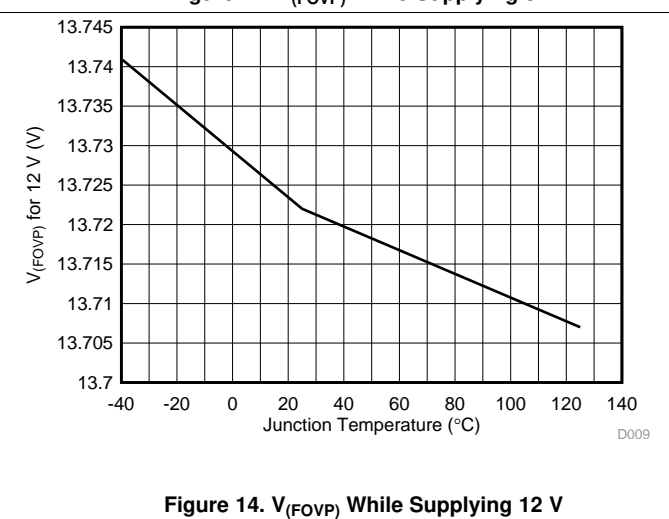
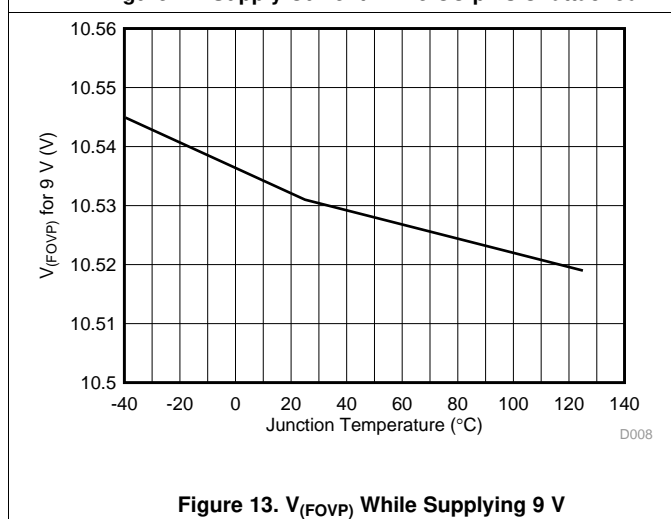
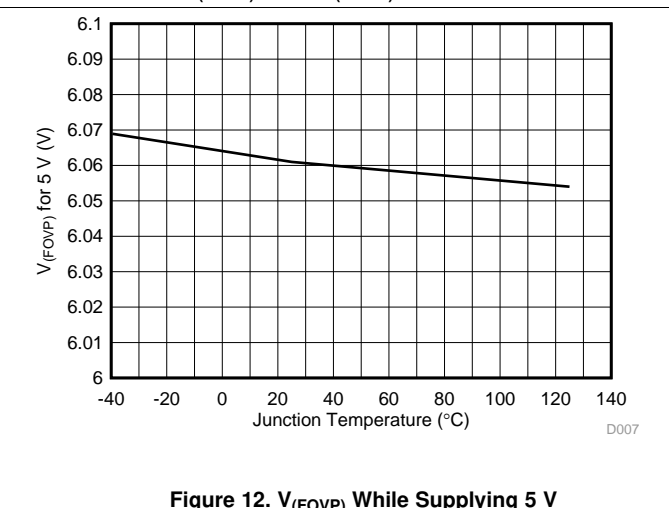
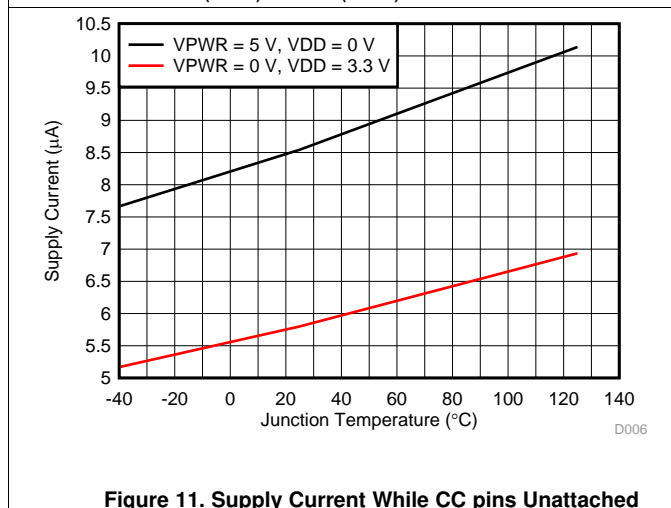
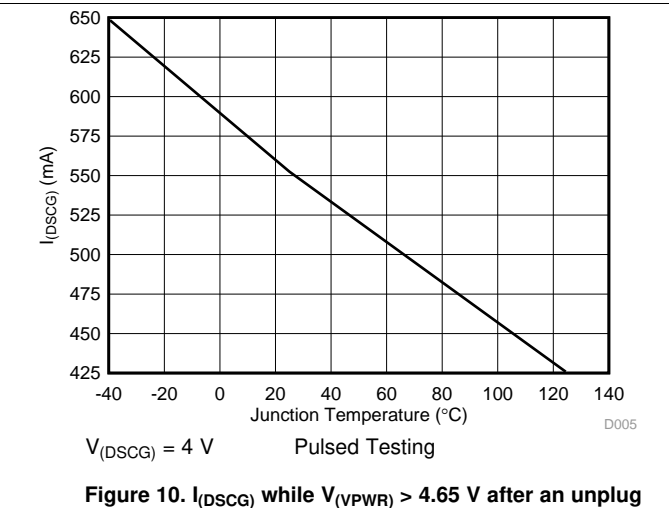
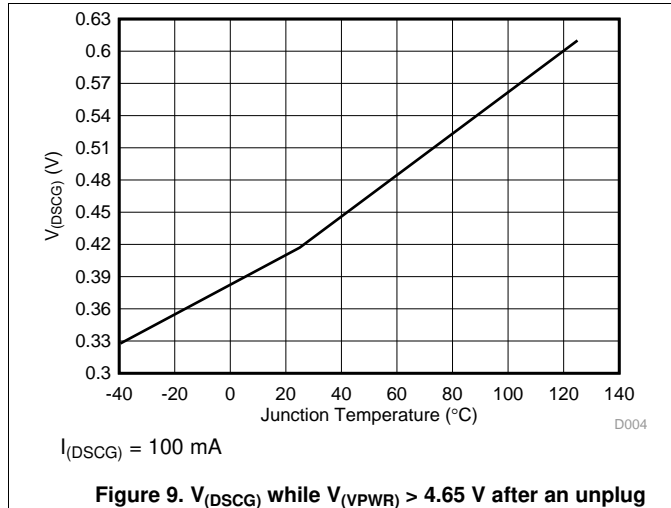

Figure 8. Timing Diagram for $\overline{\text{ENSRC}}$ and GDNG After Transmitting a Hard Reset

7.8 Typical Characteristics



Typical Characteristics (continued)

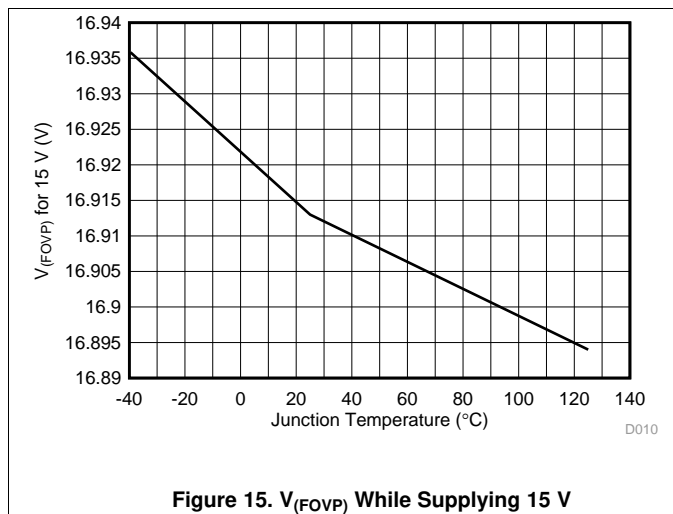

Figure 15. $V_{(FOVP)}$ While Supplying 15 V

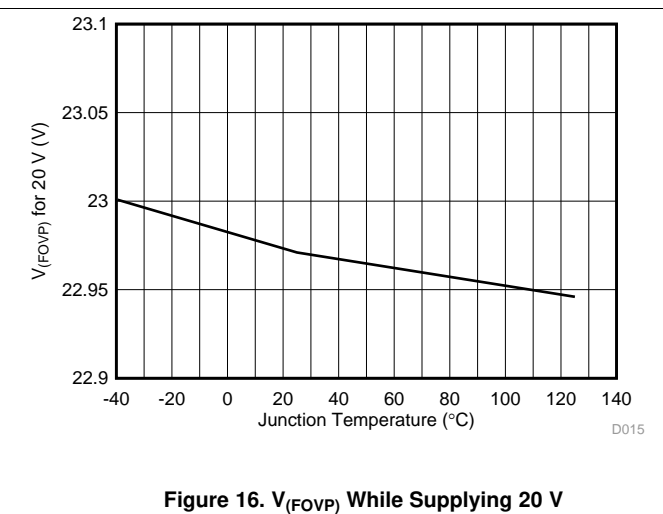

Figure 16. $V_{(FOVP)}$ While Supplying 20 V

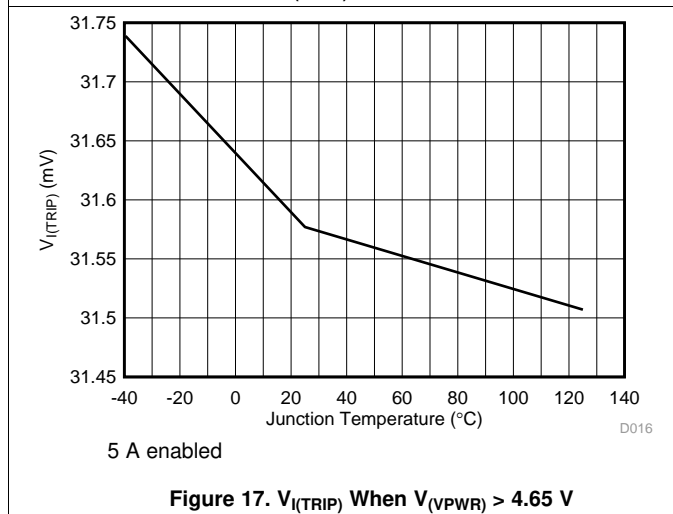

Figure 17. $V_{(I(TRIP))}$ When $V_{(VPWR)} > 4.65$ V

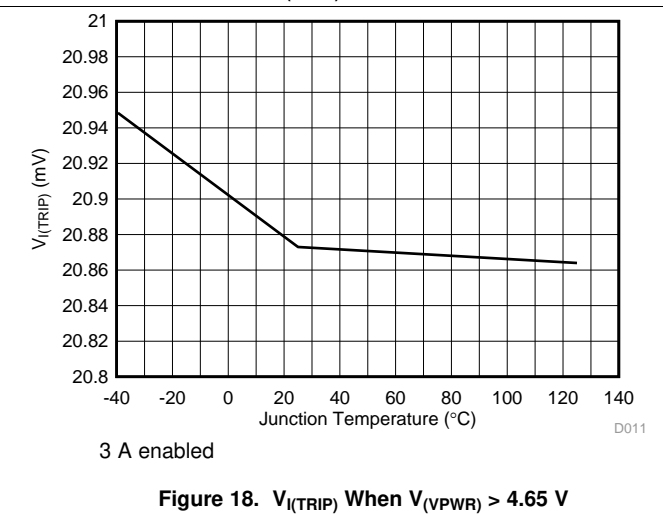

Figure 18. $V_{(I(TRIP))}$ When $V_{(VPWR)} > 4.65$ V

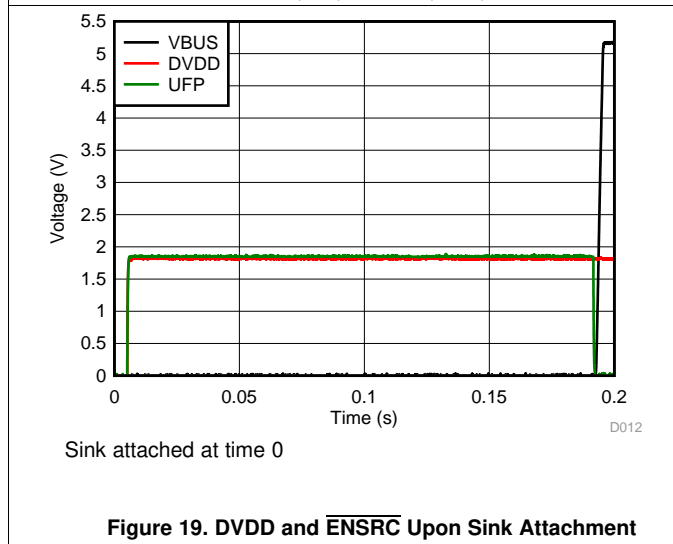

Figure 19. DVDD and \overline{ENSRC} Upon Sink Attachment

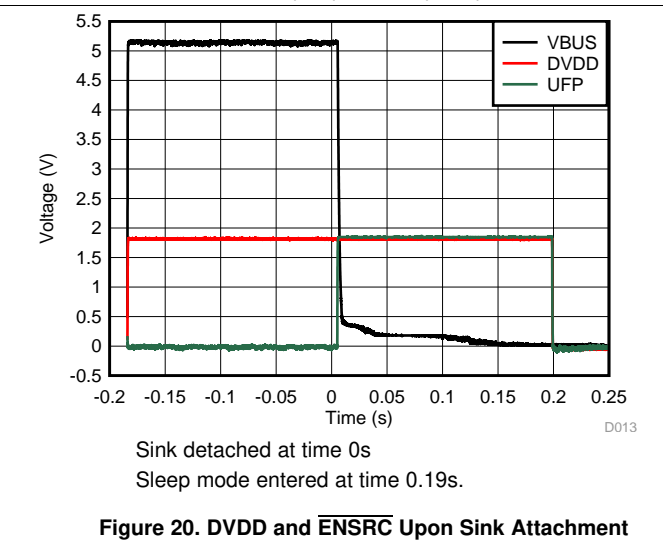

Figure 20. DVDD and \overline{ENSRC} Upon Sink Attachment

8 Detailed Description

8.1 Overview

The TPS25740B and supporting circuits perform the functions required to implement a USB Power Delivery (PD) 2.0 as a provider-only and a USB Type-C revision 1.2 source. It uses its CC pins to detect the attachment of a sinking device or upward facing port (UFP) and to determine which of CC1 or CC2 is connected to the CC wire of the cable. It then communicates over the CC wire in the cable bundle using USB PD to offer a set of voltages and currents. USB PD is a technology that utilizes the ubiquitous USB communications and hardware infrastructure to extend the amount of power available to devices from the 7.5 W range for USB BC1.2 to as high as 100 W in a dock. It is a compatible overlay to USB 2.0 and USB 3.0, coexisting with the existing 5 V powered universe of devices by use of adapter cables. Some basic characteristics of this technology relevant to the device include:

- Increased power achieved by providing higher current and/or higher voltage.
- New 3 A cable and 5 A connector to support greater than the traditional 1.5 A.
 - Cables have controlled voltage drop
- Voltages greater than 5 V are negotiated between PD partners.
 - Standard 5 V is always the default source voltage.
 - Voltage and current provisions are negotiated between PD partners.
- PD partners negotiate over the CC line to avoid conflict with existing signaling (that is, D+, D-)
- Layered communication protocol defined including PHY, Protocol Layer, Policy Engine, and Device Policy Manager all implemented within the device.
- The Type-C connector standard implements pre-powerup signaling to determine:
 - Connector orientation
 - Source 5-V capability
 - Detect through connection of a UFP (upward facing port) to a DFP (downward facing port).
 - Detection of when the connected UFP is disconnected. VBUS is unpowered until a through-connection is present

Figure 21 and Figure 22 show a typical configuration for the device.

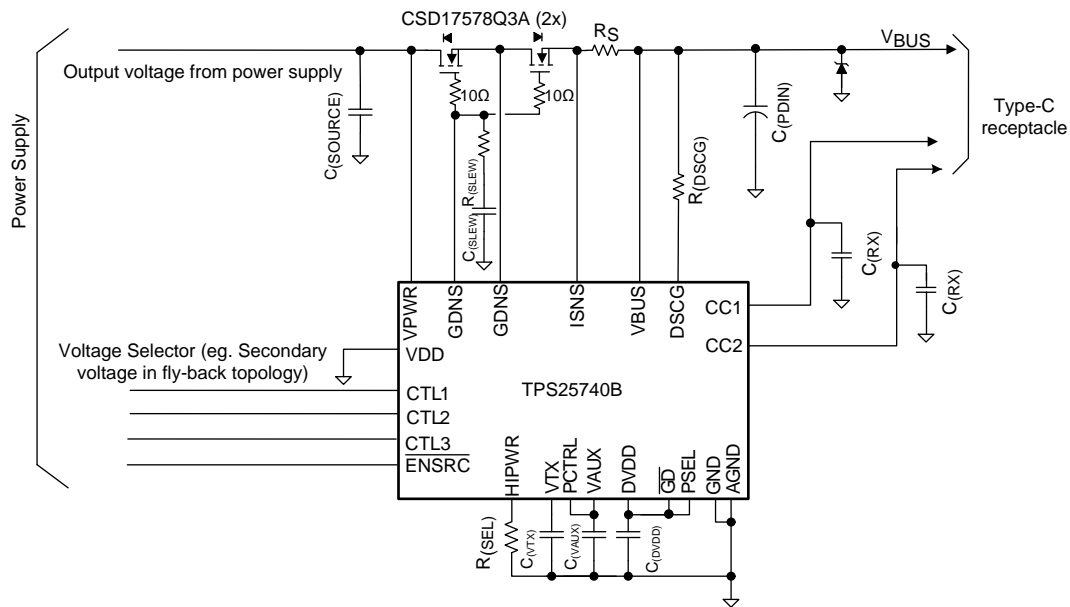

Copyright © 2016, Texas Instruments Incorporated

Figure 21. Schematic 1

Overview (continued)

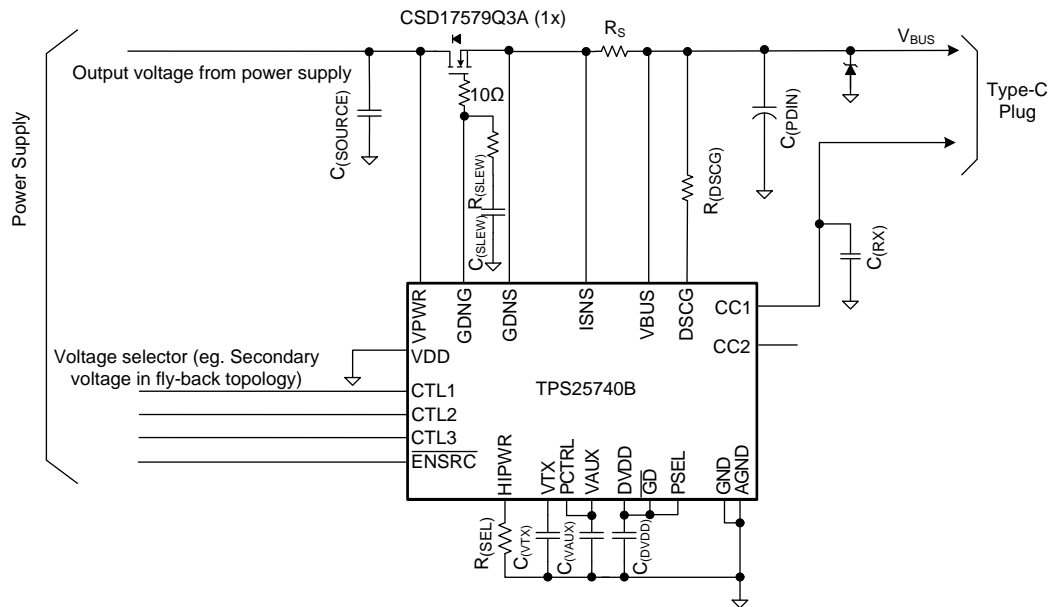

Copyright © 2016, Texas Instruments Incorporated

Figure 22. Schematic 2

8.1.1 VBUS Capacitance

The USB Type-C specification requires that the capacitance on the VBUS pin of an empty receptacle be below 10 μF . This is to protect legacy USB sources that are not designed to handle the larger inrush capacitance and which may be connected via an A-to-C cable. For applications with USB Type-C receptacles and large bulk capacitance, this means back-to-back blocking FETs are required as shown in [Figure 21](#). However, for applications with a USB Type-C plug (that is, a captive cable) this requirement does not apply since an adaptor cable with a USB Type-C receptacle and a Type-A plug is not defined or allowed by the USB I/F. [Figure 22](#) is a schematic for such applications.

8.1.2 USB Data Communications

The USB Power Delivery specification requires that sources such as the device advertise in the source capabilities messages they transmit whether or not they are in a product that supports USB data communications. The device has this bit hard-coded to 0.

8.2 Functional Block Diagram

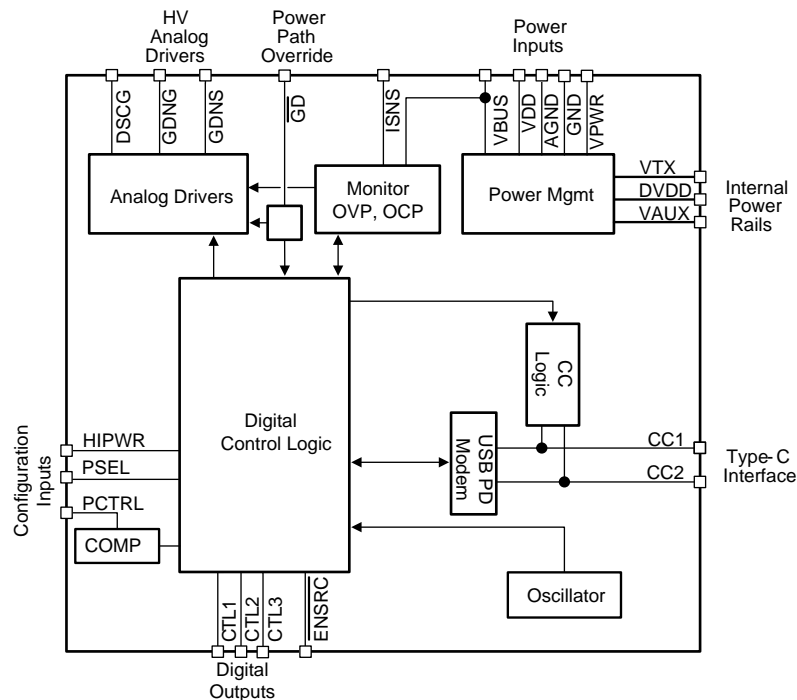

Copyright © 2016, Texas Instruments Incorporated

8.3 Feature Description

This section describes the features associated with each pin for the device.

8.3.1 ENSRC

$\overline{\text{ENSRC}}$ is an open-drain output pin used to indicate whether voltage is being provided to the port. $\overline{\text{ENSRC}}$ goes low when a sink is attached to the port and VBUS is low. A sink attachment is detected when the voltage on one (not both) of the CC pins remains between $V_{(\text{RDSTD})}$ and $V_{(\text{DSTD})}$ for t_{CcDeb} and the voltage on the VBUS pin is below $V_{(\text{VBUS_FTH})}$. After being pulled low, ENSRC remains low until TPS25740B determines that it should remove voltage from the port at which time it goes to high-z. In some applications, the ENSRC pin may be used to disable the power supply instead of using a blocking NFET (See [Using ENSRC to Enable the Power Supply upon Sink Attachment](#)).

8.3.2 USB Type-C CC Logic (CC1, CC2)

The device uses a current source to implement the pull up resistance USB Type-C requires for Sources. While waiting for a valid connection, the device applies a default pullup of $I_{(\text{RPSTD})}$. A sink attachment is detected when the voltage on one (not both) of the CC pins remains between $V_{(\text{RDSTD})}$ and $V_{(\text{DSTD})}$ for t_{CcDeb} and the voltage on the VBUS pin is below $V_{(\text{VBUS_FTH})}$. Then after turning on VBUS and disabling the R_p current source for the CCx pin not connected through the cable, the device applies $I_{(\text{RP3.0})}$ to advertise 3 A to non-PD sinks. Finally, if it is determined that the attached sink is PD-capable, the device applies $I_{(\text{RP1.5})}$. During this sequence if the voltage on the monitored CC pin exceeds the detach threshold then the device removes VBUS and begins watching for a sink attachment again.

The TPS25740B digital logic selects the current source switch as illustrated in [Figure 23](#). The schematic shown is replicated for each CC pin.

Feature Description (continued)

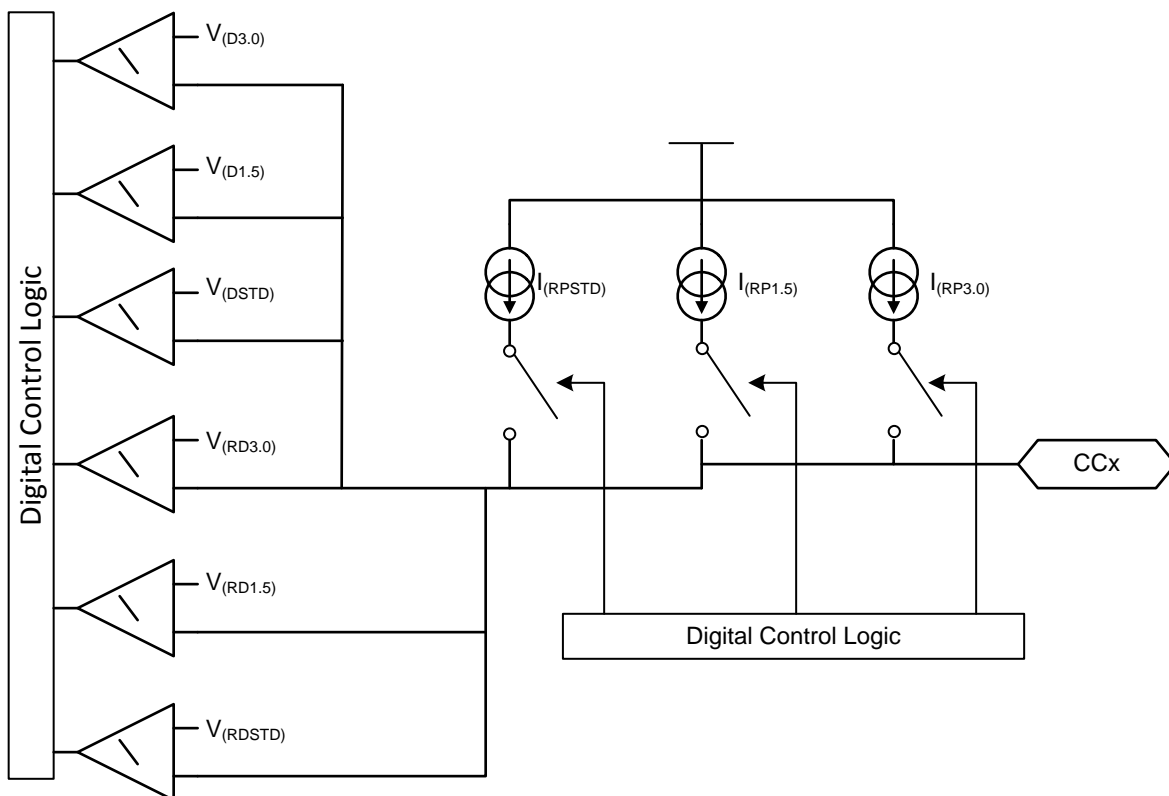

Figure 23. USB Type-C Rp Current Sources and Detection Comparators

If the voltage on both CC pins remains above $V_{(RDSTD)}$ for t_{CcDeb} , then the device goes to the sleep mode. In the sleep mode a less accurate current source is applied and a less accurate comparator watches for attachment (see $V_{(WAKE)}$, and $I_{(DSDFP)}$).

8.3.3 USB PD BMC Transmission (CC1, CC2, VTX)

An example of the BMC signal, specifically the end of the preamble and beginning of start-of-packet (SOP) is shown below. There is always an edge at the end of each bit or unit interval, and ones have an edge half way through the unit interval.

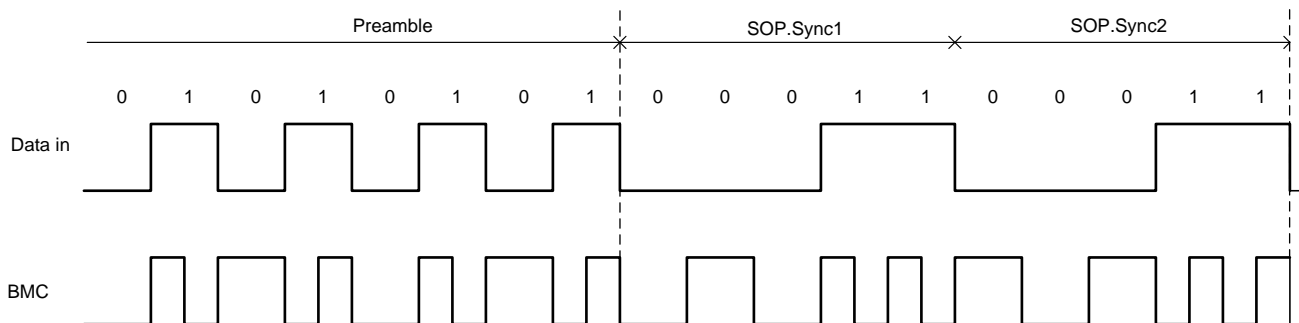

Figure 24. BMC Encoded End of Preamble, Beginning of SOP

Feature Description (continued)

While engaging in USB PD communications, the device is applying $I_{(RP1.5)}$ or $I_{(RP3.0)}$, so the CC line has a DC voltage of 0.918 V or 1.68 V, respectively. When the BMC signal is transmitted on the CC line, the transmitter overrides this DC voltage as shown in Figure 25. The transmitter bias rail (VTX) is internally generated and may not be used for any other purpose in the system. The VTX pin is only high while the TPS25740B is transmitting a USB PD message.

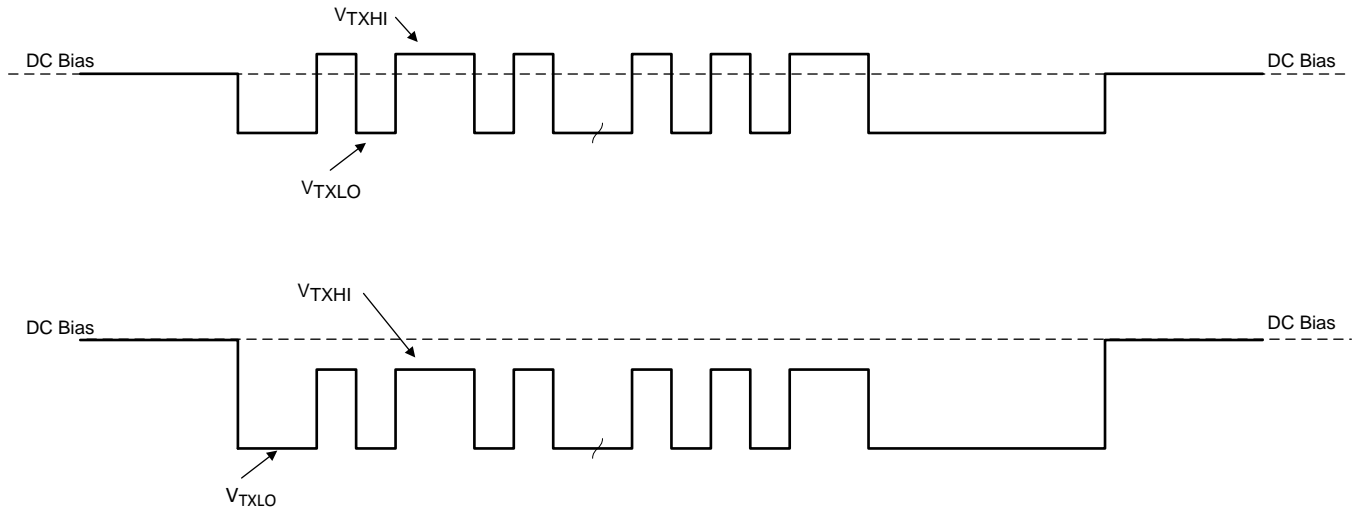
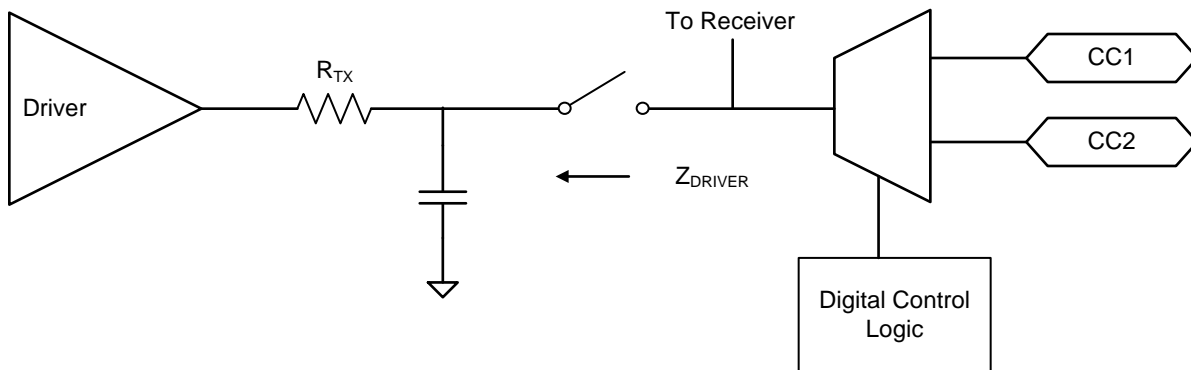

Figure 25. USB PD BMC Transmission on the CC Line

The device transmissions meet the eye diagram USB PD requirements (refer to USB PD in [Documentation Support](#)) across the recommended temperature range. Figure 26 shows the transmitter schematic.



Copyright © 2016, Texas Instruments Incorporated

Figure 26. USB PD BMC Transmitter Schematic

The transmit eye diagram shown in Figure 28 was measured using the test load shown in Figure 27 with a C_{LOAD} within the allowed range. The total capacitance C_{LOAD} is computed as:

$$C_{LOAD} = C_{(RX)} + C_{CablePlug} \times 2 + C_a + C_{Receiver} \tag{1}$$

Where:

- $200 \text{ pF} < C_{(RX)} < 600 \text{ pF}$
- $C_{CablePlug} < 25 \text{ pF}$
- $C_a < 625 \text{ pF}$
- $200 \text{ pF} < C_{Receiver} < 600 \text{ pF}$

Therefore, $400 \text{ pF} < C_{LOAD} < 1850 \text{ pF}$.

Feature Description (continued)

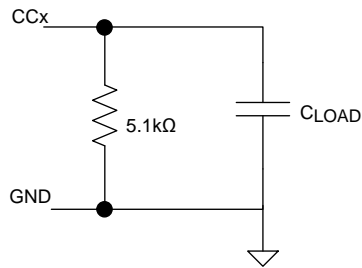

Copyright © 2016, Texas Instruments Incorporated

Figure 27. Test Load for BMC Transmitter

Figure 28 shows the transmit eye diagram for the TPS25740B.

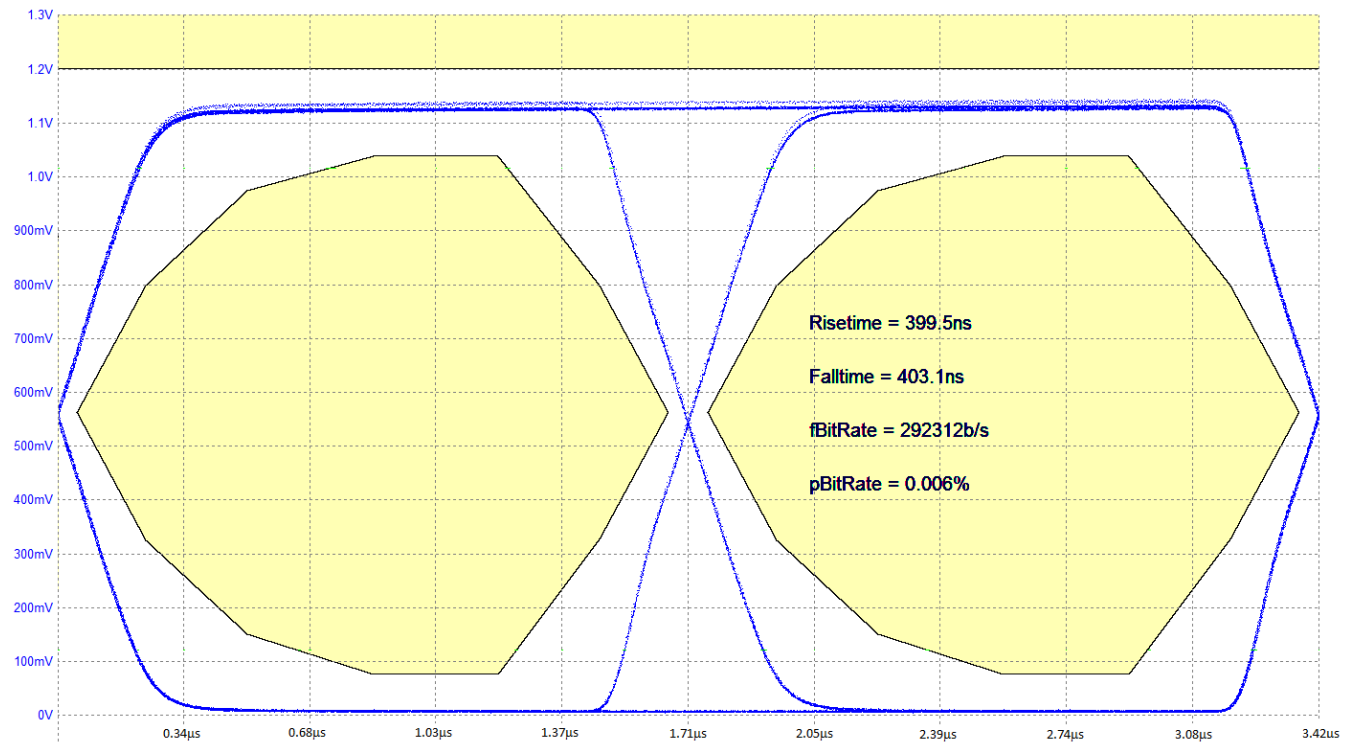

Figure 28. Transmit Eye Diagram (BMC)

Feature Description (continued)

8.3.4 USB PD BMC Reception (CC1, CC2)

The device BMC receiver follows the USB PD requirements (refer to USB PD in [Documentation Support](#)) using the schematic shown in [Figure 29](#).

The device low-pass filter design and receiver threshold design allows it to reject interference that may couple onto the CC line from a noisy VBUS power supply or any other source (refer to $V_{(INT)}$).

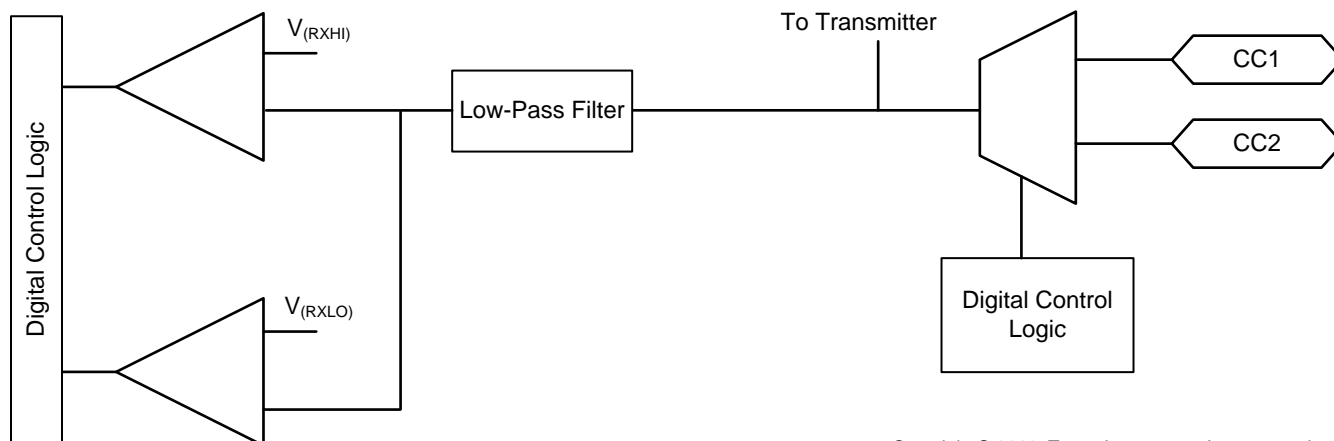

Copyright © 2016, Texas Instruments Incorporated

Figure 29. USB PD BMC Receiver Schematic

8.3.5 Discharging (DSCG, VPWR)

The DSCG pin allows for two different pull-downs that are used to apply different discharging strengths. In addition, the VPWR pin is used to apply a load to discharge the power supply bulk capacitance.

If too much power is dissipated by the device (that is, the T_{J1} temperature is exceeded) an OTSD occurs that disables the discharge FET; therefore, an external resistor is recommended in series with the DSCG pin to absorb most of the dissipated power. The external resistor $R_{(DSCG)}$ should be chosen such that the current sunk by the DSCG pin does not exceed $I_{(DSCGT)}$.

The VPWR pin should always be connected to the supply side (as opposed to the connector side) of the power-path switch ([Figure 30](#) shows one example). This pin is monitored before enabling the GDNG gate driver to apply the voltage to the VBUS pin of the connector.

From sink attachment, and while the device has not finalized a USB PD contract, the device applies $R_{(DSCGB)}$.

Also from sink attachment, and while the device has not finalized a USB PD contract, the device draws $I_{(SUPP)}$ through the VPWR pin even if VDD is above its UVLO. This helps to discharge the power supply source.

Feature Description (continued)

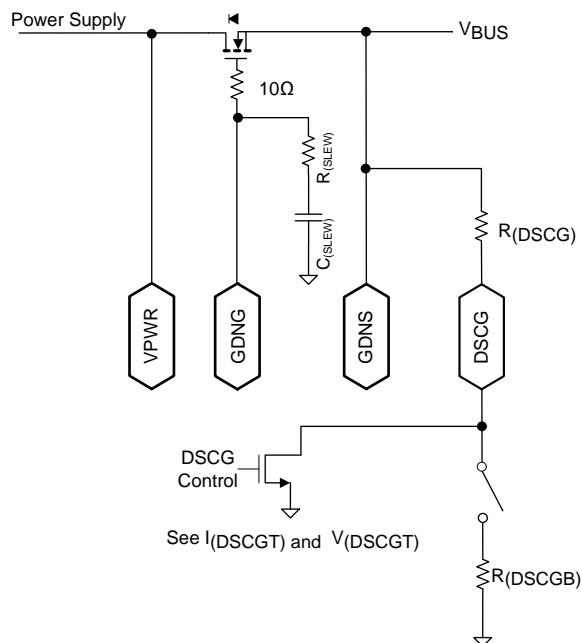

Copyright © 2016, Texas Instruments Incorporated

Figure 30. Discharge Schematic

The discharge procedure used in the device is intended to allow the DSCG pin to help pull the power supply down from high voltage, and then also pull VBUS at the connector down to the required level (refer to USB PD in [Documentation Support](#)).

8.3.5.1 Discharging after a Fault (VPWR)

There are two types of faults that cause the TPS25740B to begin a full discharge of VBUS: Slow-shutdown faults and fast-shutdown faults. When a slow-shutdown fault occurs, the device does not disable GDNG until after VBUS is measured below $V_{(SOVP)}$ for a 5V contract. When a fast-shutdown fault occurs, the device disables GDNG immediately and then discharges the connector side of the power-path. In both cases, the bleed discharge is applied to the DSCG pin and $I_{(SUPP)}$ is drawn from the VPWR

Slow-shutdown faults that do not include transmitting a hard reset:

- Receiving a Hard Reset signal ($25\text{ ms} < t_{\text{ShutdownDelay}} < 35\text{ ms}$)
- Cable is unplugged ($t_{\text{ShutdownDelay}} < 20\text{ }\mu\text{s}$)

Slow-shutdown faults that include transmitting hard reset ($25\text{ ms} < t_{\text{ShutdownDelay}} < 35\text{ ms}$)

- T_J exceeds T_{J1} (an overtemperature event)
- Low voltage alarm occurring outside of a voltage transition
- High voltage alarm occurring outside of a voltage transition (but not high enough to cause OVP)
- Receiving an unexpected PD message during a voltage transition
- Failure of power supply to transition voltages within required time of 600 ms ($t_{\text{PSTransition}}$ (refer to USB PD in [Documentation Support](#)).
- A Soft Reset USB PD message is not acknowledged or Accepted (refer to USB PD in [Documentation Support](#)).
- A Request USB PD message is not received in the required time (refer to USB PD in [Documentation Support](#)).
- Failure to discharge down to 0.725 V after a fault of any kind.

Feature Description (continued)

Fast-shutdown faults (hard reset always sent):

- Fast OVP event occurring at any time.
- OCP event occurring at any time starting from the transmission of the first USB PD message.
 - VBUS falling below $V_{(VBUS_FTH)}$ is treated as an OCP event.
- \overline{GD} falling edge

The DSCG pin is used to discharge the supply line after a slow-shutdown fault occurs. Figure 31 illustrates the signals involved. Depending on the specific slow-shutdown fault the time $t_{ShutdownDelay}$ in Figure 31 is different as indicated in the list above. If the slow-shutdown fault triggers a hard reset, it is sent at the beginning of the $t_{ShutdownDelay}$ period. However, the device behavior after the time $t_{ShutdownDelay}$ is the same for all slow-shutdown faults. After the $t_{ShutdownDelay}$ period, the device sets CTL1, CTL2, and CTL3 to select 5 V from the power supply and puts the DSCG pin into its ON state (Full Discharge). This discharging continues until the voltage on the VBUS pin reaches $V_{(SOVP)}$ for a 5-V contract. The device then disables GDNG and again puts the DSCG pin into its ON state. This discharging state lasts until the voltage on VBUS reaches 0.725 V (nominal). If the discharge does not complete within 650 ms, then the device sends a Hard Reset signal and the process repeats. In Figure 31, the times labeled as $t_{15 \rightarrow 5}$ and $t_{5 \rightarrow 0}$ can vary, they depend on the size of the capacitance to be discharged and the size of the external resistor between the DSCG pin and VBUS. The time labeled as t_S is a function of how quickly the NFET opens.

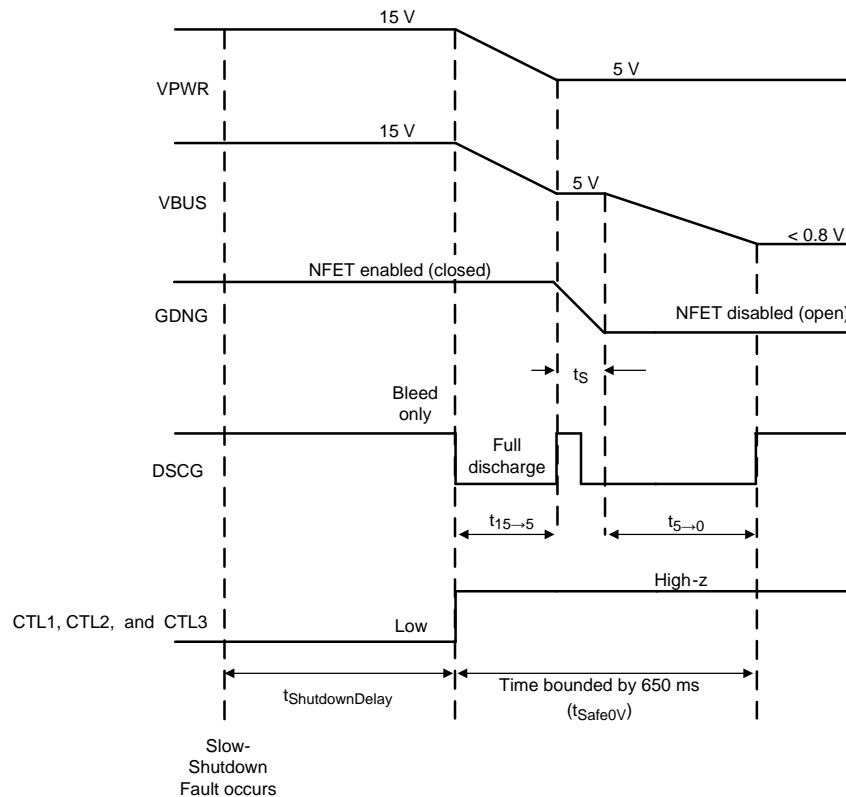

Figure 31. Illustration of Slow-Shutdown VBUS Discharge

Figure 32 illustrates a similar discharge procedure for fast-shutdown faults. The main difference from Figure 31 is that the NFET is opened immediately. It is assumed for the purposes of this illustration that the power supply output capacitance (that is, $C_{(SOURCE)}$ in the reference schematics shown in Figure 21 and Figure 22) is not discharged by the power supply itself, but the VPWR pin is bleeding current from that capacitance. The VPWR pin then draws $I_{(SUPP)}$ after GDNG disables the external NFET. So, as shown in the figure, the VPWR voltage discharges slowly, while the VBUS pin is discharged once the full discharge is enabled. If the voltage on the VPWR pin takes longer than $t_{15 \rightarrow 5} + t_{5 \rightarrow 0} + 0.765s$ to discharge below $V_{(FOVP)}$, then it causes an OVP event and the process repeats.

Feature Description (continued)

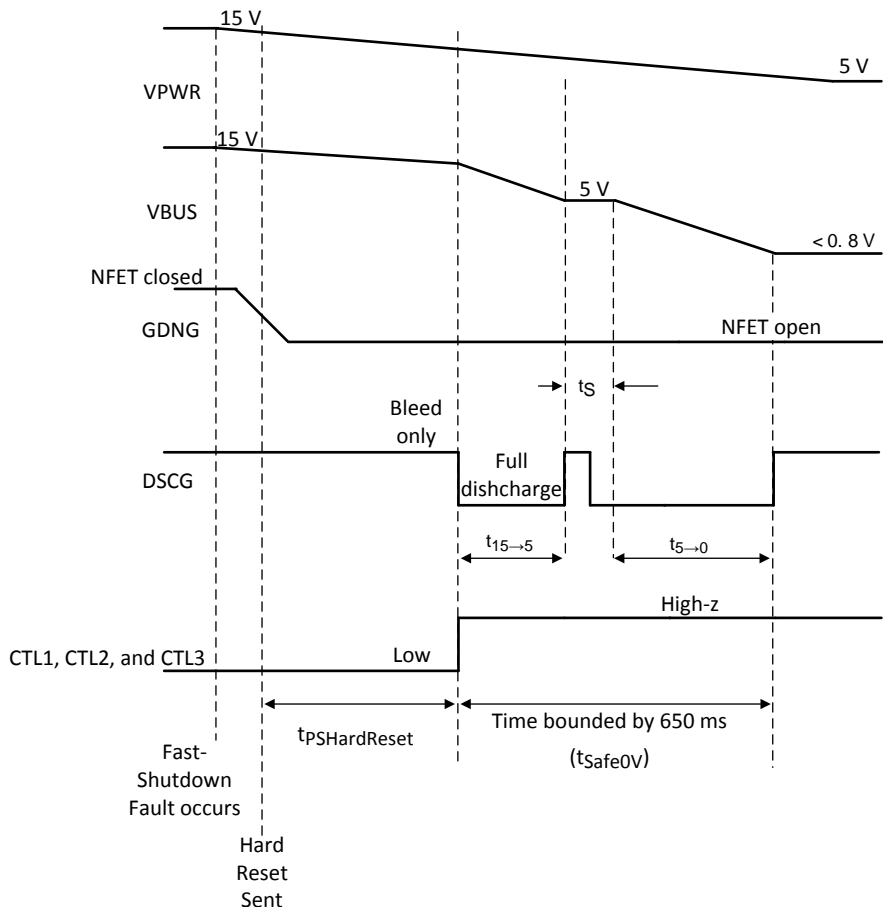

Figure 32. Illustration of Fast-Shutdown Discharge

If the discharge does not complete successfully it is treated as a slow-shutdown fault, and the device repeats the discharge procedure until it does complete successfully. Once the discharge completes successfully as described above (that is, VBUS on connector is below 0.725 V), the device waits for 0.765 s (nominal) before trying to source VBUS again.

8.3.6 Configuring Voltage Capabilities (HIPWR)

The voltages advertised to USB PD-capable sinks can be configured to one of two different sets. Note that changing the state of the PCTRL pin forces capabilities to be re-transmitted. The device reads the HIPWR pin after a reset and latches the result.

Table 1. Voltage Programming (TPS25740B)

HIPWR PIN	VOLTAGES ADVERTISED via USB PD [V]
Connected to DVDD or GND directly	5, 9, 15, 20
Connected to DVDD or GND via $R_{(SEL)}$	5, 9, 12, 15

8.3.7 Configuring Power Capabilities (PSEL, PCTRL, HIPWR)

The power advertised to non-PD Type-C Sinks is always 15 W. However, the device only advertises Type-C default current until it debounces the Sink attachment for t_{CcDeb} and the VBUS voltage has been given t_{VP} to stabilize.

The device does not communicate with the cable to determine its capabilities. Therefore, unless the device is in a system with a captive cable able to support 5 A, the HIPWR pin should be used to limit the advertised current to 3 A.

PCTRL is an input pin used to control how much of the maximum allowed power the port will advertise. This pin may be changed dynamically in the system and the device automatically updates any existing USB PD contract. If the PCTRL pin is pulled below $V_{(PCTRL_TH)}$, then the source capabilities offers half of the maximum power specified by the PSEL pin.

The devices read the PSEL and HIPWR pins after a reset and latches the result, but the PCTRL pin is read dynamically by the device and if its state changes new capabilities are calculated and then transmitted.

While USB PD allows advertising a power of 100 W, UL certification for Class 2 power units (UL 1310) requires the maximum power remain below 100 W. The device only advertises up to 4.65 A for a 20-V contract, this allows the V_{BUS} overshoot to reach 21.5 V as allowed by USB PD while remaining within the UL certification limits. Therefore, the device allows delivering 100 W of power without adding additional voltage tolerance constraints on the power supply.

The PSEL pin offers four possible maximum power settings, but the devices can actually advertise more power settings depending upon the state of the HIPWR and PCTRL pins. [Table 2](#) summarizes the four maximum power settings that are available via PSEL, again note this is not necessarily the maximum power that is advertised.

Table 2. PSEL Configurations

MAXIMUM POWER (PSEL) [W]	PSEL
$P_{(SEL)} = 36$	Direct to GND
$P_{(SEL)} = 45$	DVDD via $R_{(SEL)}$
$P_{(SEL)} = 65$	GND via $R_{(SEL)}$
$P_{(SEL)} = 93$	Direct to DVDD

[Equation 2](#) provides a quick reference which applies to device to see how the HIPWR, PSEL and PCTRL pins affect what current is advertised with each voltage in the source capabilities message:

$$I_x = \min\left(\frac{P_{max}}{V_{max}}, I_{max}\right) \quad (2)$$

Where:

- For a voltage V_x , the advertised current is I_x
- If the PCTRL pin is low, then $P_{max} = P_{(SEL)} / 2$
- If the PCTRL pin is high, then $P_{max} = P_{(SEL)}$.
- If the HIPWR pin is pulled high, then $I_{max} = 3$ A.
- If the HIPWR pin is pulled low, then $I_{max} = 5$ A.

[Table 3](#) provides a comprehensive list of the currents and voltages that are advertised for each voltage.

Table 3. Maximum Current Advertised in the Power Data Object for a Given Voltage

PSEL	VOLTAGE [V]	HIPWR	MAXIMUM CURRENT PCTRL = LOW [A]	MAXIMUM CURRENT PCTRL = HIGH [A]
Direct to GND	5	Max = 3 A DVDD through R _(SEL) or Direct to DVDD	3	3
DVDD via R _(SEL)			3	3
GND via R _(SEL)			3	3
Direct to DVDD			3	3
Direct to GND	9		2	3
DVDD via R _(SEL)			2.5	3
GND via R _(SEL)			3	3
Direct to DVDD			3	3
Direct to GND	12		1.5	3
DVDD via R _(SEL)			1.87	3
GND via R _(SEL)			2.7	3
Direct to DVDD			3	3
Direct to GND	15		1.2	2.4
100kΩ to DVDD			1.5	3
100kΩ to GND			2.17	3
Direct to DVDD			3	3
Direct to GND	20		0.9	1.8
DVDD via R _(SEL)			1.12	2.24
GND via R _(SEL)			1.62	3
Direct to DVDD			2.32	3
Direct to GND	5	Max = 5 A GND through R _(SEL) or Direct to GND	3.6	5
DVDD via R _(SEL)			4.5	5
GND via R _(SEL)			5	5
Direct to DVDD			5	5
Direct to GND	9		2	4
DVDD via R _(SEL)			2.5	5
GND via R _(SEL)			3.61	5
Direct to DVDD			5	5
Direct to GND	12		1.5	3
DVDD via R _(SEL)			1.87	3.74
GND via R _(SEL)			2.7	5
Direct to DVDD			4.16	5
Direct to GND	15		1.2	2.4
100kΩ to DVDD			1.5	3
100kΩ to GND			2.17	4.33
Direct to DVDD			3.1	5
Direct to GND	20		0.9	1.8
DVDD via R _(SEL)			1.12	2.24
GND via R _(SEL)			1.62	3.24
Direct to DVDD			2.32	4.64

8.3.8 Gate Driver (GDNG, GDNS)

The GDNG and GDNS pins may control a single NFET or back-to-back NFETs in a common-source configuration. The GDNS is used to sense the voltage so that the voltage differential between the pins is maintained.

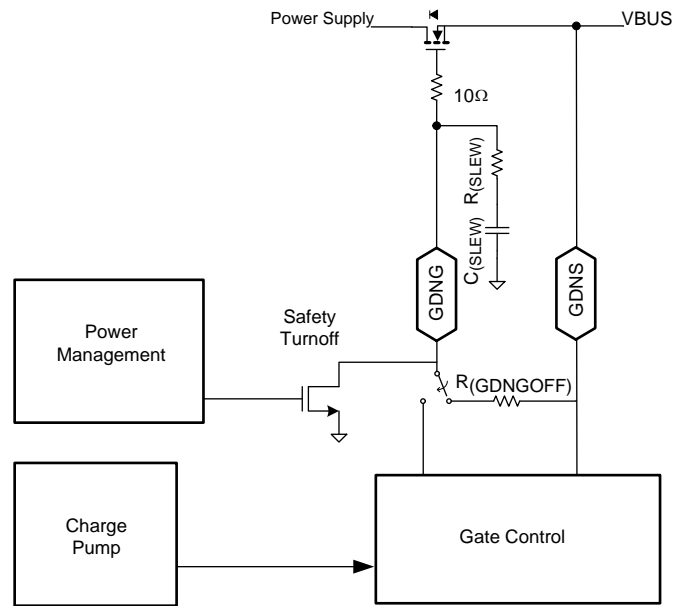

Copyright © 2016, Texas Instruments Incorporated

Figure 33. GDNG/GDNS Gate Control

8.3.9 Fault Monitoring and Protection

8.3.9.1 Over/Under Voltage (VBUS)

The TPS25740B uses the VBUS pin to monitor for overvoltage or undervoltage conditions and implement the fast-OVP, slow-OVP and slow-UVP features.

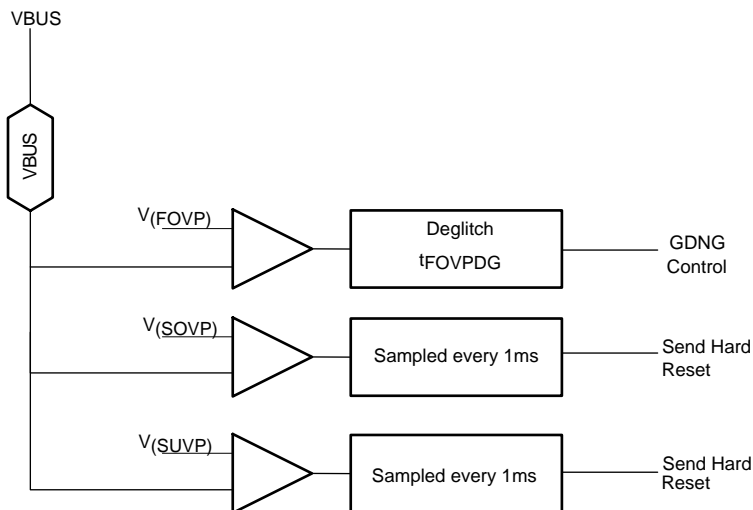

Copyright © 2016, Texas Instruments Incorporated

Figure 34. Voltage Monitoring Circuits

If an over-voltage condition is sensed by the Fast OVP mechanism, GDNG is disabled within $t_{FOVP} + t_{FOVPDG}$, then a Hard Reset is transmitted and the VBUS discharge sequence is started. At power up the voltage trip point is set to $V_{(FOVP)}$ (5 V contract). When a contract is negotiated the trip point is set to the corresponding $V_{(FOVP)}$ value.

The devices employ another slow over-voltage protection mechanism as well that sends the Hard Reset before disabling the external NFET. It catches many OV events before the Fast OVP mechanism. During intentional positive voltage transitions, this mechanism is disabled (see Figure 1). However, t_{VP} after the external NFET has been enabled, if the voltage on the VBUS pin exceeds $V_{(SOVP)}$ then a Hard Reset is transmitted to the Sink and the VBUS discharge sequence is started.

The devices employ a slow under-voltage protection mechanism as well that sends the Hard Reset before disabling GDNG. During intentional negative voltage transitions, this mechanism is disabled (see Figure 1). However, t_{VP} after the external NFET has been enabled if the voltage on the VBUS pin falls below $V_{(SUVP)}$, then a Hard Reset is transmitted to the Sink and the VBUS discharge sequence is started.

8.3.9.2 Over-Current Protection (ISNS, VBUS)

OCP protection is enabled t_{VP} after the voltage on the VBUS pin has exceeded $V_{(VBUS_RTH)}$. Prior to OCP being enabled, the GD pin can be used to protect against a short.

The OCP protection circuit monitors the differential voltage across an external sense resistor to detect when the current outflow exceeds $V_{I(TRIP)}$ which in turn activates an over-current circuit breaker and disables the GDNG / GDNS gate driver. Once the OCP is enabled, if the voltage on the VBUS pin falls below $V_{(VBUS_FTH)}$ then that is also treated like an OCP event.

Following the recommended implementation of a 5-mΩ sense resistor, when the device is configured to deliver 3 A (via HIPWR pin), the OCP threshold lies between 3.8 A and 4.5 A. When configured to deliver 5 A (via HIPWR pin), the OCP threshold lies between 5.8 A and 6.8 A. The resistance of the sense resistor may be tuned to adjust the current that causes $V_{I(TRIP)}$ to be exceeded.

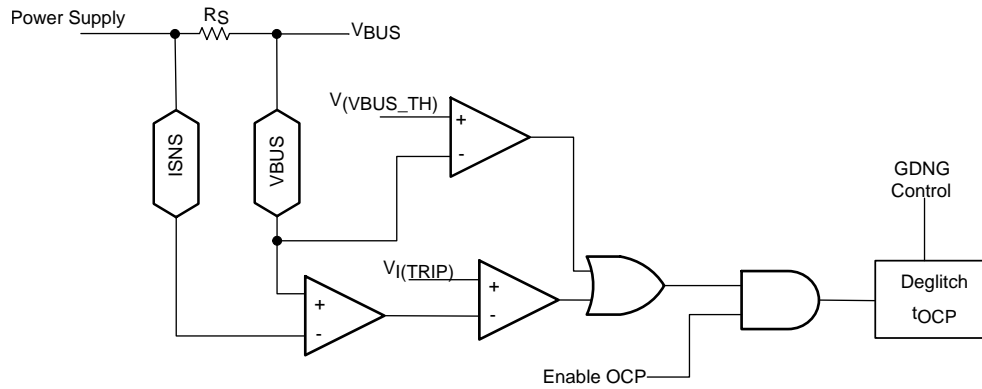

Copyright © 2016, Texas Instruments Incorporated

Figure 35. Overcurrent Protection Circuit, (ISNS, VBUS)

8.3.9.3 System Fault Input ($\overline{\text{GD}}$, VPWR)

The gate-driver disable pin provides a method of overriding the internal control of GDNG and GDNS. A falling edge on $\overline{\text{GD}}$ disables the gate driver within t_{GDoff} . If $\overline{\text{GD}}$ is held low after a sink is attached for 600 ms then a hard reset will be generated and the device sends a hard reset and go through its startup process again.

The $\overline{\text{GD}}$ input can be controlled by a voltage or current source. An internal voltage clamp is provided to limit the input voltage in current source applications. The clamp can safely conduct up to 80 μA and will remain high impedance up to 6.5 V before clamping.

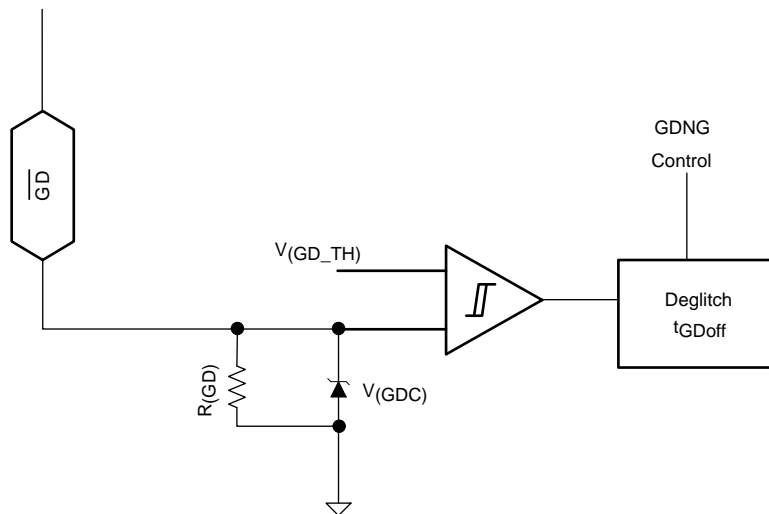

Copyright © 2016, Texas Instruments Incorporated

Figure 36. Overcurrent Protection Circuit, ($\overline{\text{GD}}$)

If the VPWR pin remains below its falling UVLO threshold ($V_{(\text{VPWR_TH})}$) for more than 600 ms after a sink is attached then the devices consider it a fault and will not enable GDNG. If the VPWR pin is between the rising and falling UVLO threshold, the device may enable GDNG and proceed with normal operations. However, after GDNG is enabled, if the VBUS pin does not rise above its UVLO within 190 ms the devices consider it a fast-shutdown fault and disables GDNG. Therefore, in order to ensure USB Type-C compliance and normal operation, the VPWR pin must be above its rising UVLO threshold ($V_{(\text{VPWR_TH})}$) within 275 ms of when ENSRC is pulled low and the VBUS pin must be above $V_{(\text{VBUS_RTH})}$ within 190 ms of GDNG being enabled.

8.3.10 Voltage Control (CTL1, CTL2, CTL3)

CTL1, CTL2, and CTL3 are open-drain output pins used to control an external power supply as summarized in [Table 4](#). Depending upon the voltage requested by the sink, the device sets the CTL pins accordingly. No current flows into the pin in its high-z state.

Table 4. States of CTL1, CTL2, and CTL3 as a Function of Target Voltage on VBUS (TPS25740B)

VOLTAGE CONTAINED in PDO REQUESTED by UFP	CTL3 STATE	CTL2 STATE	CTL1 STATE
5 V	High-z	High-z	High-z
9 V	High-z	Low	High-z
12 V (if 12 V enabled by HIPWR pin) 15 V (if 20 V enabled by HIPWR pin)	High-z	Low	Low
15 V (if 12V enabled by HIPWR pin) 20 V (if 20 V enabled by HIPWR pin)	Low	Low	Low

8.3.11 Sink Attachment Indicator (DVDD)

DVDD is a power supply pin that is high-z until a sink or debug accessory or audio accessory is attached, in which case it is pulled high. Therefore, it can be used as a sink attachment indicator that is active high.

8.3.12 Power Supplies (VAUX, VDD, VPWR, DVDD)

The VAUX pin is the output of a linear regulator and the input supply for internal power management circuitry. The VAUX regulator draws power from VDD after establishing a USB PD contract unless it is not available in which case it draws from VPWR. Changes in supply voltages will result in seamless switching between supplies.

If there is a load on the DVDD pin, that current will be drawn from the VPWR pin unless the device has stabilized into a USB PD contract or VPWR is below its UVLO.

Connect VAUX to GND via the recommended bypass capacitor. Do not connect any external load that draws more than $I_{(VAUXEXT)}$. Locate the bypass capacitor close to the pin and provide a low impedance ground connection from the capacitor to the ground plane.

VDD should either be grounded or be fed by a low impedance path and have input bypass capacitance. Locate the bypass capacitors close to the VDD and VPWR pins and provide a low impedance ground connection from the capacitor to the ground plane.

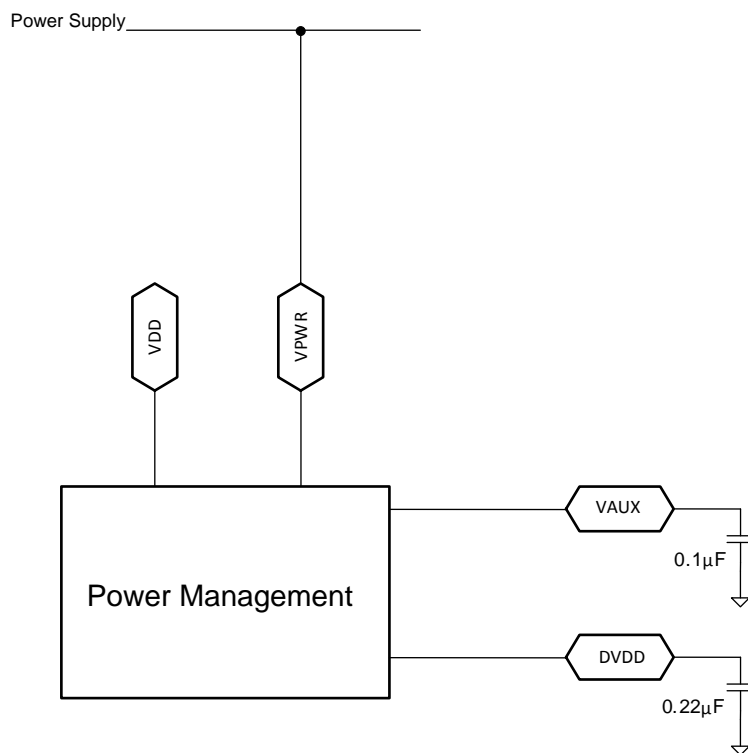

Copyright © 2016, Texas Instruments Incorporated

Figure 37. Power Management

8.3.13 Grounds (AGND, GND)

GND is the substrate ground of the die. Most circuits return to GND, but certain analog circuitry returns to AGND to reduce noise and offsets. The power pad (on those devices that possess one) is electrically connected to GND. Connect AGND, GND and the power pad (if present) to the ground plane through the shortest and most direct connections possible.

8.3.14 Output Power Supply (DVDD)

The DVDD pin is the output of an internal 1.85 V linear regulator, and the input supply for internal digital circuitry. This regulator normally draws power from VPWR until a USB PD contract has stabilized, but will seamlessly swap to drawing power from VDD in the event that VPWR drops below its UVLO threshold. External circuitry can draw up to 35 mA from DVDD. Note that as more power is drawn from the DVDD pin more heat is dissipated in the device, and if excessive the OTSD could be tripped which resets the device. Connect DVDD to GND via the recommended ceramic bypass capacitor.

The DVDD pin will only be high when a USB Type-C sink, or audio accessory, or debug accessory is attached, refer to [Figure 19](#) and [Figure 20](#).

Locate the bypass capacitor close to the pin and provide a low impedance ground connection from the capacitor to the ground plane.

8.4 Device Functional Modes

8.4.1 Sleep Mode

Many adaptors that include USB PD must consume low quiescent power to meet regulatory requirements (that is, “Green,” Energy Star, or such). The device supports the sleep mode to minimize power consumption when the receptacle or plug is unattached. The device enters sleep mode when there is no valid plug termination attached; a valid plug termination is defined as one of: sink, Audio accessory, or Debug accessory. If an active cable is attached but its far-end is left unconnected or “dangling,” then the device also enters sleep mode. It exits the sleep mode whenever the plug status changes, that could be a dangling cable being removed or a sink being connected.

8.4.2 Checking VBUS at Start Up

When first powered up, the device will not enable GDNG if the voltage on VBUS is already above its UVLO. This is a protective measure taken to avoid the possibility of turning on while connected to another active power supply in some non-compliant configuration.

This means that the VBUS pin must be connected between the power-path NFET and the USB connector. This also allows for a controlled discharge of VBUS all the way down to the required voltage on the connector (refer to USB PD in [Documentation Support](#)).

9 Application and Implementation

NOTE

Information in the following applications sections is not part of the TI component specification, and TI does not warrant its accuracy or completeness. TI's customers are responsible for determining suitability of components for their purposes. Customers should validate and test their design implementation to confirm system functionality.

9.1 Application Information

The TPS25740B implements a fully compliant USB Power Delivery 2.0 provider and Type-C source (also known as downward facing port (DFP)). The device basic schematic diagram is shown in [Figure 38](#). Subsequent sections describe detailed design procedures for several applications with differing requirements. The TPS25740B Design Calculator Tool (refer to USB PD in [Documentation Support](#)) is available for download and use in calculating the equations in the following sections.

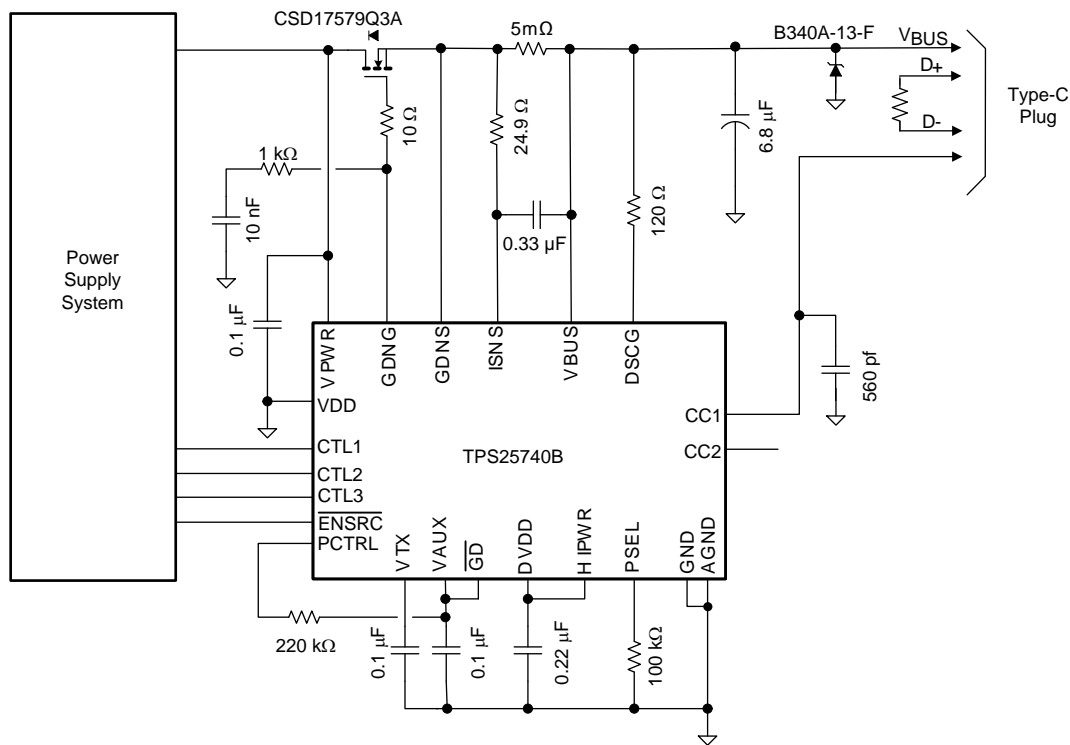

Copyright © 2016, Texas Instruments Incorporated

Figure 38. Basic Schematic Diagram ($P_{(SEL)} = 65\text{ W}$ at 5 V, 9 V, 15 V, 20 V)

9.1.1 System-Level ESD Protection

System-level ESD (per EN61000-4-2) may occur as the result of a cable being plugged in, or a user touching the USB connector or cable. [Figure 39](#) shows an example ESD protection for the VBUS path that helps protect the VBUS pin, ISNS and DSCG pins of the device from system-level ESD. The device has ESD protection built into the CC1 and CC2 pins so that no external protection is necessary. Refer to the [Layout Guidelines](#) section for external component placement and routing recommendations.

The Schottky diode is to protect against VBUS being drawn below ground by an inductive load, the cable inductance may be as high as 900 nH.

Application Information (continued)

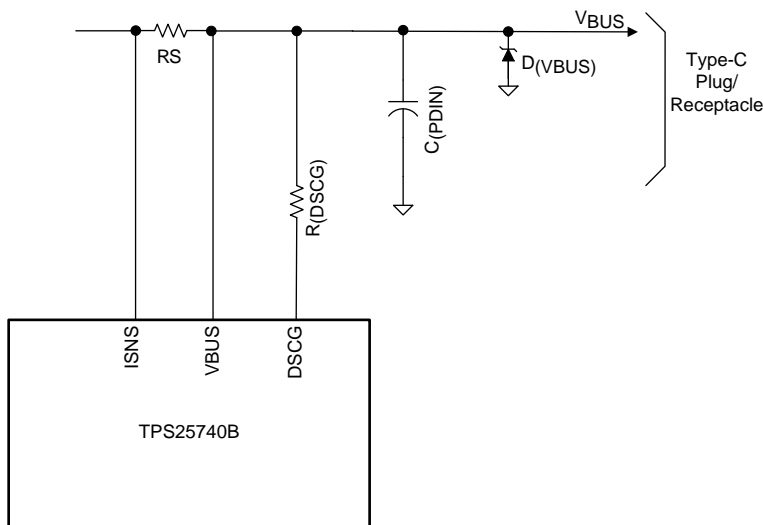

Copyright © 2016, Texas Instruments Incorporated

Figure 39. VBUS ESD Protection

9.1.2 Using ENSRC to Enable the Power Supply upon Sink Attachment

ENSRC may be connected to the enable pin of the power supply as shown in Figure 40. This configuration can eliminate the idle state power loss in the power supply by only turning it on when a sink is attached. In this configuration, VPWR must be connected to a live source so that the TPS25740B can wake upon sink attachment.

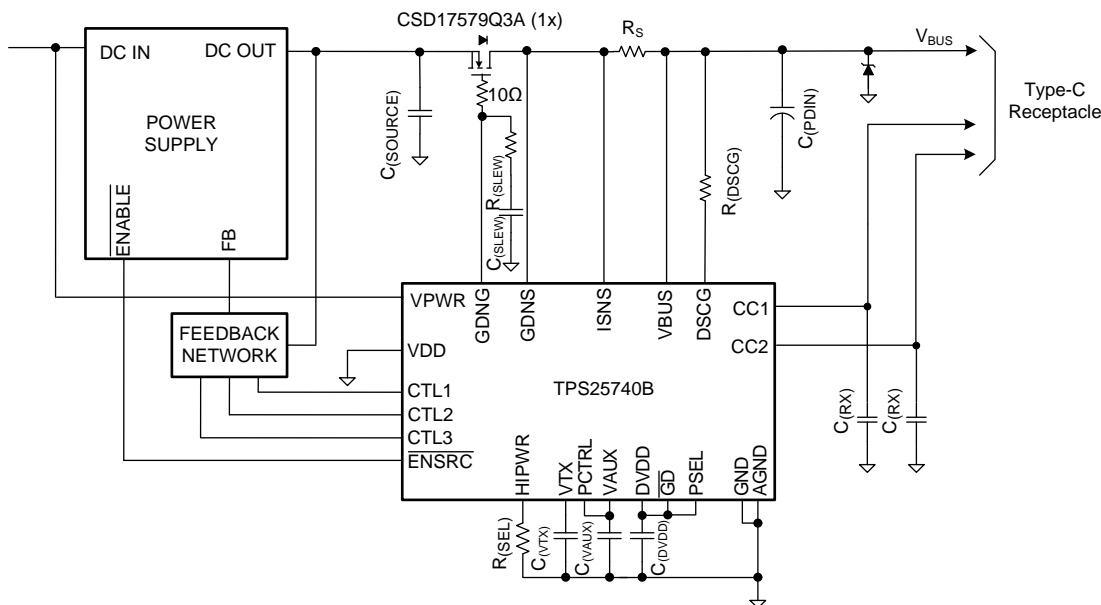

Copyright © 2017, Texas Instruments Incorporated

Figure 40. ENSRC as Power Supply Enable

Application Information (continued)

Another benefit of this configuration is that only one NFET is required to block the source capacitance of the power supply when the socket is cold. This requires that the NFET be oriented with drain towards the type C connector as shown in Figure 40. For this NFET orientation, TPS25740B cannot protect the power supply from over-current events, so the power supply must implement over-current protection. For this case, R_S may be removed with ISNS directly connected to VBUS. Since VBUS follows DC OUT, power supply start-up overshoot must be less than $V_{(SOVP5)}$. ENSRC is set to high-z after a delay of t_{HR} whenever TPS25740B detects a fault that requires a hard reset.

9.1.3 Use of \overline{GD} Internal Clamp

As described in the *Configuring Power Capabilities (PSEL, PCTRL, HIPWR)* section, the \overline{GD} pin has an internal clamp. Figure 41 shows an example of how it may be used. V_{OUT} is the voltage from a power supply that is to be provided onto the VBUS wire of the USB Type-C cable through an NFET resistor. If V_{OUT} drops, the NFET should be automatically disabled by the device. This can be accomplished by tying the \overline{GD} pin to V_{OUT} via a resistor.

The internal resistance of the \overline{GD} pin is specified to exceed $R_{(GD)}$, and the input threshold is $V_{(GD_TH)}$. The \overline{GD} pin would therefore draw no more than $V_{(GD_TH)\max} / R_{(GD)\min} < 603 \text{ nA}$. As an example, assume the minimum value of V_{OUT} for which \overline{GD} should be high is 4.5 V, then the resistor between \overline{GD} and V_{OUT} may not exceed $(4.5 - V_{(GD_TH)\max}) / 603e-9 = 4.5 \text{ M}\Omega$. To make it robust against board leakage a smaller resistor such as 1 M Ω can be chosen, but the smaller the resistance the more leakage current into the \overline{GD} pin. In this example, when V_{OUT} is 25 V, the current into the \overline{GD} pin is $(25 - V_{(GDC)}) / 1e6 < 1.85 \mu\text{A}$.

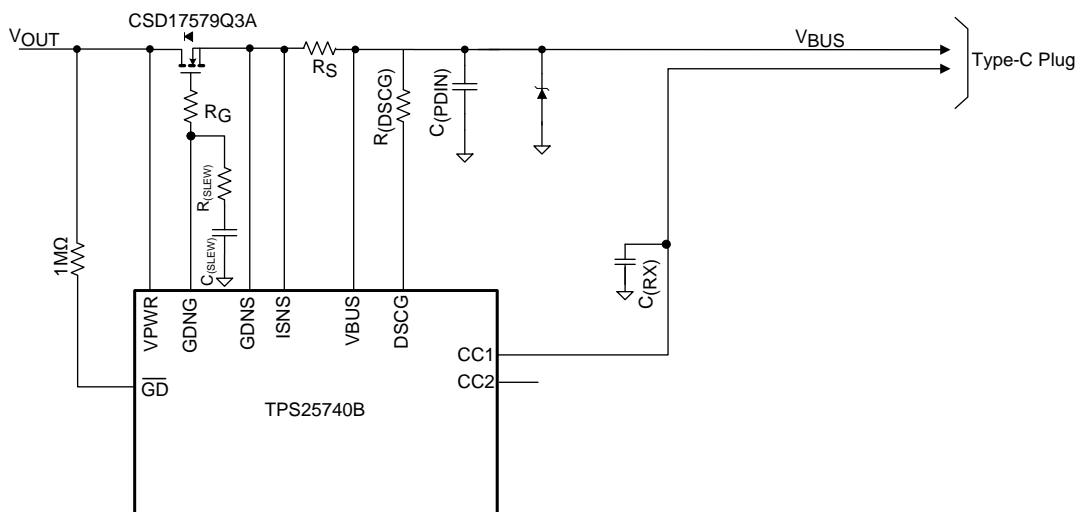

Copyright © 2016, Texas Instruments Incorporated

Figure 41. Use of \overline{GD} Internal Clamp

9.1.4 Resistor Divider on \overline{GD} for Programmable Start Up

Figure 42 shows an alternative usage of the \overline{GD} pin can help protect against shorts on the VBUS pin in the receptacle. A resistor divider is used to minimize the time it takes the \overline{GD} pin to be pulled low. Consider the situation where the VBUS pin is shorted at startup. At some point, the device closes the NFET switch to supply 5 V to VBUS. At that point, the short pulls down on the voltage seen at the VPWR pin. With the resistor values shown in Figure 42, once the voltage at the VPWR pin reaches 3.95 V the voltage at the \overline{GD} pin is specified to be below $V_{(GD_TH)\min}$. Without the 700-k Ω resistor, the voltage at the VPWR pin would have to reach $V_{(GD_TH)\min}$ which takes longer. This comes at the expense of increased leakage current.

Application Information (continued)

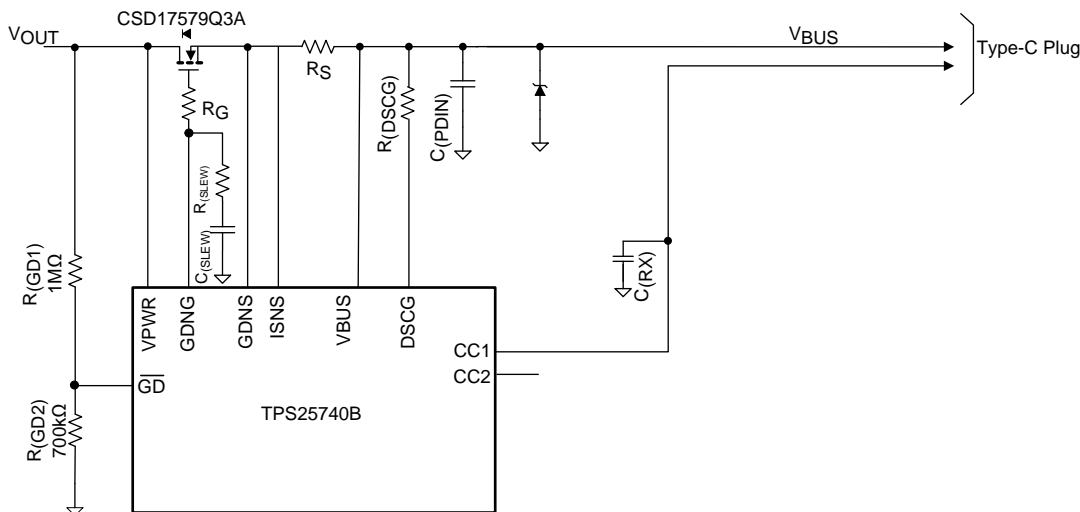

Copyright © 2016, Texas Instruments Incorporated

Figure 42. Programmable $\overline{\text{GD}}$ Turn On

The $\overline{\text{GD}}$ resistor values can be calculated using the following process. First, calculate the smallest $R_{(\text{GD}1)}$ that should be used to prevent the internal clamp current from exceeding $I_{(\text{GD})}$ of 80 μA . For a 20 V advertised voltage, the OVP trip point could be as high as 24 V. Using $V_{(\text{GDC}) \text{ min}} = 6.5 \text{ V}$ and $V_{\text{OUT}} = V_{(\text{FOVP}20) \text{ max}} = 24 \text{ V}$, provides Equation 3:

$$R_{(\text{GD}1)} > \frac{V_{(\text{FOVP}20)} - V_{(\text{GDC})}}{I_{(\text{GD})}} = \frac{24 \text{ V} - 6.5 \text{ V}}{80 \mu\text{A}} = 219 \text{ k}\Omega \tag{3}$$

The actual clamping current is less than 80 μA as some current flows into $R_{(\text{GD}2)}$. Next, $R_{(\text{GD}2)}$ can be calculated as shown in Equation 4:

$$R_{(\text{GD}2)} < R_{(\text{GD}1)} \times \frac{V_{(\text{GD_TH})}}{V_{(\text{VPWR})} - V_{(\text{GD_TH})}}$$

where

- $V_{(\text{VPWR})} = V_{(\text{VPWR_TH})}$ falling (max) and $V_{(\text{GD_TH})} = V_{(\text{GD_TH})}$ falling (min).

9.1.5 Selection of the CTL1, CTL2, and CTL3 Resistors ($R_{(\text{FBL}1)}$, $R_{(\text{FBL}2)}$, and $R_{(\text{FBL}3)}$)

$R_{(\text{FBL}1)}$, $R_{(\text{FBL}2)}$, and $R_{(\text{FBL}3)}$ provide a means to change the power supply output voltage when switched in by the CTL1, CTL2, and CTL3 open drain outputs, respectively. When CTLx is driven low it will place $R_{(\text{FBL}x)}$ in parallel with $R_{(\text{FBL})}$.

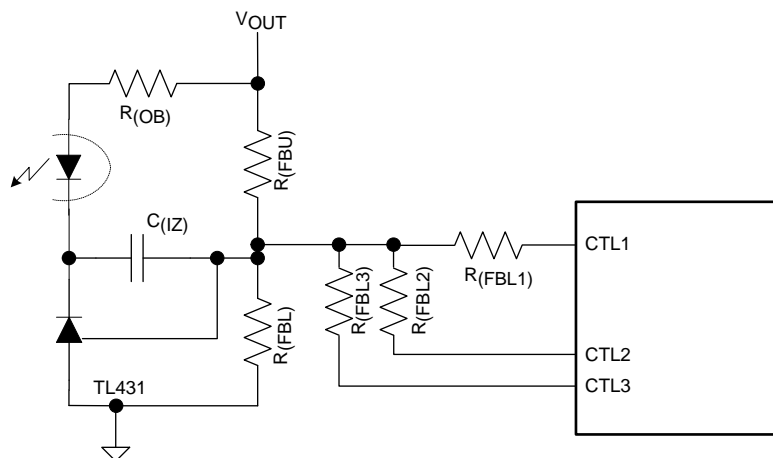
Application Information (continued)

Copyright © 2016, Texas Instruments Incorporated

Figure 43. Circuit to Change V_{OUT} Upon Sink/UFP Request

R_(FBL2) is calculated using Equation 5. In this example, V_{OUT9} is 9 V, V_{OUT15} is 15 V, and V_{OUT20} is 20 V. V_{OUT} is the default output voltage (5 V) for the regulator and is set by R_(FBU), R_(FBL) and error amplifier V_{REF}.

$$R_{(FBL2)} = \frac{R_{(FBL)} \times R_{(FBU)} \times V_{REF}}{R_{(FBL)} \times (V_{OUT9} - V_{REF}) - R_{(FBU)} \times V_{REF}} \quad (5)$$

R_(FBL1) is calculated using Equation 6 after a standard 1% value for R_(FBL2) is chosen.

$$R_{(FBL1)} = \frac{\frac{R_{(FBL2)} \times R_{(FBL)}}{R_{(FBL2)} + R_{(FBL)}} \times R_{(FBU)} \times V_{REF}}{\frac{R_{(FBL2)} \times R_{(FBL)}}{R_{(FBL2)} + R_{(FBL)}} \times (V_{OUT15} - V_{REF}) - R_{(FBU)} \times V_{REF}} \quad (6)$$

$$R_{(FBL3)} = \frac{\frac{R_{(FBL1)} \times R_{(FBL2)} \times R_{(FBL)}}{R_{(FBL)} \times (R_{(FBL2)} + R_{(FBL1)}) + R_{(FBL2)} \times R_{(FBL1)}} \times R_{(FBU)} \times V_{REF}}{\frac{R_{(FBL1)} \times R_{(FBL2)} \times R_{(FBL)}}{R_{(FBL)} \times (R_{(FBL2)} + R_{(FBL1)}) + R_{(FBL2)} \times R_{(FBL1)}} \times (V_{OUT20} - V_{REF}) - R_{(FBU)} \times V_{REF}} \quad (7)$$

R_(FBLx) resistors should be large enough so that the corresponding CTLx sinking current is minimized (< 1 mA). The sinking current for CTLx is V_{REF} / R_(FBLx).

9.1.6 Voltage Transition Requirements

During VBUS voltage transitions, the slew rate (v_{SrcSlewPos}) must be kept below 30 mV/μs in all portions of the waveform, settle (t_{SrcSettle}) in less than 275 ms, and be ready (t_{SrcReady}) in less than 285 ms. For most power supplies, these requirements are met naturally without any special circuitry but in some cases, the voltage transition ramp rate must be slowed in order to meet the slew rate requirement.

The requirements for linear voltage transitions are shown in Table 5. In all cases, the minimum slew time is below 1 ms.

Table 5. Minimum Slew-Rate Requirements

VOLTAGE TRANSITION	5 V ↔ 12 V	5 V ↔ 20 V	12 V ↔ 20 V	5 V ↔ 9 V	5 V ↔ 15 V	9 V ↔ 15 V	9 V ↔ 12 V	12 V ↔ 15 V	9 V ↔ 20 V	15 V ↔ 20 V
Minimum Slew Time	233 μs	500 μs	267 μs	133 μs	333 μs	200 μs	100 μs	100 μs	367 μs	167 μs

When transition slew control is required, the interaction of the slew mechanism and dc/dc converter loop response must be considered. A simple R-C filter between the device CTL pins and converter feedback node may lead to instability under some conditions. Figure 44 shows a method which controls the slew rate without adding capacitance to the converter feedback node.

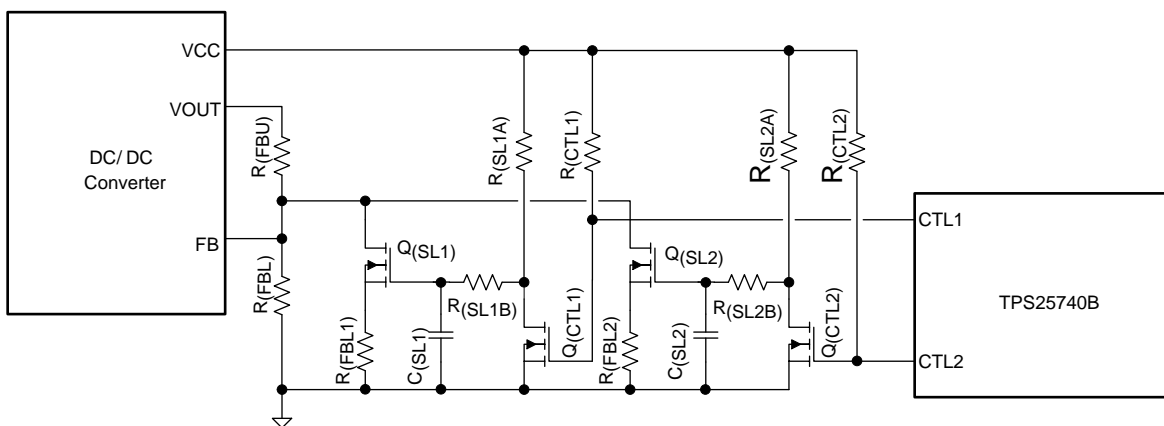

Copyright © 2016, Texas Instruments Incorporated

Figure 44. Slew-Rate Control Example No. 1

When $V_{OUT} = 5\text{ V}$, all CTL pins are in a high impedance state. When a 5 V to 12 V transition is requested, CTL2 goes low and turns off $Q_{(CTL2)}$. $Q_{(SL2)}$ gate starts to rise towards VCC at a rate determined by $R_{(SL2A)} + R_{(SL2B)}$ and $C_{(SL2)}$. $Q_{(SL2)}$ gate continues to rise, until $Q_{(SL2)}$ is fully enhanced placing $R_{(FBL2)}$ in parallel with $R_{(FBL)}$. In similar fashion when $C_{(TL1)}$ goes low, $Q_{(CTL1)}$ turns off allowing $R_{(FBL1)}$ to slew in parallel with $R_{(FBL2)}$ and $R_{(FBL)}$.

The slewing resistors and capacitor can be chosen using the following equations. V_T is the VGS threshold voltage of $Q_{(SL1)}$ and $Q_{(SL2)}$. V_{REF} is the feedback regulator reference voltage. Choose the slewing resistance in the 100 kΩ range to reduce the loading on the bias voltage source (VCC) and then calculate $C_{(SL)}$. The falling transitions is shorter than the rising transitions in this topology.

Falling transitions:

- 20 V to 12 V

$$R_{(SL1B)} \times C_{(SL1)} = \frac{\Delta T_{20V - 12V}}{\ln\left(\frac{V_T + V_{REF}}{V_{(VCC)}}\right) - \ln\left(\frac{V_T}{V_{(VCC)}}\right)} \quad (8)$$

- 12 V to 5 V

$$R_{(SL2B)} \times C_{(SL2)} = \frac{\Delta T_{12V - 5V}}{\ln\left(\frac{V_T + V_{REF}}{V_{(VCC)}}\right) - \ln\left(\frac{V_T}{V_{(VCC)}}\right)} \quad (9)$$

Rising transitions:

- 5 V to 12 V

$$(R_{(SL2A)} + R_{(SL2B)}) \times C_{(SL2)} = \frac{\Delta T_{5V - 12V}}{\ln\left(1 - \frac{V_T}{V_{(VCC)}}\right) - \ln\left(1 - \frac{V_T + V_{REF}}{V_{(VCC)}}\right)} \quad (10)$$

- 12 V to 20 V

$$(R_{(SL1A)} + R_{(SL1B)}) \times C_{(SL1)} = \frac{\Delta T_{12V - 20V}}{\ln\left(1 - \frac{V_T}{V_{(VCC)}}\right) - \ln\left(1 - \frac{V_T + V_{REF}}{V_{(VCC)}}\right)} \quad (11)$$

Some converter regulators can tolerate a balance of capacitance on the feedback node without affecting loop stability. The LM5175 has been tested using [Figure 45](#) to combine V_{OUT} slewing with a minimal amount of extra circuitry.

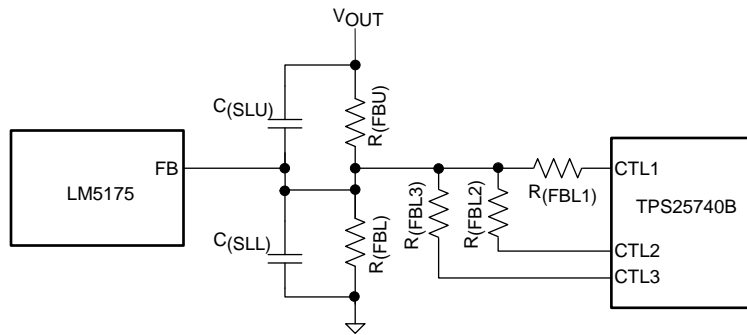

Copyright © 2016, Texas Instruments Incorporated

Figure 45. Slew-Rate Control Example No. 2

When a higher voltage is requested from TPS25740B, at least one of the CTL pins goes low changing the sensed voltage at the FB pin. The LM5175 compensates by increasing $C_{(SLU)}$. As V_{OUT} increases, $C_{(SLU)}$ is charged at a rate proportional to $R_{(FBU)}$. Three time constants yields a voltage change of approximately 95% and can be used to calculate the desired slew time. $C_{(SLU)}$ can be calculated using [Equation 12](#) and [Equation 13](#).

$$\Delta T_{(SLEW)} = 3 \times R_{(FBU)} \times C_{(SLU)} \tag{12}$$

$$C_{(SLU)} = \frac{\Delta T_{(SLEW)}}{3 \times R_{(FBU)}} \tag{13}$$

In order to minimize loop stability effects, a capacitor in parallel with $R_{(FBL)}$ is required. The ratio of $C_{(SLU)}/C_{(SLL)}$ should be chosen to match the ratio of $R_{(FBL)}/R_{(FBU)}$. Choose $C_{(SLL)}$ according to [Equation 14](#).

$$C_{(SLL)} = C_{(SLU)} \times \frac{R_{(FBU)}}{R_{(FBL)}} \tag{14}$$

A third slew rate method is shown in [Figure 46](#) using an equivalent resistance, R_{EQ} and $C_{(SLL)}$ to provide an exponential slew rate. The slew rate is the derivative of the voltage ramp with the maximum occurring at the beginning of a transition. A DC-DC converter with programmable soft-start can help minimize V_{OUT} overshoot at start-up due to $C_{(SLL)}$. Any V_{OUT} overshoot must decay below $V_{(SOVP5)}$ before TPS25740B applies V_{BUS} in order to prevent OVP shutdown.

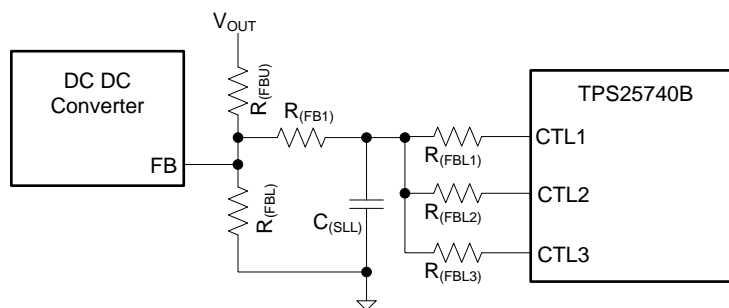

Copyright © 2017, Texas Instruments Incorporated

Figure 46. Slew-Rate Control Example No. 3

For the rising condition, TPS25740B will connect one or more of the $R_{(FBLx)}$ resistors in parallel with $C_{(SLL)}$. The FB node is treated as a virtual ground so that R_{EQ} for the rising condition is $R_{(FB1)}$ in parallel with the $R_{(FBLx)}$ resistors being grounded through the CTLx pins. For the falling condition, TPS25740B will disconnect one or more of the $R_{(FBLx)}$ resistors in parallel with $C_{(SLL)}$. R_{EQ} for the falling condition is therefore $R_{(FB1)}$ in parallel with the $R_{(FBLx)}$ resistors remaining grounded.

$$SR \left(\frac{\text{mV}}{\mu\text{s}} \right) = \frac{\Delta V_{\text{BUS}}}{1000 \times R_{\text{EQ}} \times C_{(\text{SLL})}} \times e^{\frac{-t}{R_{\text{EQ}} \times C_{(\text{SLL})}}}$$

where

- $SR = SR(\text{max})$ at $t = 0$ (15)

$$SR(\text{max}) \left(\frac{\text{mV}}{\mu\text{s}} \right) = \frac{\Delta V_{\text{BUS}}}{1000 \times R_{\text{EQ}} \times C_{(\text{SLL})}} \quad (16)$$

The slew rate is proportional to V_{BUS} voltage change and the largest slew rate occurs for the 5 V to 20 V case (or 15 V if 15 V is the highest advertised voltage) where all three $R_{(\text{FBL}x)}$ resistors are connected simultaneously. Size $C_{(\text{SLL})}$ for this case using $R_{\text{EQ}} = R_{(\text{FB1})}, R_{(\text{FBL1})}, R_{(\text{FBL2})},$ and $R_{(\text{FBL3})}$ in parallel.

For this method, the procedure to choose the voltage programming resistors differs from the examples in section [Selection of the CTL1, CTL2, and CTL3 Resistors \(\$R_{\(\text{FBL1}\)}, R_{\(\text{FBL2}\)},\$ and \$R_{\(\text{FBL3}\)}\$ \)](#) due to the addition of $R_{(\text{FB1})}$. The TPS25740B Design Calculator Tool (refer to USB PD in [Documentation Support](#)) is available to help with the calculations for this control method. All slew rate control methods should be verified on the bench to ensure that the slew rate requirements are being met when the external V_{BUS} capacitance is between 1 μF and 100 μF .

9.1.7 V_{BUS} Slew Control using GDNG $C_{(\text{SLEW})}$

Care should be taken to control the slew rate of Q1 using $C_{(\text{SLEW})}$; particularly in applications where $C_{\text{OUT}} \gg C_{(\text{SLEW})}$. The slew rate observed on V_{BUS} when charging a purely capacitive load is the same as the slew rate of $V_{(\text{GDNG})}$ and is dominated by the ratio $I_{(\text{GDNON})} / C_{(\text{SLEW})}$. $R_{(\text{SLEW})}$ helps block $C_{(\text{SLEW})}$ from the GDNG pin enabling a faster transient response to OCP.

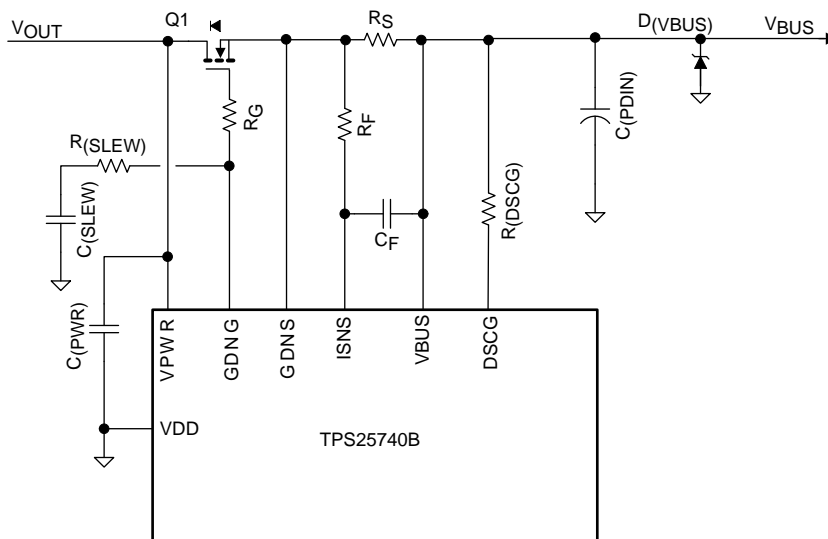

Copyright © 2016, Texas Instruments Incorporated

Figure 47. Slew-Rate control Using GDNG

There may be fault conditions where the voltage on V_{BUS} triggers an OVP condition and then remains at a high voltage even after the TPS25740B configures the voltage source to output 5 V via the CTL pins. When this OVP occurs, the TPS25740B opens Q1 within $t_{\text{FOVP}} + t_{\text{FOVPDG}}$. The TPS25740B then issues a hard reset, discharge the power-path via the $R_{(\text{DSCG})}$, and waits for 795 ms before enabling Q1 again. Due to the fault condition the voltage again triggers an OVP event when the voltage on V_{BUS} exceeds $V_{(\text{FOVP})}$. This retry process would continue as long as the fault condition persists, periodically pulsing up to $V_{(\text{FOVP})} + V_{\text{SrcSlewPos}} \times (t_{\text{FOVP}} + t_{\text{FOVPDG}})$ onto the V_{BUS} of the Type-C receptacle. It is recommended to use a slew rate less than the maximum of $V_{\text{SrcSlewPos}}$ (30 mV / μs) allowed by USB (refer to [Documentation Support](#)), the slew rate should instead be set in order to meet the requirement to have the voltage reach the target voltage within $t_{\text{SrcSettle}}$ (275 ms). This also limits the out-rush current from the C_{OUT} capacitor into the $C_{(\text{PDIN})}$ capacitor and help protect Q1 and R_{S} .

9.1.8 Tuning OCP using R_F and C_F

In applications where there are load transients or moderate ripple on V_{OUT} , the OCP performance of TPS25740B may be impacted. Adding the R_F/C_F filter network as shown in Figure 48 helps mitigate the impact of the ripple and load transients on OCP performance.

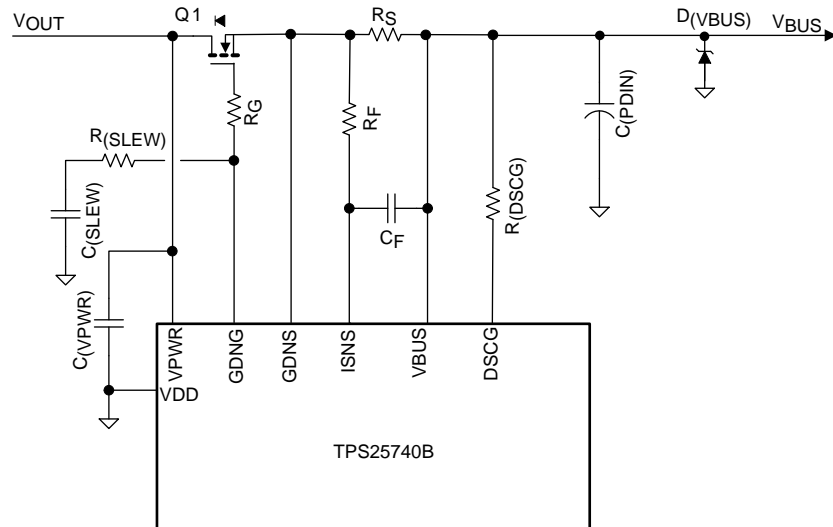

Copyright © 2016, Texas Instruments Incorporated

Figure 48. ISNS Filtering Example

R_F/C_F can be tailored to the amount of ripple on V_{OUT} as shown in Table 6.

Table 6. Ripple on V_{OUT}

FREQUENCY x RIPPLE (kHz x V)	SUGGESTED FILTER TIME CONSTANT (μ s)
< 5 (Ex: 50 mV ripple at 100 kHz)	None
5 to 15	2.2 μ s ($R_F = 10 \Omega$, $C_F = 220$ nF)
15 to 35	4.7 μ s ($R_F = 10 \Omega$, $C_F = 470$ nF)
35 to 105	10 μ s ($R_F = 10 \Omega$, $C_F = 1$ μ F)

9.2 Typical Applications

9.2.1 Typical Application, A/C Power Source (Wall Adapter)

In this design example, PSEL pin is configured so that $P_{(SEL)} = 65\text{ W}$ (see Table 7). Voltages offered are 5 V, 9 V, 15 V, and 20 V at a maximum of 3 A. The overcurrent protection (OCP) trip point is set just above 3 A and VDD on the TPS25740B is grounded. The following example is based on PMP11451 and PMP11455, see www.ti.com/tool/PMP11451. In this design, the TPS25740B and some associated discretes are located on the paddle card (PMP11455) which plugs into the power supply card (PMP11451). This allows different paddle cards with different power and voltage advertisements to be used with a common power supply design.

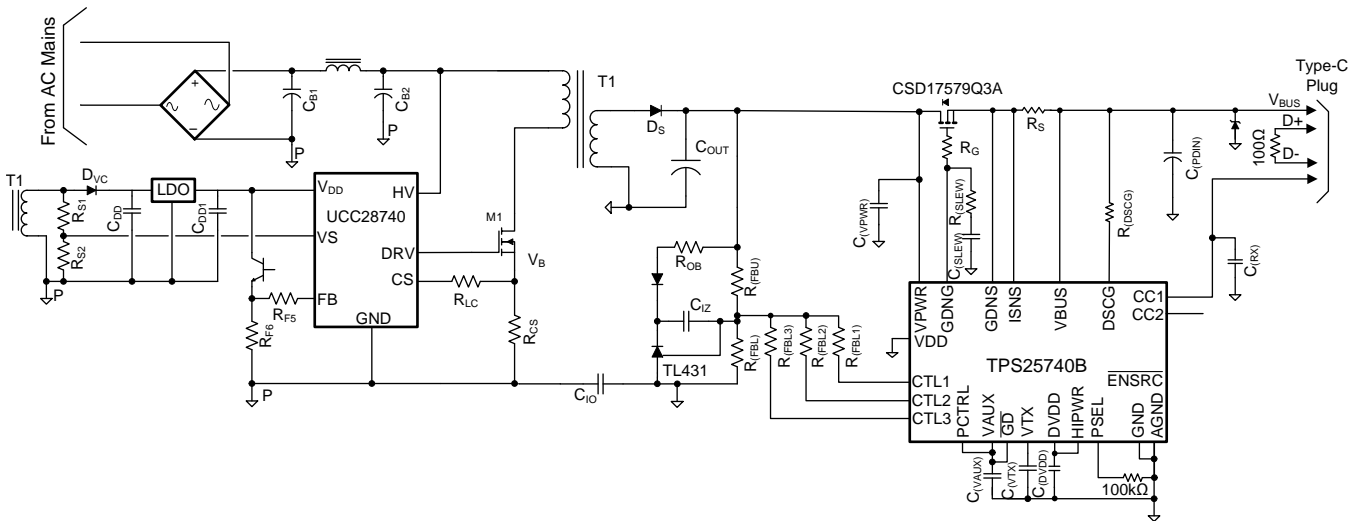

Copyright © 2016, Texas Instruments Incorporated

Figure 49. Captive Cable Adapter Provider Conceptual Schematic

9.2.1.1 Design Requirements

Table 7. Design Parameters

DESIGN PARAMETER	VALUE
Configured Power Limit, $P_{(SEL)}$	65 W
Advertised Voltages	5 V, 9V, 15V, 20 V
Advertised Current Limit	3 A
Over Current Protection Set point	4.2 A

9.2.1.2 Detailed Design Procedure

9.2.1.2.1 Power Pin Bypass Capacitors

- $C_{(VPWR)}$: 0.1 μF , 50 V, $\pm 10\%$, X7R ceramic at pin 20 (VPWR)
- $C_{(VDD)}$: 0.1 μF , 50 V, X7R ceramic at pin 17 (VDD). If VDD is not used in the application, then tie VDD to GND.
- $C_{(DVDD)}$: 0.22 μF , 10 V, $\pm 10\%$, X5R ceramic at pin 13 (DVDD)
- $C_{(VAUX)}$: 0.1 μF , 50 V, $\pm 10\%$, X7R ceramic at pin 16 (VAUX)
- $C_{(VTX)}$: 0.1 μF , 50 V, $\pm 10\%$, X7R ceramic at pin 1 (VTX)

9.2.1.2.2 Non-Configurable Components

- $R_{(SEL)}$: When the application requires advertisement using $R_{(SEL)}$, use a 100 k Ω , $\pm 1\%$ resistor.
- $R_{(PCTRL)}$: If PCTRL will be pulled low with an external device then it can be connected to VAUX using a 220 k Ω , $\pm 1\%$ resistor. If PCTRL is always high, then it can be directly connected to VAUX.
- $R_{(SLEW)}$: Use a 1 k Ω , $\pm 1\%$ resistor

- R_G : Use a 10 Ω , $\pm 1\%$ resistor

9.2.1.2.3 Configurable Components

- $C_{(RX)}$: Choose $C_{(RX)}$ between 200 pF and 600 pF. A 560 pF, 50 V, $\pm 5\%$ COG/NPO ceramic is recommended for both CC1 and CC2 pins.
- Q_1 : For a 3 A application, an N-Channel MOSFET with $R_{DS(on)}$ in the 10 m Ω range is sufficient. $BV_{(DSS)}$ should be rated for 30 V for applications delivering 20 V, and 25 V for 12 V applications. For this application, the TI CSD17579Q3A ([SLPS527](#)) NexFET™ is suitable.
- R_S : TPS25740B OCP set point thresholds are targeted towards a 5 m Ω , $\pm 1\%$ sense resistor. Power dissipation for R_S at 3 A load is approximately 45 mW.
- $R_{(DSCG)}$: The minimum value of $R_{(DSCG)}$ is chosen based on the application V_{BUS} (max) and $I_{(DSCGT)}$. For V_{BUS} (max) = 12 V and $I_{(DSCGT)} = 350$ mA, $R_{(DSCG(min))} = 34.3$ Ω . The size of the external resistor can then be chosen based on the capacitive load that needs to be discharged and the maximum allowed discharge time of 265 ms. Typically, a 120 Ω , 0.5 W resistor provides suitable performance.
- R_F/C_F : Not used
- $C_{(PDIN)}$: The requirement for $C_{(PDIN)}$ is 10 μ F maximum. A 6.8 μ F, 25 V, $\pm 10\%$ X5R or X7R ceramic capacitor is suitable for most applications.
- $D_{(VBUS)}$: $D_{(VBUS)}$ provides reverse transient protection during large transient conditions when inductive loads are present. A Schottky diode with a $V_{(RRM)}$ rating of 30 V in a SMA package such as the B340A-13-F provides suitable reverse voltage clamping performance.
- $C_{(SLEW)}$: To achieve a slew rate from zero to 5 V of less than 30 mV / μ s using the typical GDNG current of 20 μ A then $C_{(SLEW)} > 20$ μ A / 30 mV / μ s = 0.67 nF be used. Choosing $C_{(SLEW)} = 10$ nF yields a ramp rate of 2 mV / μ s.
- $R_{(FBL1)}/R_{(FBL2)}/R_{(FBL3)}$: In this design example, $R_{(FBU)} = 20$ k Ω and $R_{(FBL)} = 20$ k Ω . The feedback error amplifier is TL431AI which is rated for up to 36 V operation and $V_{REF} = 2.495$ V. Using the equation for $R_{(FBL2)}$ above yields a calculated value of 12.44 k Ω and a selected value of 12.4 k Ω . In similar fashion for $R_{(FBL1)}$, the equation yields a calculated value of 8.34 k Ω and a selected value of 8.25 k Ω . Lastly for $R_{(FBL3)}$, the calculated value is 10.1 k Ω with a selected value of 10 k Ω .

9.2.1.3 Application Curves

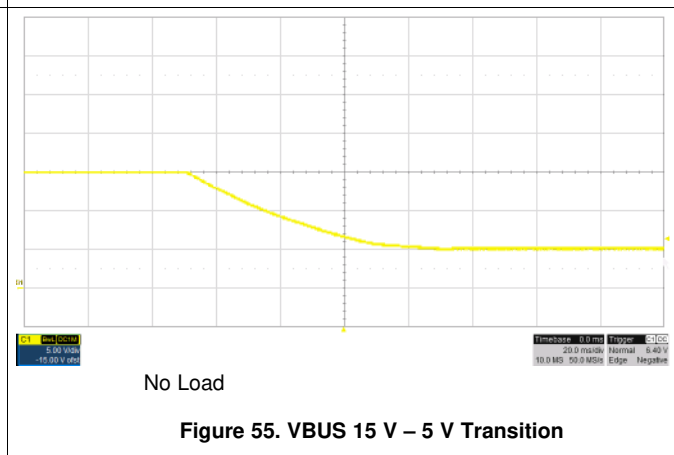
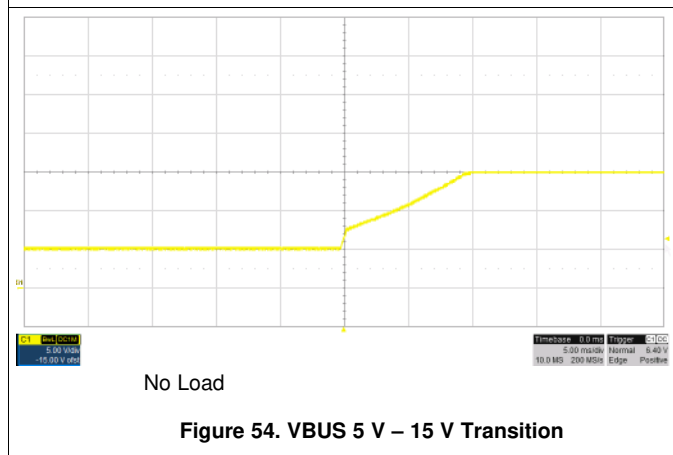
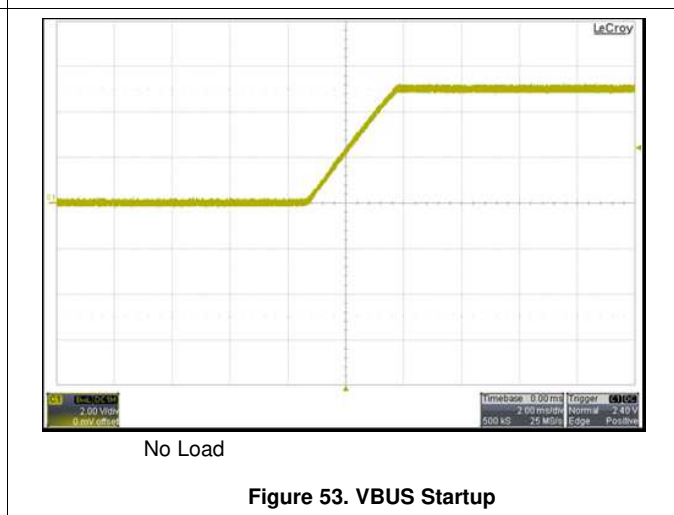
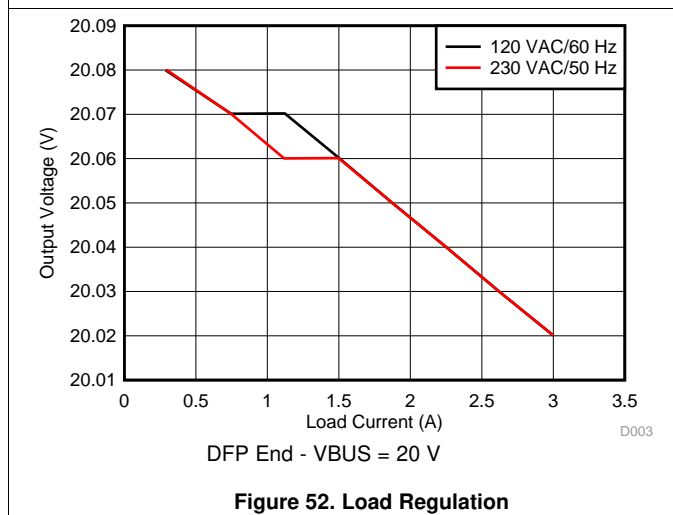
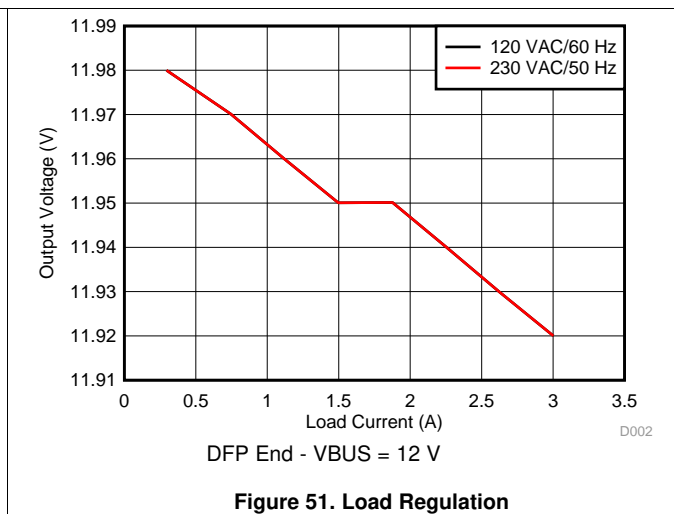
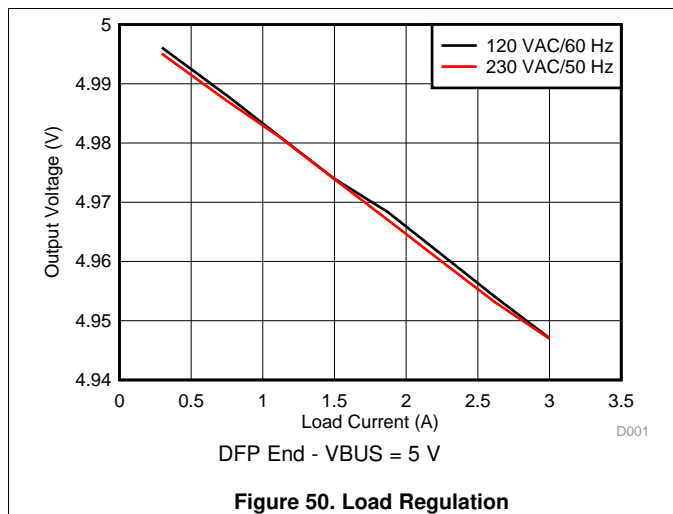

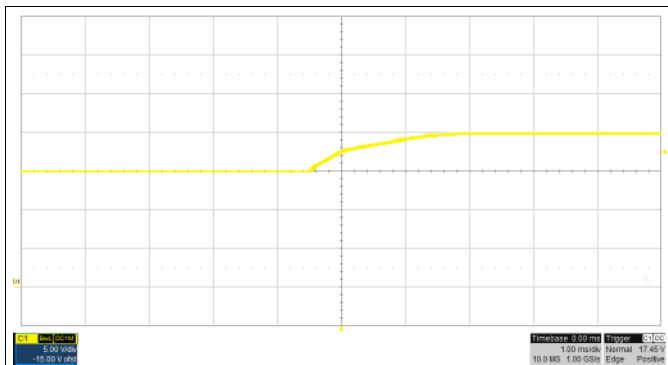

No Load

Figure 56. VBUS 15 V – 20 V Transition

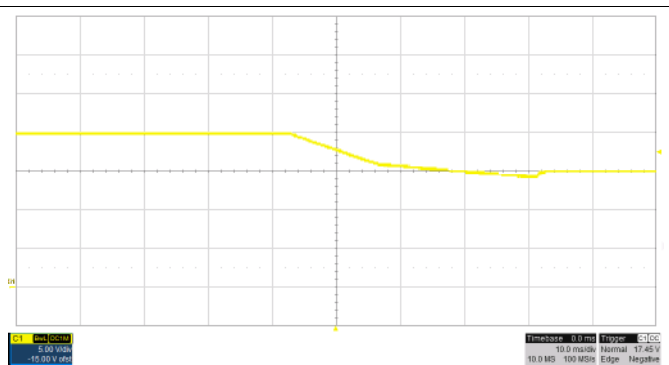

No Load

Figure 57. VBUS 20 V – 15 V Transition

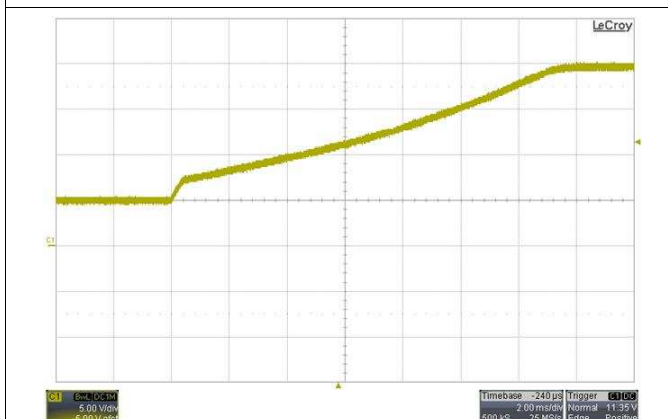

No Load

Figure 58. VBUS 5 V – 20 V Transition

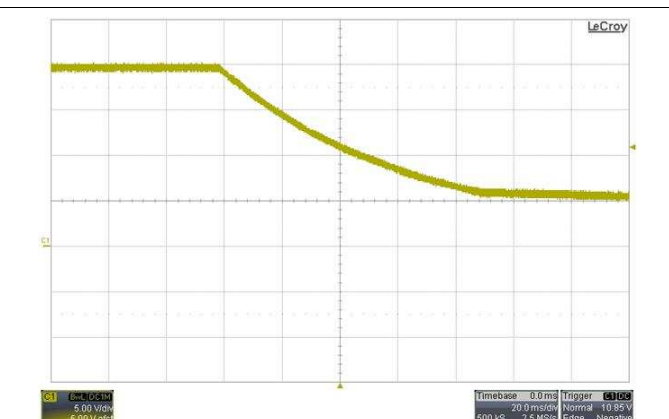

No Load

Figure 59. VBUS 20 V – 5 V Transition

9.2.2 Typical Application, D/C Power Source

In this design example the PSEL pin is configured such that $P_{(SEL)} = 65\text{ W}$ (see Table 8). Voltages offered are 5 V, 9 V, 15 V, and 20 V at a maximum of 3 A. The overcurrent protection (OCP) trip point is set just above 3 A and VDD on the TPS25740B is grounded. The following example is based on TPS25740BEVM-741 (refer to Documentation Support).

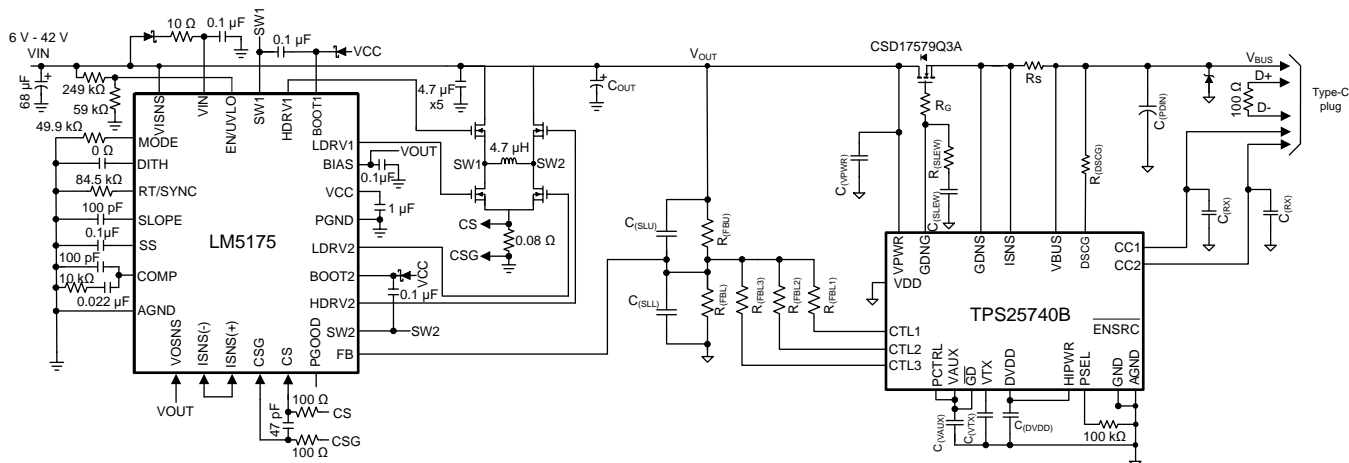

Copyright © 2016, Texas Instruments Incorporated

Figure 60. DC Power Source

9.2.2.1 Design Requirements

Table 8. Design Parameters

DESIGN PARAMETER	VALUE
Configured Power Limit, $P_{(SEL)}$	65 W
Advertised Voltages	5 V, 9 V, 15 V, 20 V
Advertised Current Limit	3 A
Over Current Protection Set point	4.2 A

9.2.2.2 Detailed Design Procedure

9.2.2.2.1 Power Pin Bypass Capacitors

- $C_{(VPWR)}$: 0.1 μF , 50 V, $\pm 10\%$, X7R ceramic at pin 20 (VPWR)
- $C_{(VDD)}$: 0.1 μF , 50 V, X7R ceramic at pin 17 (VDD). If VDD is not used in the application, then tie VDD to GND.
- $C_{(DVDD)}$: 0.22 μF , 10 V, $\pm 10\%$, X5R ceramic at pin 13 (DVDD)
- $C_{(VAUX)}$: 0.1 μF , 50 V, $\pm 10\%$, X7R ceramic at pin 16 (VAUX)
- $C_{(VTX)}$: 0.1 μF , 50 V, $\pm 10\%$, X7R ceramic at pin 1 (VTX)

9.2.2.2.2 Non-Configurable Components

- $R_{(SEL)}$: When the application requires advertisement using $R_{(SEL)}$, use a 100 k Ω , $\pm 1\%$ resistor.
- $R_{(PCTRL)}$: If PCTRL will be pulled low with an external device then it can be connected to VAUX using a 220 k Ω , $\pm 1\%$ resistor. If PCTRL will always be high then it can be directly connected to VAUX.
- $R_{(SLEW)}$: Use a 1 k Ω , $\pm 1\%$ resistor
- R_G : Use a 10 Ω , $\pm 1\%$ resistor

9.2.2.2.3 Configurable Components

- $C_{(RX)}$: Choose $C_{(RX)}$ between 200 pF and 600 pF. A 560 pF, 50 V, $\pm 5\%$ COG/NPO ceramic is recommended for both CC1 and CC2 pins.
- Q_1 : For a 3 A application, an N-Channel MOSFET with $R_{DS(on)}$ in the 10 m Ω range is sufficient. $BV_{(DSS)}$ should be rated for 30 V for applications delivering 20 V, and 25 V for 15 V applications. For this application, the TI CSD17579Q3A (SLPS527) NexFET™ is suitable.
- R_S : TPS25740B OCP set point thresholds are targeted towards a 5 m Ω , $\pm 1\%$ sense resistor. Power dissipation for R_S at 3 A load is approximately 45 mW.
- $R_{(DSCG)}$: The minimum value of $R_{(DSCG)}$ is chosen based on the application VBUS (max) and $I_{(DSCGT)}$. For VBUS (max) = 15 V and $I_{(DSCGT)} = 350$ mA, $R_{DS(CG(min))} = 42.9 \Omega$. The size of the external resistor can then be chosen based on the capacitive load that needs to be discharged and the maximum allowed discharge time of 265 ms. Typically, a 120 Ω , 0.5 W resistor provides suitable performance.
- R_F/C_F : Not used
- $C_{(PDIN)}$: The requirement for $C_{(PDIN)}$ is 10 μ F maximum. A 6.8 μ F, 25 V, $\pm 10\%$ X5R or X7R ceramic capacitor is suitable for most applications.
- $D_{(VBUS)}$: $D_{(VBUS)}$ provides reverse transient protection during large transient conditions when inductive loads are present. A Schottky diode with a $V_{(RRM)}$ rating of 30 V in a SMA package such as the B340A-13-F provides suitable reverse voltage clamping performance.
- $C_{(SLEW)}$: To achieve a slew rate from zero to 5 V of less than 30 mV / μ s using the typical GDNG current of 20 μ A then $C_{(SLEW)} (nF) > 20 \mu A / 30 mV / \mu s = 0.67 nF$ be used. Choosing $C_{(SLEW)} = 10$ nF yields a ramp rate of 2 mV / μ s.
- $R_{(FBL1)}/R_{(FBL2)}/R_{(FBL3)}$: In this design example, $R_{(FBU)} = 49.9$ k Ω and $R_{(FBL)} = 9.53$ k Ω . The feedback error amplifier $V_{REF} = 0.8$ V. Using the equations for $R_{(FBL2)}$ (Equation 5 and Equation 6) provide a calculated value of 9.9 k Ω and a selected value of 9.76 k Ω . In similar fashion for $R_{(FBL1)}$, a calculated value of 6.74 k Ω and a selected value of 6.65 k Ω is provided. Lastly for $R_{(FBL3)}$, the calculated value is 8.1 k Ω with a selected value of 8.06 k Ω .
- $C_{(SLU)}/C_{(SLL)}$: The value of $C_{(SLU)}$ is calculated based on the desired 95% slew rate using Equation 13 and Equation 14. Choose a 22 nF capacitor for $C_{(SLU)}$. Choose a 100 nF capacitor for $C_{(SLL)}$.

9.2.2.3 Application Curves

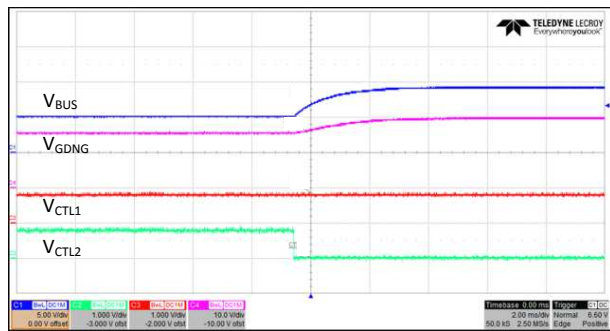

No Load

Figure 61. VBUS 5 V – 9 V Transition

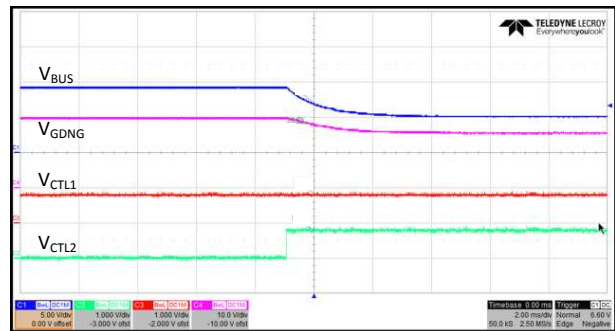

No Load

Figure 62. VBUS 9 V – 5 V Transition

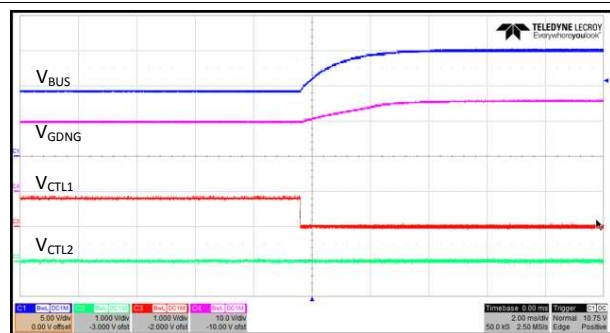

No Load

Figure 63. VBUS 9 V – 15 V Transition

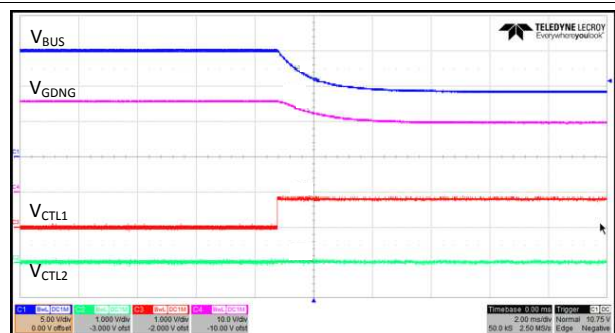

No Load

Figure 64. VBUS 15 V – 9 V Transition

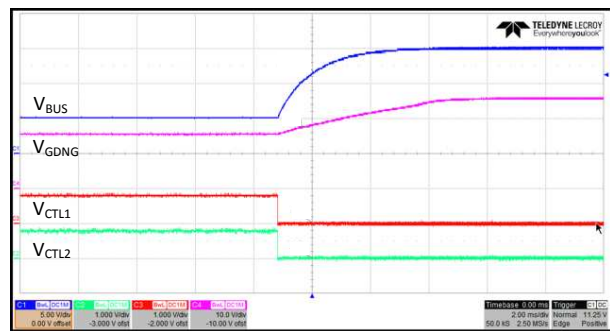

No Load

Figure 65. VBUS 5 V – 15 V Transition

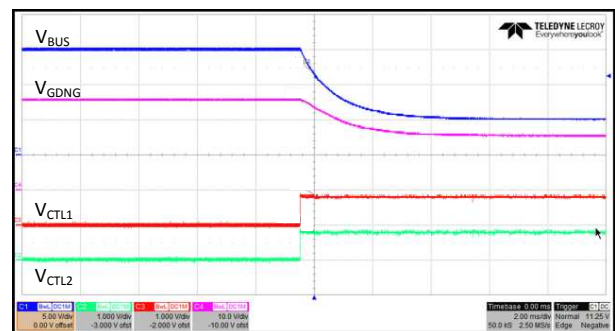

No Load

Figure 66. VBUS 15 V – 5 V Transition

9.3 System Examples

9.3.1 D/C Power Source (Power Hub)

In this system design example, the $P_{(SEL)}$ is configured such that $P_{(SEL)} = 93\text{ W}$, so 5 V, 9 V, and 15 V are offered at a maximum of 5 A, while 20 V is offered at a maximum of 4.64 A. The over-current protection (OCP) trip point is set just above 5 A.

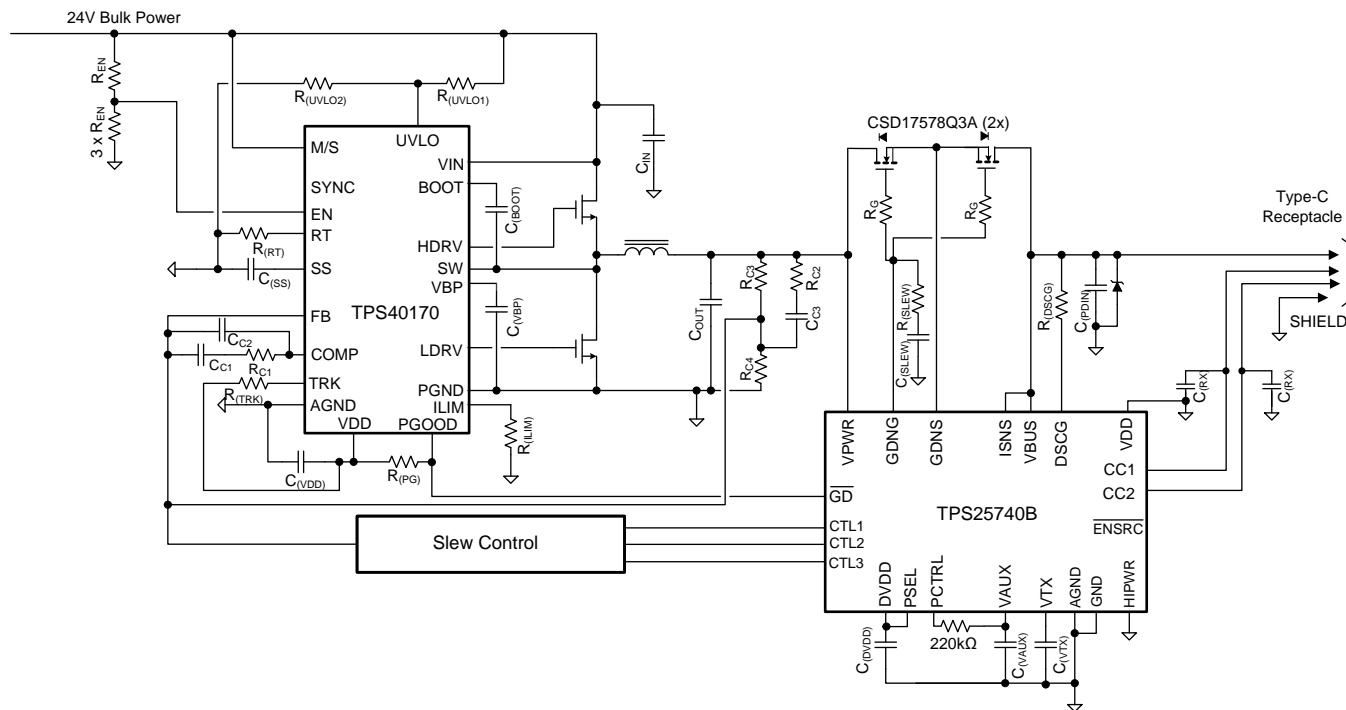

Copyright © 2016, Texas Instruments Incorporated

Figure 67. Power Hub Concept (Provider only)

This power hub circuit takes a 24 V input and produces a regulated output voltage. The over-current protection feature in the TPS25740B is not used; the ISNS and VBUS pins are connected directly. Instead $R_{(ILIM)}$ is chosen to set the current limit of the TPS40170 synchronous PWM buck controller. If the current limit trips, the \overline{GD} pin of the TPS25740B is pulled low by the PGOOD pin of the TPS40170, which causes the power-path switch to be opened. Other fault conditions may also pull PGOOD low, but the slew rate of the voltage transition should be controlled as in one of the examples given above (Figure 44, Figure 45, or Figure 47).

VDD on the TPS25740B is grounded, if there is a suitable power supply available in the system the TPS25740B operates more efficiently if it is connected to VDD since $V_{(VPWR)} > V_{(VDD)}$. See Figure 70 for an example.

System Examples (continued)

9.3.2 A/C Power Source (Wall Adapter)

In this system design example, the PSEL pin is configured such that $P_{(SEL)} = 36\text{ W}$, and 5 V, 9 V are offered at a maximum of 3 A while 15 V is offered at a maximum of 2.4 A and 20 V is offered at a maximum of 1.8A. The overcurrent protection (OCP) trip point is set just above 3 A. VDD on the TPS25740B is grounded, if there is a suitable power supply available in the system the TPS25740B operates more efficiently if it is connected to VDD since $V_{(VPWR)} > V_{(VDD)}$.

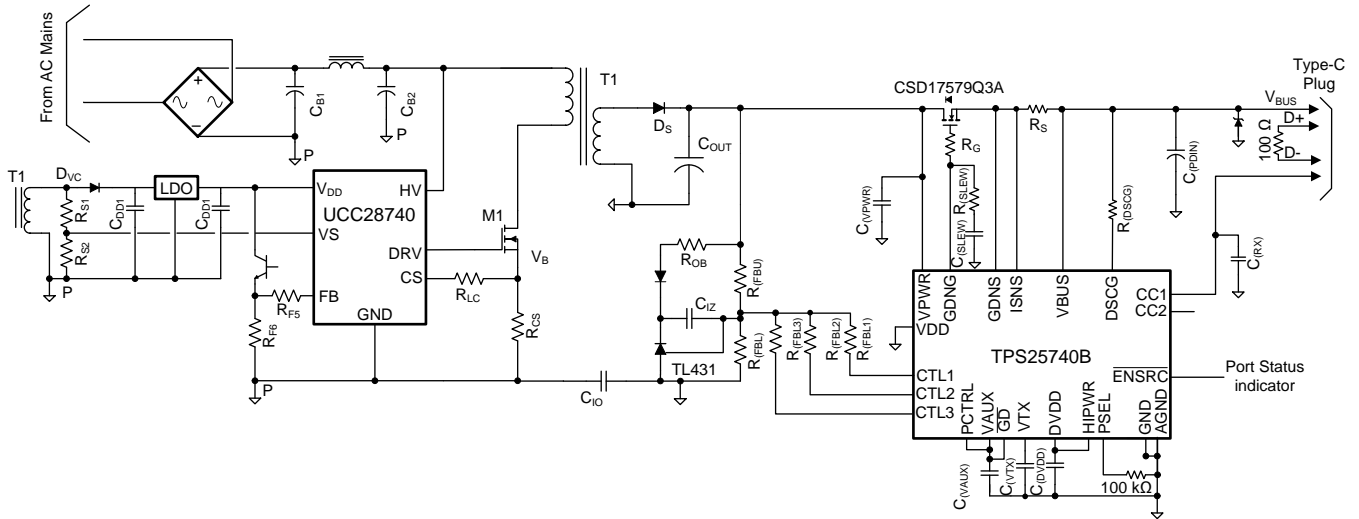

Copyright © 2016, Texas Instruments Incorporated

Figure 68. Adapter Provider Concept

System Examples (continued)

9.3.3 Dual-Port A/C Power Source (Wall Adaptor)

In this system design example, the PSEL pin is configured such that $P_{(SEL)} = 36\text{ W}$, and 5 V, 9 V, 12 V are offered at a maximum of 3 A while 15 V is offered at a maximum of 2.4A. The over-current protection (OCP) trip point is set just above 3 A.

The $\overline{\text{ENSRC}}$ pin from one TPS25740B is attached to the PCTRL pin on the other TPS25740B. When one port is not active (no UFP attached through the receptacle) its $\overline{\text{ENSRC}}$ pin is left high-z so the PCTRL pin on the other port is pulled high. This allows the adaptor to provide up to the full 36 W on a single port if a single UFP is attached. If two UFP's are attached (one to each port) then each port only offers current that would reach a maximum of 18 W. So each port is allocated half of the overall power when each port has a UFP attached.

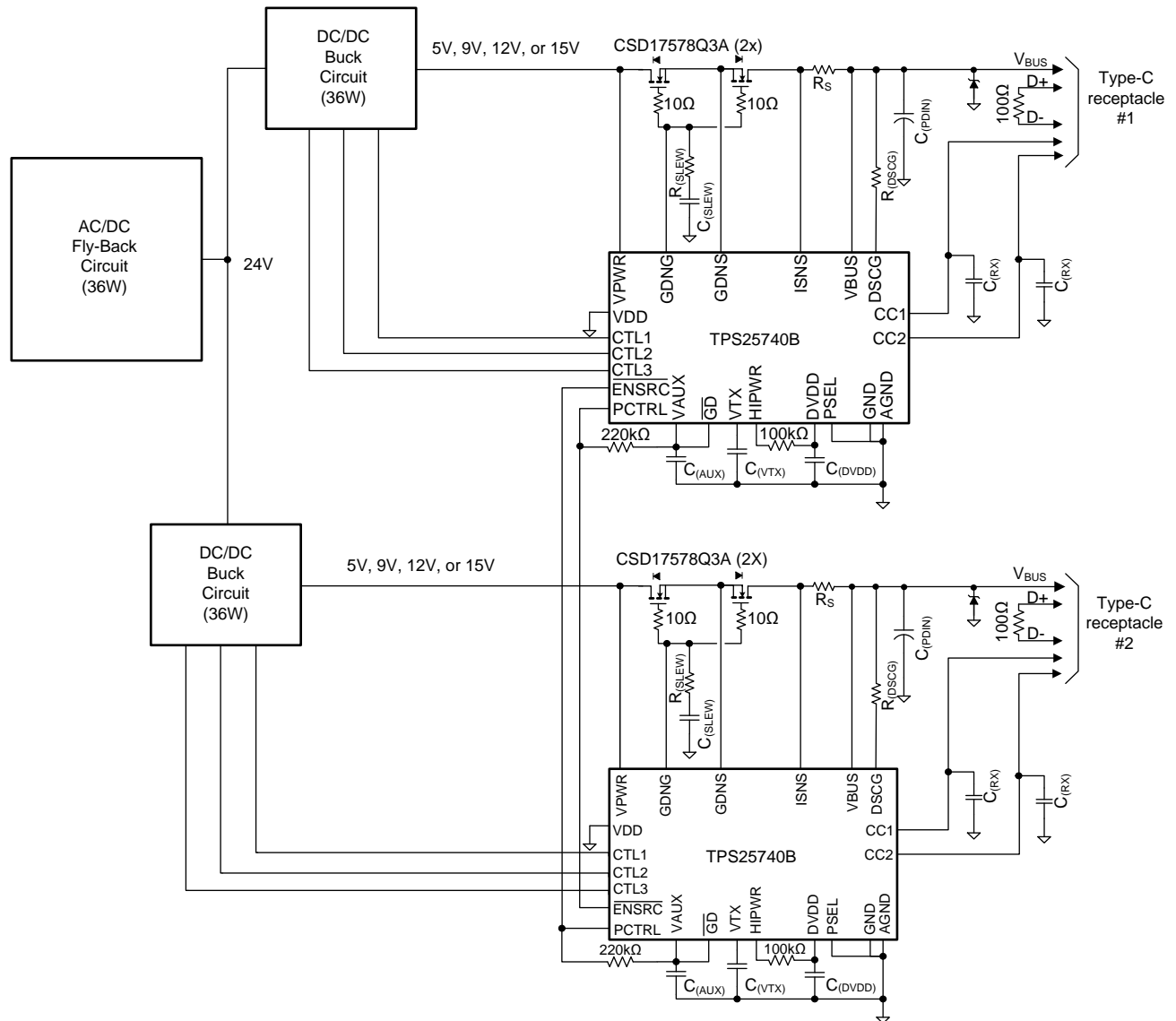

Copyright © 2016, Texas Instruments Incorporated

Figure 69. Dual-Port Adapter Provider Concept

System Examples (continued)

9.3.4 D/C Power Source (Power Hub with 3.3 V Rail)

In [Figure 70](#), an LDO that outputs at least $I_{(SUPP)}$ at 3.3 V or 5 V is added to the power hub concept, and the DVDD pin is used to enable the buck regulator since it is active high. This implementation is more power efficient than the one in [Figure 67](#).

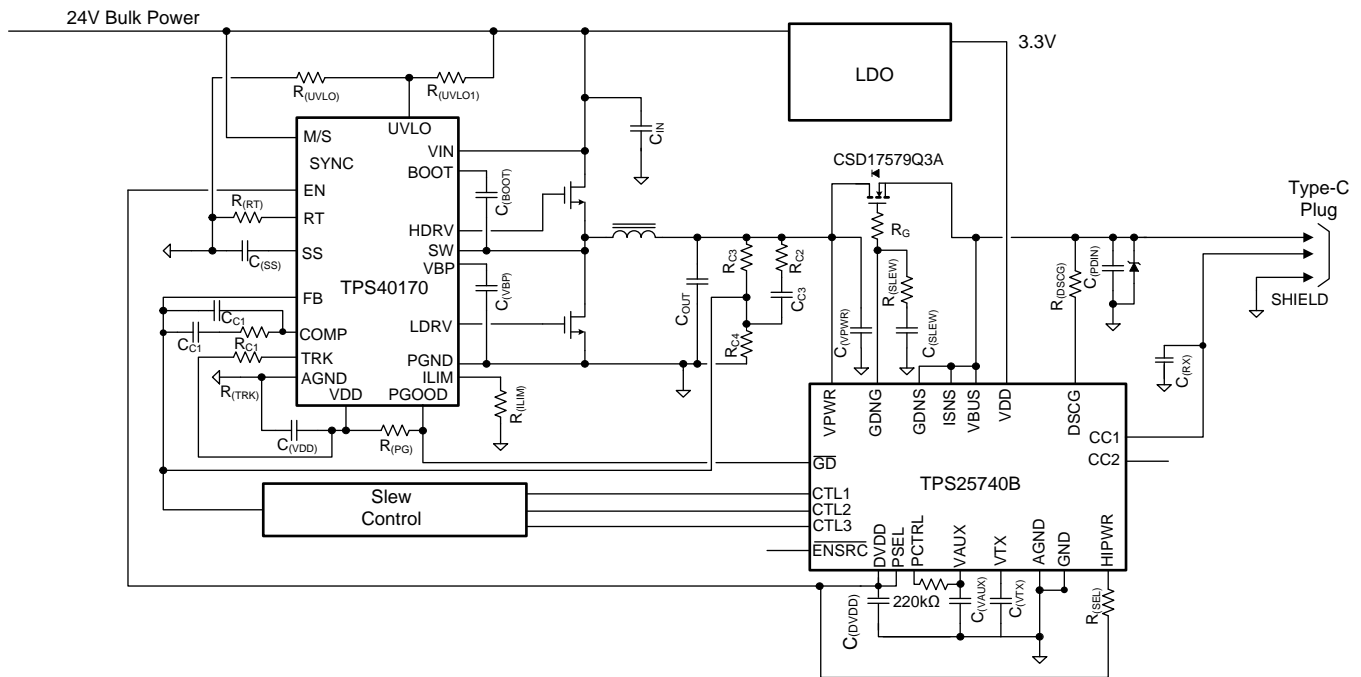

Copyright © 2016, Texas Instruments Incorporated

Figure 70. Power Hub Concept (Provider only)

10 Power Supply Recommendations

10.1 VDD

The recommended VDD supply voltage range is 3 V to 5.5 V. The device requires approximately 2 mA ($I_{(SUPP)}$) typical in normal operating mode and below 10 μ A in sleep mode. If the VDD supply is not used, then it may be connected to AGND/GND.

10.2 VPWR

The recommended VPWR supply voltage range is 0 V to 25 V. The device requires approximately 2 mA ($I_{(SUPP)}$) typical in normal operating mode and below 10 μ A in sleep mode.

11 Layout

11.1 Port Current Kelvin Sensing

Figure 71 provides a routing example for accurate current sensing for the overcurrent protection feature. The sense amplifier measurement occurs between the ISNS and VBUS pins of the device. Improper connection of these pins can result in poor OCP performance.

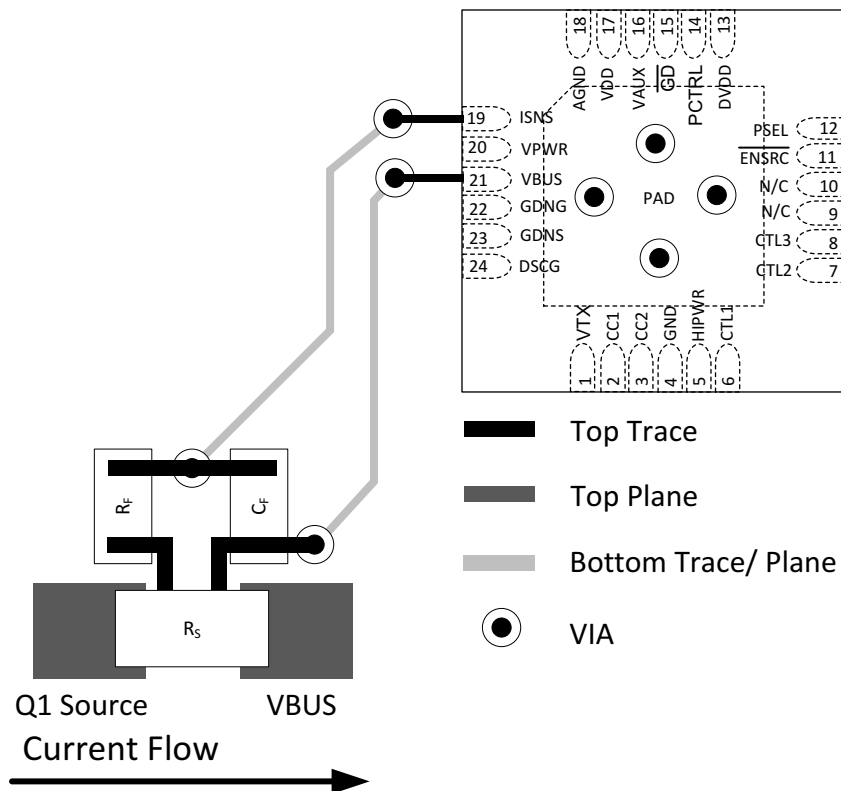

Figure 71. Kelvin Sense Layout Example

11.2 Layout Guidelines

11.2.1 Power Pin Bypass Capacitors

- $C_{(VPWR)}$: Place close to pin 20 (VPWR) and connect with low inductance traces and vias according to Figure 72.
- $C_{(VDD)}$: Place close to pin 17 (VDD) and connect with low inductance traces and vias according to Figure 72.
- $C_{(DVDD)}$: Place close to pin 13 (DVDD) and connect with low inductance traces and vias according to Figure 72.
- $C_{(VAUX)}$: Place close to pin 16 (VAUX) and connect with low inductance traces and vias according to Figure 72.
- $C_{(VTX)}$: Place close to pin 1 (VTX) and connect with low inductance traces and vias according to Figure 72.

11.2.2 Supporting Components

- $C_{(RX)}$: Place $C_{(RX1)}$ and $C_{(RX2)}$ in line with the CC1 and CC2 traces as shown in Figure 25. These should be placed within one inch from the Type C connector. Minimize stubs and tees from on the trace routes.
- Q_1 : Place Q_1 in a manner such that power flows uninterrupted from Q_1 drain to the Type C connector VBUS connections. Provide adequate copper plane from Q_1 drain and source to the interconnecting circuits.
- R_S : Place R_S as shown in Figure 72 to facilitate uninterrupted power flow to the Type C connector. Orient R_S for optimal Kelvin sense connection/routing back to the TPS25740B. In high current applications where the

12 Device and Documentation Support

12.1 Documentation Support

USB PD and USB Type-C specifications available at: <http://www.usb.org/home>

[TPS25740BEVM-741 EVM User's Guide](#)

[TPS25740B Design Calculator Tool](#)

12.2 Receiving Notification of Documentation Updates

To receive notification of documentation updates, navigate to the device product folder on ti.com. In the upper right corner, click on *Alert me* to register and receive a weekly digest of any product information that has changed. For change details, review the revision history included in any revised document.

12.3 Community Resources

The following links connect to TI community resources. Linked contents are provided "AS IS" by the respective contributors. They do not constitute TI specifications and do not necessarily reflect TI's views; see TI's [Terms of Use](#).

TI E2E™ Online Community *TI's Engineer-to-Engineer (E2E) Community*. Created to foster collaboration among engineers. At e2e.ti.com, you can ask questions, share knowledge, explore ideas and help solve problems with fellow engineers.

Design Support *TI's Design Support* Quickly find helpful E2E forums along with design support tools and contact information for technical support.

12.4 Trademarks

E2E is a trademark of Texas Instruments.
Type-C is a trademark of USB Implementers Forum.

12.5 Electrostatic Discharge Caution



These devices have limited built-in ESD protection. The leads should be shorted together or the device placed in conductive foam during storage or handling to prevent electrostatic damage to the MOS gates.

12.6 Glossary

[SLYZ022](#) — *TI Glossary*.

This glossary lists and explains terms, acronyms, and definitions.

13 Mechanical, Packaging, and Orderable Information

The following pages include mechanical, packaging, and orderable information. This information is the most current data available for the designated devices. This data is subject to change without notice and revision of this document. For browser-based versions of this data sheet, refer to the left-hand navigation.

PACKAGING INFORMATION

Orderable Device	Status (1)	Package Type	Package Drawing	Pins	Package Qty	Eco Plan (2)	Lead finish/ Ball material (6)	MSL Peak Temp (3)	Op Temp (°C)	Device Marking (4/5)	Samples
TPS25740BRGER	NRND	VQFN	RGE	24	3000	RoHS & Green	NIPDAU	Level-1-260C-UNLIM	-40 to 125	TPS 25740B	
TPS25740BRGET	NRND	VQFN	RGE	24	250	RoHS & Green	NIPDAU	Level-1-260C-UNLIM	-40 to 125	TPS 25740B	

(1) The marketing status values are defined as follows:

ACTIVE: Product device recommended for new designs.

LIFEBUY: TI has announced that the device will be discontinued, and a lifetime-buy period is in effect.

NRND: Not recommended for new designs. Device is in production to support existing customers, but TI does not recommend using this part in a new design.

PREVIEW: Device has been announced but is not in production. Samples may or may not be available.

OBSOLETE: TI has discontinued the production of the device.

(2) **RoHS:** TI defines "RoHS" to mean semiconductor products that are compliant with the current EU RoHS requirements for all 10 RoHS substances, including the requirement that RoHS substance do not exceed 0.1% by weight in homogeneous materials. Where designed to be soldered at high temperatures, "RoHS" products are suitable for use in specified lead-free processes. TI may reference these types of products as "Pb-Free".

RoHS Exempt: TI defines "RoHS Exempt" to mean products that contain lead but are compliant with EU RoHS pursuant to a specific EU RoHS exemption.

Green: TI defines "Green" to mean the content of Chlorine (Cl) and Bromine (Br) based flame retardants meet JS709B low halogen requirements of <=1000ppm threshold. Antimony trioxide based flame retardants must also meet the <=1000ppm threshold requirement.

(3) MSL, Peak Temp. - The Moisture Sensitivity Level rating according to the JEDEC industry standard classifications, and peak solder temperature.

(4) There may be additional marking, which relates to the logo, the lot trace code information, or the environmental category on the device.

(5) Multiple Device Markings will be inside parentheses. Only one Device Marking contained in parentheses and separated by a "~" will appear on a device. If a line is indented then it is a continuation of the previous line and the two combined represent the entire Device Marking for that device.

(6) Lead finish/Ball material - Orderable Devices may have multiple material finish options. Finish options are separated by a vertical ruled line. Lead finish/Ball material values may wrap to two lines if the finish value exceeds the maximum column width.

Important Information and Disclaimer: The information provided on this page represents TI's knowledge and belief as of the date that it is provided. TI bases its knowledge and belief on information provided by third parties, and makes no representation or warranty as to the accuracy of such information. Efforts are underway to better integrate information from third parties. TI has taken and continues to take reasonable steps to provide representative and accurate information but may not have conducted destructive testing or chemical analysis on incoming materials and chemicals. TI and TI suppliers consider certain information to be proprietary, and thus CAS numbers and other limited information may not be available for release.

In no event shall TI's liability arising out of such information exceed the total purchase price of the TI part(s) at issue in this document sold by TI to Customer on an annual basis.

TAPE AND REEL INFORMATION



QUADRANT ASSIGNMENTS FOR PIN 1 ORIENTATION IN TAPE



*All dimensions are nominal

Device	Package Type	Package Drawing	Pins	SPQ	Reel Diameter (mm)	Reel Width W1 (mm)	A0 (mm)	B0 (mm)	K0 (mm)	P1 (mm)	W (mm)	Pin1 Quadrant
TPS25740BRGER	VQFN	RGE	24	3000	330.0	12.4	4.25	4.25	1.15	8.0	12.0	Q2
TPS25740BRGET	VQFN	RGE	24	250	180.0	12.4	4.25	4.25	1.15	8.0	12.0	Q2

TAPE AND REEL BOX DIMENSIONS

*All dimensions are nominal

Device	Package Type	Package Drawing	Pins	SPQ	Length (mm)	Width (mm)	Height (mm)
TPS25740BRGER	VQFN	RGE	24	3000	367.0	367.0	35.0
TPS25740BRGET	VQFN	RGE	24	250	210.0	185.0	35.0

RGE 24

GENERIC PACKAGE VIEW

VQFN - 1 mm max height

PLASTIC QUAD FLATPACK - NO LEAD

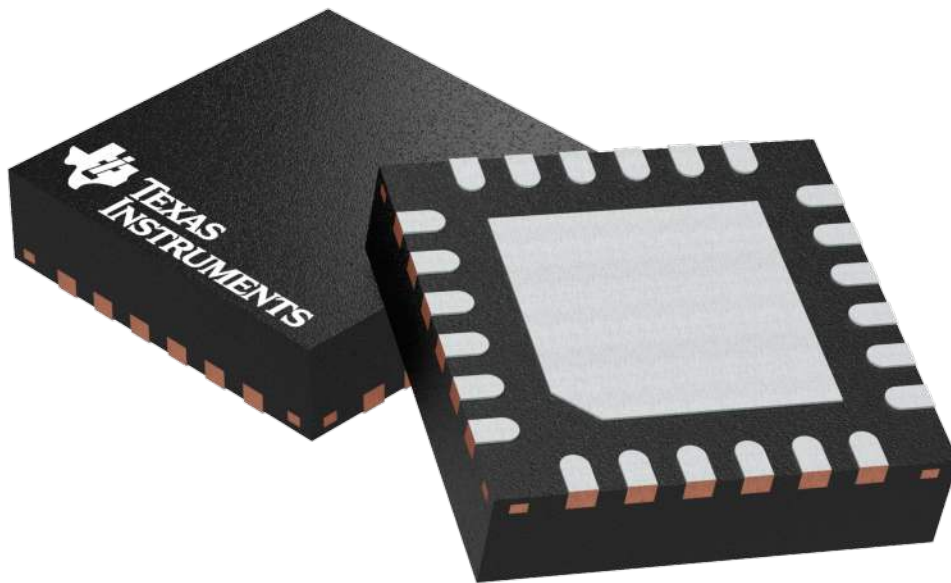

Images above are just a representation of the package family, actual package may vary.
Refer to the product data sheet for package details.

4204104/H

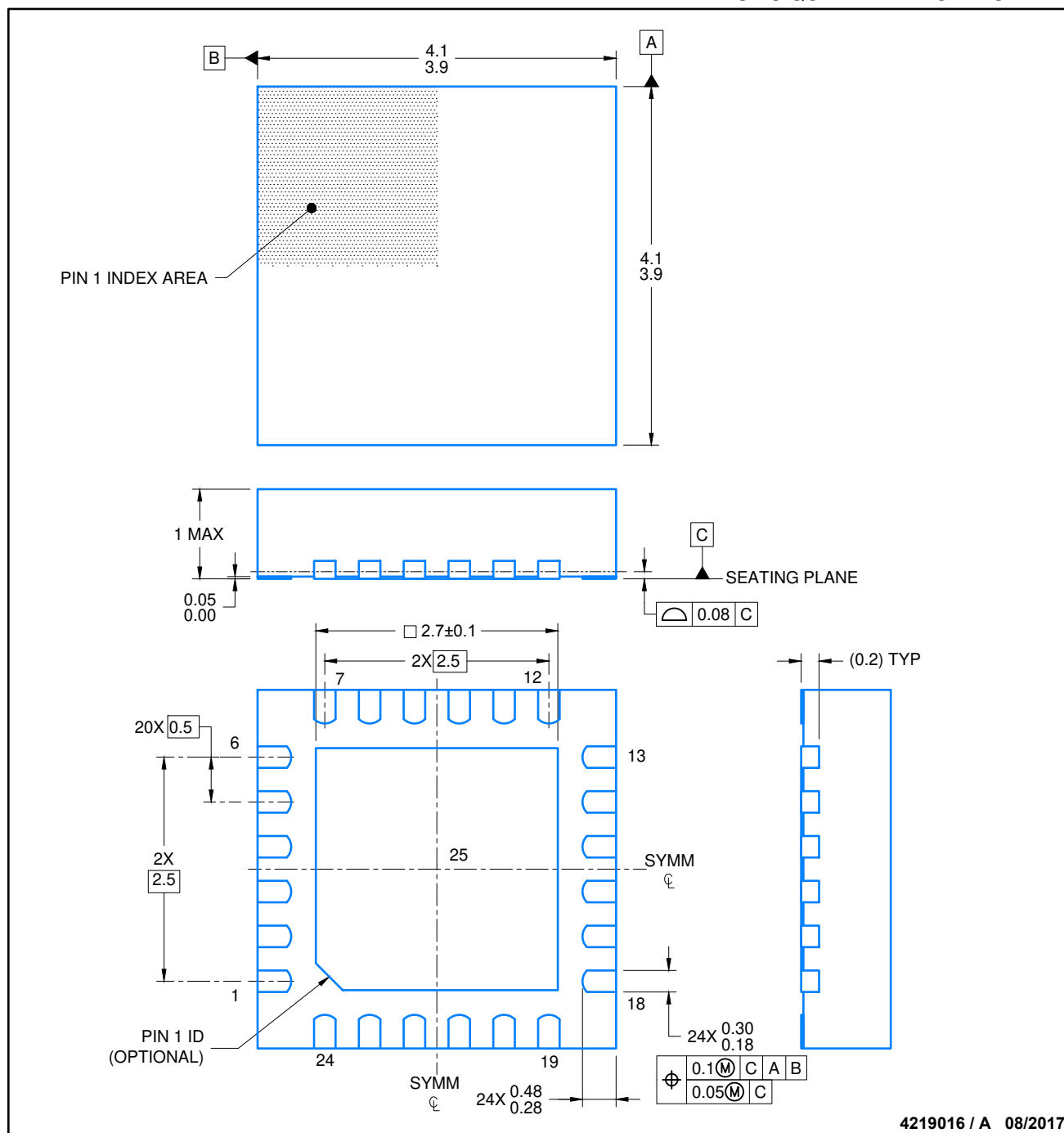

NOTES:

1. All linear dimensions are in millimeters. Any dimensions in parenthesis are for reference only. Dimensioning and tolerancing per ASME Y14.5M.
2. This drawing is subject to change without notice.
3. The package thermal pad must be soldered to the printed circuit board for thermal and mechanical performance.

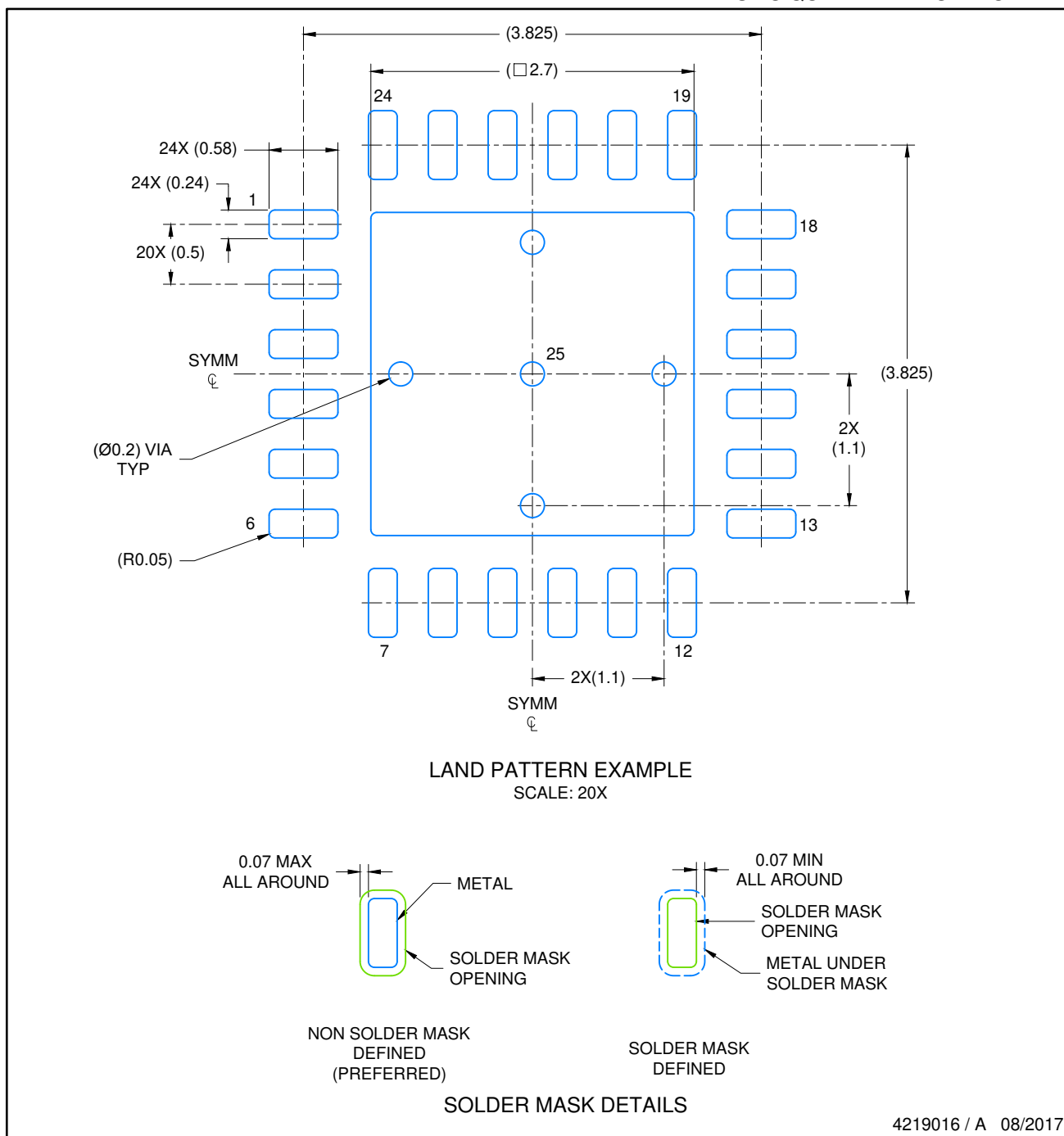

NOTES: (continued)

4. This package is designed to be soldered to a thermal pad on the board. For more information, see Texas Instruments literature number SLUA271 (www.ti.com/lit/slua271).
5. Solder mask tolerances between and around signal pads can vary based on board fabrication site.

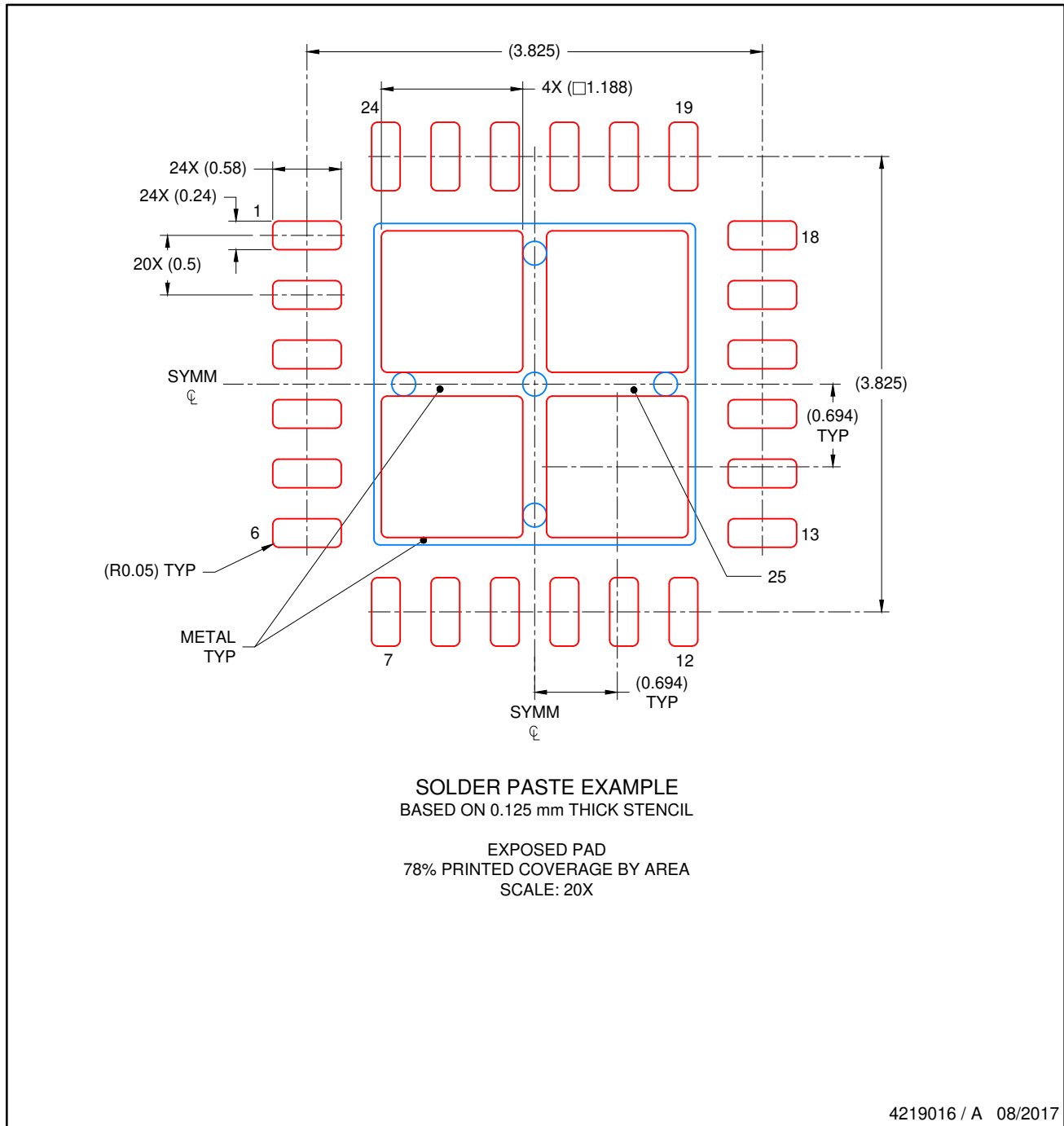

NOTES: (continued)

6. Laser cutting apertures with trapezoidal walls and rounded corners may offer better paste release. IPC-7525 may have alternate design recommendations..

IMPORTANT NOTICE AND DISCLAIMER

TI PROVIDES TECHNICAL AND RELIABILITY DATA (INCLUDING DATASHEETS), DESIGN RESOURCES (INCLUDING REFERENCE DESIGNS), APPLICATION OR OTHER DESIGN ADVICE, WEB TOOLS, SAFETY INFORMATION, AND OTHER RESOURCES "AS IS" AND WITH ALL FAULTS, AND DISCLAIMS ALL WARRANTIES, EXPRESS AND IMPLIED, INCLUDING WITHOUT LIMITATION ANY IMPLIED WARRANTIES OF MERCHANTABILITY, FITNESS FOR A PARTICULAR PURPOSE OR NON-INFRINGEMENT OF THIRD PARTY INTELLECTUAL PROPERTY RIGHTS.

These resources are intended for skilled developers designing with TI products. You are solely responsible for (1) selecting the appropriate TI products for your application, (2) designing, validating and testing your application, and (3) ensuring your application meets applicable standards, and any other safety, security, or other requirements. These resources are subject to change without notice. TI grants you permission to use these resources only for development of an application that uses the TI products described in the resource. Other reproduction and display of these resources is prohibited. No license is granted to any other TI intellectual property right or to any third party intellectual property right. TI disclaims responsibility for, and you will fully indemnify TI and its representatives against, any claims, damages, costs, losses, and liabilities arising out of your use of these resources.

TI's products are provided subject to TI's Terms of Sale (<https://www.ti.com/legal/termsofsale.html>) or other applicable terms available either on [ti.com](https://www.ti.com) or provided in conjunction with such TI products. TI's provision of these resources does not expand or otherwise alter TI's applicable warranties or warranty disclaimers for TI products.

Mailing Address: Texas Instruments, Post Office Box 655303, Dallas, Texas 75265
Copyright © 2021, Texas Instruments Incorporated