

DATE CODE LOCATION
SEE NOTE 7

NOTES:

1. MATERIAL:

CAGE: NICKEL SILVER, THICKNESS: 0.25mm
 CONNECTOR HOUSING: GLASS FILLED LIQUID CRYSTAL POLYMER (LCP), UL 94V-0,
 COLOR: BLACK
 OVERMOLD TERMINAL HOUSING: GLASS FILLED LIQUID CRYSTAL POLYMER (LCP),
 UL 94V-0, COLOR: BLACK
 TERMINALS: TIN BRASS

2. FINISHES:

TERMINALS: CONTACT AREA: 0.76 MICROMETERS MINIMUM HARD GOLD
 OVER 1.27 MICROMETERS MINIMUM NICKEL.
 COMPLIANT TAIL - MATTE TIN/LEAD OPTION: 0.76 TO 1.52 MICROMETERS
 90/10 MATTE TIN-LEAD OVER 0.76 MICROMETERS MINIMUM NICKEL.
 COMPLIANT TAIL - MATTE TIN OPTION: 0.76 TO 1.52 MICROMETERS
 MATTE TIN OVER 0.76 MICROMETERS MINIMUM NICKEL.

3. REFER TO PS-75310-001 FOR ALL ELECTRICAL,

MECHANICAL AND ENVIRONMENTAL SPECIFICATIONS.

4. REFER TO PK-75462-001 FOR ALL PACKAGING SPECIFICATIONS.

5. THE CURVED TAILS THAT GO INTO THE HOLES LOCATED BY THESE DIMENSIONS
 ARE BEING ELIMINATED. TO ACCOMMODATE THIS CONVERSION, IT IS RECOMMENDED
 THAT BOARDS DESIGNED TO THIS PRINT REVISION INCLUDE THESE HOLES.

6. THE SURFACES CONFORM TO THE MOLEX COSMETIC SPEC PS-45499-002.

ALL EXTERIOR SURFACES TO BE CLASS "B" SURFACE EXCEPT THE
 UNDERSIDE (CLASS "C") OF THE CAGE (SIDE TOWARD THE PCB) AND
 AS OTHERWISE NOTED.

7. DATE CODE LOCATION IS SHOWN ABOVE.

DATE CODE FORMAT: DDDY MX A1

DDD = DAY OF THE YEAR

Y = YEAR

MX = MOLEX

A = ALPHA CHARACTER - INDICATES MANUFACTURING LINE

1 = NUMERIC CHARACTER - INDICATES PRODUCTION SHIFT

PART NUMBER	COMPLIANT TAIL PLATING
754620001	MATTE TIN / LEAD
754625001	MATTE TIN

CLARIFY PCB ZONES EC NO: UCP2013-5614 DRW:BBARKER 2013/07/05 CHKD:DMORGAN 2013/07/08 APPR:SMILLER 2013/07/31	QUALITY SYMBOLS 	GENERAL TOLERANCES (UNLESS SPECIFIED)		DIMENSION STYLE MM ONLY		SCALE 3:1	DESIGN UNITS METRIC	THIRD ANGLE PROJECTION																		
		<table border="1"> <thead> <tr> <th></th> <th>mm</th> <th>INCH</th> </tr> </thead> <tbody> <tr> <td>4 PLACES</td> <td>± ---</td> <td>± ---</td> </tr> <tr> <td>3 PLACES</td> <td>± ---</td> <td>± ---</td> </tr> <tr> <td>2 PLACES</td> <td>± 0.13</td> <td>± ---</td> </tr> <tr> <td>1 PLACE</td> <td>± 0.25</td> <td>± ---</td> </tr> <tr> <td>0 PLACE</td> <td>±</td> <td>±</td> </tr> </tbody> </table>		mm	INCH	4 PLACES	± ---	± ---	3 PLACES	± ---	± ---	2 PLACES	± 0.13	± ---	1 PLACE	± 0.25	± ---	0 PLACE	±	±	DRAWN BY BBARKER	DATE 2013/07/05	TITLE STACKED SFP 2X1 MEDIUM HEIGHT ASS'Y, PRESS-FIT TAIL WITHOUT LIGHT PIPES			
		mm	INCH																							
	4 PLACES	± ---	± ---																							
3 PLACES	± ---	± ---																								
2 PLACES	± 0.13	± ---																								
1 PLACE	± 0.25	± ---																								
0 PLACE	±	±																								
		CHECKED BY 	DATE 																							
		APPROVED BY 	DATE 	MATERIAL NO. SEE TABLE		DOCUMENT NO. SD-75462-100	SHEET NO. 1 OF 4																			
		DRAFT WHERE APPLICABLE MUST REMAIN WITHIN DIMENSIONS		THIS DRAWING CONTAINS INFORMATION THAT IS PROPRIETARY TO MOLEX INCORPORATED AND SHOULD NOT BE USED WITHOUT WRITTEN PERMISSION																						

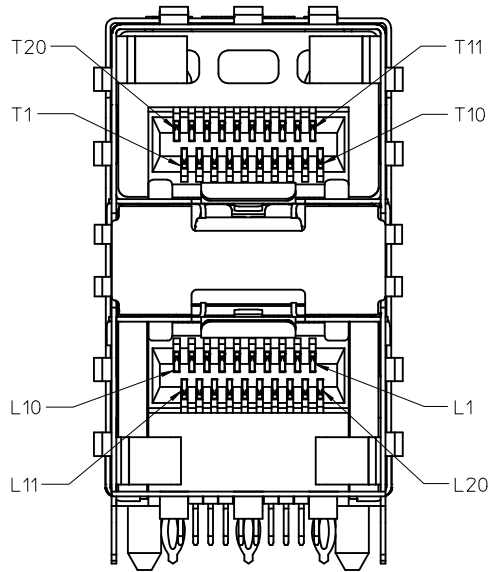
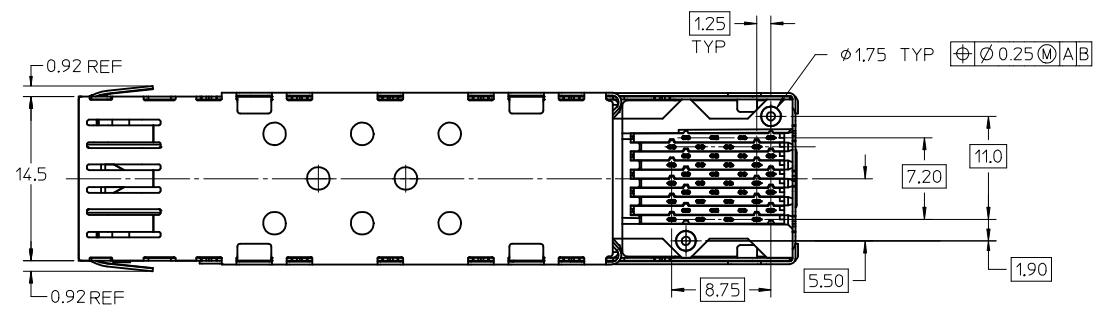

SCALE 5:1
CIRCUIT NUMBERING

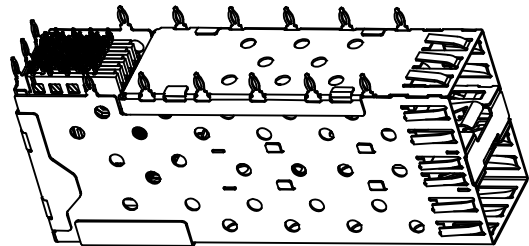

SEE SHEET 1 EC NO: UCP2013-5614 2013/07/05 IDRW:BBARKER 2013/07/08 CHKD:JMORGAN 2013/07/31 APPR:SMILLER	QUALITY SYMBOLS ▽=0 ▽=0 ▽=0	GENERAL TOLERANCES (UNLESS SPECIFIED)		DIMENSION STYLE MM ONLY	SCALE 3:1	DESIGN UNITS METRIC	THIRD ANGLE PROJECTION
		4 PLACES ± --- ± --- 3 PLACES ± --- ± --- 2 PLACES ± 0.13 ± --- 1 PLACE ± 0.25 ± --- 0 PLACE ± ±	mm INCH	DRAWN BY BBARKER	DATE 2013/07/05	TITLE STACKED SFP 2X1 MEDIUM HEIGHT ASS'Y, PRESS-FIT TAIL WITHOUT LIGHT PIPES	
		ANGULAR ± 5 °	DRAFT WHERE APPLICABLE MUST REMAIN WITHIN DIMENSIONS	CHECKED BY DATE	APPROVED BY DATE	DOCUMENT NO. SD-75462-100	
	MATERIAL NO. SEE TBL, SHT 1	SIZE C	THIS DRAWING CONTAINS INFORMATION THAT IS PROPRIETARY TO MOLEX INCORPORATED AND SHOULD NOT BE USED WITHOUT WRITTEN PERMISSION		SHEET NO. 2 OF 4		

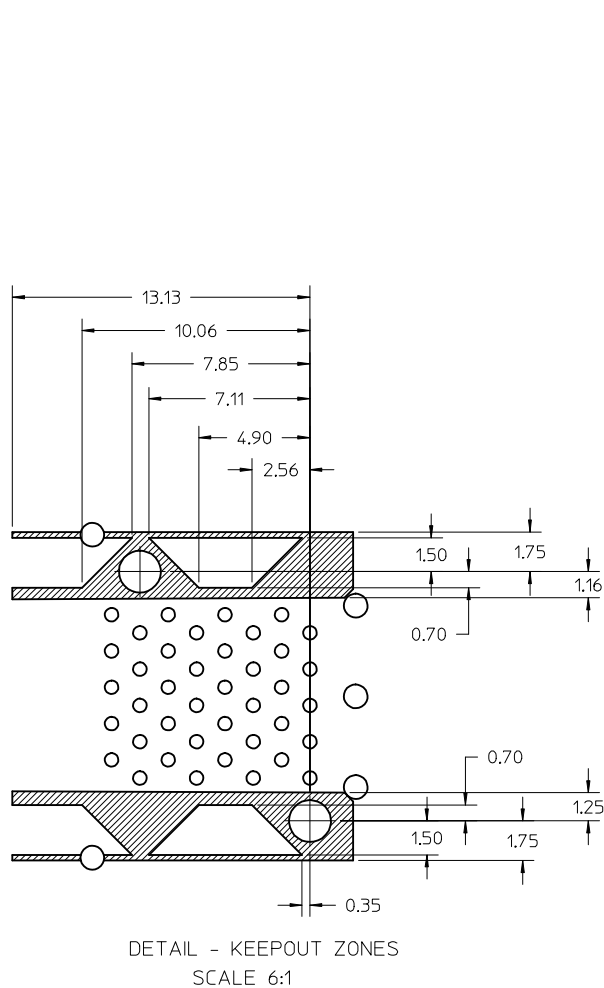

DETAIL - KEEPOUT ZONES
SCALE 6:1

THE HATCHED AREA IN THIS VIEW INDICATES ZONES THAT ARE OCCUPIED BY THE PLASTIC HOUSING THAT SEATS AGAINST THE PCB AND BY THE VERTICAL METAL CAGE WALL THAT STOPS JUST SHORT OF THE PCB

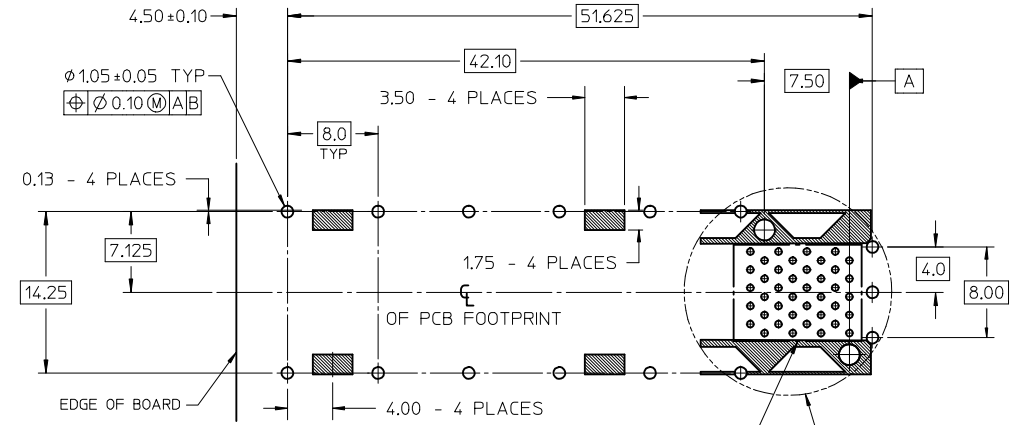

RECOMMENDED PCB LAYOUT - COMPONENT SIDE
RECOMMENDED PCB THICKNESS: 2.36 MM (.093 INCH)
(MINIMUM PCB THICKNESS: 1.57)
THE ENTIRE AREA OF THE CONNECTOR FOOTPRINT TO BE CONSIDERED THE KEEP OUT AREA FOR COMPONENTS
THIS AREA IS INDICATED BY THE DASHED LINE

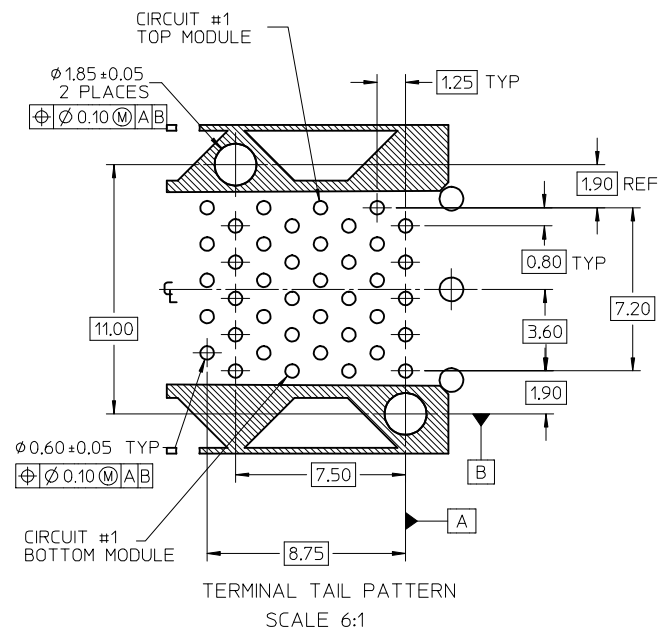

TERMINAL TAIL PATTERN
SCALE 6:1

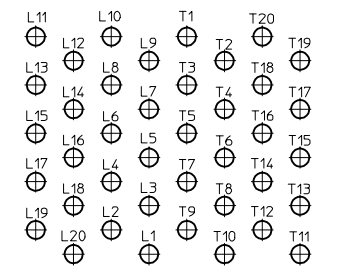

CIRCUIT NUMBERING
COMPONENT SIDE OF BOARD
SCALE 8:1

SEE SHEET 1 EC NO: UCP2013-5614 DRWN:BBARKER 2013/07/05 CHKD:DMORGAN 2013/07/08 APPR:SMILLER 2013/07/31	QUALITY SYMBOLS ▽=0 ▽=0 ▽=0	GENERAL TOLERANCES (UNLESS SPECIFIED)		DIMENSION STYLE MM ONLY	SCALE 3:1	DESIGN UNITS METRIC	THIRD ANGLE PROJECTION		
		4 PLACES ± --- ± --- 3 PLACES ± --- ± --- 2 PLACES ± 0.13 ± --- 1 PLACE ± 0.25 ± --- 0 PLACE ± ±	mm INCH ± --- ± --- ± --- ± --- ± 0.25 ± --- ± ±	DRAWN BY BBARKER	DATE 2013/07/05	TITLE STACKED SFP 2X1 MEDIUM HEIGHT ASS'Y, PRESS-FIT TAIL WITHOUT LIGHT PIPES	molex		
		ANGULAR ± 5 °		CHECKED BY DATE	APPROVED BY DATE	MATERIAL NO. SEE TBL, SHT 1	DOCUMENT NO. SD-75462-100	SHEET NO. 3 OF 4	
		DRAFT WHERE APPLICABLE MUST REMAIN WITHIN DIMENSIONS		THIS DRAWING CONTAINS INFORMATION THAT IS PROPRIETARY TO MOLEX INCORPORATED AND SHOULD NOT BE USED WITHOUT WRITTEN PERMISSION					

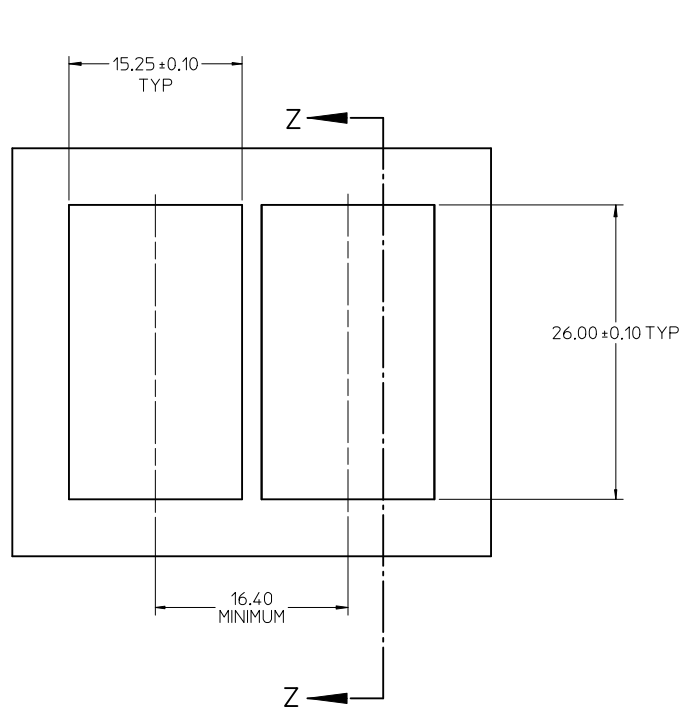

BEZEL CUT-OUT CENTER SPACING DETAIL
BEZEL THICKNESS 0.8 - 2.6

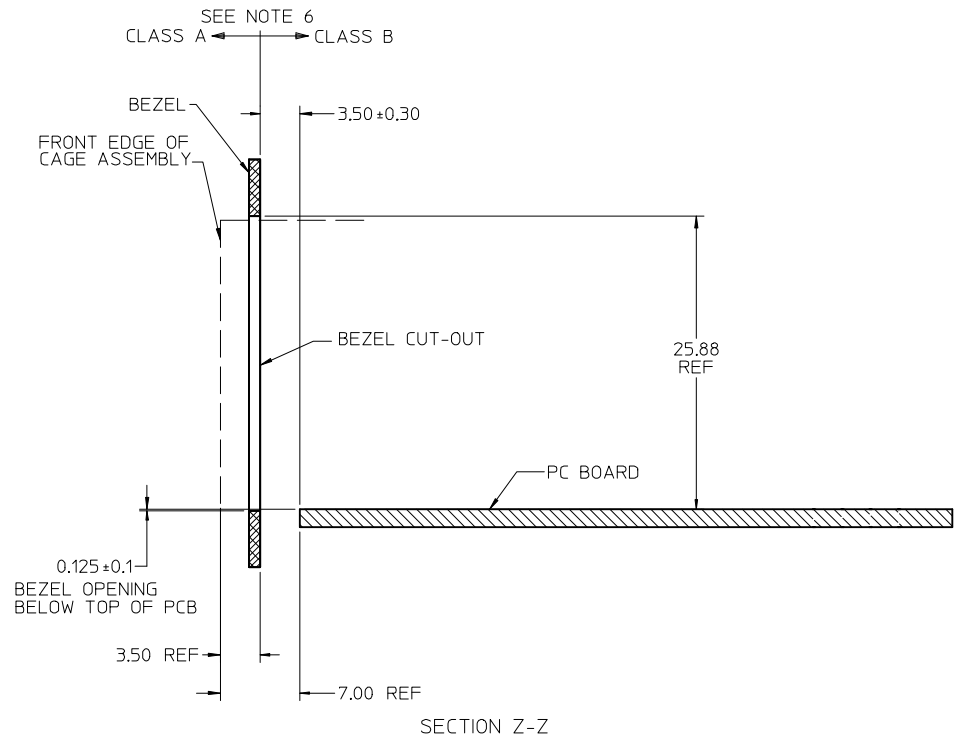

SECTION Z-Z

SEE SHEET 1 EC NO: UCP2013-5614 DRWN:BBARKER 2013/07/05 CHKD:MORGAN 2013/07/08 APPR:SMILLER 2013/07/31	QUALITY SYMBOLS = 0 = 0 = 0	GENERAL TOLERANCES (UNLESS SPECIFIED) <table border="1"> <thead> <tr> <th></th> <th>mm</th> <th>INCH</th> </tr> </thead> <tbody> <tr> <td>4 PLACES</td> <td>± ---</td> <td>± ---</td> </tr> <tr> <td>3 PLACES</td> <td>± ---</td> <td>± ---</td> </tr> <tr> <td>2 PLACES</td> <td>± 0.13</td> <td>± ---</td> </tr> <tr> <td>1 PLACE</td> <td>± 0.25</td> <td>± ---</td> </tr> <tr> <td>0 PLACE</td> <td>±</td> <td>±</td> </tr> </tbody> </table>		mm	INCH	4 PLACES	± ---	± ---	3 PLACES	± ---	± ---	2 PLACES	± 0.13	± ---	1 PLACE	± 0.25	± ---	0 PLACE	±	±	DIMENSION STYLE MM ONLY DRAWN BY: BBARKER DATE: 2013/07/05 CHECKED BY: _____ DATE: _____ APPROVED BY: _____ DATE: _____	SCALE: 3:1 DESIGN UNITS: METRIC THIRD ANGLE PROJECTION	TITLE: STACKED SFP 2X1 MEDIUM HEIGHT ASS'Y, PRESS-FIT TAIL WITHOUT LIGHT PIPES molex
		mm	INCH																				
	4 PLACES	± ---	± ---																				
	3 PLACES	± ---	± ---																				
2 PLACES	± 0.13	± ---																					
1 PLACE	± 0.25	± ---																					
0 PLACE	±	±																					
MATERIAL NO.: SEE TBL, SHT 1	DOCUMENT NO.: SD-75462-100	SHEET NO.: 4 OF 4	DRAFT WHERE APPLICABLE MUST REMAIN WITHIN DIMENSIONS																				
THIS DRAWING CONTAINS INFORMATION THAT IS PROPRIETARY TO MOLEX INCORPORATED AND SHOULD NOT BE USED WITHOUT WRITTEN PERMISSION																							