

PART NAME: KNOB

SCALE: 1:1

DATE: 6/16/88

DR. BY HD



DESIGNERS & MANUFACTURERS
OF KNOBS, HANDLES, CASES &
CUSTOM PLASTIC COMPONENTS

P/N 2830AJ

THIS DRAWING IS THE PROPERTY OF DAVIES MOLDING COMPANY, IS SUBMITTED SOLELY AS A DESIGN OR ENGINEERING PROJECT.
WE ACCEPT NO RESPONSIBILITY WHATSOEVER FOR THE PRACTICAL APPLICATION OF THE PIECES MADE TO THIS DESIGN.

M^{NO.} 2890-2830

CAD/REDRAWN : 4/13/93 ; HD

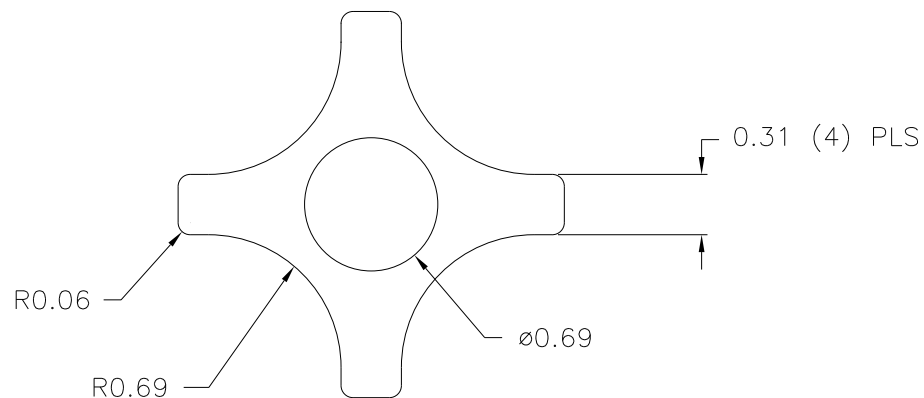

(A)

| | |
|----------------|--------|
| CAVITY | 2830 |
| PLUNGER | 2830 |
| PLUNGER PIN | 2830 |
| PINS | 3000-E |
| LANDING BAR | .472 |
| PIN PLATE SHIM | .498 |
| SHIM | .018 |
| INSERT | I1528 |

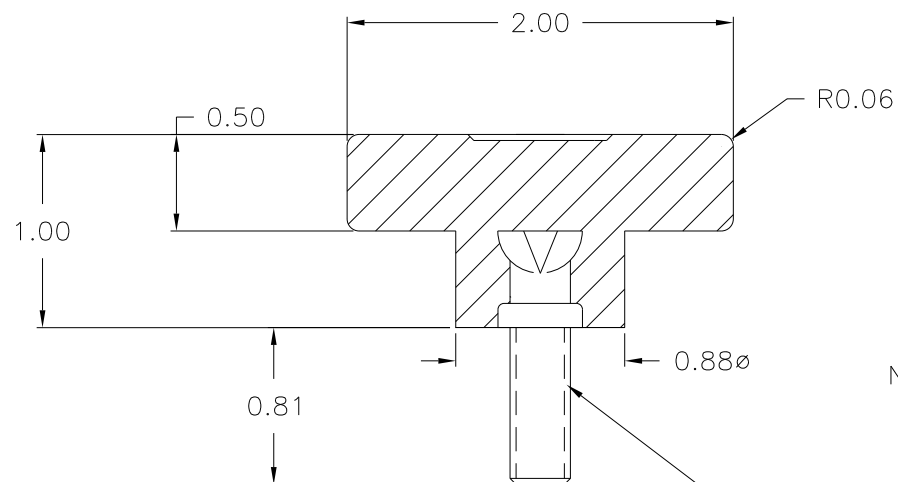

NOTE : TUBE (T0135) MUST BE INSTALLED
ABOVE ALL MOLDED PARTS

5/16-18 UNC-2 THREAD
I1528, STAINLESS STEEL

MATERIAL: #4311 PLENCO PHENOLIC (B41)
COLOR: BLACK

| | | | | | |
|---|----------------------------------|---------|---------------|----|---------|
| TOLERANCES: UNLESS OTHERWISE SPECIFIED | DO NOT SCALE DRAWING | A | SHIM WAS .078 | ST | 5/11/01 |
| | | - | UPDATED DWG | HD | 4/28/97 |
| DECIMALS: X.XXX ± .005 X.XX ± .015 | MM: X.XX ± 0.15MM X.X ± 0.4MM | - | CAD/REDRAWN | HD | 4/13/93 |
| FRACTIONS ± 1/64 | ANG. ± 1° | CHANGES | | | |