

DRV8860 Customer Evaluation Module

This user guide for the DRV8860 customer evaluation module (EVM) supplements the DRV8860 device. It details the hardware and GUI implementation of the EVM. DRV8860 EVM is a complete solution for evaluating the DRV8860 8-channel serial-interface low-side driver.

Contents

1	Introduction	1
2	EVM Hardware	2
	2.1 PCB Overview	2
	2.2 EVM Connections	3
	2.3 Jumper	6
	2.4 Test Points	6
	2.5 Schematic	7
	2.6 Bill of Materials	9
3	GUI Installation and Operation	10
	3.1 Install the GUI Software	10
	3.2 Install the USB Driver	10
	3.3 GUI Overview	10
	3.4 Start-Up Operation	13
	3.5 KEY and Indicator Function of the EVM	13

List of Tables

1	Full-Step Sequence	12
2	Half-Step Sequence	12
3	Key and Indicator Function	13

1 Introduction

The evaluation module includes two DRV8860 devices in a daisy-chain connection and an on-board MSP430F2350 microcontroller (MCU). A USB-to-UART interface on the board allows communication between the PC and the EVM. To setup the evaluation functions, connect the device with a USB wire to a computer USB port, apply 8-V to 38-V VM power to EVM, and install and launch the GUI software. The following functions are available through the DRV8860 device evaluation:

- Send specific output data from GUI to DRV8860.
- Read back the output states of DRV8860 and display on GUI.
- Read back the fault register of DRV8860 and display on GUI.
- Enable or disable the output of DRV8860 via GUI.
- Send control register including the energizing time and PWM duty to DRV8860.
- Provide an optional VM switch and can be controlled via GUI.
- Run four unipolar stepper motors with direction and micro-stepping (full or half) control.
- Send the same output pattern to up to 255 DRV8860 devices in daisy-chain connection.

After the functions are evaluated on this EVM, the board can separate the two DRV8860 circuits from the main board. This separation allows customers to apply their own systems for quick prototype verification. The board has spare connector pins, GPIOs, switches, and LEDs for customized tests or re-development.

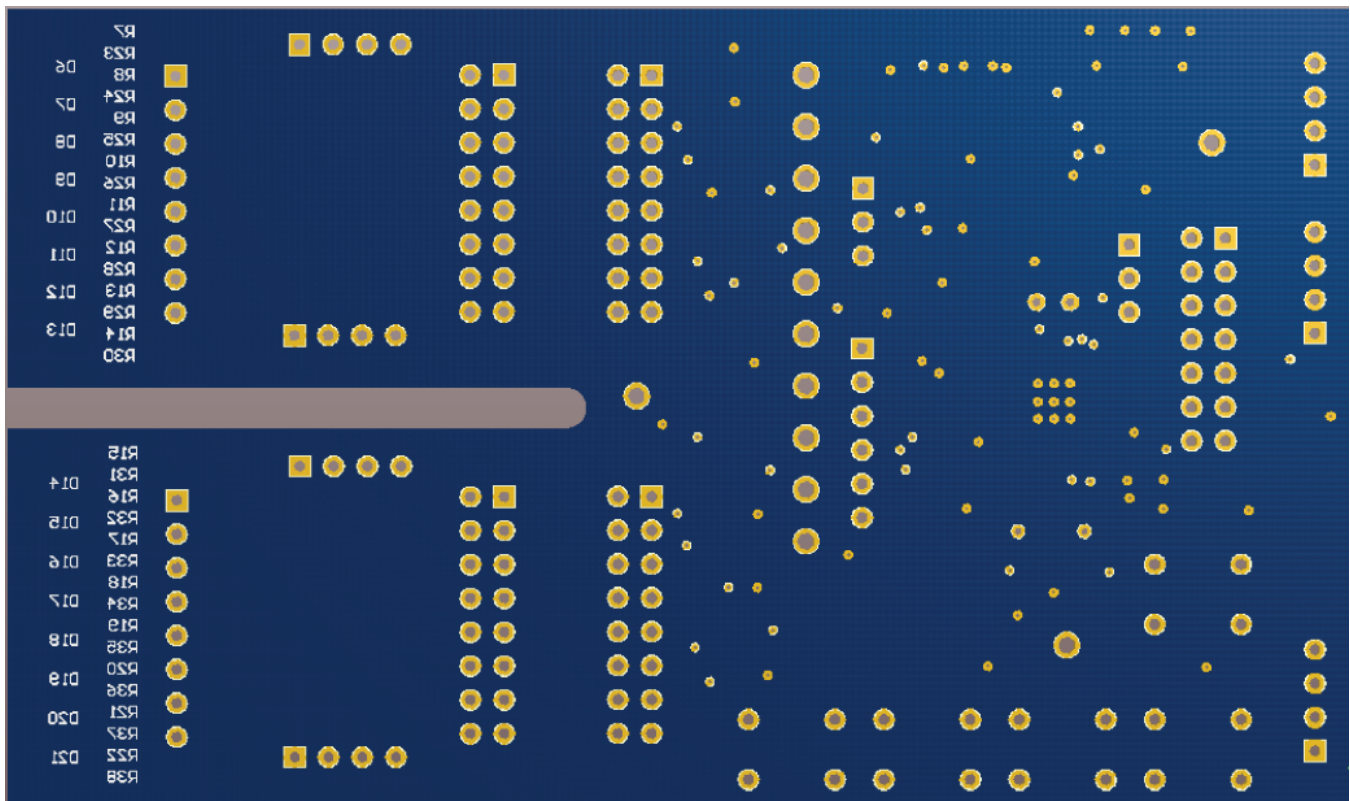

Figure 3. Bottom View (Includes Overlay of Output LEDs and Resistors)

2.2 EVM Connections

The evaluation module includes six connections.

- Power connection
- Optional VM switch connection
- Computer USB connection
- Normal-load connection
- LED-load connection
- Motor-load connection

2.2.1 Power Connection

TI recommends a lab power supply within the 8-V to 38-V range and a 2-A current limit function for the evaluation process.

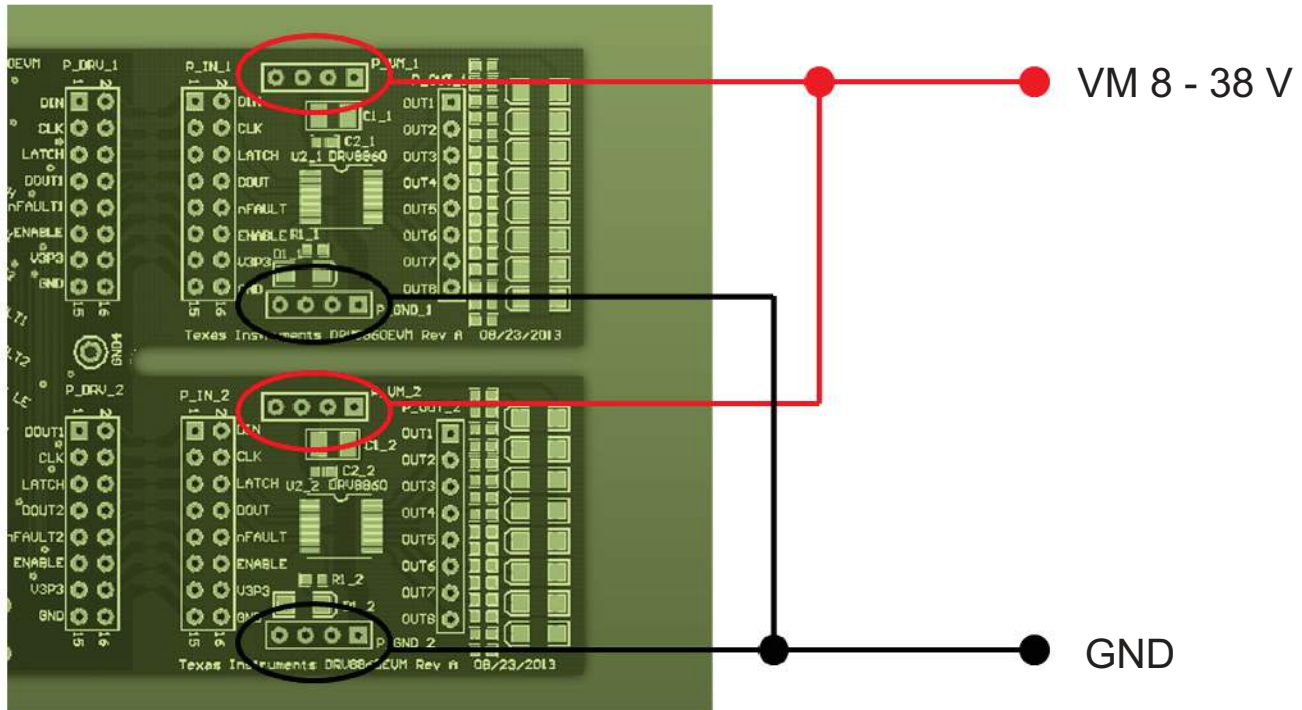

Figure 4. VM Power Connection for DRV8860

2.2.2 Optional VM Switch Connection

DRV8860 has an on-chip open-load detect function. This function causes an additional 30- μ A current consumption by each channel. An optional VM switch on the board shuts down the DRV8860 circuit from the power supply.

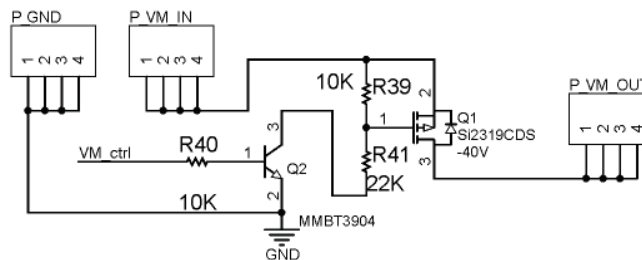

Figure 5. Optional VM Power Switch Circuit

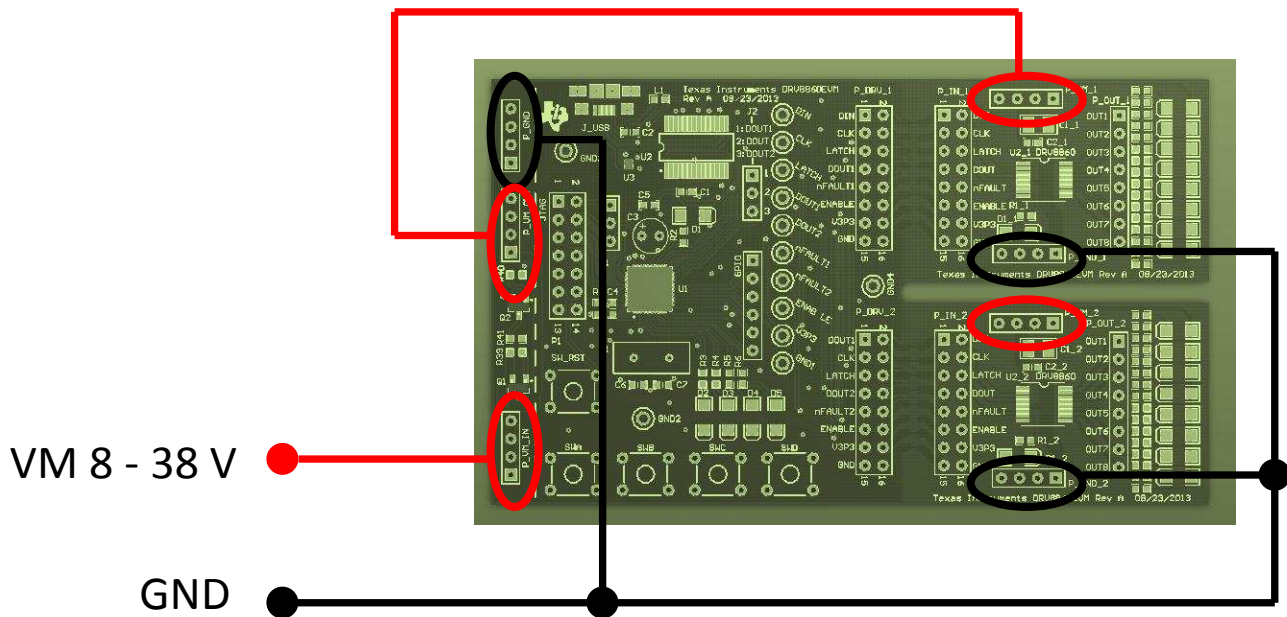

Figure 6. Connected Power Supply With the VM Switch

2.2.3 Computer USB Connection

Use the micro-USB wire along with the EVM kit to connect to any computer with the USB-to-UART interface driver already installed. (Refer to [Section 3.2](#) to learn how to install the driver.) This USB connection serves as the data transfer as well as the 5-V power supply for the on-board FT232 part and the 3.3-V out of the FT232 to the MSP430 MCU.

After the USB wire connects, LED D1 starts flashing.

2.2.4 Load Connection

Eight LEDs serve as virtual load indicators on the board. Other loads such as relays, solenoids, heaters, bulbs, and motors can connect between each of the outputs to VM in a single connection or parallel. Refer to the DRV8860 device specifications for more information on current capability and power consumption.

2.2.5 LED Load Connection

If the LED is driven (similar to the EVM) beside the current-limit resistor, TI recommends connecting an additional resistor of 27 k Ω from the output to the VM. During the output off state, the open-load detection circuit inside DRV8860 sinks 30 μ A from the load path. Although the 30- μ A current is low, it causes the LED to emit a dim light during the off state. A 27 k Ω bypass resistor clamps the voltage drop to < 1 V in 30- μ A condition, so that the LED can be totally shut off because 1 V does not suffice to reach the light threshold for most types of LED.

2.2.6 Motor Connection

For the unipolar motor connection, connect the motor wires to the driver (see [Figure 7](#)) to get the motor driven properly with the sequence built in the firmware of the MCU on board. (The unipolar motor is not included in the EVM kit. The current of the motor should be within the OCP 500-mA range. For example, if VM is 12 V, the DC resistance of the motor phase-to-CT should > 24 Ω).

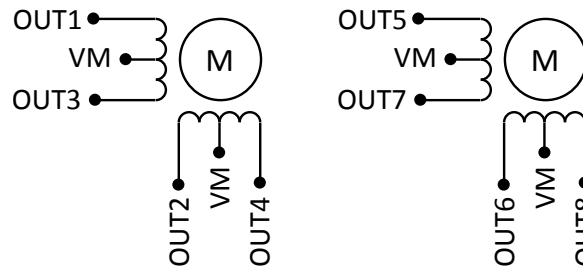

Figure 7. Unipolar Motor Connection (Identical for 1 and 2)

2.3 Jumper

The only jumper in the EVM is J2. See Figure 8 for jumper settings.

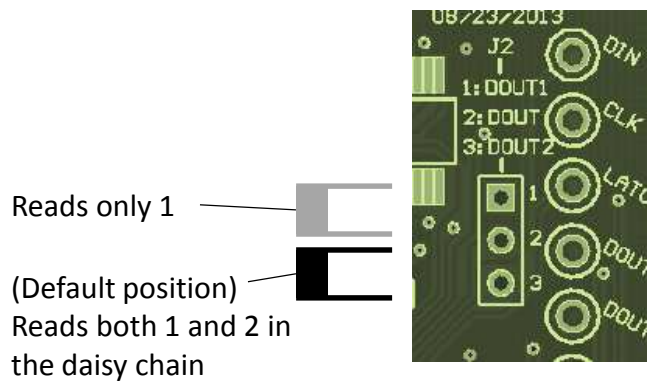

Figure 8. Jumper Settings

2.4 Test Points

All the test points on EVM have clear labels beside them. The dual header can be both a connection and test point. All test points (or pins) with the same label are physically connected and have the same net. GND, GND1, GND2, GND3, and GND4 have the same net GND.

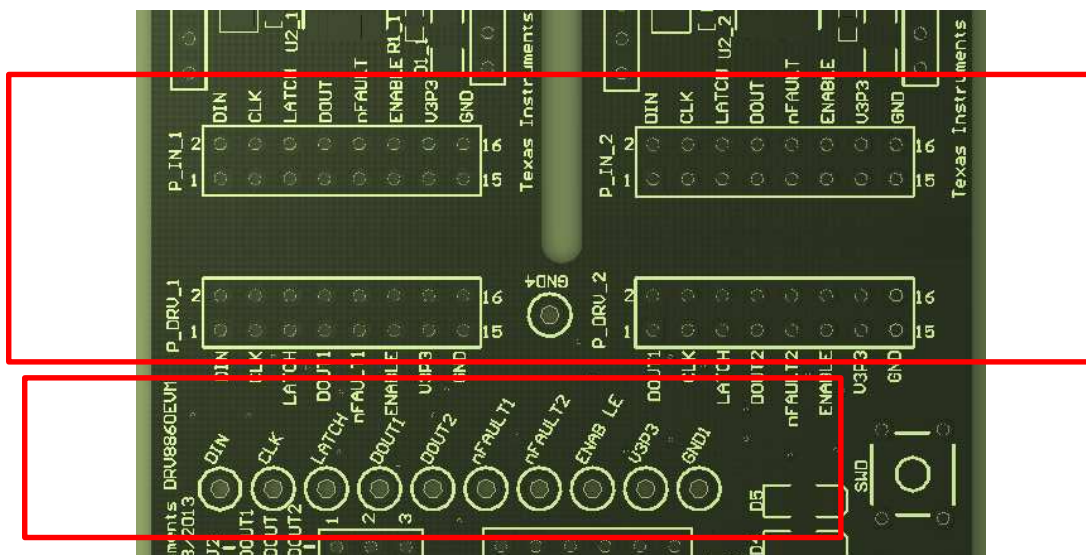

Figure 9. Test Points in the EVM

2.5 Schematic

For a more detailed schematic, refer to the schematic file in the EVM reference package.

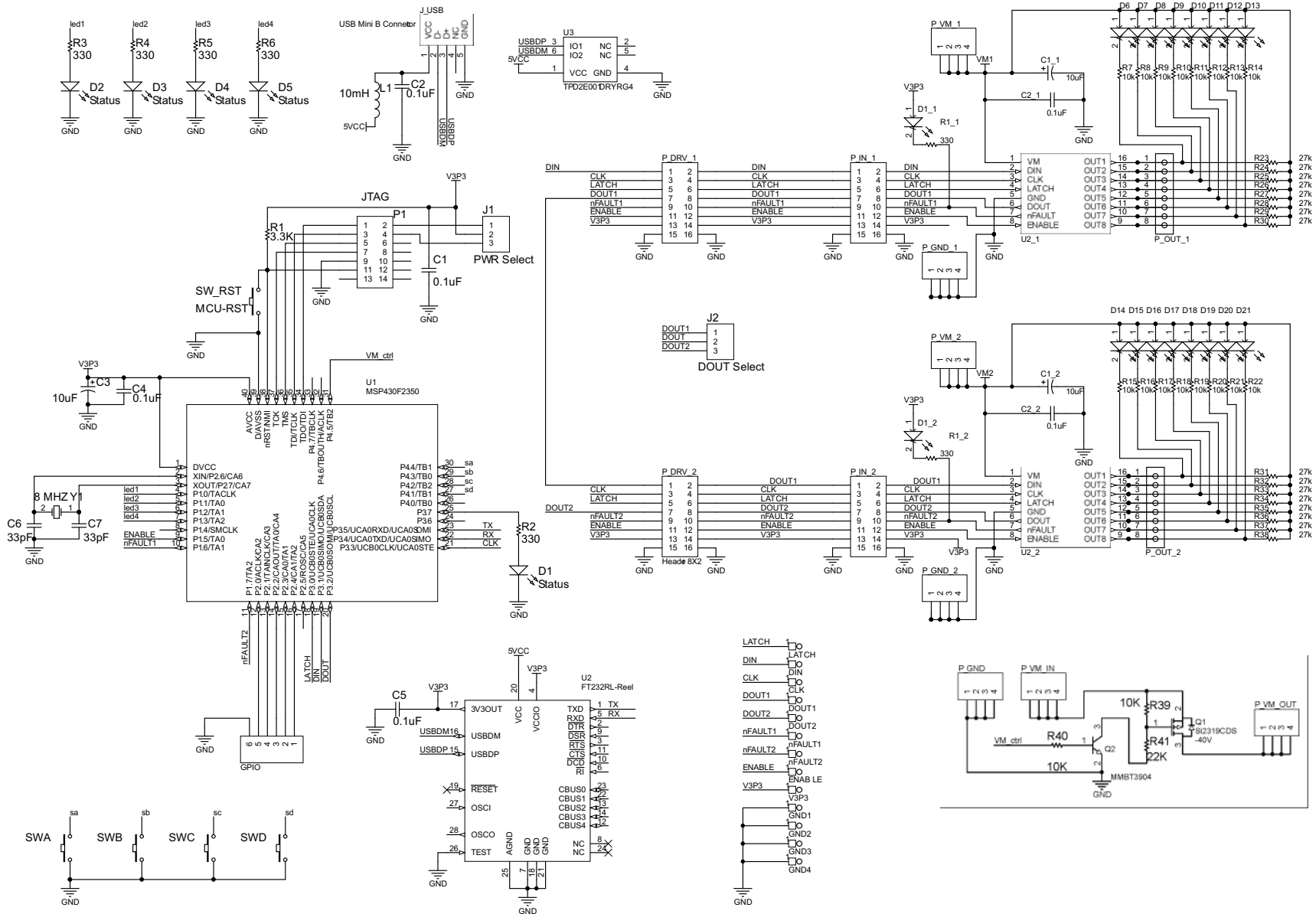

Figure 10. Schematic

2.6 Bill of Materials

Items	Designator	Vendor	Vendor Part #	Quantity	Description
1	C1, C2, C4, C5	Digi-Key	311-1341-1-ND	4	CAP CER 0.1UF 25V 10% X7R 0603
2	C1_1, C1_2	Digi-Key	587-3248-1-ND	2	CAP CER 10UF 50V 20% X5R 1206
3	C2_1, C2_2	Digi-Key	311-1343-1-ND	2	CAP CER 0.1UF 50V Y5V 0603
4	C3	Digi-Key	493-1057-ND	1	CAP ALUM 10UF 25V 20% RADIAL
5	C6, C7	Digi-Key	478-6211-1-ND	2	CAP CER 33PF 16V 5% X7R 0603
6	CLK, DIN, DOUT1, DOUT2, ENAB LE, LATCH, nFAULT1, nFAULT2, V3P3	Digi-Key	5007K-ND	9	TEST POINT PC COMPACT .063"D WHT
7	GND1, GND2, GND3, GND4	Digi-Key	5006K-ND	4	TEST POINT PC COMPACT .063"D BLK
8	D1, D2, D3, D4, D5	Digi-Key	P11532CT-ND	5	LED RED FACE UP 1206
9	D1_1	Digi-Key	P11532CT-ND	1	LED RED FACE UP 1206
10	D1_2	Digi-Key	P11532CT-ND	1	LED RED FACE UP 1206
11	D6, D7, D8, D9, D10, D11, D12, D13, D14, D15, D16, D17, D18, D19, D20, D21	Digi-Key	P11532CT-ND	16	LED RED FACE UP 1206
12	GPIO	Digi-Key	929647-09-05-ND	1	CONN HEADER .100 SNGL STR 5POS
13	J1	Digi-Key	929647-09-03-ND	1	CONN HEADER .100 SNGL STR 3POS
14	J2	Digi-Key	929647-09-03-ND	1	CONN HEADER .100 SNGL STR 3POS
15	J_USB	Digi-Key	A97799CT-ND	1	CONN RCPT MICRO USB TYPE AB
16	L1	Digi-Key	445-2988-1-ND	1	FERRITE CHIP 100 OHM 1A 0603
17	P1	Digi-Key	929665-09-07-ND	1	CONN HEADER .100 DUAL STR 14POS
18	P_DRV_1, P_DRV_2, P_IN_1, P_IN_2	Digi-Key	929665-09-08-ND	4	CONN HEADER .100 DUAL STR 16POS
19	P_GND, P_GND_1, P_GND_2, P_VM_1, P_VM_2, P_VM_IN, P_VM_OUT	Digi-Key	929647-09-04-ND	7	CONN HEADER .100 SNGL STR 4POS
20	P_OUT_1, P_OUT_2	Digi-Key	929647-09-08-ND	2	CONN HEADER .100 SNGL STR 8POS
21	Q1	Digi-Key	SI2319CDS-T1-GE3CT-ND	1	MOSFET P-CH 40V SOT-23
22	Q2	Digi-Key	MMBT3904-FDICT-ND	1	TRANS NPN 40V 350MW SMD SOT23-3
23	R1	Digi-Key	P3.3KGCT-ND	1	RES 3.3K OHM 1/10W 5% 0603 SMD
24	R1_1, R1_2	Digi-Key	P330GCT-ND	2	RES 330 OHM 1/10W 5% 0603 SMD
25	R2, R3, R4, R5, R6	Digi-Key	P330GCT-ND	5	RES 330 OHM 1/10W 5% 0603 SMD
26	R7, R8, R9, R10, R11, R12, R13, R14, R15, R16, R17, R18, R19, R20, R21, R22	Digi-Key	P10KGCT-ND	16	RES 10K OHM 1/10W 5% 0603 SMD
27	R23, R24, R25, R26, R27, R28, R29, R30, R31, R32, R33, R34, R35, R36, R37, R38	Digi-Key	P27KGCT-ND	16	RES 27K OHM 1/10W 5% 0603 SMD
28	R39, R40	Digi-Key	P10KGCT-ND	2	RES 10K OHM 1/10W 5% 0603 SMD
29	R41	Digi-Key	P22KGCT-ND	1	RES 22K OHM 1/10W 5% 0603 SMD
30	SW_RST, SWA, SWB, SWC, SWD	Digi-Key	SW400-ND	5	SWITCH TACTILE SPST-NO 0.05A 24V
31	U1	Digi-Key	296-21749-2-ND	1	IC MCU 16BIT 16KB FLASH 40VQFN
32	U2	Digi-Key	768-1007-1-ND	1	IC USB FS SERIAL UART 28-SSOP
33	U2_1, U2_2	N/A	N/A	2	(Supplied) 8 Channel Serial Interface Low-Side Driver
34	U3	Digi-Key	296-21884-1-ND	1	IC ESD-PROT ARRAY 2CH 6-SON
35	Y1	Digi-Key	X1094-ND	1	CRYSTAL 8.00 MHZ 20PF 49US

3 GUI Installation and Operation

Before running the GUI and commands, be familiar with the EVM hardware and the DRV8860 device specifications and functions. The following steps explain the GUI installation and operation.

3.1 Install the GUI Software

To install the GUI software, double click setup.exe in the install package folder. Follow the prompts until the installation is complete. A system restart may be necessary to properly launch the software after installation.

3.2 Install the USB Driver

The USB driver is for the FT232RL device. Windows 7 or 8 systems can experience issues installing the driver. One method to install the driver on a Windows 7 or 8 system is to change the properties of the driver (see [Figure 11](#)).

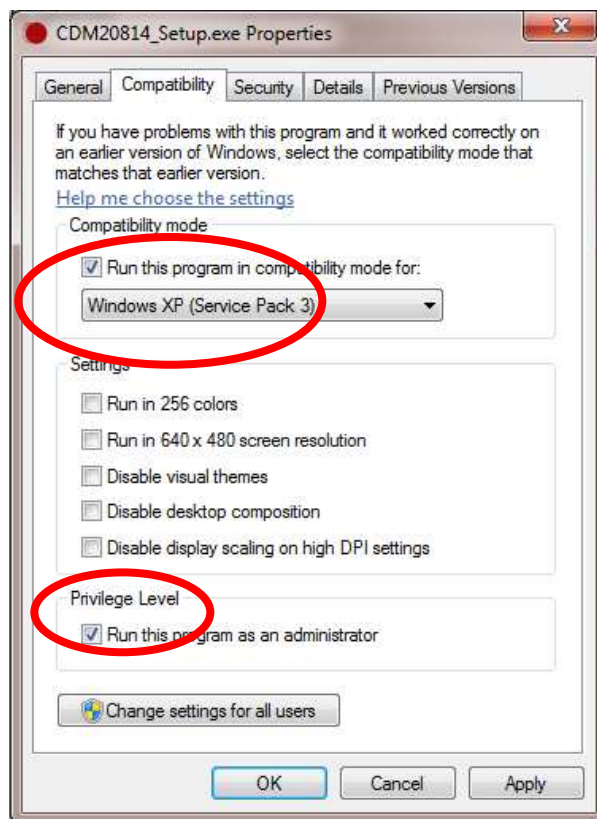

Figure 11. USB Driver Installation for Windows 7 and 8

3.3 GUI Overview

There are six main areas in the GUI. Refer to the following sections for more information and operating procedures.

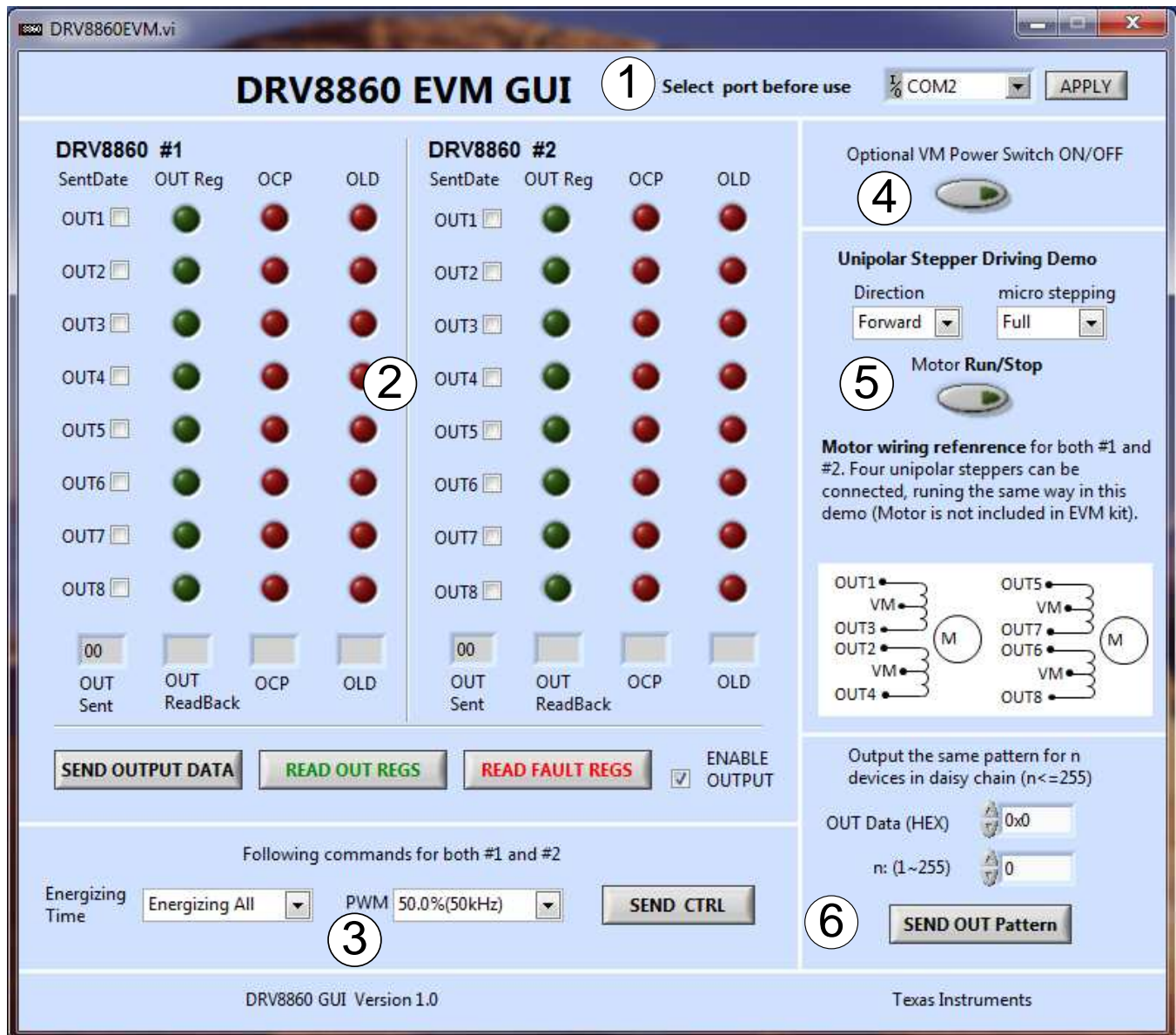

Figure 12. GUI Interface

3.3.1 COM Port Selection

After launching the GUI, the first step is to select the proper COM port. Although this port value is designed so it can be changed after other operations, TI recommends setting it correctly in the beginning. Check the COM port information in the my computer properties in your system to be sure of the COM port value for the EVM kit. COM2 is commonly assigned to the port.

Note: if the COM number is set incorrectly, no prompts or errors appear, nor a response from the EVM.

3.3.2 Send Output Data, Read Back Output Register States, and Read Back Fault Register and Enable.

Operation flow: Select the check box SEND OUTPUT DATA, READ OUT REGS, then READ FAULT REGS.

1. Check the box of OUT1 to OUT8 as needed, then click SEND OUTPUT DATA. The output of DRV8860 changes the state accordingly. There is a HEX indicator below the check box that displays the output data in HEX format.

2. Click READ OUT REGS. The real output register value of the current state reads back to the MCU and sends back to GUI. The green bulbs light according to the states. If the command correctly sends to the MCU, the MCU gives SPI control to DRV8860, and after read-back, the green bulbs match the checked boxes.
3. Click the READ FAULT REGS button. The 16-bit fault register, including 8-bit OCP and 8-bit OLD information, read back to GUI. Note that real OCP occurs when the output bit is in the ON state. Real OLD information detects when the output bit is in the OFF state.
4. The ENABLE OUTPUT check box controls the ENABLE pin of the two DRV8860 devices. If it is checked off, the ENABLE pin drives low. All outputs shut off even if the output register is on.

3.3.3 Energizing Time and PWM Duty Selection

Select the energizing time and PWM duty cycle to control register value builds. After clicking SEND CTRL, the output states change immediately according to the control register value. To recover 100% duty operation, select Energizing All Time in the drop-down options of the energizing menu and click SEND CTRL.

3.3.4 Control the Optional VM Power Switch

Controls the optional VM power switch by selecting on or off.

3.3.5 Running Unipolar Stepper Motors.

The motor wire connections to the output pins are shown in the GUI. Refer to [Section 2](#) for more information.

The driving full-step and half-step sequences are shown in [Table 1](#) and [Table 2](#).

Table 1. Full-Step Sequence

Step Index	OUT1 (5)	OUT2 (6)	OUT3 (7)	OUT4 (8)
1	1	0	0	1
2	1	1	0	0
3	0	1	1	0
4	0	0	1	1

Table 2. Half-Step Sequence

Step Index	OUT1 (5)	OUT2 (6)	OUT3 (7)	OUT4 (8)
1	1	0	0	0
2	1	1	0	0
3	0	1	0	0
4	0	1	1	0
5	0	0	1	0
6	0	0	1	1
7	0	0	0	1
8	1	0	0	1

3.3.6 Output the Same Pattern to n Devices in Daisy Chain.

This function sends the same output pattern to as many as 255 devices in the daisy chain. If $n = 2$, the function is the same as the output data sent in block two. To function on more than two parts, the hardware daisy chain connection needs more than two devices ready.

3.4 Start-Up Operation

If VM power is applied first, then the USB wire is connected, the output LEDs start a self-checking process in two seconds. LEDs flash in a scrolling-line pattern, then as a pulsing on-and-off pattern.

This startup procedure serves as a self check on the outputs and SPI communication. In any operation state, press the SW_RST button to restart the MCU code and start-up the self-checking process again.

3.5 KEY and Indicator Function of the EVM

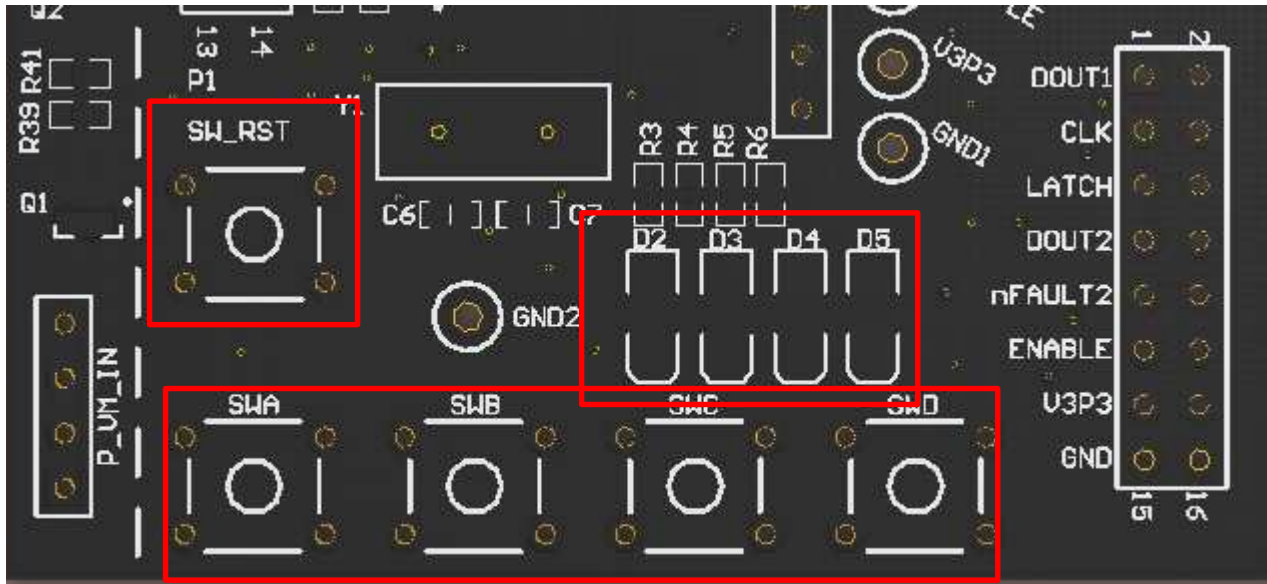

Figure 13. KEY and LED Indicators

SW_RST is the MCU reset key. SWA to SWD are designed as toggling switches for EN, LATCH, CLK, and DIN signals. D2 to D5 turn the light on or off according to the high or low state of these signals. Refer to Table 3 for more information.

Table 3. Key and Indicator Function

Key	Function	LED
SWA Pressed	Toggle EN: H	D2 : Light
	Toggle EN: L	D2 : Dark
SWB Pressed	Toggle LATCH: H	D3 : Light
	Toggle LATCH: L	D3 : Dark
SWC Pressed	Toggle CLK: H	D4 : Light
	Toggle CLK: L	D4 : Dark
SWD Pressed	Toggle DIN: H	D5 : Light
	Toggle DIN: L	D5 : Dark

EVALUATION BOARD/KIT/MODULE (EVM) ADDITIONAL TERMS

Texas Instruments (TI) provides the enclosed Evaluation Board/Kit/Module (EVM) under the following conditions:

The user assumes all responsibility and liability for proper and safe handling of the goods. Further, the user indemnifies TI from all claims arising from the handling or use of the goods.

Should this evaluation board/kit not meet the specifications indicated in the User's Guide, the board/kit may be returned within 30 days from the date of delivery for a full refund. THE FOREGOING LIMITED WARRANTY IS THE EXCLUSIVE WARRANTY MADE BY SELLER TO BUYER AND IS IN LIEU OF ALL OTHER WARRANTIES, EXPRESSED, IMPLIED, OR STATUTORY, INCLUDING ANY WARRANTY OF MERCHANTABILITY OR FITNESS FOR ANY PARTICULAR PURPOSE. EXCEPT TO THE EXTENT OF THE INDEMNITY SET FORTH ABOVE, NEITHER PARTY SHALL BE LIABLE TO THE OTHER FOR ANY INDIRECT, SPECIAL, INCIDENTAL, OR CONSEQUENTIAL DAMAGES.

Please read the User's Guide and, specifically, the Warnings and Restrictions notice in the User's Guide prior to handling the product. This notice contains important safety information about temperatures and voltages. For additional information on TI's environmental and/or safety programs, please visit www.ti.com/esh or contact TI.

No license is granted under any patent right or other intellectual property right of TI covering or relating to any machine, process, or combination in which such TI products or services might be or are used. TI currently deals with a variety of customers for products, and therefore our arrangement with the user is not exclusive. TI assumes no liability for applications assistance, customer product design, software performance, or infringement of patents or services described herein.

REGULATORY COMPLIANCE INFORMATION

As noted in the EVM User's Guide and/or EVM itself, this EVM and/or accompanying hardware may or may not be subject to the Federal Communications Commission (FCC) and Industry Canada (IC) rules.

For EVMs **not** subject to the above rules, this evaluation board/kit/module is intended for use for ENGINEERING DEVELOPMENT, DEMONSTRATION OR EVALUATION PURPOSES ONLY and is not considered by TI to be a finished end product fit for general consumer use. It generates, uses, and can radiate radio frequency energy and has not been tested for compliance with the limits of computing devices pursuant to part 15 of FCC or ICES-003 rules, which are designed to provide reasonable protection against radio frequency interference. Operation of the equipment may cause interference with radio communications, in which case the user at his own expense will be required to take whatever measures may be required to correct this interference.

General Statement for EVMs including a radio

User Power/Frequency Use Obligations: This radio is intended for development/professional use only in legally allocated frequency and power limits. Any use of radio frequencies and/or power availability of this EVM and its development application(s) must comply with local laws governing radio spectrum allocation and power limits for this evaluation module. It is the user's sole responsibility to only operate this radio in legally acceptable frequency space and within legally mandated power limitations. Any exceptions to this are strictly prohibited and unauthorized by Texas Instruments unless user has obtained appropriate experimental/development licenses from local regulatory authorities, which is responsibility of user including its acceptable authorization.

For EVMs annotated as FCC – FEDERAL COMMUNICATIONS COMMISSION Part 15 Compliant

Caution

This device complies with part 15 of the FCC Rules. Operation is subject to the following two conditions: (1) This device may not cause harmful interference, and (2) this device must accept any interference received, including interference that may cause undesired operation.

Changes or modifications not expressly approved by the party responsible for compliance could void the user's authority to operate the equipment.

FCC Interference Statement for Class A EVM devices

This equipment has been tested and found to comply with the limits for a Class A digital device, pursuant to part 15 of the FCC Rules. These limits are designed to provide reasonable protection against harmful interference when the equipment is operated in a commercial environment. This equipment generates, uses, and can radiate radio frequency energy and, if not installed and used in accordance with the instruction manual, may cause harmful interference to radio communications. Operation of this equipment in a residential area is likely to cause harmful interference in which case the user will be required to correct the interference at his own expense.

FCC Interference Statement for Class B EVM devices

This equipment has been tested and found to comply with the limits for a Class B digital device, pursuant to part 15 of the FCC Rules. These limits are designed to provide reasonable protection against harmful interference in a residential installation. This equipment generates, uses and can radiate radio frequency energy and, if not installed and used in accordance with the instructions, may cause harmful interference to radio communications. However, there is no guarantee that interference will not occur in a particular installation. If this equipment does cause harmful interference to radio or television reception, which can be determined by turning the equipment off and on, the user is encouraged to try to correct the interference by one or more of the following measures:

- Reorient or relocate the receiving antenna.
- Increase the separation between the equipment and receiver.
- Connect the equipment into an outlet on a circuit different from that to which the receiver is connected.
- Consult the dealer or an experienced radio/TV technician for help.

For EVMs annotated as IC – INDUSTRY CANADA Compliant

This Class A or B digital apparatus complies with Canadian ICES-003.

Changes or modifications not expressly approved by the party responsible for compliance could void the user's authority to operate the equipment.

Concerning EVMs including radio transmitters

This device complies with Industry Canada licence-exempt RSS standard(s). Operation is subject to the following two conditions: (1) this device may not cause interference, and (2) this device must accept any interference, including interference that may cause undesired operation of the device.

Concerning EVMs including detachable antennas

Under Industry Canada regulations, this radio transmitter may only operate using an antenna of a type and maximum (or lesser) gain approved for the transmitter by Industry Canada. To reduce potential radio interference to other users, the antenna type and its gain should be so chosen that the equivalent isotropically radiated power (e.i.r.p.) is not more than that necessary for successful communication.

This radio transmitter has been approved by Industry Canada to operate with the antenna types listed in the user guide with the maximum permissible gain and required antenna impedance for each antenna type indicated. Antenna types not included in this list, having a gain greater than the maximum gain indicated for that type, are strictly prohibited for use with this device.

Cet appareil numérique de la classe A ou B est conforme à la norme NMB-003 du Canada.

Les changements ou les modifications pas expressément approuvés par la partie responsable de la conformité ont pu vider l'autorité de l'utilisateur pour actionner l'équipement.

Concernant les EVMs avec appareils radio

Le présent appareil est conforme aux CNR d'Industrie Canada applicables aux appareils radio exempts de licence. L'exploitation est autorisée aux deux conditions suivantes : (1) l'appareil ne doit pas produire de brouillage, et (2) l'utilisateur de l'appareil doit accepter tout brouillage radioélectrique subi, même si le brouillage est susceptible d'en compromettre le fonctionnement.

Concernant les EVMs avec antennes détachables

Conformément à la réglementation d'Industrie Canada, le présent émetteur radio peut fonctionner avec une antenne d'un type et d'un gain maximal (ou inférieur) approuvé pour l'émetteur par Industrie Canada. Dans le but de réduire les risques de brouillage radioélectrique à l'intention des autres utilisateurs, il faut choisir le type d'antenne et son gain de sorte que la puissance isotrope rayonnée équivalente (p.i.r.e.) ne dépasse pas l'intensité nécessaire à l'établissement d'une communication satisfaisante.

Le présent émetteur radio a été approuvé par Industrie Canada pour fonctionner avec les types d'antenne énumérés dans le manuel d'usage et ayant un gain admissible maximal et l'impédance requise pour chaque type d'antenne. Les types d'antenne non inclus dans cette liste, ou dont le gain est supérieur au gain maximal indiqué, sont strictement interdits pour l'exploitation de l'émetteur.

【Important Notice for Users of EVMs for RF Products in Japan】

This development kit is NOT certified as Confirming to Technical Regulations of Radio Law of Japan

If you use this product in Japan, you are required by Radio Law of Japan to follow the instructions below with respect to this product:

1. Use this product in a shielded room or any other test facility as defined in the notification #173 issued by Ministry of Internal Affairs and Communications on March 28, 2006, based on Sub-section 1.1 of Article 6 of the Ministry's Rule for Enforcement of Radio Law of Japan,
2. Use this product only after you obtained the license of Test Radio Station as provided in Radio Law of Japan with respect to this product, or
3. Use of this product only after you obtained the Technical Regulations Conformity Certification as provided in Radio Law of Japan with respect to this product. Also, please do not transfer this product, unless you give the same notice above to the transferee. Please note that if you could not follow the instructions above, you will be subject to penalties of Radio Law of Japan.

Texas Instruments Japan Limited
(address) 24-1, Nishi-Shinjuku 6 chome, Shinjuku-ku, Tokyo, Japan

<http://www.tij.co.jp>

【無線電波を送信する製品の開発キットをお使いになる際の注意事項】

本開発キットは技術基準適合証明を受けておりません。

本製品のご使用に際しては、電波法遵守のため、以下のいずれかの措置を取っていただく必要がありますのでご注意ください。

1. 電波法施行規則第6条第1項第1号に基づく平成18年3月28日総務省告示第173号で定められた電波暗室等の試験設備でご使用いただく。
2. 実験局の免許を取得後ご使用いただく。
3. 技術基準適合証明を取得後ご使用いただく。

なお、本製品は、上記の「ご使用にあたっての注意」を譲渡先、移転先に通知しない限り、譲渡、移転できないものとします。

上記を遵守頂けない場合は、電波法の罰則が適用される可能性があることをご留意ください。

日本テキサス・インスツルメンツ株式会社
東京都新宿区西新宿6丁目24番1号
西新宿三井ビル

<http://www.tij.co.jp>

EVALUATION BOARD/KIT/MODULE (EVM) WARNINGS, RESTRICTIONS AND DISCLAIMERS

For Feasibility Evaluation Only, in Laboratory/Development Environments. Unless otherwise indicated, this EVM is not a finished electrical equipment and not intended for consumer use. It is intended solely for use for preliminary feasibility evaluation in laboratory/development environments by technically qualified electronics experts who are familiar with the dangers and application risks associated with handling electrical mechanical components, systems and subsystems. It should not be used as all or part of a finished end product.

Your Sole Responsibility and Risk. You acknowledge, represent and agree that:

1. You have unique knowledge concerning Federal, State and local regulatory requirements (including but not limited to Food and Drug Administration regulations, if applicable) which relate to your products and which relate to your use (and/or that of your employees, affiliates, contractors or designees) of the EVM for evaluation, testing and other purposes.
2. You have full and exclusive responsibility to assure the safety and compliance of your products with all such laws and other applicable regulatory requirements, and also to assure the safety of any activities to be conducted by you and/or your employees, affiliates, contractors or designees, using the EVM. Further, you are responsible to assure that any interfaces (electronic and/or mechanical) between the EVM and any human body are designed with suitable isolation and means to safely limit accessible leakage currents to minimize the risk of electrical shock hazard.
3. Since the EVM is not a completed product, it may not meet all applicable regulatory and safety compliance standards (such as UL, CSA, VDE, CE, RoHS and WEEE) which may normally be associated with similar items. You assume full responsibility to determine and/or assure compliance with any such standards and related certifications as may be applicable. You will employ reasonable safeguards to ensure that your use of the EVM will not result in any property damage, injury or death, even if the EVM should fail to perform as described or expected.
4. You will take care of proper disposal and recycling of the EVM's electronic components and packing materials.

Certain Instructions. It is important to operate this EVM within TI's recommended specifications and environmental considerations per the user guidelines. Exceeding the specified EVM ratings (including but not limited to input and output voltage, current, power, and environmental ranges) may cause property damage, personal injury or death. If there are questions concerning these ratings please contact a TI field representative prior to connecting interface electronics including input power and intended loads. Any loads applied outside of the specified output range may result in unintended and/or inaccurate operation and/or possible permanent damage to the EVM and/or interface electronics. Please consult the EVM User's Guide prior to connecting any load to the EVM output. If there is uncertainty as to the load specification, please contact a TI field representative. During normal operation, some circuit components may have case temperatures greater than 60°C as long as the input and output are maintained at a normal ambient operating temperature. These components include but are not limited to linear regulators, switching transistors, pass transistors, and current sense resistors which can be identified using the EVM schematic located in the EVM User's Guide. When placing measurement probes near these devices during normal operation, please be aware that these devices may be very warm to the touch. As with all electronic evaluation tools, only qualified personnel knowledgeable in electronic measurement and diagnostics normally found in development environments should use these EVMs.

Agreement to Defend, Indemnify and Hold Harmless. You agree to defend, indemnify and hold TI, its licensors and their representatives harmless from and against any and all claims, damages, losses, expenses, costs and liabilities (collectively, "Claims") arising out of or in connection with any use of the EVM that is not in accordance with the terms of the agreement. This obligation shall apply whether Claims arise under law of tort or contract or any other legal theory, and even if the EVM fails to perform as described or expected.

Safety-Critical or Life-Critical Applications. If you intend to evaluate the components for possible use in safety critical applications (such as life support) where a failure of the TI product would reasonably be expected to cause severe personal injury or death, such as devices which are classified as FDA Class III or similar classification, then you must specifically notify TI of such intent and enter into a separate Assurance and Indemnity Agreement.

Mailing Address: Texas Instruments, Post Office Box 655303, Dallas, Texas 75265
Copyright © 2013, Texas Instruments Incorporated

IMPORTANT NOTICE

Texas Instruments Incorporated and its subsidiaries (TI) reserve the right to make corrections, enhancements, improvements and other changes to its semiconductor products and services per JESD46, latest issue, and to discontinue any product or service per JESD48, latest issue. Buyers should obtain the latest relevant information before placing orders and should verify that such information is current and complete. All semiconductor products (also referred to herein as "components") are sold subject to TI's terms and conditions of sale supplied at the time of order acknowledgment.

TI warrants performance of its components to the specifications applicable at the time of sale, in accordance with the warranty in TI's terms and conditions of sale of semiconductor products. Testing and other quality control techniques are used to the extent TI deems necessary to support this warranty. Except where mandated by applicable law, testing of all parameters of each component is not necessarily performed.

TI assumes no liability for applications assistance or the design of Buyers' products. Buyers are responsible for their products and applications using TI components. To minimize the risks associated with Buyers' products and applications, Buyers should provide adequate design and operating safeguards.

TI does not warrant or represent that any license, either express or implied, is granted under any patent right, copyright, mask work right, or other intellectual property right relating to any combination, machine, or process in which TI components or services are used. Information published by TI regarding third-party products or services does not constitute a license to use such products or services or a warranty or endorsement thereof. Use of such information may require a license from a third party under the patents or other intellectual property of the third party, or a license from TI under the patents or other intellectual property of TI.

Reproduction of significant portions of TI information in TI data books or data sheets is permissible only if reproduction is without alteration and is accompanied by all associated warranties, conditions, limitations, and notices. TI is not responsible or liable for such altered documentation. Information of third parties may be subject to additional restrictions.

Resale of TI components or services with statements different from or beyond the parameters stated by TI for that component or service voids all express and any implied warranties for the associated TI component or service and is an unfair and deceptive business practice. TI is not responsible or liable for any such statements.

Buyer acknowledges and agrees that it is solely responsible for compliance with all legal, regulatory and safety-related requirements concerning its products, and any use of TI components in its applications, notwithstanding any applications-related information or support that may be provided by TI. Buyer represents and agrees that it has all the necessary expertise to create and implement safeguards which anticipate dangerous consequences of failures, monitor failures and their consequences, lessen the likelihood of failures that might cause harm and take appropriate remedial actions. Buyer will fully indemnify TI and its representatives against any damages arising out of the use of any TI components in safety-critical applications.

In some cases, TI components may be promoted specifically to facilitate safety-related applications. With such components, TI's goal is to help enable customers to design and create their own end-product solutions that meet applicable functional safety standards and requirements. Nonetheless, such components are subject to these terms.

No TI components are authorized for use in FDA Class III (or similar life-critical medical equipment) unless authorized officers of the parties have executed a special agreement specifically governing such use.

Only those TI components which TI has specifically designated as military grade or "enhanced plastic" are designed and intended for use in military/aerospace applications or environments. Buyer acknowledges and agrees that any military or aerospace use of TI components which have **not** been so designated is solely at the Buyer's risk, and that Buyer is solely responsible for compliance with all legal and regulatory requirements in connection with such use.

TI has specifically designated certain components as meeting ISO/TS16949 requirements, mainly for automotive use. In any case of use of non-designated products, TI will not be responsible for any failure to meet ISO/TS16949.

Products

Audio	www.ti.com/audio
Amplifiers	amplifier.ti.com
Data Converters	dataconverter.ti.com
DLP® Products	www.dlp.com
DSP	dsp.ti.com
Clocks and Timers	www.ti.com/clocks
Interface	interface.ti.com
Logic	logic.ti.com
Power Mgmt	power.ti.com
Microcontrollers	microcontroller.ti.com
RFID	www.ti-rfid.com
OMAP Applications Processors	www.ti.com/omap
Wireless Connectivity	www.ti.com/wirelessconnectivity

Applications

Automotive and Transportation	www.ti.com/automotive
Communications and Telecom	www.ti.com/communications
Computers and Peripherals	www.ti.com/computers
Consumer Electronics	www.ti.com/consumer-apps
Energy and Lighting	www.ti.com/energy
Industrial	www.ti.com/industrial
Medical	www.ti.com/medical
Security	www.ti.com/security
Space, Avionics and Defense	www.ti.com/space-avionics-defense
Video and Imaging	www.ti.com/video

TI E2E Community

e2e.ti.com