

LOC	DIST	REVISIONS				
P	LTR	DESCRIPTION	DATE	DWN	APVD	
GW	-	A	-	19APR2001	BL	KM

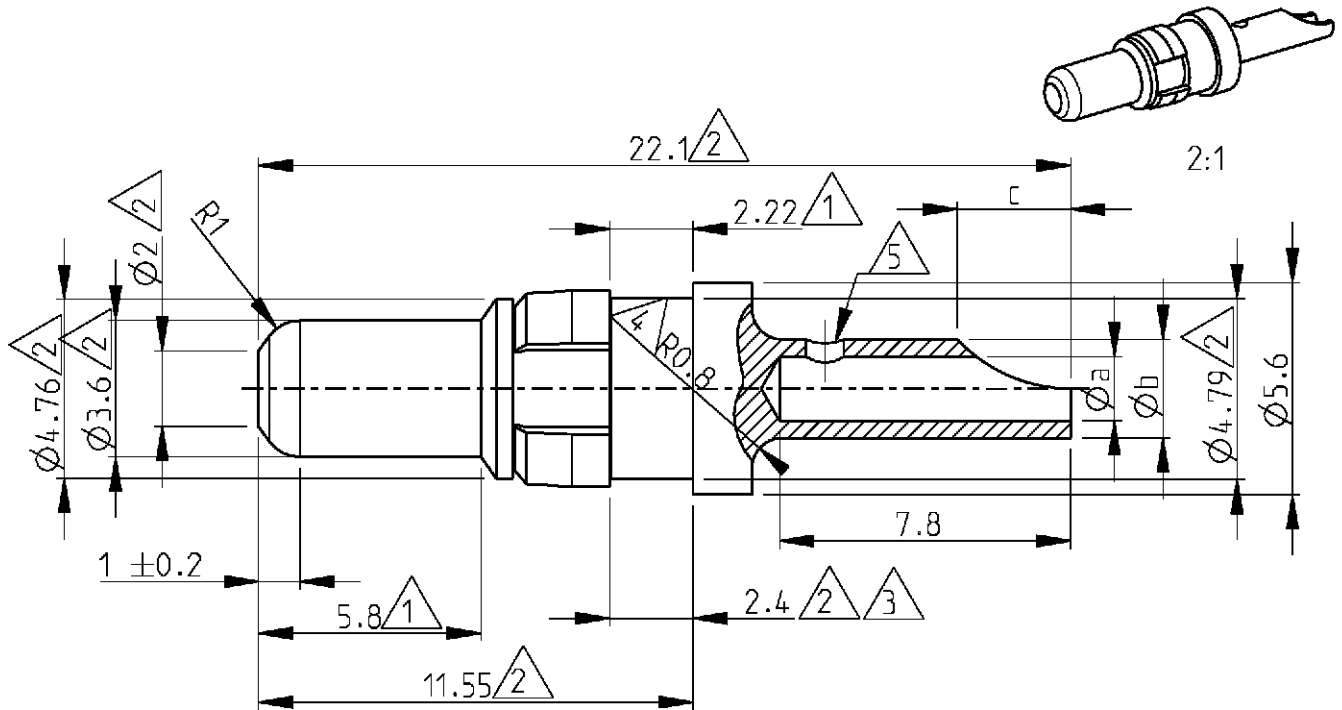

6) Application : DIN 41612 type M

- △5 Only on 1393589-5
- △4 Not applicable on 1393589-1
- △3 Measured with spring moved towards the mating face
- △2 max dimensions
- △1 Min dimensions

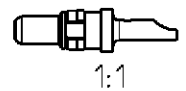

Cross reference							
Old part number	Tyco part number	Current	Øa	Øb	dim c	Material	Plating
C42334-A347-A93	1393589-5	10 A	1.7	2.6	3	Brass	1 µm Au or Pd in contact area
C42334-A347-A92	1393589-3	20 A	2.8	3.7	4	Brass	1 µm Au or Pd in contact area
C42334-A347-A91	1393589-1	40 A	4.8	5.6	5.2	Brass	1 µm Au or Pd in contact area

RELEASED FOR PUBLICATION 2000

THIS DRAWING IS UNPUBLISHED. BY TYCO ELECTRONICS CORPORATION. ALL RIGHTS RESERVED. © COPYRIGHT 2000

DIMENSIONS: mm	DWN B. Lenvain	19APR2001	MATERIAL	-	FINISH	-
	CHR K. Mattheeuws	19APR2001	Tyco Electronics Oostkamp - Belgium			
TOLERANCES UNLESS OTHERWISE SPECIFIED:	APVD R. Leeman	19APR2001				
0 PLC ±	PRODUCT SPEC	-	NAME High current plug with wire connection			
1 PLC ±	APPLICATION SPEC	-	SIZE	CAGE CODE	DRAWING NO	RESTRICTED TO
2 PLC ±	WEIGHT	-	A4	00779	©=1393589-5	-
3 PLC ±	CUSTOMER DRAWING	-	SCALE		SHEET	OF
4 PLC ±			5/1		1	1
ANGLES ±					REV	A