



**FEATURES:**

- Wide 2:1 Input Voltage Range
- High efficiency up to 91%
- 1500 VDC Isolation
- Over Current Protection
- Remote On/Off control
- Operating Temperature -40°C to +105°C
- Output Over Voltage protection
- Continuous Short Circuit Protection
- Input Under Voltage Protection
- Bare Part Meet CISPR32/EN55032 Class A



**Models**  
**Single output**

Model	Input Voltage (VDC)	Output Voltage (VDC)	Input Current max Full/No Load (mA)	Output Current max (mA)	Isolation (VDC)	Max Capacitive Load (uF)	Efficiency Typ. (%)
AM15C-1203S-NZ	9-18	3.3	1280/65	4000	1500	4700	88
AM15C-1205S-NZ	9-18	5	1421/65	3000	1500	4700	90
AM15C-1212S-NZ	9-18	12	1421/22	1250	1500	1000	90
AM15C-1215S-NZ	9-18	15	1405/22	1000	1500	820	91
AM15C-1224S-NZ	9-18	24	1405/22	625	1500	270	91
AM15C-2403S-NZ	18-36	3.3	647/50	4000	1500	4700	88
AM15C-2405S-NZ	18-36	5	711/50	3000	1500	4700	90
AM15C-2412S-NZ	18-36	12	711/15	1250	1500	1000	90
AM15C-2415S-NZ	18-36	15	703/15	1000	1500	820	91
AM15C-2424S-NZ	18-36	24	703/20	625	1500	270	91
AM15C-4803S-NZ	36-75	3.3	320/30	4000	1500	4700	88
AM15C-4805S-NZ	36-75	5	356/30	3000	1500	4700	90
AM15C-4812S-NZ	36-75	12	352/11	1250	1500	1000	91
AM15C-4815S-NZ	36-75	15	352/11	1000	1500	820	91
AM15C-4824S-NZ	36-75	24	352/11	625	1500	270	91

NOTE: All specifications in this datasheet are measured at an ambient temperature of 25°C, humidity<75%, nominal input voltage and at rated output load unless otherwise specified.

**Input Specifications**

Parameters	Nominal	Typical	Maximum	Units
Voltage range	12 Vin	9-18		VDC
	24 Vin	18-36		
	48 Vin	36-75		
Filter	Pi			
Absolute Maximum Rating (1s)	12 Vin		-0.7 – 25	VDC
	24 Vin		-0.7 – 50	
	48 Vin		-0.7 - 100	
Input reflected ripple current		30		mA
Input Under voltage protection	12 Vin	6.5		VDC
	24 Vin	15.5		
	48 Vin	30		
Startup time	Nominal input, resistive load		10	ms
Remote On/Off Control	On Off	3.5-12VDC or leave open 0-1.2VDC or connect to GND, idle current 2-7mA		

**Isolation Specifications**

Parameters	Conditions	Typical	Maximum	Units
Tested I/O voltage	60 sec, <1mA	1500		VDC
Resistance	500VDC		>1000	MOhm
Capacitance	I/O, 100KHz/0.1V	2000		pF

## Output Specifications

Parameters	Conditions	Typical	Maximum	Units	
Voltage accuracy	0% to 100% load	±1	±3	%	
Over voltage protection		110-160		% of Vout	
Over current protection		110-190		% of Iout	
Short Circuit protection	Continuous				
Short circuit restart	Auto-Recovery				
Line voltage regulation	Full load, LL to HL	±0.2	±0.5	% of Vin	
Load voltage regulation	5% to 100% load	±0.5	±1	%	
Temperature coefficient	100% load		±0.03	%/°C	
Ripple & Noise	20MHz Bandwidth, 5-100% load	50	100	mV p-p	
Transient recovery time	25% load step change	0.3	0.5	ms	
Transient recovery deviation	25% load step change	3.3/5V output	±3	±7	%
		Others	±3	±5	

## General Specifications

Parameters	Conditions	Typical	Maximum	Units
Switching frequency	100% load	3.3/5V output	300	KHz
		Others	270	
Operating temperature	See derating curve	3.3/5V output	-40 to +95	°C
		Others	-40 to +105	
Storage temperature		-55 to +125		°C
Maximum case temperature			105	°C
Cooling	Free air convection			
Humidity			95	% RH
Case material	Aluminum Alloy			
Weight	15			g
Dimensions (L x W x H)	1 x 1 x 0.46 inches		25.40 x 25.40 x 11.70 mm	
MTBF	>1,000,000 hours (MIL-HDBK -217F, Ground Benign, t <sub>a</sub> +25°C)			
Maximum soldering temperature	1.5mm from case for 10 sec		300	°C

## Safety Specifications

Parameters		
Standards	Designed to meet EN62368	
	CISPR32 / EN 55032, Class A, Class B with the recommended EMC circuit	
	Electrostatic Discharge Immunity	IEC 61000-4-2, Contact ±6KV, Air ±8KV, Criteria B
	RF, Electromagnetic Field Immunity	IEC 61000-4-3, 10V/m, Criteria A
	Electrical Fast Transient / Burst Immunity	IEC 61000-4-4, ±2KV with the recommended EMC circuit, Criteria A
	Surge Immunity	IEC 61000-4-5, L-L ±2KV with the recommended EMC circuit, Criteria B
	RF, Conducted Disturbance Immunity	IEC 61000-4-6, 3 Vrms, Criteria A

## Pin Out Specifications

Pin	Single
1	+V Input
2	-V Input
3	On/Off Control
4	+V Output
5	Trim
6	-V Output

### Dimensions

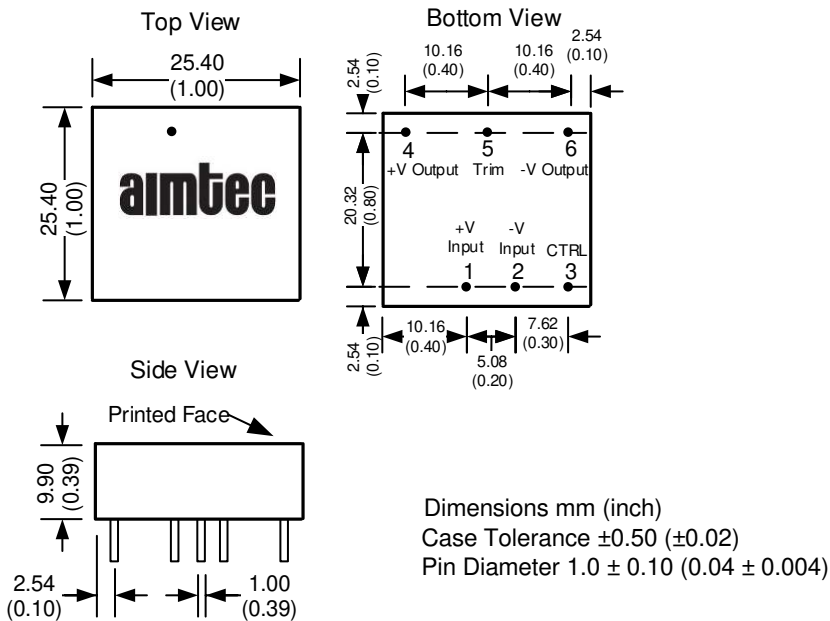

### Derating

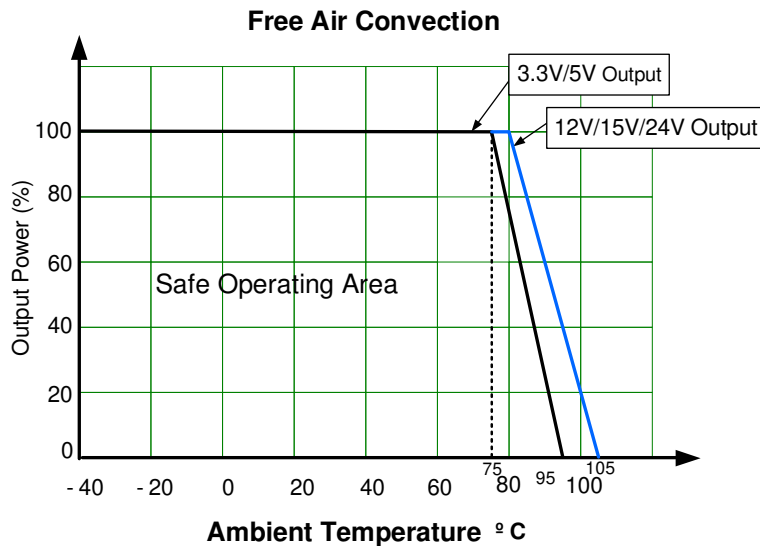

### Typical Application Circuits

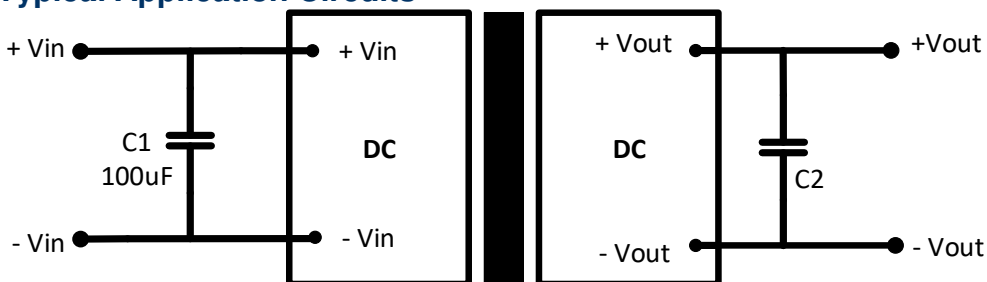

Model	3.3V/5V/12V/15V Vout	24V Vout
C2	100μF	47μF

### Recommended EMC Circuits

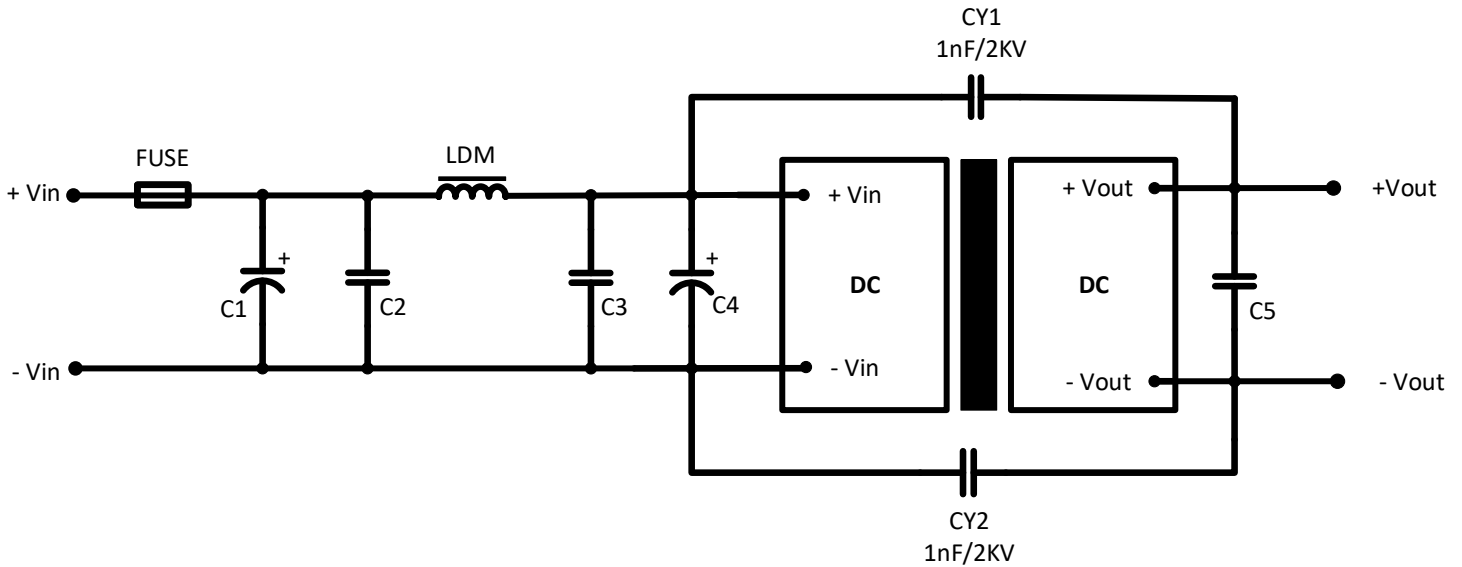

Model	12V/24V Vin	48V Vin
FUSE	Choose based on actual input current	
C1, C4	330 $\mu$ F/50V	330 $\mu$ F/100V
C2, C3	4.7 $\mu$ F/50V	4.7 $\mu$ F/100V
LDM	2.2 $\mu$ h/4A	2.2 $\mu$ H/2A
C5	Refer to the C2 in typical application circuit	

### Trimming

Output voltage can be externally trimmed by utilizing the methods as shown below

#### Fixed Resistor

#### Variable Potentiometer

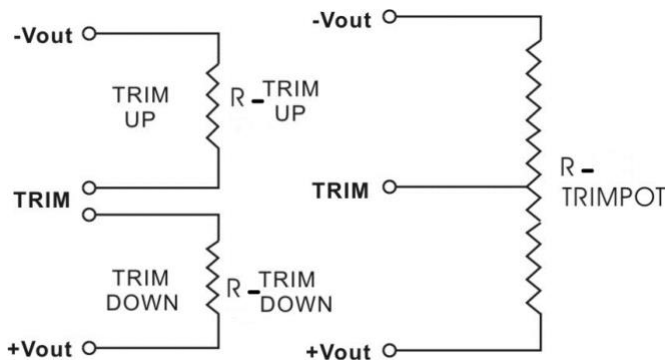

Leave open if not used.

### 3.3V output models

Trim down %	1	2	3	4	5	6	7	8	9	10
Vout (VDC)	3.267	3.234	3.201	3.168	3.135	3.102	3.069	3.036	3.003	2.97
Rt down (K $\Omega$ )	141.768	85.296	58.08	42.063	31.512	24.036	18.463	14.148	10.708	7.902
Trim up %	1	2	3	4	5	6	7	8	9	10
Vout (VDC)	3.333	3.366	3.399	3.432	3.465	3.498	3.531	3.564	3.597	3.63
Rt up (K $\Omega$ )	1280.954	143.632	69.487	42.576	28.667	20.17	14.442	10.318	7.208	4.778

5V output models

Trim down %	1	2	3	4	5	6	7	8	9	10
Vout (VDC)	4.95	4.9	4.85	4.8	4.75	4.7	4.65	4.6	4.55	4.5
Rt down (KΩ)	89.996	47.446	29.793	20.131	14.036	9.840	6.775	4.439	2.598	1.111
Trim up %	1	2	3	4	5	6	7	8	9	10
Vout (VDC)	5.05	5.1	5.15	5.2	5.25	5.3	5.35	5.4	5.45	5.5
Rt up (KΩ)	238.676	81.473	46.044	30.398	21.581	15.923	11.985	9.085	6.861	5.101

12V output models

Trim down %	1	2	3	4	5	6	7	8	9	10
Vout (VDC)	11.88	11.76	11.64	11.52	11.4	11.28	11.16	11.04	10.92	10.8
Rt down (KΩ)	493.692	299.052	210.127	159.185	126.173	103.042	85.932	72.764	62.316	53.823
Trim up %	1	2	3	4	5	6	7	8	9	10
Vout (VDC)	12.12	12.24	12.36	12.48	12.6	12.72	12.84	12.96	13.08	13.2
Rt up (KΩ)	704.035	156.520	81.479	51.675	35.677	25.695	18.874	13.917	10.152	7.195

15V output models

Trim down %	1	2	3	4	5	6	7	8	9	10
Vout (VDC)	14.85	14.7	14.55	14.4	14.25	14.1	13.95	13.8	13.65	13.5
Rt down (KΩ)	632.483	398.237	286.114	220.359	177.137	146.560	123.787	106.169	92.132	80.687
Trim up %	1	2	3	4	5	6	7	8	9	10
Vout (VDC)	15.15	15.3	15.45	15.6	15.75	15.9	16.05	16.2	16.35	16.5
Rt up (KΩ)	1457.699	190.174	94.242	58.954	40.616	29.381	21.791	16.321	12.190	8.961

24V output models

Trim down %	1	2	3	4	5	6	7	8	9	10
Vout (VDC)	23.76	23.52	23.28	23.04	22.8	22.56	22.32	22.08	21.84	21.6
Rt down (KΩ)	1284.000	789.923	563.667	433.904	349.754	290.763	247.115	213.514	186.847	165.170
Trim up %	1	2	3	4	5	6	7	8	9	10
Vout (VDC)	24.24	24.48	24.72	24.96	25.2	25.44	25.68	25.92	26.16	26.4
Rt up (KΩ)	814.689	177.714	92.138	58.264	40.107	28.788	21.057	15.440	11.176	7.827

**NOTE:** **1.** Datasheets are updated as needed and as such, specifications are subject to change without notice. Once printed or downloaded, datasheets are no longer controlled by Aimtec; refer to [www.aimtec.com](http://www.aimtec.com) for the most current product specifications. **2.** Product labels shown, including safety agency certifications on labels, may vary based on the date manufactured. **3.** Mechanical drawings and specifications are for reference only. **4.** All specifications are measured at an ambient temperature of 25°C, humidity < 75%, nominal input voltage and at rated output load unless otherwise specified. **5.** Aimtec may not have conducted destructive testing or chemical analysis on all internal components and chemicals at the time of publishing this document. CAS numbers and other limited information are considered proprietary and may not be available for release. **6.** This product is not designed for use in critical life support systems, equipment used in hazardous environments, nuclear control systems or other such applications which necessitate specific safety and regulatory standards other than the ones listed in this datasheet. **7.** Warranty is in accordance with Aimtec's standard Terms of Sale available at [www.aimtec.com](http://www.aimtec.com).