

P	LTR	DESCRIPTION	DATE	DWN	APVD
	A	INITIAL RELEASE	05APR2021	SR	CB

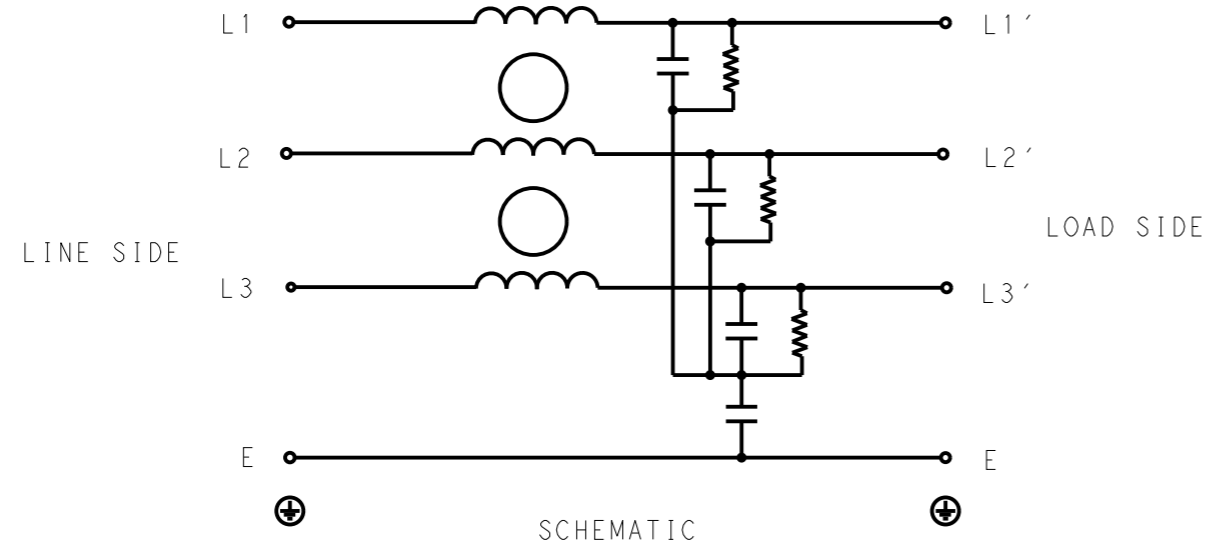

TYPICAL INSERTION LOSS
COMMON MODE 50/50Ω; DIFFERENTIAL MODE 50/50Ω

MHz	0.01	0.05	0.15	0.5	1	3	5	10	30
CM	2	3	4	11	20	40	35	35	45
DM	3	4	6	17	27	33	36	38	54

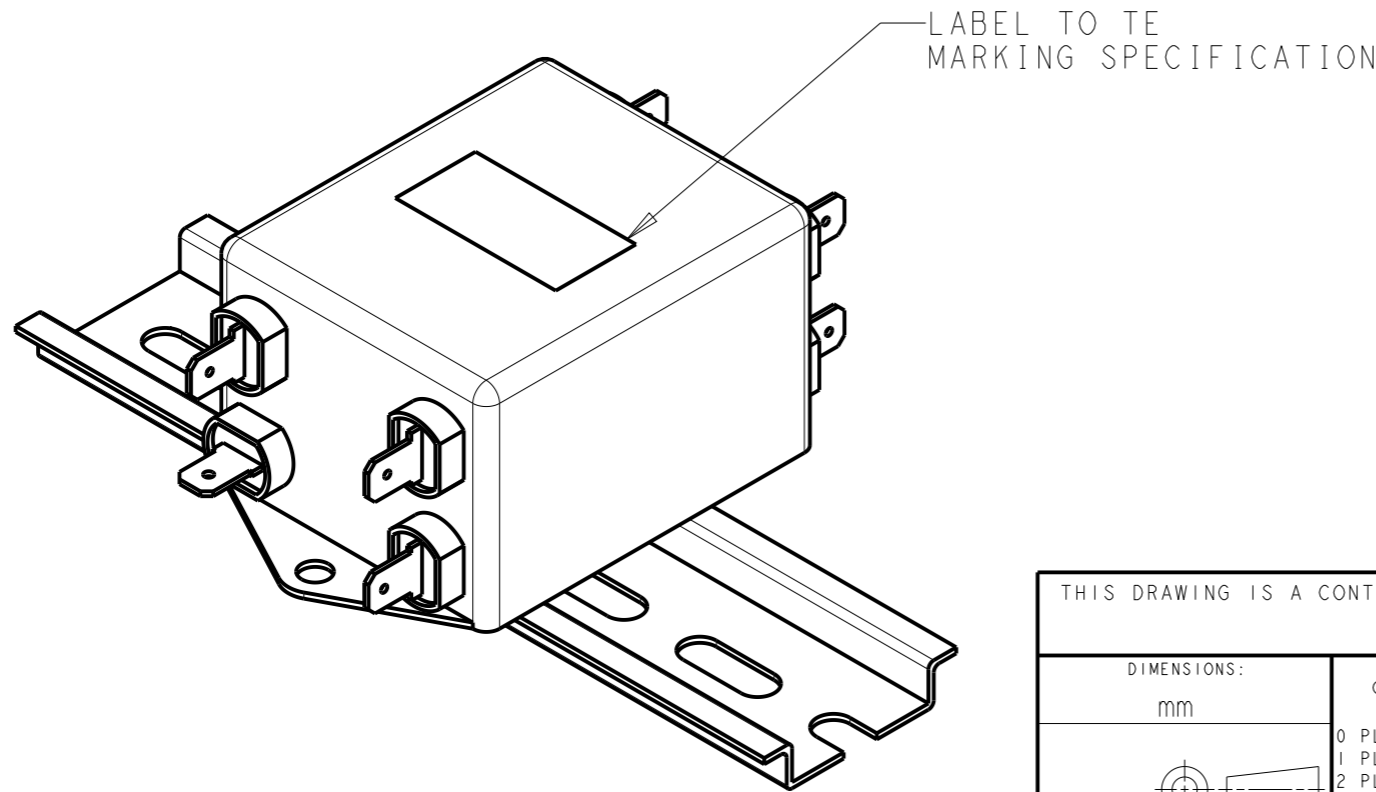

SAFETY ORGANIZATIONS

THIS FILTER WILL BE FORMALLY RECOGNIZED, CERTIFIED OR APPROVED BY THE LISTED AGENCY. THEREFORE, ALL TEST/REQUIREMENTS SPECIFIED IN THE LATEST REVISION OF THE FOLLOWING AGENCY STANDARDS WILL BE MET:

UL APPROVED 1A 520V 50Hz/60Hz 40°C
CSA PENDING 1A 520V 50Hz/60Hz 40°C

OPERATING SPECIFICATION

LINE CURRENT/VOLTAGE: 1A, 520VAC
LINE FREQUENCY: 50/60Hz

MAXIMUM LEAKAGE CURRENT: 3mA @ 230VAC, 50Hz

OPERATING AMBIENT TEMPERATURE RANGE @ RATED CURRENT: -25°C TO +40°C

IN AN AMBIENT, T_a, HIGHER THAN 40°C, THE MAXIMUM OPERATING CURRENT, I_o, IS AS FOLLOWS:

$$I_o = I_r \sqrt{\frac{85 - T_a}{45}}$$

RELIABILITY SPECIFICATIONS

STORAGE TEMPERATURE: -40°C TO +85°C
HUMIDITY: 21 DAYS @ 40°C AND 95% RH

TEST SPECIFICATIONS

INDUCTANCE, NOMINAL: 1 mH

CAPACITANCE @ 1kHz

LINE TO GROUND, NOMINAL: 18nF
LINE TO LINE, NOMINAL: 50nF

DISCHARGE RESISTOR

L/G I.R. 680KΩ 1W
L/L I.R. 2MΩ 1W
L/N I.R. XXX
N/G I.R. XXX

IR (NO DISCHARGE RESISTOR) 20°C, 50% RH AND 100VDC, MIN: 6MΩ

RECOMMENDED RECEIVING INSPECITON HIPOI

LINE TO GROUND FOR 1 MINUTE: 2856VDC
LINE TO LINE FOR 1 MINUTE: 2236VDC

FILTER APPROVAL

THE BEST WAY TO SELECT AND QUALIFY A FILTER IS FOR YOUR ENGINEERING TO TEST THE UNIT IN YOUR EQUIPMENT.

THIS DRAWING IS A CONTROLLED DOCUMENT.		DWN SUPREETH R 05APR2021				
DIMENSIONS: mm		CHK CHRIS BOLLE 05APR2021				
TOLERANCES UNLESS OTHERWISE SPECIFIED:		APVD CHRIS BOLLE 05APR2021				
0 PLC ±- 1 PLC ±0.5 2 PLC ±0.40 3 PLC ±0.130 4 PLC ±0.0500 ANGLES ±-		NAME POWER LINE FILTER FOR DIN 35 RAIL INSTALLATION 1KEBS1BFPDDM				
MATERIAL -	FINISH -	PRODUCT SPEC -	SIZE A300779	CAGE CODE C-6-1609965-3	DRAWING NO	RESTRICTED TO -
CUSTOMER DRAWING		WEIGHT -	SCALE 1:1	SHEET 1 OF 2	REV A	

REVISIONS

P	LTR	DESCRIPTION	DATE	DWN	APVD
		SEE SHEET 1			

NOTE 1 GROUND CONNECTION:
FOR ELECTRICAL SAFETY AND FILTER PERFORMANCE
UNIT MUST HAVE A GOOD GROUND CONNECTION.

NOTE 2 INPUT OUTPUT CONNECTION TERMINAL
AWG SIZE: XXX
WIRE SECTION: XXX

NOTE 3 SUPPLIED WITH DIN RAIL BRACKET

NOTE 4 DRAWING SHOWS DIN RAIL FOR
REFERENCE ONLY.

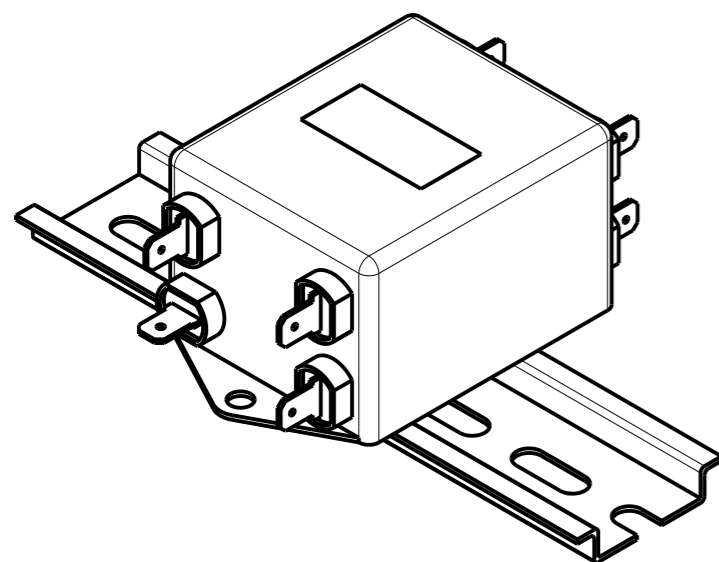
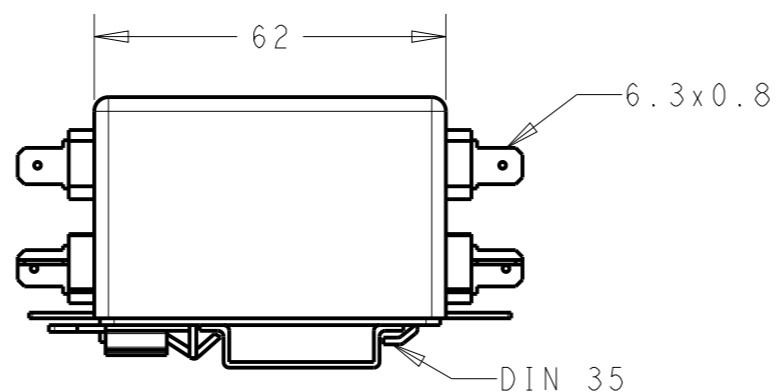
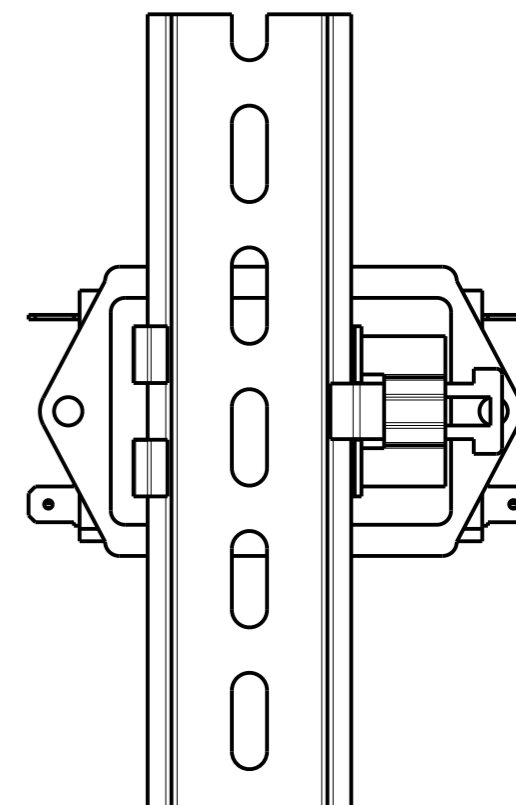
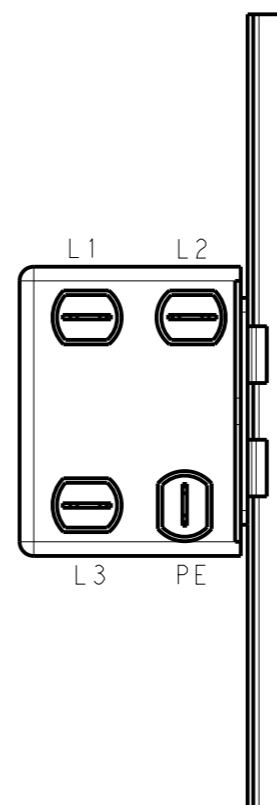
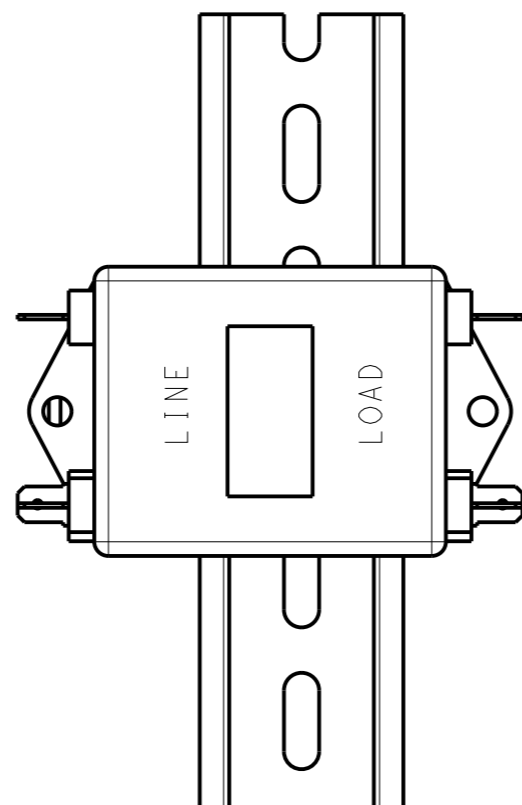
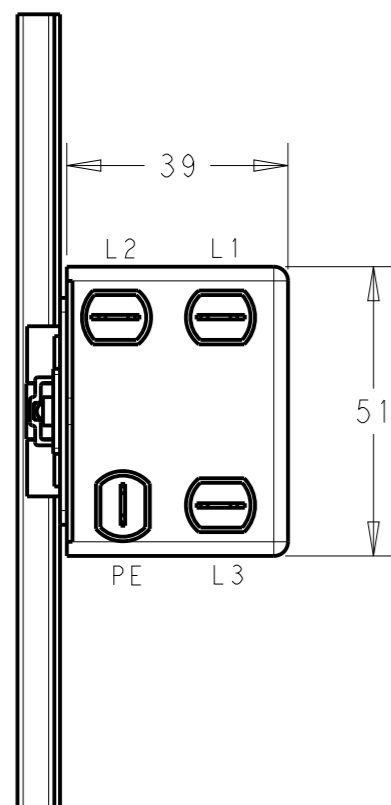
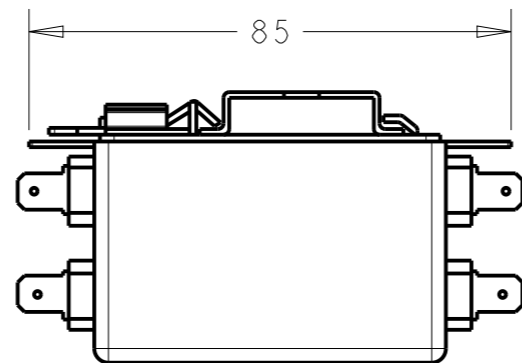

THIS DRAWING IS A CONTROLLED DOCUMENT.

DIMENSIONS:		TOLERANCES UNLESS OTHERWISE SPECIFIED:	
mm			
		0 PLC	±0.5
		1 PLC	±0.40
		2 PLC	±0.130
		3 PLC	±0.0500
		4 PLC	±
		ANGLES	±
MATERIAL	-	FINISH	-
	-		-

DWN	SUPREETH R	05APR2021
CHK	CHRIS BOLLE	05APR2021
APVD	CHRIS BOLLE	05APR2021
PRODUCT SPEC	-	
APPLICATION SPEC	-	
WEIGHT	-	
CUSTOMER DRAWING		

		NAME		RESTRICTED TO
		POWER LINE FILTER FOR DIN 35 RAIL INSTALLATION 1KEBS1BFPDDM		
SIZE	CAGE CODE	DRAWING NO		
A3	00779	C-6-1609965-3		
SCALE		SHEET	OF	REV
3:4		2	2	A