

Evaluation Board for 16-Lead TSSOP Devices in the **Switches and Multiplexers Portfolio**

FEATURES

- 16-lead TSSOP evaluation board
- Clamp allows the main device to be easily changed
- Gold pin connectors allow the addition of passive components
- SMB connectors for the input/output of signals
- Additional space on-board to allow for prototyping

EVALUATION KIT CONTENTS

- EVAL-16TSSOPEBZ evaluation board

ONLINE RESOURCES

Documents Needed

- Data sheet of the device being evaluated
- EVAL-16TSSOPEBZ user guide

EQUIPMENT NEEDED

- Device being evaluated
- DC voltage source
- Analog signal source
- Method to measure voltage, such as a digital multimeter (DMM)

GENERAL DESCRIPTION

The EVAL-16TSSOPEBZ evaluation board evaluates 16-lead TSSOP devices in the **Switches and Multiplexers Portfolio** that are purchased separately. A clamp is supplied with the EVAL-16TSSOPEBZ to secure a 16-lead TSSOP device to the evaluation board without the need for soldering, making the board reusable for multiple devices.

Figure 1 shows the EVAL-16TSSOPEBZ evaluation board. A 16-lead TSSOP device can be clamped or soldered to the center of the evaluation board. Each pin of the device has a corresponding link from K1 to K16 that can be set to either VDD or GND. A wire screw terminal supplies VDD and GND. SMB connectors on the board allow additional external signals to be supplied to the device. In addition, there is space available at the top of the board for prototyping.

Full specifications of the device under test (DUT) are available in the corresponding product data sheet, which should be consulted in conjunction with this user guide when using the evaluation board.

EVAL-16TSSOPEBZ EVALUATION BOARD PHOTOGRAPH

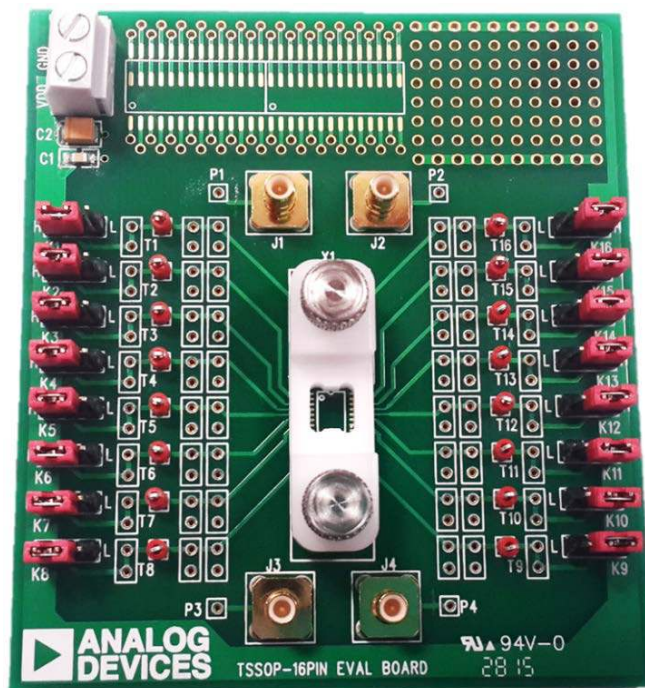

Figure 1.

TABLE OF CONTENTS

Features	1	Power Supply.....	3
Evaluation Kit Contents.....	1	Link headers.....	3
Online Resources.....	1	SMB Connectors.....	3
Equipment Needed.....	1	Input Signal Traces.....	3
General Description	1	Evaluation Board Schematic and Artwork.....	4
EVAL-16TSSOPEBZ Evaluation Board Photograph	1	Ordering Information.....	7
Revision History	2	Bill of Materials.....	7
Evaluation Board Hardware.....	3		

REVISION HISTORY

5/16—Revision 0: Initial Version

EVALUATION BOARD HARDWARE

POWER SUPPLY

Connector J5 supplies the VDD and GND supplies to the board. These supplies can be selected for each pin of the device by setting the link headers to either VDD or GND. When a VSS supply is needed, apply the voltage directly to the VSS or GND pin of the device by removing the corresponding link.

LINK HEADERS

The link headers supply the DUT with either VDD or GND. The headers are designated K1 to K16 with the number corresponding to the pin number of the device. Table 1 summarizes the link headers and how they function on the evaluation board.

Table 1. Link Header Descriptions

Label	Position	Description
K1to K16	H	VDD
	L	GND

SMB CONNECTORS

There are four SMB connectors on evaluation board, J1 to J4. When an SMB cable is connected to one of these connectors, the input signal becomes available on the corresponding P1 to P4 port. Apply this signal to the relevant pin of the device by forming a connection from P1 to P4 to a gold pin connector found on the relevant trace.

INPUT SIGNAL TRACES

Each trace includes three sets of gold pin connectors, two sets that can place a load on the signal path to ground and another set that is in series with the signal path. The three sets of gold pin connectors can create a simple resistor capacitor (RC) filter.

EVALUATION BOARD SCHEMATIC AND ARTWORK

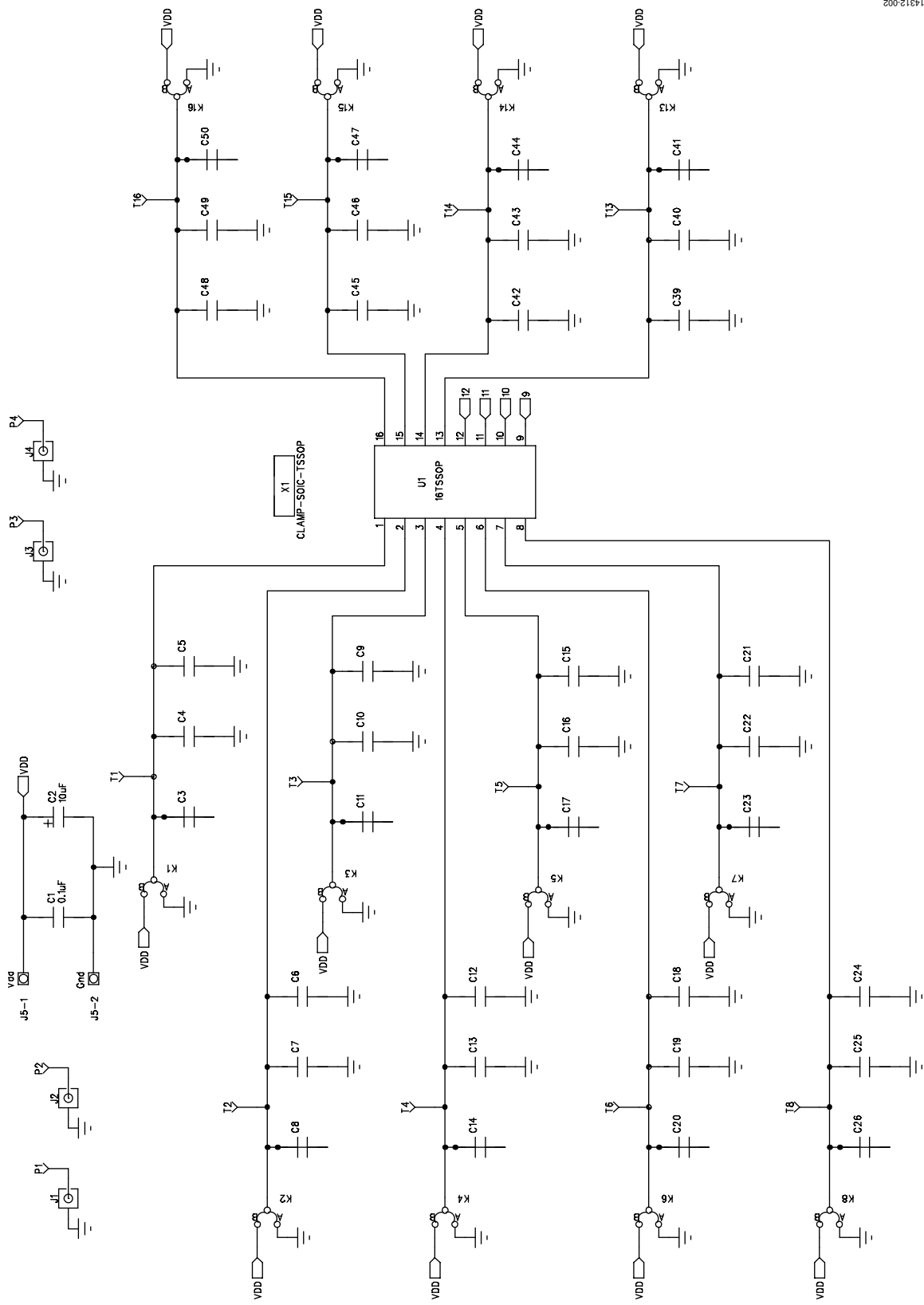

14912.002

Figure 2. EVAL-16TSSOPEBZ Evaluation Board Schematic

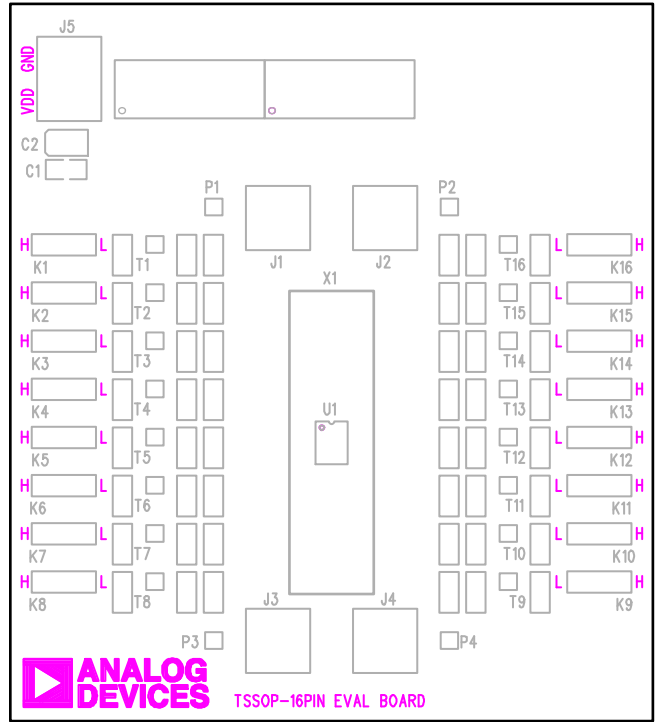

Figure 3. EVAL-16TSSOPEBZ Evaluation Board Silkscreen

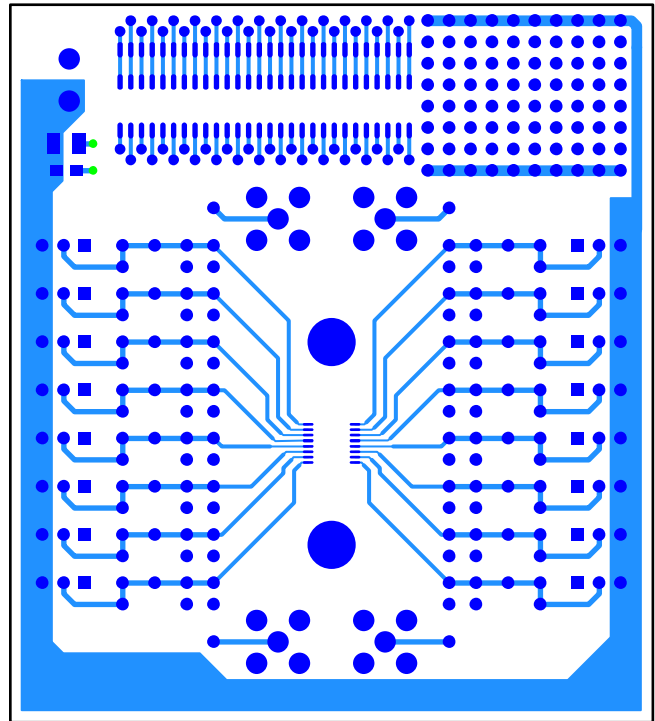

Figure 4. EVAL-16TSSOPEBZ Evaluation Board Top Layer

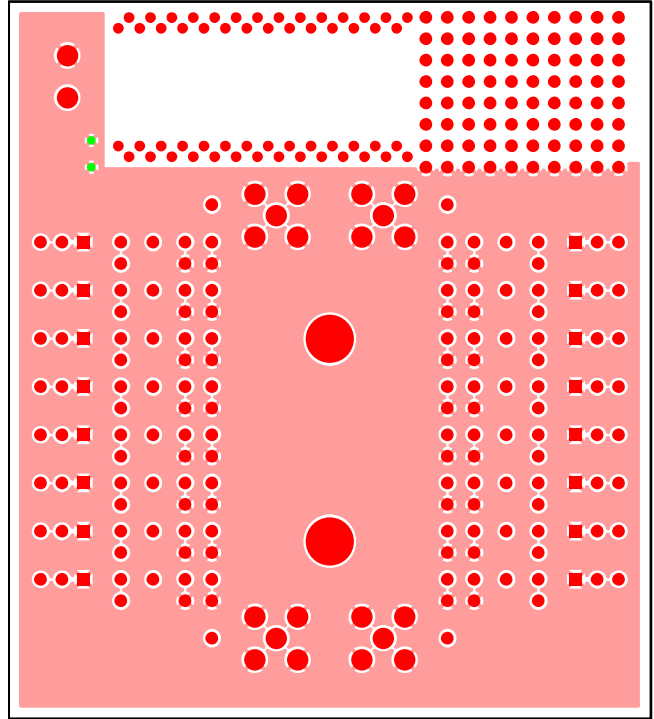

Figure 5. EVAL-16TSSOPEBZ Evaluation Board Bottom Layer

ORDERING INFORMATION

BILL OF MATERIALS

Table 2.

Reference Designator	Description	Part Number	Stock Code
C1	0.1 µF, 50 V, X7R, ceramic capacitor	GRM21BR71H104KA01L	FEC 2408531
C2	10 µF, 10 V tantalum capacitor	TAJB106K016RNJ	FEC 498-737
C3 to C50	Harwin subminiature sockets (2)	H3153-01	FEC 2120079
J1 to J4	SMB sockets	1206013	FEC 310-682
J5	2-pin terminal block (5 mm pitch)	KRM 02	FEC 151-785
K1 to K16	Jumper blocks using 3-pin SIP header	M20-9990345 and M7566-05	FEC 512-047 and 150-411
P1 to P4	Harwin subminiature sockets (2)	H3153-01	FEC 2120079
T1 to T16	Test points	20-313137	FEC 240-345



ESD Caution

ESD (electrostatic discharge) sensitive device. Charged devices and circuit boards can discharge without detection. Although this product features patented or proprietary protection circuitry, damage may occur on devices subjected to high energy ESD. Therefore, proper ESD precautions should be taken to avoid performance degradation or loss of functionality.

Legal Terms and Conditions

By using the evaluation board discussed herein (together with any tools, components documentation or support materials, the "Evaluation Board"), you are agreeing to be bound by the terms and conditions set forth below ("Agreement") unless you have purchased the Evaluation Board, in which case the Analog Devices Standard Terms and Conditions of Sale shall govern. Do not use the Evaluation Board until you have read and agreed to the Agreement. Your use of the Evaluation Board shall signify your acceptance of the Agreement. This Agreement is made by and between you ("Customer") and Analog Devices, Inc. ("ADI"), with its principal place of business at One Technology Way, Norwood, MA 02062, USA. Subject to the terms and conditions of the Agreement, ADI hereby grants to Customer a free, limited, personal, temporary, non-exclusive, non-sublicensable, non-transferable license to use the Evaluation Board FOR EVALUATION PURPOSES ONLY. Customer understands and agrees that the Evaluation Board is provided for the sole and exclusive purpose referenced above, and agrees not to use the Evaluation Board for any other purpose. Furthermore, the license granted is expressly made subject to the following additional limitations: Customer shall not (i) rent, lease, display, sell, transfer, assign, sublicense, or distribute the Evaluation Board; and (ii) permit any Third Party to access the Evaluation Board. As used herein, the term "Third Party" includes any entity other than ADI, Customer, their employees, affiliates and in-house consultants. The Evaluation Board is NOT sold to Customer; all rights not expressly granted herein, including ownership of the Evaluation Board, are reserved by ADI. CONFIDENTIALITY. This Agreement and the Evaluation Board shall all be considered the confidential and proprietary information of ADI. Customer may not disclose or transfer any portion of the Evaluation Board to any other party for any reason. Upon discontinuation of use of the Evaluation Board or termination of this Agreement, Customer agrees to promptly return the Evaluation Board to ADI. ADDITIONAL RESTRICTIONS. Customer may not disassemble, decompile or reverse engineer chips on the Evaluation Board. Customer shall inform ADI of any occurred damages or any modifications or alterations it makes to the Evaluation Board, including but not limited to soldering or any other activity that affects the material content of the Evaluation Board. Modifications to the Evaluation Board must comply with applicable law, including but not limited to the RoHS Directive. TERMINATION. ADI may terminate this Agreement at any time upon giving written notice to Customer. Customer agrees to return to ADI the Evaluation Board at that time. LIMITATION OF LIABILITY. THE EVALUATION BOARD PROVIDED HEREUNDER IS PROVIDED "AS IS" AND ADI MAKES NO WARRANTIES OR REPRESENTATIONS OF ANY KIND WITH RESPECT TO IT. ADI SPECIFICALLY DISCLAIMS ANY REPRESENTATIONS, ENDORSEMENTS, GUARANTEES, OR WARRANTIES, EXPRESS OR IMPLIED, RELATED TO THE EVALUATION BOARD INCLUDING, BUT NOT LIMITED TO, THE IMPLIED WARRANTY OF MERCHANTABILITY, TITLE, FITNESS FOR A PARTICULAR PURPOSE OR NON-INFRINGEMENT OF INTELLECTUAL PROPERTY RIGHTS. IN NO EVENT WILL ADI AND ITS LICENSORS BE LIABLE FOR ANY INCIDENTAL, SPECIAL, INDIRECT, OR CONSEQUENTIAL DAMAGES RESULTING FROM CUSTOMER'S POSSESSION OR USE OF THE EVALUATION BOARD, INCLUDING BUT NOT LIMITED TO LOST PROFITS, DELAY COSTS, LABOR COSTS OR LOSS OF GOODWILL. ADI'S TOTAL LIABILITY FROM ANY AND ALL CAUSES SHALL BE LIMITED TO THE AMOUNT OF ONE HUNDRED US DOLLARS (\$100.00). EXPORT. Customer agrees that it will not directly or indirectly export the Evaluation Board to another country, and that it will comply with all applicable United States federal laws and regulations relating to exports. GOVERNING LAW. This Agreement shall be governed by and construed in accordance with the substantive laws of the Commonwealth of Massachusetts (excluding conflict of law rules). Any legal action regarding this Agreement will be heard in the state or federal courts having jurisdiction in Suffolk County, Massachusetts, and Customer hereby submits to the personal jurisdiction and venue of such courts. The United Nations Convention on Contracts for the International Sale of Goods shall not apply to this Agreement and is expressly disclaimed.

