

This Quick-Reference Guide is a summary of information for the installation of die assemblies listed on the other side of this guide. Detailed information for installation and crimping procedures is included in TE Customer Manual 409-32027.

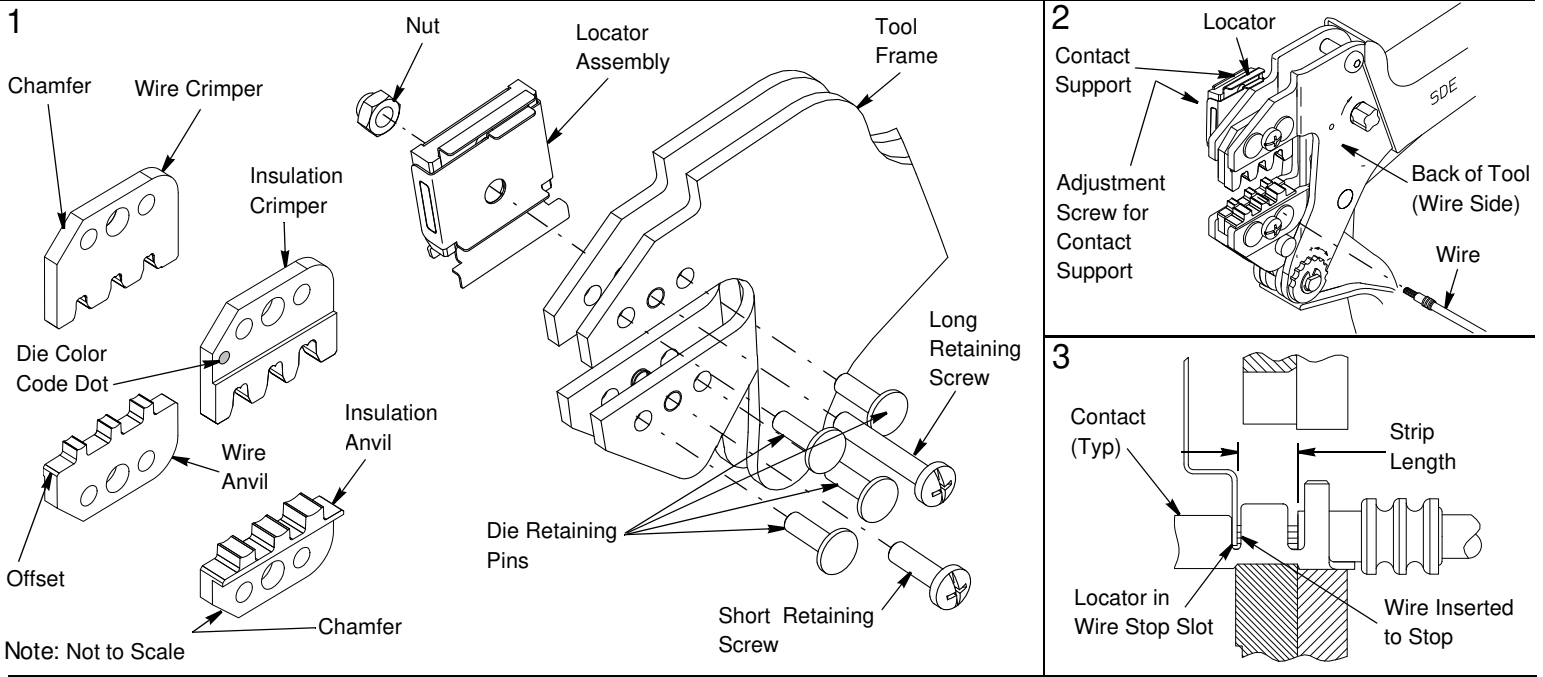

This Quick-Reference Guide is a summary of information for the installation of die assemblies listed on the other side of this guide. Detailed information for installation and crimping procedures is included in TE Customer Manual 409-32027.

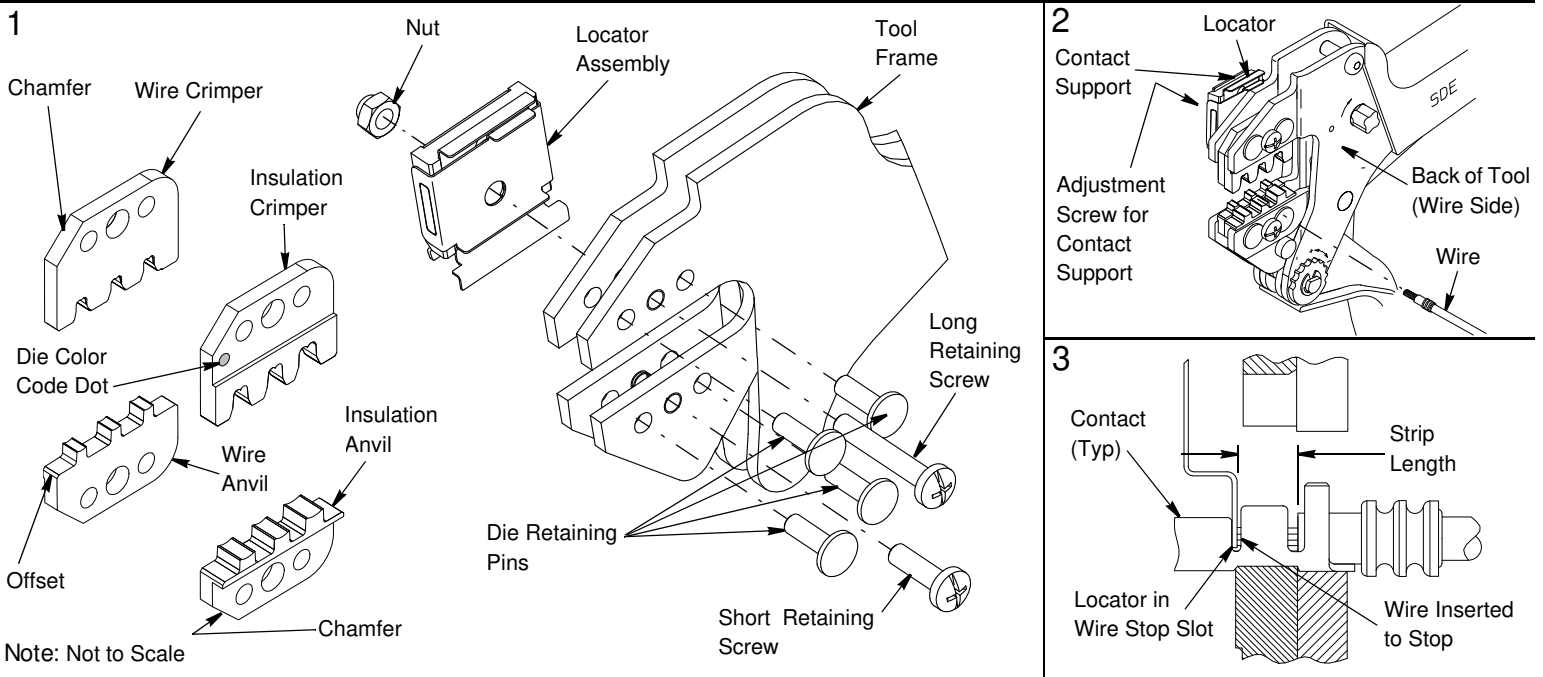

PACCAR QUICK-REFERENCE GUIDE

CONTACT		WIRE			SEAL		DIE ASSEMBLY			
DESCRIPTION	TE PART NUMBER	WIRE SIZE (AWG)	INSULATION DIA RANGE mm [in.]	STRIP LENGTH mm [in.]	PART NUMBER	SEAL COLOR	PART NUMBER	DIE COLOR CODE DOT	CRIMP CAVITY	WIRE CRIMP HEIGHT ±0.05 [.0020]
AMP MCP 1.5K Recept	1241381-1	20 TXL	1.66-1.90 [.065-.075]	4.0 ±0.3 [.157 ±.012]	963530-1	GREY	2217281-1	RED	B	0.98 [.0386]
		20 GXL	2.06-2.40 [.081-.094]	4.0 ±0.3 [.157 ±.012]	964972-1	YELLOW	2217281-1	RED	B	0.98 [.0386]
		18TXL	1.96-2.20 [.077-.087]	4.0 ±0.3 [.157 ±.012]	964972-1	YELLOW	2217281-1	RED	C	1.08 [.0425]
AMP MCP 2.8 Recept	1-968875-1	20 TXL	1.66-1.90 [.065-.075]	4.5 ±0.3 [.177 ±.012]	828904-2	BLUE	2217281-1	RED	A	1.09 [.0429]
		18TXL	1.96-2.20 [.077-.087]	4.5 ±0.3 [.177 ±.012]	828904-2	BLUE	2217282-1	GREEN	A	1.18 [.0465]
		18GXL	2.16-2.50 [.085-.098]	4.5 ±0.3 [.177 ±.012]	828905-1	WHITE	2217282-1	GREEN	A	1.18 [.0465]
AMP MCP 2.8 Recept	1-968876-1	16 TXL	2.16-2.40 [.085-.094]	5.0 ±0.3 [.197 ±.012]	828905-1	WHITE	2217282-1	GREEN	B	1.38 [.0543]
		16 GXL	2.56-2.90 [.101-.114]	5.0 ±0.3 [.197 ±.012]	828905-1	WHITE	2217282-1	GREEN	B	1.38 [.0543]
		14 TXL	2.46-2.70 [.097-.106]	5.0 ±0.3 [.197 ±.012]	828905-1	WHITE	2217282-1	GREEN	C	1.59 [.0626]
AMP MCP 1.5K Tab	964270-2	20 TXL	1.66-1.90 [.065-.075]	4.0 ±0.3 [.157 ±.012]	963530-1	GREY	2217280-1	WHITE	B	1.09 [.0429]
		20 GXL	2.06-2.40 [.081-.094]	4.0 ±0.3 [.157 ±.012]	964972-1	YELLOW	2217280-1	WHITE	B	1.09 [.0429]
		18 TXL	1.96-2.20 [.077-.087]	4.0 ±0.3 [.157 ±.012]	964972-1	YELLOW	2217280-1	WHITE	C	1.18 [.0465]
AMP MCP 2.8 Tab	1-963748-1	20 TXL	1.66-1.90 [.065-.075]	4.5 ±0.3 [.177 ±.012]	828904-2	BLUE	2217280-1	WHITE	A	1.12 [.0441]
		18 TXL	1.96-2.20 [.077-.087]	4.5 ±0.3 [.177 ±.012]	828904-2	BLUE	2217283-1	YELLOW	A	1.21 [.0476]
		18 GXL	2.16-2.50 [.085-.098]	4.5 ±0.3 [.177 ±.012]	828905-1	WHITE	2217283-1	YELLOW	A	1.21 [.0476]
AMP MCP 2.8 Tab	1-963749-1	16 TXL	2.16-2.40 [.085-.094]	5.0 ±0.3 [.197 ±.012]	828905-1	WHITE	2217283-1	YELLOW	B	1.38 [.0543]
		16 GXL	2.56-2.90 [.101-.114]	5.0 ±0.3 [.197 ±.012]	828905-1	WHITE	2217283-1	YELLOW	B	1.38 [.0543]
		14 TXL	2.46-2.70 [.097-.106]	5.0 ±0.3 [.197 ±.012]	828905-1	WHITE	2217283-1	YELLOW	C	1.58 [.0622]
AMP MCP 2.8 Tab	1-963749-1	14 GXL	2.86-3.20 [.113-.126]	5.0 ±0.3 [.197 ±.012]	282536-1	GREY	2217283-1	YELLOW	C	1.58 [.0622]
AMP MCP 1.5K Recept	1418885-1	16 TXL	2.16-2.40 [.085-.094]	4.0 ±0.3 [.157 ±.012]	964972-1	YELLOW	2217285-1	ORANGE	A	1.24 [.0488]
AMP MCP 1.5K Tab	1703279-2	16 TXL	2.16-2.40 [.085-.094]	4.0 ±0.3 [.157 ±.012]	964972-1	YELLOW	2217285-1	ORANGE	B	1.34 [.0528]
		16 TXL	2.16-2.40 [.085-.094]	4.0 ±0.3 [.157 ±.012]	2112323-1†	ORANGE†	2217285-1	ORANGE	B	1.34 [.0528]
AMP MCP 2.8 Recept	1-1719505-1	12 TXL	3.02-3.30 [.119-.130]	5.6 ±0.3 [.220 ±.012]	282536-1	GREY	2217284-1	BLUE	A	1.88 [.0740]
AMP MCP 2.8 Tab	1-1719503-1	12 TXL	3.02-3.30 [.119-.130]	5.6 ±0.3 [.220 ±.012]	282536-1	GREY	2217284-1	BLUE	A	1.88 [.0740]

†Use ONLY with AMP MCP Sealed 62-Way Connector in 1.6 Series Cavities.

PACCAR is a trademark.

PACCAR QUICK-REFERENCE GUIDE

CONTACT		WIRE			SEAL		DIE ASSEMBLY			
DESCRIPTION	TE PART NUMBER	WIRE SIZE (AWG)	INSULATION DIA RANGE mm [in.]	STRIP LENGTH mm [in.]	PART NUMBER	SEAL COLOR	PART NUMBER	DIE COLOR CODE DOT	CRIMP CAVITY	WIRE CRIMP HEIGHT ±0.05 [.0020]
AMP MCP 1.5K Recept	1241381-1	20 TXL	1.66-1.90 [.065-.075]	4.0 ±0.3 [.157 ±.012]	963530-1	GREY	2217281-1	RED	B	0.98 [.0386]
		20 GXL	2.06-2.40 [.081-.094]	4.0 ±0.3 [.157 ±.012]	964972-1	YELLOW	2217281-1	RED	B	0.98 [.0386]
		18TXL	1.96-2.20 [.077-.087]	4.0 ±0.3 [.157 ±.012]	964972-1	YELLOW	2217281-1	RED	C	1.08 [.0425]
AMP MCP 2.8 Recept	1-968875-1	20 TXL	1.66-1.90 [.065-.075]	4.5 ±0.3 [.177 ±.012]	828904-2	BLUE	2217281-1	RED	A	1.09 [.0429]
		18TXL	1.96-2.20 [.077-.087]	4.5 ±0.3 [.177 ±.012]	828904-2	BLUE	2217282-1	GREEN	A	1.18 [.0465]
		18GXL	2.16-2.50 [.085-.098]	4.5 ±0.3 [.177 ±.012]	828905-1	WHITE	2217282-1	GREEN	A	1.18 [.0465]
AMP MCP 2.8 Recept	1-968876-1	16 TXL	2.16-2.40 [.085-.094]	5.0 ±0.3 [.197 ±.012]	828905-1	WHITE	2217282-1	GREEN	B	1.38 [.0543]
		16 GXL	2.56-2.90 [.101-.114]	5.0 ±0.3 [.197 ±.012]	828905-1	WHITE	2217282-1	GREEN	B	1.38 [.0543]
		14 TXL	2.46-2.70 [.097-.106]	5.0 ±0.3 [.197 ±.012]	828905-1	WHITE	2217282-1	GREEN	C	1.59 [.0626]
AMP MCP 1.5K Tab	964270-2	20 TXL	1.66-1.90 [.065-.075]	4.0 ±0.3 [.157 ±.012]	963530-1	GREY	2217280-1	WHITE	B	1.09 [.0429]
		20 GXL	2.06-2.40 [.081-.094]	4.0 ±0.3 [.157 ±.012]	964972-1	YELLOW	2217280-1	WHITE	B	1.09 [.0429]
		18 TXL	1.96-2.20 [.077-.087]	4.0 ±0.3 [.157 ±.012]	964972-1	YELLOW	2217280-1	WHITE	C	1.18 [.0465]
AMP MCP 2.8 Tab	1-963748-1	20 TXL	1.66-1.90 [.065-.075]	4.5 ±0.3 [.177 ±.012]	828904-2	BLUE	2217280-1	WHITE	A	1.12 [.0441]
		18 TXL	1.96-2.20 [.077-.087]	4.5 ±0.3 [.177 ±.012]	828904-2	BLUE	2217283-1	YELLOW	A	1.21 [.0476]
		18 GXL	2.16-2.50 [.085-.098]	4.5 ±0.3 [.177 ±.012]	828905-1	WHITE	2217283-1	YELLOW	A	1.21 [.0476]
AMP MCP 2.8 Tab	1-963749-1	16 TXL	2.16-2.40 [.085-.094]	5.0 ±0.3 [.197 ±.012]	828905-1	WHITE	2217283-1	YELLOW	B	1.38 [.0543]
		16 GXL	2.56-2.90 [.101-.114]	5.0 ±0.3 [.197 ±.012]	828905-1	WHITE	2217283-1	YELLOW	B	1.38 [.0543]
		14 TXL	2.46-2.70 [.097-.106]	5.0 ±0.3 [.197 ±.012]	828905-1	WHITE	2217283-1	YELLOW	C	1.58 [.0622]
AMP MCP 2.8 Tab	1-963749-1	14 GXL	2.86-3.20 [.113-.126]	5.0 ±0.3 [.197 ±.012]	282536-1	GREY	2217283-1	YELLOW	C	1.58 [.0622]
AMP MCP 1.5K Recept	1418885-1	16 TXL	2.16-2.40 [.085-.094]	4.0 ±0.3 [.157 ±.012]	964972-1	YELLOW	2217285-1	ORANGE	A	1.24 [.0488]
AMP MCP 1.5K Tab	1703279-2	16 TXL	2.16-2.40 [.085-.094]	4.0 ±0.3 [.157 ±.012]	964972-1	YELLOW	2217285-1	ORANGE	B	1.34 [.0528]
		16 TXL	2.16-2.40 [.085-.094]	4.0 ±0.3 [.157 ±.012]	2112323-1†	ORANGE†	2217285-1	ORANGE	B	1.34 [.0528]
AMP MCP 2.8 Recept	1-1719505-1	12 TXL	3.02-3.30 [.119-.130]	5.6 ±0.3 [.220 ±.012]	282536-1	GREY	2217284-1	BLUE	A	1.88 [.0740]
AMP MCP 2.8 Tab	1-1719503-1	12 TXL	3.02-3.30 [.119-.130]	5.6 ±0.3 [.220 ±.012]	282536-1	GREY	2217284-1	BLUE	A	1.88 [.0740]

†Use ONLY with AMP MCP Sealed 62-Way Connector in 1.6 Series Cavities.

PACCAR is a trademark.