



Description

- ATmega2560, Arduino Compatible Microcontroller
- Very small size: 53x53mm (in case)
- Integrated Sensors (Gyroscope / Accelerometer / Magnetometer / Barometer)
- Built-in GPS Module with External Antenna
- Easy Connection for Motor Controller and Radio System
- Semi-transparent case to view LED status
- MultiWii software compatible
- Expansion ports for experimentation (I2C, UART, GPIO)

The Lynxmotion Quadrino Nano Drone/UAV Flight Controller (with GPS) was created as a collaboration between FlyingEinstein and the Lynxmotion team. ([see press release](#)) It was designed to be one of the smallest possible flight controllers on the market, The board includes many additional features normally reserved to much more expensive flight controllers.

The Quadrino is the only MultiWii controller with the easy to use Firmware Config software eliminating the need for the Arduino Development Environment. This easy wizard-like application will lead you through the entire process while providing lots of documentation on the various options and parameters you have available. When you are done selecting your options this tool will build and upload your custom firmware directly to your Quadrino board. It will also install the MultiWiiConf config GUI for you.



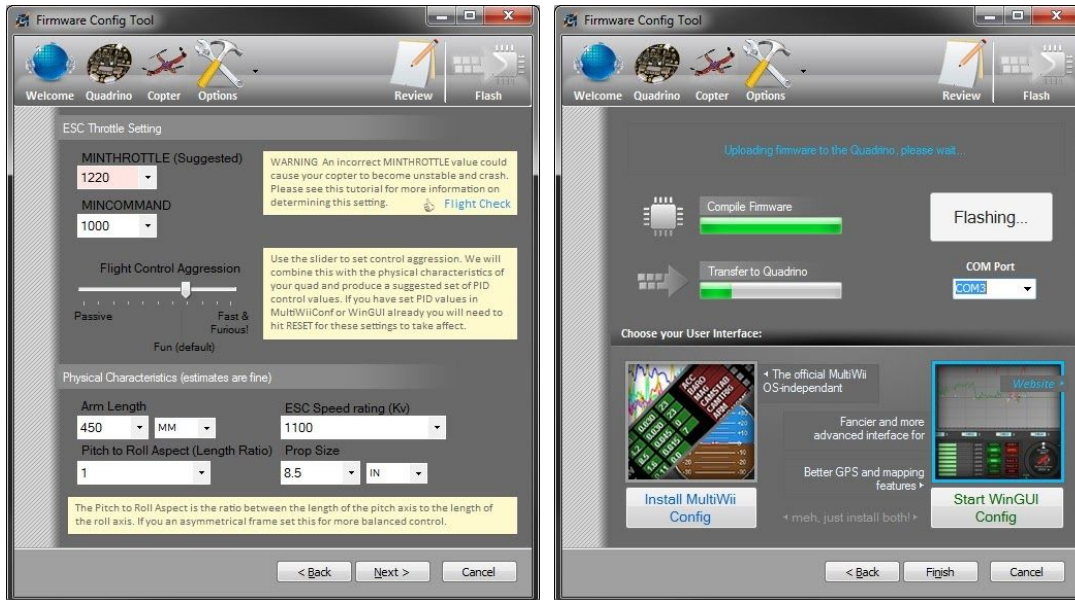

With the addition of the Quadriino Nano to the Lynxmotion UAV lineup, we will be able to provide a sturdy platform in terms of hardware and software to anyone looking to jump in the UAV world. Build-in sensors as well as GPS give the user full options available via the MultiWii software, and also allows for custom modification of the code and integration of additional features and products that weren't possible before.

Specifications

- ATmega 2560 (256Kb flash @ 16MHz) Processor
- Compact, six layer PCB design
- Mounting options: 3M double sided adhesive foam or screws
- Vibration dampening mounted PCB
- Arduino bootloader making DIY / hacking projects possible
- Onboard micro-USB connection / programming port
- Invensense MPU9150 sensor chip which includes:
 1. 3 Axis Gyroscope
 2. 3 Axis Accelerometer
 3. 3 Axis Magnetometer
- MS5611 Barometer with foam cover
- Latest Venus838FLPx 50Hz GPS chipset with external antenna (SMA connector)
 1. 50Hz GPS update rate
 2. NEMA serial output for OSD (On-screen display)
- Motor port with eight speed controller outputs
- Radio port with eight radio channels inputs



1. use all four AUX inputs

- Two free serial ports (use for SBUS and/or Bluetooth or 3DR radio links)
- Three I2C ports, of which two are 3.3V and one is 5V
- 0.96" OLED port on-board
- Spektrum R/C receiver port
- Servo port with five outputs
- 2x10 I/O connector expansion port
- LIPO alarm port and LED indicator

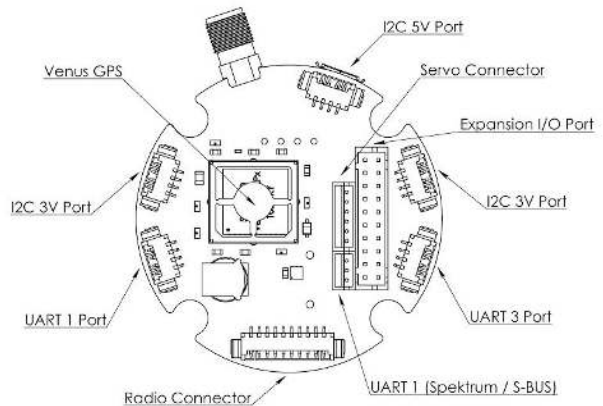
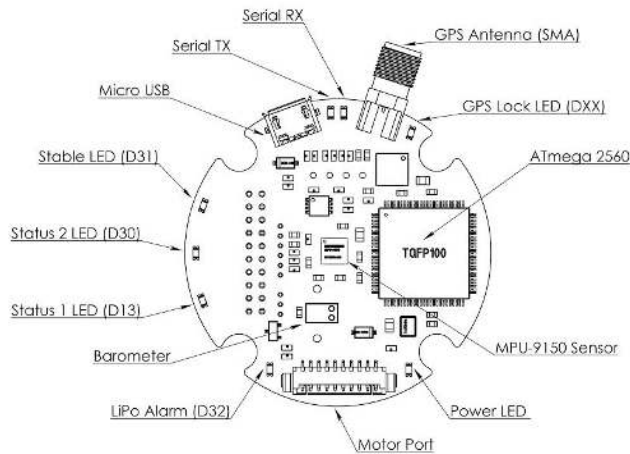

What's Included

- 1x Lynxmotion Quadrino Nano PCB (assembled)
- 1x Dark “smoked” transparent case with damping via rubber grommets for PCB
- 1x GPS Antenna SMA with 15cm cable
- 1x Radio connection wiring harness
- 1x Motor controller wiring harness
- 1x Micro USB data cable
- 4x 4-40 x 0.75" screws (for mounting the case to a frame via holes)
- 4x 4-40 Nylon Lock Nuts (for mounting the case to a frame via holes)
- 1x 3M double side adhesive Foam (for direct mounting to a frame)



Useful Links

Software

- [Quadrino Firmware Configuration Tool \(FCT\) installer](#)

Zip files

- [Pre-Configured MultiWii files \(for use without the FCT\)](#)

PDF Files

- [Lynxmotion Quadrino Nano - Quick Start v1.0](#)
- [Lynxmotion Quadrino Nano - User Guide](#)
- [Lynxmotion Quadrino Nano - Datasheet](#)

Blog

- [Lynxmotion Quadrino Nano Tutorials](#)
- [Lynxmotion Quadrino FCT – MultiWii Made Easy](#)

Dimensions

- 53 x 53mm in its casing
- 17mm height

Multimedia

<https://www.youtube.com/watch?v=j0xMEoPd520>