

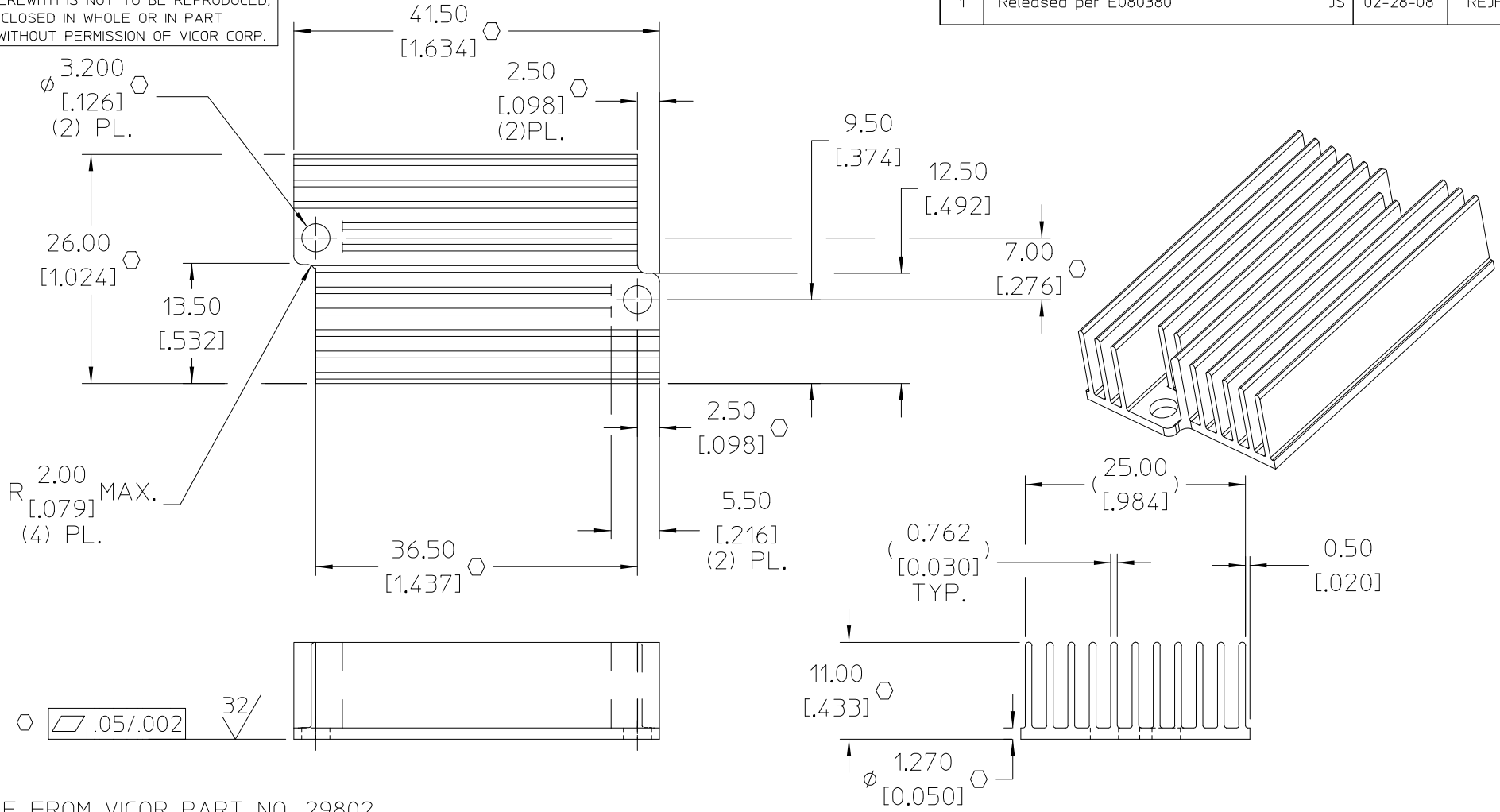

VICOR CONFIDENTIAL

THIS DOCUMENT AND THE DATA DISCLOSED HEREIN OR HEREWITH IS NOT TO BE REPRODUCED, USED, OR DISCLOSED IN WHOLE OR IN PART TO ANYONE WITHOUT PERMISSION OF VICOR CORP.

REV.	DESCRIPTION	DATE	APVD
1	Released per E080380	JS 02-28-08	REJH

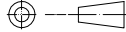

- NOTES:
1. MAKE FROM VICOR PART NO. 29802.
 2. FINISH: ELECTROLESS NICKEL PLATE PER ASTM B607-91, THICKNESS .000120" TO .000300" (3 TO 8μM)
 3. REMOVE ALL BURRS AND SHARP EDGES.
 4. "C" DENOTES CRITICAL CHARACTERISTIC FOR LOT INSPECTION.
 5. RoHS COMPLIANT, LEAD FREE PER CST-0001 LATEST REVISION.

DRAWN BY <i>R.E.J.Hickey</i>	DATE 08/09/07	 <p>HEATSINK, CONDUCTIVE 11MM LF PUSH PIN</p>		
<small>UNLESS OTHERWISE SPECIFIED DIMENSIONS ARE MM (INCH)</small> <small>TOLERANCES ARE:</small> <small>DECIMALS ANGLES</small> <small>.XX = ±0.25 [.01] ±1°</small> <small>.XXX = ±0.127 [.005]</small>				
THIRD ANGLE PROJECTION 	SIZE B	FSCM NO. 67131	DWG NO 34070	REV 1
DO NOT SCALE DRAWING		SCALE 2:1	SHEET 1 OF 1	