



A New Direction in Mixed-Signal

April 2013

SPX1431

Precision Adjustable Shunt Regulator

Rev. 2.0.1

GENERAL DESCRIPTION

The SPX1431 is a 3-terminal adjustable shunt voltage regulator providing a highly accurate bandgap reference. The SPX1431 acts as an open-loop error amplifier with a 2.5V temperature compensation reference. The SPX1431's thermal stability, wide operating current (150mA) and temperature range (-55°C to 125°C) makes it suitable for a variety of applications that require a low cost, high performance solution. SPX1431 tolerance of 0.4% is proven to be sufficient to overcome all of the other errors in the system to virtually eliminate the need for trimming in the power supply manufacturer's assembly lines and contributes a significant cost savings.

The output voltage may be adjusted to any value between VREF and 36 volts with two external resistors. The SPX1431 is available in SOIC-8 and SOT-89-3 packages.

APPLICATIONS

- **Battery Operating Equipment**
- **Adjustable Supplies**
- **Switching Power Supplies**
- **Error Amplifiers**
- **Single Supply Amplifier**
- **Monitors / VCRs / TVs**
- **Personal Computers**

FEATURES

- **Trimmed Bandgap Reference to 0.4%**
- **Wide Operating Current 1mA to 150mA**
- **-55°C to 125°C Extended Temperature Range**
- **30 ppm/°C Low Temperature Coefficient**
- **Improved Replacement in Performance for LT1431**
- **Low Cost Solution**
- **Offered in SOIC-8 and SOT-89**

TYPICAL APPLICATION DIAGRAM

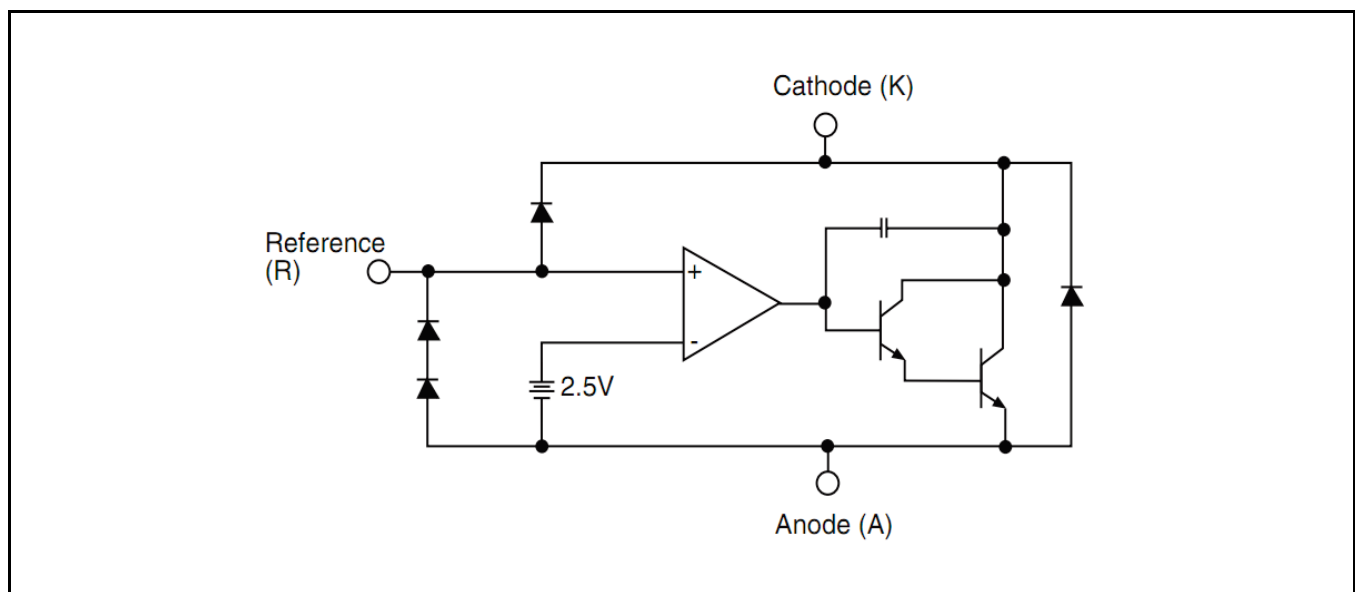

Fig. 1: SPX1431 Block Diagram

Precision Adjustable Shunt Regulator

ABSOLUTE MAXIMUM RATINGS

These are stress ratings only and functional operation of the device at these ratings or any other above those indicated in the operation sections of the specifications below is not implied. Exposure to absolute maximum rating conditions for extended periods of time may affect reliability.

- Cathode-Anode Reverse Breakdown V_{KA} 37V
- Anode-Cathode Forward Current, (<10ms) I_{AK} 1A
- Operating Cathode Current I_{KA} 150mA
- Reference Input Current I_{REF} 10mA
- Continuous Power Dissipation at 25°C P_D
- NSOIC-8 750mW
- SOT-89-3 1000mW
- Junction Temperature T_J 150°C
- Storage Temperature T_{STG} -65°C to 150°C
- ESD Rating (HBM - Human Body Model) 2kV

OPERATING RATINGS

- Cathode Voltage V_{KA} V_{REF} to 36V
- Cathode Current I_K 10mA
- Operating Junction Temperature T_J -55°C to 150°C
- Thermal Resistance
- θ_{JA} (NSOIC8) 175°C/W
- θ_{JC} (NSOIC8) 45°C/W
- θ_{JA} (SOT89-3)..... 110°C/W
- θ_{JC} (SOT89-3)..... 8°C/W

ELECTRICAL SPECIFICATIONS

Specifications with standard type are for an Operating Junction Temperature of $T_A = T_J = 25^\circ\text{C}$ only; limits applying over the full Operating Junction Temperature range are denoted by a “•”. Minimum and Maximum limits are guaranteed through test, design, or statistical correlation. Typical values represent the most likely parametric norm at $T_A = T_J = 25^\circ\text{C}$, and are provided for reference purposes only. Unless otherwise indicated, $V_K = V_{REF}$, $I_K = 10\text{mA}$, $T_A = 25^\circ\text{C}$.

Parameter	Min.	Typ.	Max.	Units	Conditions
Reference Voltage V_{REF}	2.490	2.500	2.510	V	Figure 5
	2.465		2.535		$T_J = 0^\circ\text{C}$ to 105°C , figure 5
ΔV_{REF} with Temperature TC		0.07	.20	mV/°C	Figure 5
Ratio of Change in V_{REF} to Cathode Voltage $\Delta V_{REF} / \Delta V_K$	-2.0	-1.1		mV/V	$V_K = 3\text{V}$ to 36V , figure 6
Reference Input Current I_{REF}		0.7	1.9	μA	Figure 6
I_{REF} Temp Deviation ΔI_{REF}		0.4	1.2	μA	$T_J = 0^\circ\text{C}$ to 105°C , figure 6
Min I_K for Regulation $I_{K(MIN)}$		0.4	1	mA	Figure 5
Off State Leakage $I_{K(OFF)}$		0.04	250	nA	$V_{REF} = 0\text{V}$, $V_{KA} = 36\text{V}$, figure 7
Dynamic Output Impedance Z_{KA}		0.15	0.5	Ω	$f_z \leq 1\text{kHz}$, $I_K = 1$ to 150mA , figure 5

BLOCK DIAGRAM

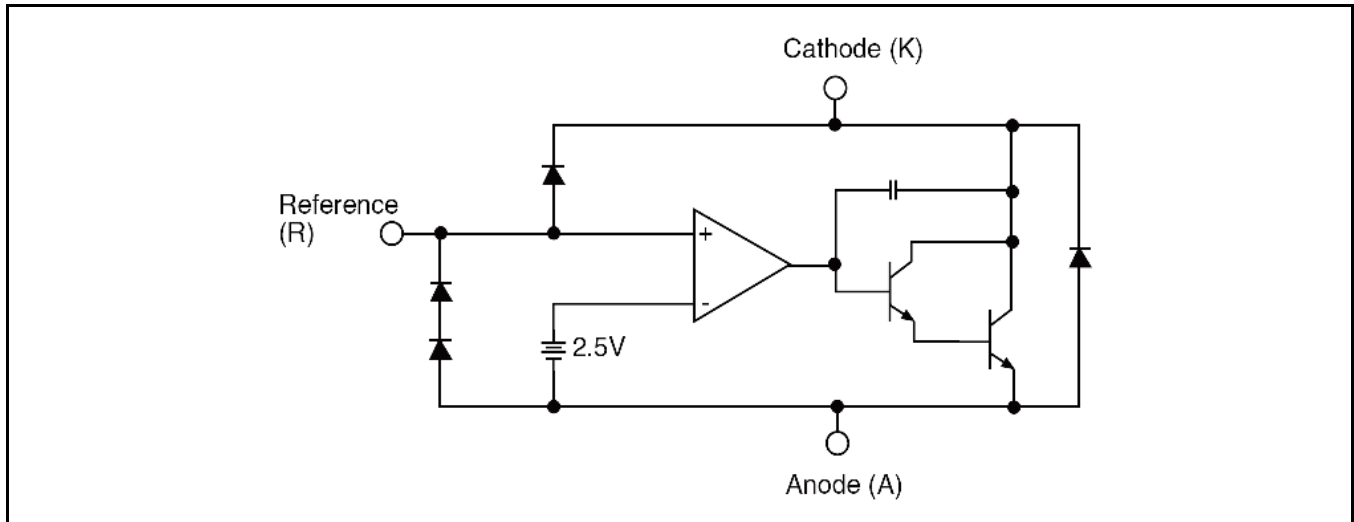

Fig. 2: SPX1431 Block Diagram

PIN ASSIGNMENT

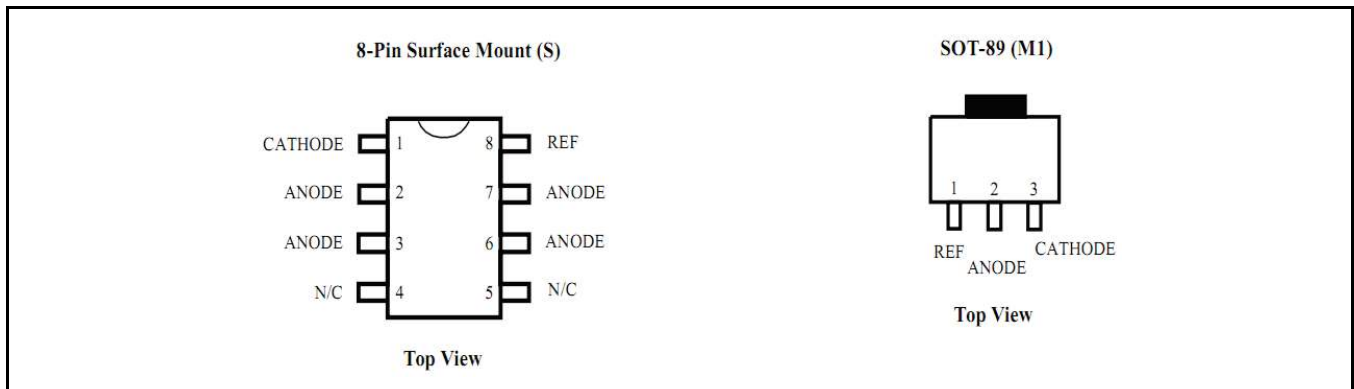

Fig. 3: SPX1431 Pin Assignment

ORDERING INFORMATION

Part Number	Temperature Range	Marking	Package	Packing Quantity	Note 1	Note 2
SPX1431M1-L	-55°C ≤ T _J ≤ +125°C	N011 YWWXXX	SOT-89-3	Bulk	Halogen Free	Bar on left side of marking denotes "-L" Pb free product
SPX1431M1-L/TR				2.5K/Tape & Reel		
SPX1431S-L	-55°C ≤ T _J ≤ +125°C	SPX1431 25YYWWL XXXXXXX	NSOIC8	Bulk	Halogen Free	
SPX1431S-L/TR				2.5K/Tape & Reel		

"YY" = Year (Last two digits) – "Y" = Year (Last Digit)

"WW" = Work Week

"XXX" = Lot Number (Example AA234567)

"XXXXXX" = Lot Number (Example AA234567)

These products have no bottom side marking.

CALCULATING AVERAGE TEMPERATURE COEFFICIENT (TC)

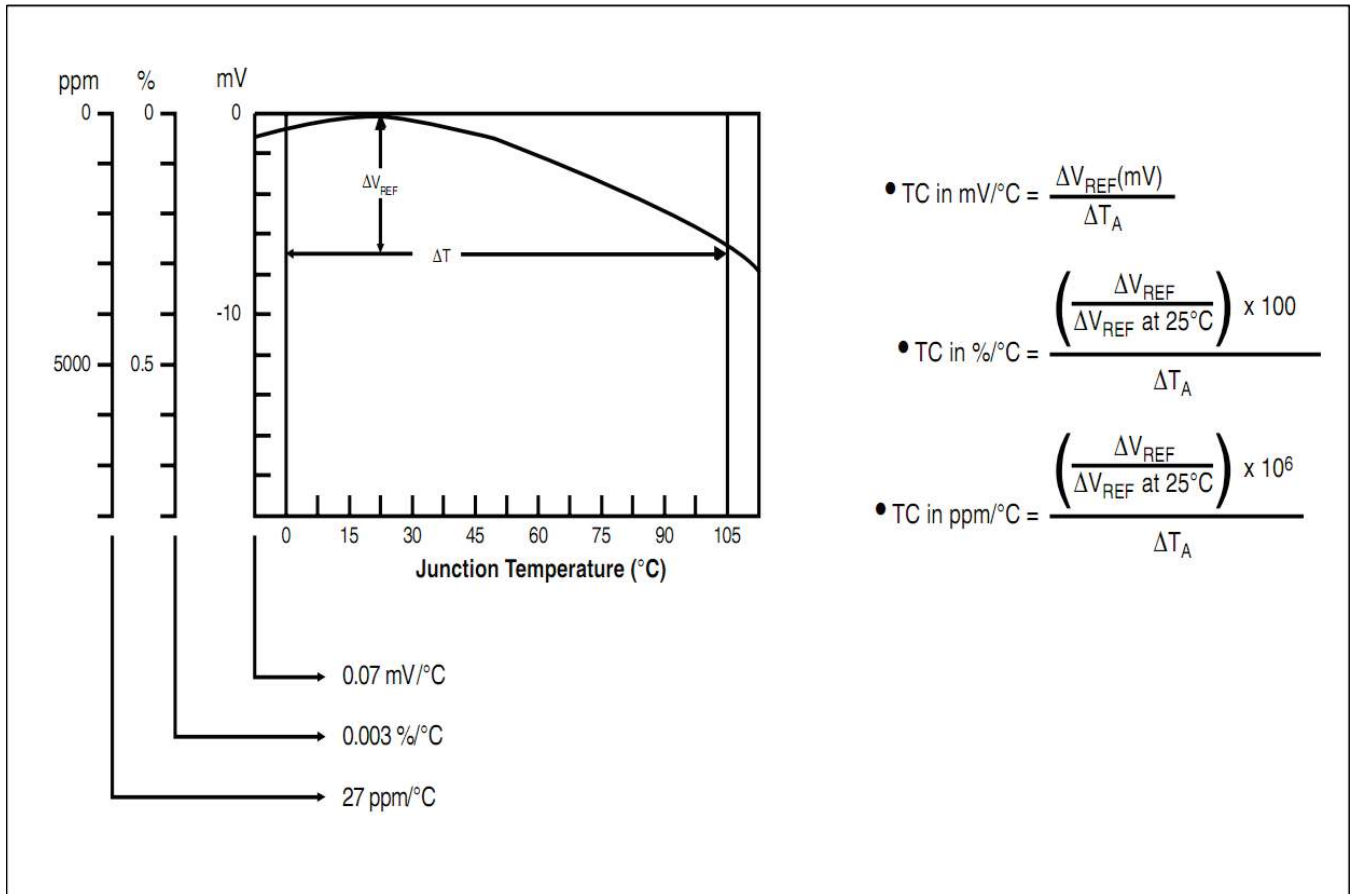

Fig. 4: V_{REF} vs. Temperature

TEST CIRCUITS

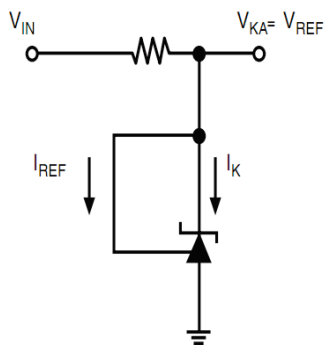

Fig. 5: Test Circuit for $V_{KA} = V_{REF}$

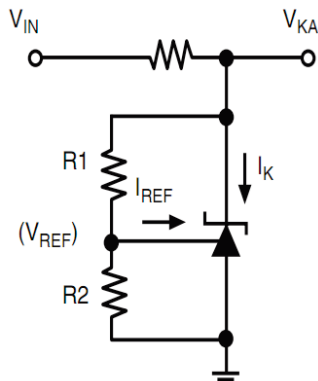

Fig. 6: Test Circuit for $V_{KA} > V_{REF}$

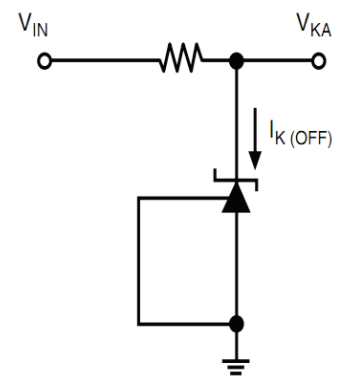

Fig. 7: Test Circuit for $I_{K(OFF)}$



A New Direction in Mixed-Signal

Precision Adjustable Shunt Regulator

TYPICAL PERFORMANCE CHARACTERISTICS

All data taken at Unless otherwise indicated, $V_K = V_{REF}$, $I_K = 10\text{mA}$, $T_A = 25^\circ\text{C}$.

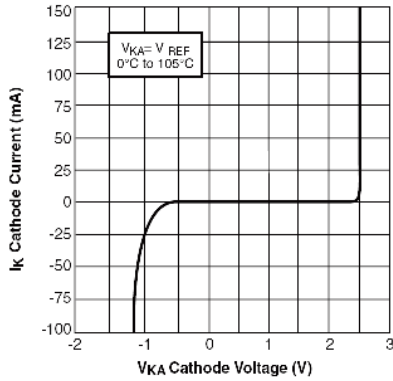

Fig. 8: High Current Operating Characteristics

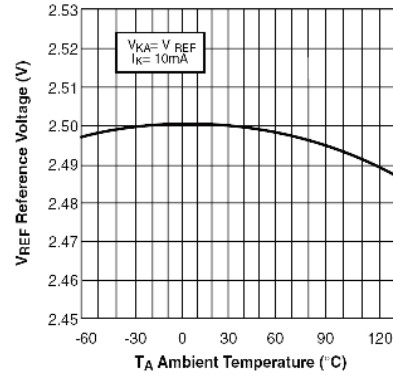

Fig. 9: Reference Voltage vs. Ambient Temperature

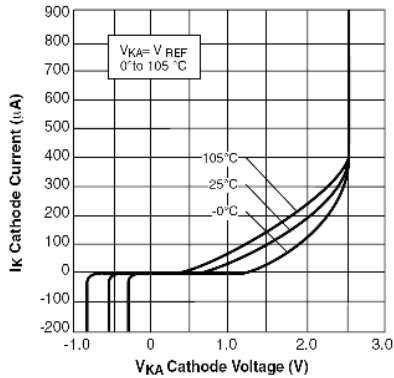

Fig. 10: Low Current Operating Characteristics

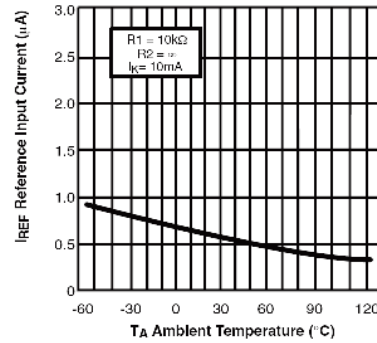

Fig. 11: Reference Input Current vs. Ambient Temperature

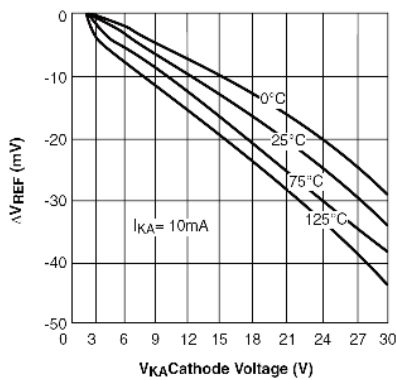

Fig. 12: Reference Voltage Line Regulation vs. Cathode Voltage and $T_{AMBIENT}$

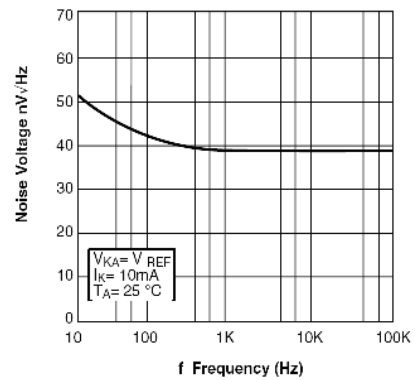

Fig. 13: Noise Voltage vs. Frequency

Precision Adjustable Shunt Regulator

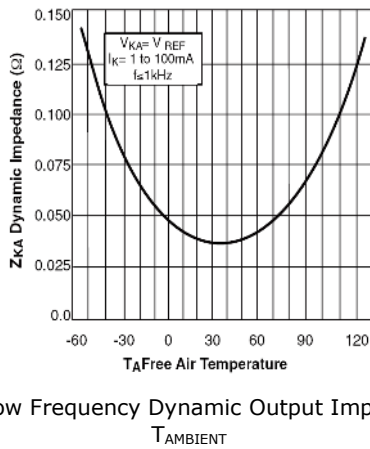

Fig. 14: Low Frequency Dynamic Output Impedance vs. $T_{AMBIENT}$

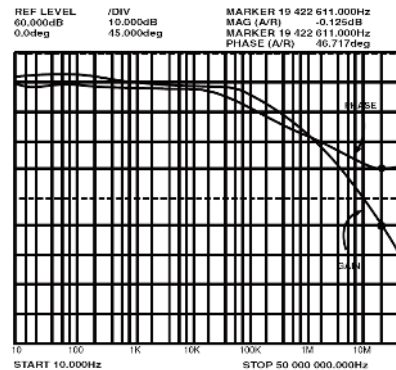

Fig. 15: Small Signal Gain and Phase vs. Frequency; $I_K = 10mA, T_A = 25^\circ C$

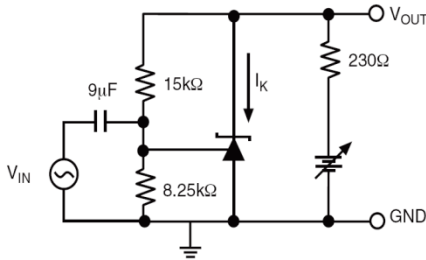

Fig. 16: Test Circuit for Gain and Phase Frequency Response

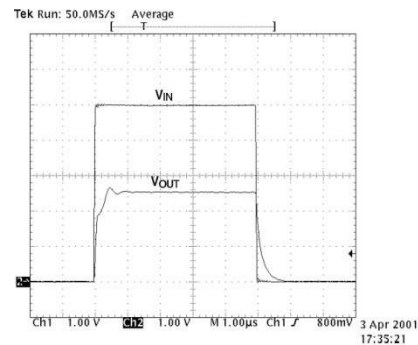

Fig. 17: Frequency = 100kHz $I_K = 10mA, T_A = 25^\circ C$

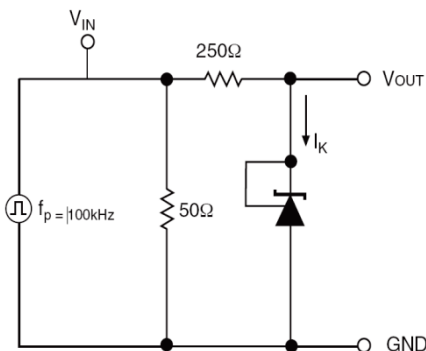

Fig. 18: Test Circuit for Pulse Response

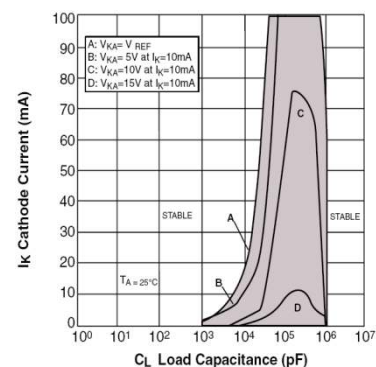

Fig. 19: Stability Boundary Conditions

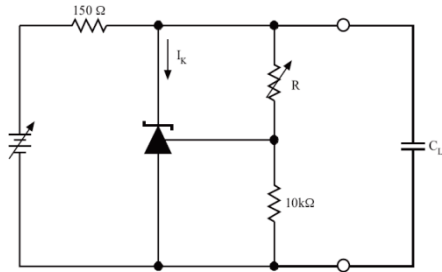

Fig. 20: Test Circuit for Stability

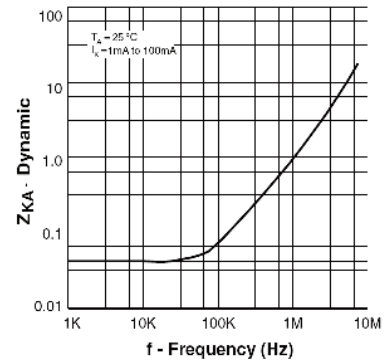

Fig. 21: Dynamic Output Impedance
 $T_A = 25^\circ\text{C}$, $I_K = 1$ to 100mA

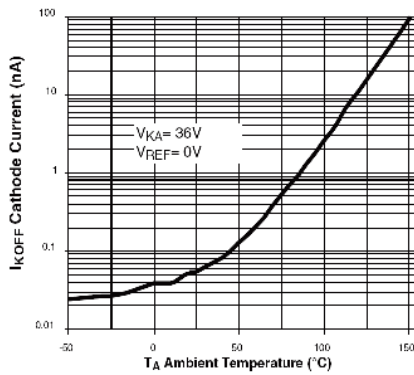

Fig. 22: Off State Leakage

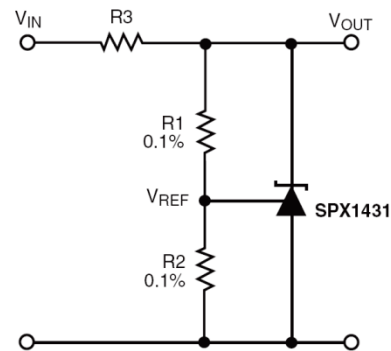

Fig. 23: Shunt Regulator $V_{OUT} = (1+R1/R2) \cdot V_{REF}$

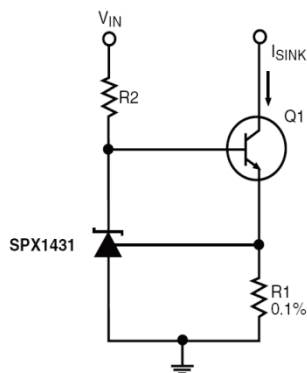

Fig. 24: Constant Current, Sink, $I_{SINK} = V_{REF}/R1$

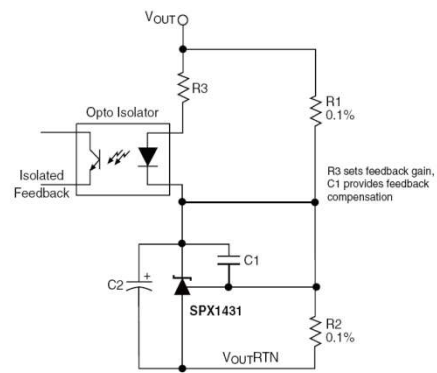

Fig. 25: Reference Amplifier for Isolated Feedback in Off-Line DC-DC Converters

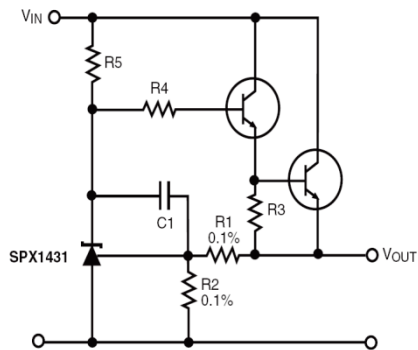

Fig. 26: Precision High Current Series Regulator

$$V_{OUT} = (1 + R1/R2)V_{REF}$$

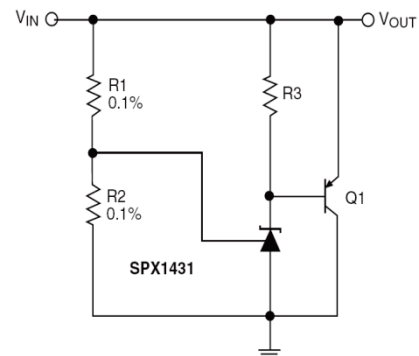

Fig. 27: High Current Shunt Regulator

$$V_{OUT} = (1 + R1/R2)V_{REF}$$

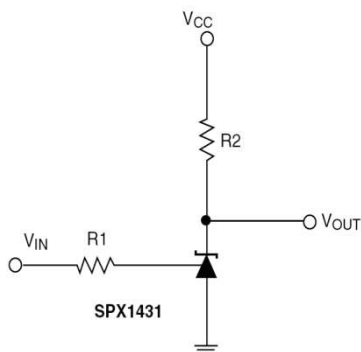

Fig. 28: Single Supply Comparator with Temperature Compensated Threshold. V_{IN} threshold = 2.5V

Resistor values are chosen such that the effect to I_{REF} is negligible.



A New Direction in Mixed-Signal

SPX1431

Precision Adjustable Shunt Regulator

PACKAGE SPECIFICATION

SOT-89-3

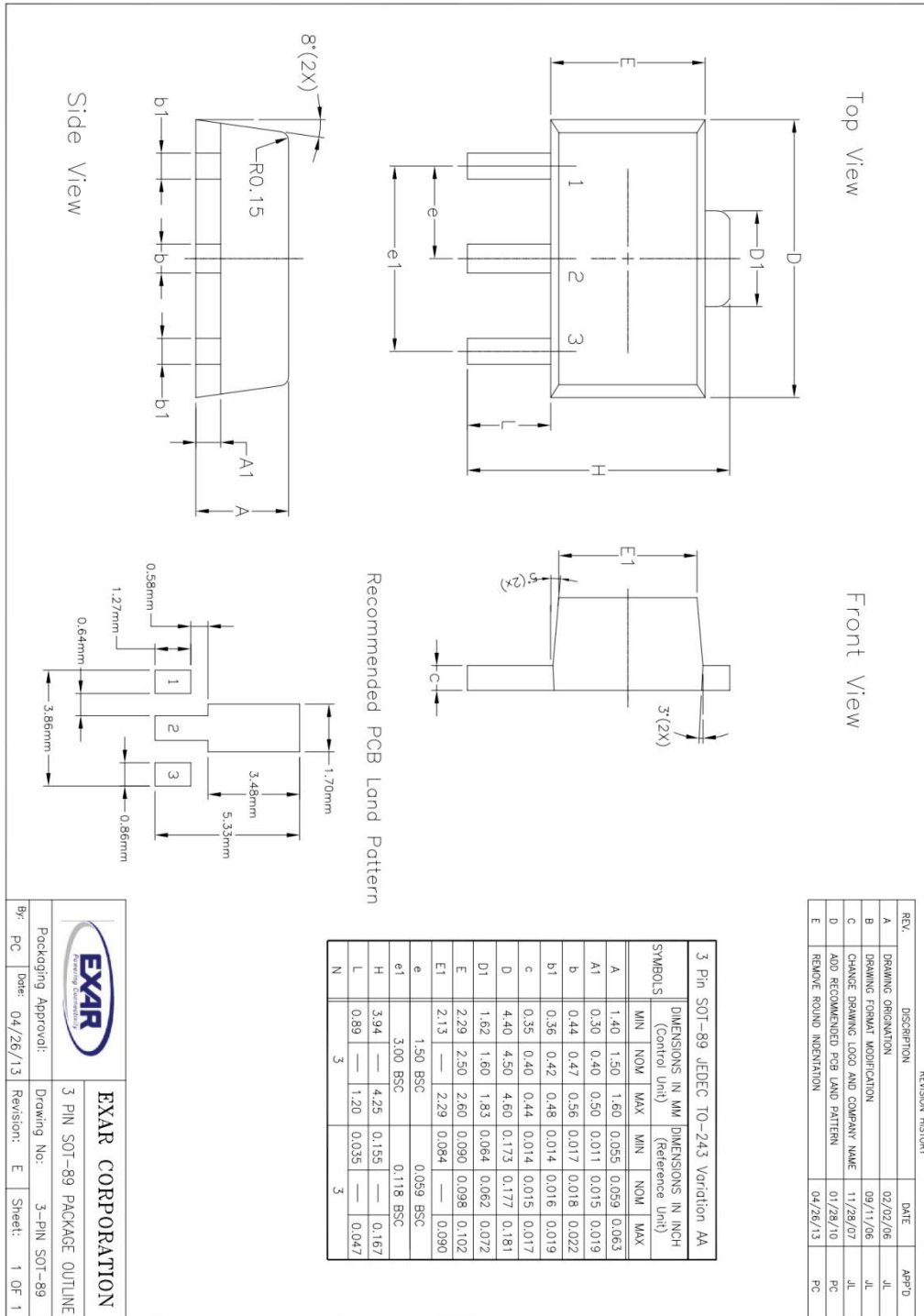

REVISION HISTORY			
REV.	DESCRIPTION	DATE	APP'D
A	DRAWING ORIGINATOR	02/02/06	JL
B	DRAWING FORMAT MODIFICATION	09/11/06	JL
C	CHANGE DRAWING LOGO AND COMPANY NAME	11/28/07	JL
D	ADD RECOMMENDED PCB LAND PATTERN	01/28/10	PC
E	REMOVE ROUND INDENTATION	04/26/13	PC

		EXAR CORPORATION	
Packaging Approval:		Drawing No:	
By: PC		3 PIN SOT-89 PACKAGE OUTLINE	
Date: 04/26/13		3-PIN SOT-89	
Revision: E		Sheet: 1 OF 1	



A New Direction in Mixed-Signal

SPX1431

Precision Adjustable Shunt Regulator

NSOIC-8

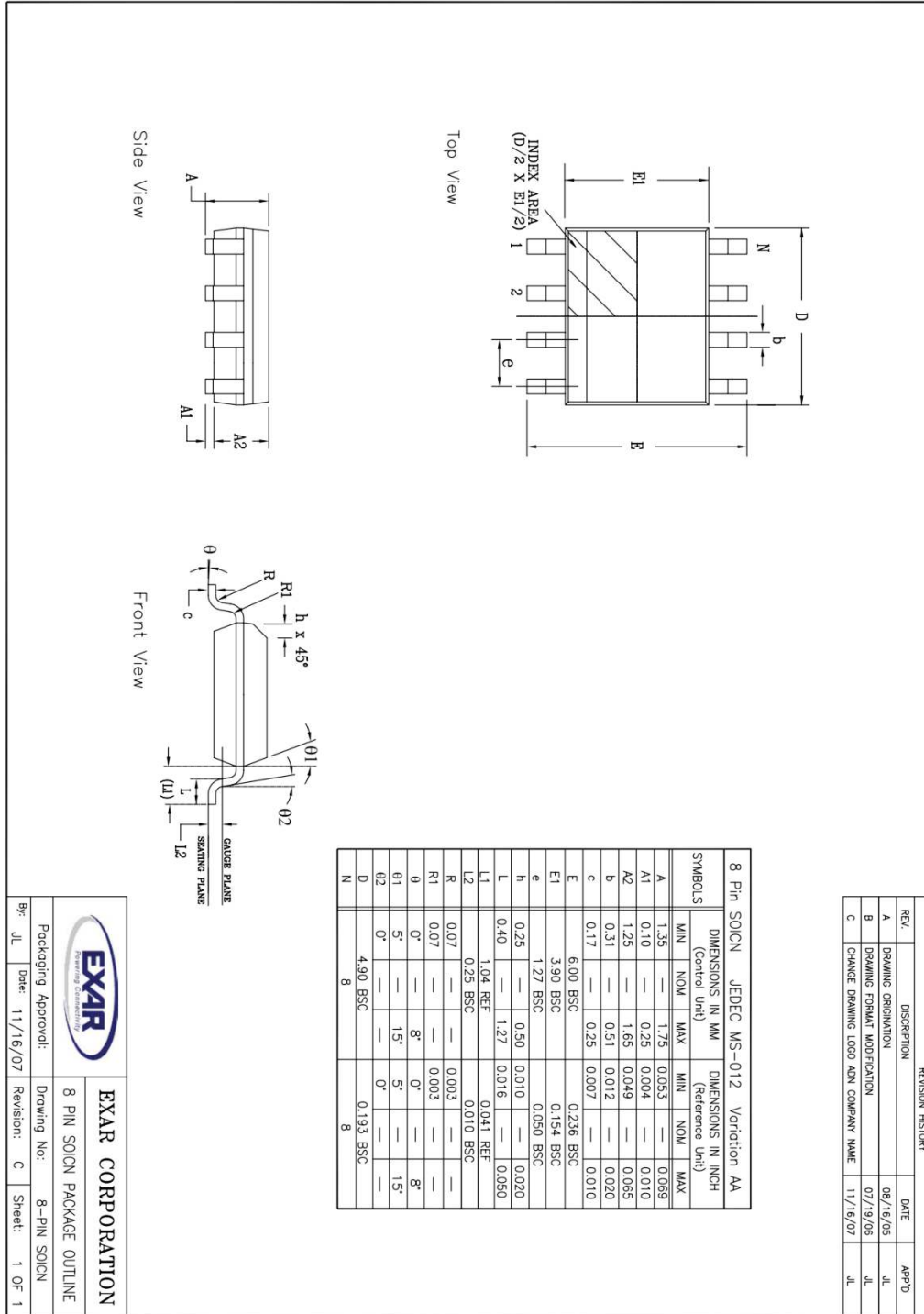

REVISION HISTORY			
REV.	DESCRIPTION	DATE	APP'D
A	DRAWING ORIGINATOR	08/16/05	JL
B	DRAWING FORMAT MODIFICATION	07/19/06	JL
C	CHANGE DRAWING LOGO AND COMPANY NAME	11/16/07	JL

		EXAR CORPORATION <small>PRECISION SIGNALS</small>	
By: JL	Date: 11/16/07	Drawing No: 8-PIN SOICN	Sheet: 1 OF 1
Packaging Approval:		Revision: C	Sheet: 1 OF 1

REVISION HISTORY

Revision	Date	Description
2.0.0	04/26/2013	Reformat of Datasheet Update of SOT89-3 package specification Added ESD rating in Absolute Maximum Ratings
2.0.1	07/19/2013	Updated Top Mark information and provided clarifying information

FOR FURTHER ASSISTANCE

Email:

customersupport@exar.com

powertechsupport@exar.com

Exar Technical Documentation:

[http://www.exar.com/TechDoc/default.aspx?](http://www.exar.com/TechDoc/default.aspx)



EXAR CORPORATION

HEADQUARTERS AND SALES OFFICES

48720 Kato Road

Fremont, CA 94538 – USA

Tel.: +1 (510) 668-7000

Fax: +1 (510) 668-7030

www.exar.com

NOTICE

EXAR Corporation reserves the right to make changes to the products contained in this publication in order to improve design, performance or reliability. EXAR Corporation assumes no responsibility for the use of any circuits described herein, conveys no license under any patent or other right, and makes no representation that the circuits are free of patent infringement. Charts and schedules contained here in are only for illustration purposes and may vary depending upon a user's specific application. While the information in this publication has been carefully checked; no responsibility, however, is assumed for inaccuracies.

EXAR Corporation does not recommend the use of any of its products in life support applications where the failure or malfunction of the product can reasonably be expected to cause failure of the life support system or to significantly affect its safety or effectiveness. Products are not authorized for use in such applications unless EXAR Corporation receives, in writing, assurances to its satisfaction that: (a) the risk of injury or damage has been minimized; (b) the user assumes all such risks; (c) potential liability of EXAR Corporation is adequately protected under the circumstances.

Reproduction, in part or whole, without the prior written consent of EXAR Corporation is prohibited.