

MODEL CUB4L & CUB4L8 - MINIATURE ELECTRONIC COUNTERS



- LCD, POSITIVE REFLECTIVE OR NEGATIVE TRANSMISSIVE WITH YELLOW/GREEN OR RED LED BACKLIGHTING
- INTERNAL LITHIUM BATTERY PROVIDES UP TO 6 YEARS OF UNINTERRUPTED OPERATION
- NEMA 4X/IP65 SEALED FRONT BEZEL
- FRONT PANEL RESET, REMOTE RESET, OR BOTH
- COUNT SPEEDS UP TO 5 KHZ
- WIRE CONNECTION MADE VIA SCREW CLAMP TYPE TERMINALS

DESCRIPTION

The CUB4 offers a large display in a miniature package with a choice of three displays; reflective, red backlight or green backlight.

The backlight versions require power from an external 9–28 VDC supply. The optional power supply (MLPS) is designed to be attached directly to the rear of the CUB4 and is powered from an 85–250 VAC source.

The CUB4 series has a lightweight, high impact plastic case with a clear viewing window. The sealed front panel with the silicone rubber reset button meets NEMA 4X/IP65 specifications for wash-down and/or dusty environments, when properly installed.

ORDERING INFORMATION

MODEL NO.	DESCRIPTION	PART NUMBERS
CUB4L (6-digit)	Counter Positive Image Reflective	CUB4L000
	Counter w/Yel-Grn Backlighting	CUB4L010
	Counter w/Red Backlighting	CUB4L020
CUB4L8 (8-digit)	Counter Positive Image Reflective	CUB4L800
	Counter w/Yel-Grn Backlighting	CUB4L810
	Counter w/Red Backlighting	CUB4L820
MLPS	+12 VDC Micro-Line Power Supply, 85 to 250 VAC source, 400 mA max out	MLPS1000
	+24 VDC Micro-Line Power Supply, 85 to 250 VAC source, 200 mA max out	MLPS2000

SAFETY SUMMARY

All safety related regulations, local codes as well as instructions that appear in this document or on equipment must be observed to ensure personal safety and to prevent damage to either the device or equipment connected to it.

Do not use these products to replace proper safety interlocking. No software-based device (or any other solid-state device) should ever be designed to be responsible for the maintenance of personnel safety or consequential equipment not equipped with safeguards. Red Lion disclaims any responsibility for damages, either direct or consequential, that result from the use of this equipment in a manner not consistent with these specifications.

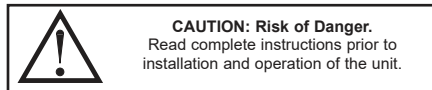

SPECIFICATIONS

- DISPLAY:**
 CUB4L: 6-Digit, LCD, 0.48" (12.2 mm) high digits.
 CUB4L8: 8-Digit, LCD, 0.46" (11.7 mm) high digits.
- POWER SOURCE:** Internal 3.6 V lithium battery will provide up to 6 years of continuous operation (high speed counting and extreme temperatures will decrease battery life).
- BACKLIGHT POWER REQUIREMENTS:** 9 to 28 VDC, 30 mA typical, 50 mA max. Above 26 VDC, derate operating temperature to 50°C. Must use an RLC model MLPS or an NEC Class 2 or Limited Power Source (LPS) rated power supply.
- COUNT INPUT:**
 SNK mode (DIP switch 1 off, internal pull-up to battery)
 V_{IN} High Min = 1.25 VDC; V_{IN} Low Max = 0.45 VDC
 I_{IN} Max = 5 μ A; V_{IN} Max = 3.6 VDC
 Count Speed: (count on negative edge)
 High freq mode (DIP switch 2 off): max 5 kHz @ 50% duty cycle
 Low freq mode (DIP switch 2 on): max 50 Hz @ 50% duty cycle
 SRC mode (DIP switch 1 on, internal 20 k Ω pull-down to common)
 V_{IN} High Min = 1.25 VDC; V_{IN} Low Max = 0.45 VDC
 I_{IN} Max = 5 mA; V_{IN} Max = 28 VDC
 Count Speed: (count on negative edge)
 High freq mode (DIP switch 2 off): max 5 kHz @ 50% duty cycle
 Low freq mode (DIP switch 2 on): max 50 Hz @ 50% duty cycle
- RESET INPUT:**
 V_{IN} Low Max = 1.5 VDC (internal pull-up to battery)
 I_{IN} Max = 20 μ A
 5 msec min (active low for count reset to zero)
- ENVIRONMENTAL CONDITIONS:**
Operating Temperature: 0 to 60°C (above 50°C, derate backlight operating voltage to 26 VDC max.).
Storage Temperature: -30 to 85°C
Operating and Storage Humidity: 85% max. (non-condensing) from 0°C to 50°C.
Vibration to IEC 68-2-6: 5 to 500 Hz, 5 g.
Shock to IEC 68-2-27: Operational 30 g.
Altitude: Up to 2000 meters

DIMENSIONS In inches [mm]

Note: Recommended minimum clearance (behind the panel) for mounting clip installation is 2.15" (54.6) H x 3.00" (76.2) W.

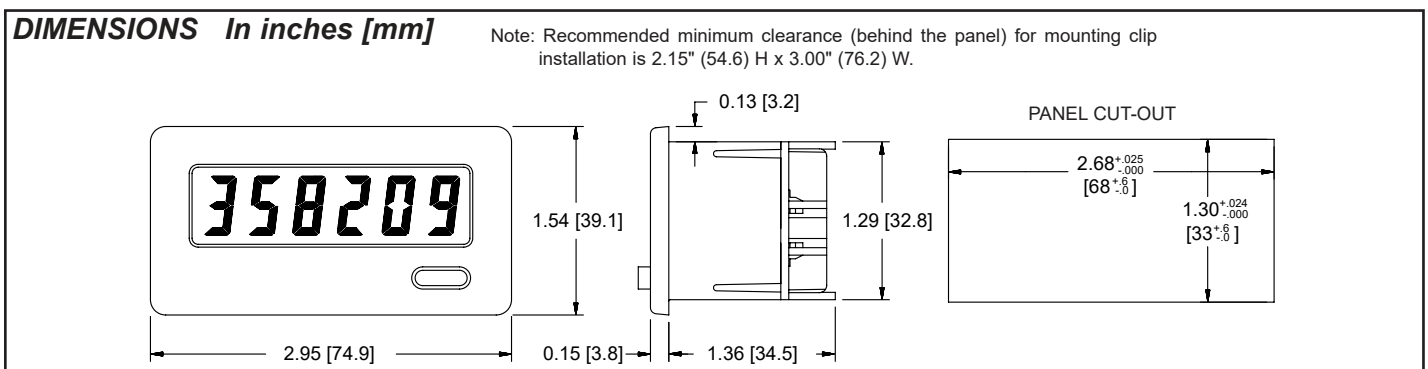

7. CERTIFICATIONS AND COMPLIANCES:

CE Approved

EN 61326-1 Immunity to Industrial Locations

Emission CISPR 11 Class B

IEC/EN 61010-1

RoHS Compliant

UL Recognized Component: File #E179259

Type 4X Indoor Enclosure rating (Face only)

IP65 Enclosure rating (Face only)

Refer to EMC Installation Guidelines section of the bulletin for additional information.

8. CONSTRUCTION:

This unit is rated for NEMA 4X/IP65 indoor use. Installation Category I, Pollution Degree 2

9. WEIGHT: 3 oz. (85 grams)

EMC INSTALLATION GUIDELINES

Although Red Lion Controls products are designed with a high degree of immunity to Electromagnetic Interference (EMI), proper installation and wiring methods must be followed to ensure compatibility in each application. The type of the electrical noise, source or coupling method into a unit may be different for various installations. Cable length, routing, and shield termination are very important and can mean the difference between a successful or troublesome installation. Listed are some EMI guidelines for a successful installation in an industrial environment.

1. A unit should be mounted in a metal enclosure, which is properly connected to protective earth.
2. Use shielded cables for all Signal and Control inputs. The shield connection should be made as short as possible. The connection point for the shield depends somewhat upon the application. Listed below are the recommended methods of connecting the shield, in order of their effectiveness.
 - a. Connect the shield to earth ground (protective earth) at one end where the unit is mounted.
 - b. Connect the shield to earth ground at both ends of the cable, usually when the noise source frequency is over 1 MHz.
3. Never run Signal or Control cables in the same conduit or raceway with AC power lines, conductors, feeding motors, solenoids, SCR controls, and heaters, etc. The cables should be run through metal conduit that is properly

grounded. This is especially useful in applications where cable runs are long and portable two-way radios are used in close proximity or if the installation is near a commercial radio transmitter. Also, Signal or Control cables within an enclosure should be routed as far away as possible from contactors, control relays, transformers, and other noisy components.

4. Long cable runs are more susceptible to EMI pickup than short cable runs.
5. In extremely high EMI environments, the use of external EMI suppression devices such as Ferrite Suppression Cores for signal and control cables is effective. The following EMI suppression devices (or equivalent) are recommended:

Fair-Rite part number 0443167251 (Red Lion #FCOR0000)

Line Filters for input power cables:

Schaffner # FN2010-1/07 (Red Lion #LFIL0000)

6. To protect relay contacts that control inductive loads and to minimize radiated and conducted noise (EMI), some type of contact protection network is normally installed across the load, the contacts or both. The most effective location is across the load.

- a. Using a snubber, which is a resistor-capacitor (RC) network or metal oxide varistor (MOV) across an AC inductive load is very effective at reducing EMI and increasing relay contact life.
- b. If a DC inductive load (such as a DC relay coil) is controlled by a transistor switch, care must be taken not to exceed the breakdown voltage of the transistor when the load is switched. One of the most effective ways is to place a diode across the inductive load. Most Red Lion products with solid state outputs have internal zener diode protection. However external diode protection at the load is always a good design practice to limit EMI. Although the use of a snubber or varistor could be used.

Red Lion part numbers: Snubber: SNUB0000

Varistor: ILS11500 or ILS23000

7. Care should be taken when connecting input and output devices to the instrument. When a separate input and output common is provided, they should not be mixed. Therefore a sensor common should NOT be connected to an output common. This would cause EMI on the sensitive input common, which could affect the instrument's operation.

Visit <http://www.redlion.net/emi> for more information on EMI guidelines, Safety and CE issues as they relate to Red Lion products.

INSTALLATION ENVIRONMENT

The unit should be installed in a location that does not exceed the maximum operating temperature and provides good air circulation. Placing the unit near devices that generate excessive heat should be avoided.

The bezel should be cleaned only with a soft cloth and neutral soap product. Do NOT use solvents. Continuous exposure to direct sunlight may accelerate the aging process of the bezel.

Do not use tools of any kind (screwdrivers, pens, pencils, etc.) to operate the keypad of the unit.

Installation

The CUB4 series of products meet NEMA 4X/IP65 requirements for indoor use, when properly installed. The units are intended to be mounted into an enclosed panel. The viewing window and reset button are factory sealed for a washdown environment. A sponge rubber gasket and mounting clip are provided for sealing the unit in the panel cut-out.

The following procedure assures proper installation:

1. Cut panel opening to specified dimensions. Remove burrs and clean around panel opening.
2. Carefully remove the center section of the panel gasket and discard. Slide gasket over rear of the unit to the back of the bezel.
3. Assemble nut fastener first and then mounting screw onto both sides of mounting clip. Tip of screw should not project from hole in mounting clip.
4. Install CUB4 unit through the panel cut-out until front bezel flange contacts the panel-mounted gasket.
5. Slide the mounting clip over the rear of the unit until the mounting clip is against the back of the panel. The mounting clip has latching features which engage into mating features on the CUB4 housing.

Note: It is necessary to hold the unit in place when sliding mounting clip into position.

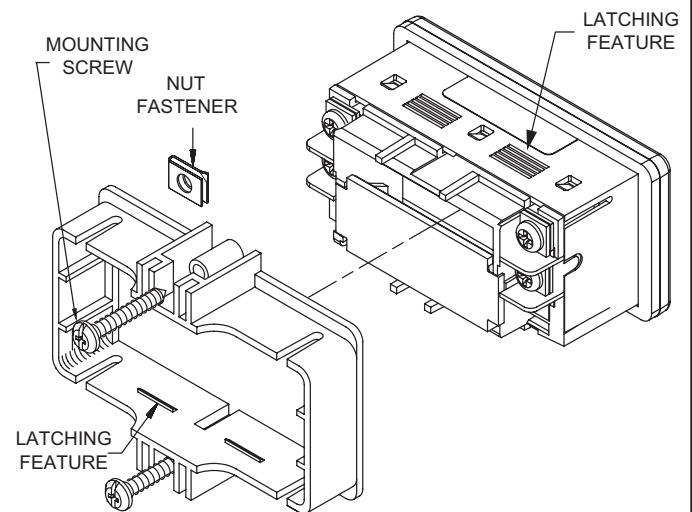

6. Alternately tighten each screw to ensure uniform gasket pressure. Visually inspect the front panel gasket. The gasket should be compressed about 75 to 80% of its original thickness. (Recommended torque is 28 to 36 in-oz.) If not, gradually turn mounting screws to further compress gasket.
7. If gasket is not adequately compressed, and mounting screws can no longer be turned, loosen mounting screws and check that mounting clip is latched as close as possible to panel. Repeat procedure for tightening mounting screws.

WIRING CONNECTIONS

The electrical connections are made via rear screw-clamp terminals located on the back of the unit. When wiring the unit, use the label to identify the wire position with the proper function. All conductors should meet voltage and current ratings for each terminal. Also cabling should conform to appropriate standards of good installation, local codes and regulations. It is recommended that power supplied to the unit (AC or DC) be protected by a fuse or circuit breaker. Strip the wire, leaving approximately 1/4" bare wire exposed (*stranded wires should be tinned with solder*). Insert the wire into the screw-clamp terminal and tighten down the screw until the wire is clamped tightly. Each terminal can accept up to two #14 AWG wires.

Backlight Wiring

Optional backlight versions of the CUB4 require an external 9-28 VDC power supply. The external supply is connected between the V+ and Common terminals.

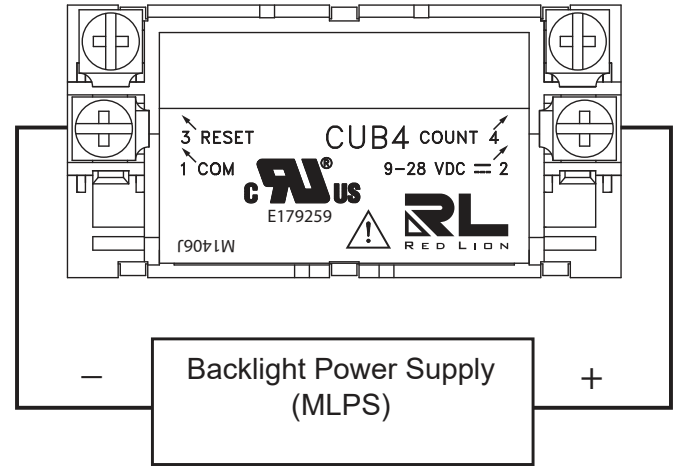

Warning: Lithium battery may explode if incinerated.

COUNT INPUT WIRING

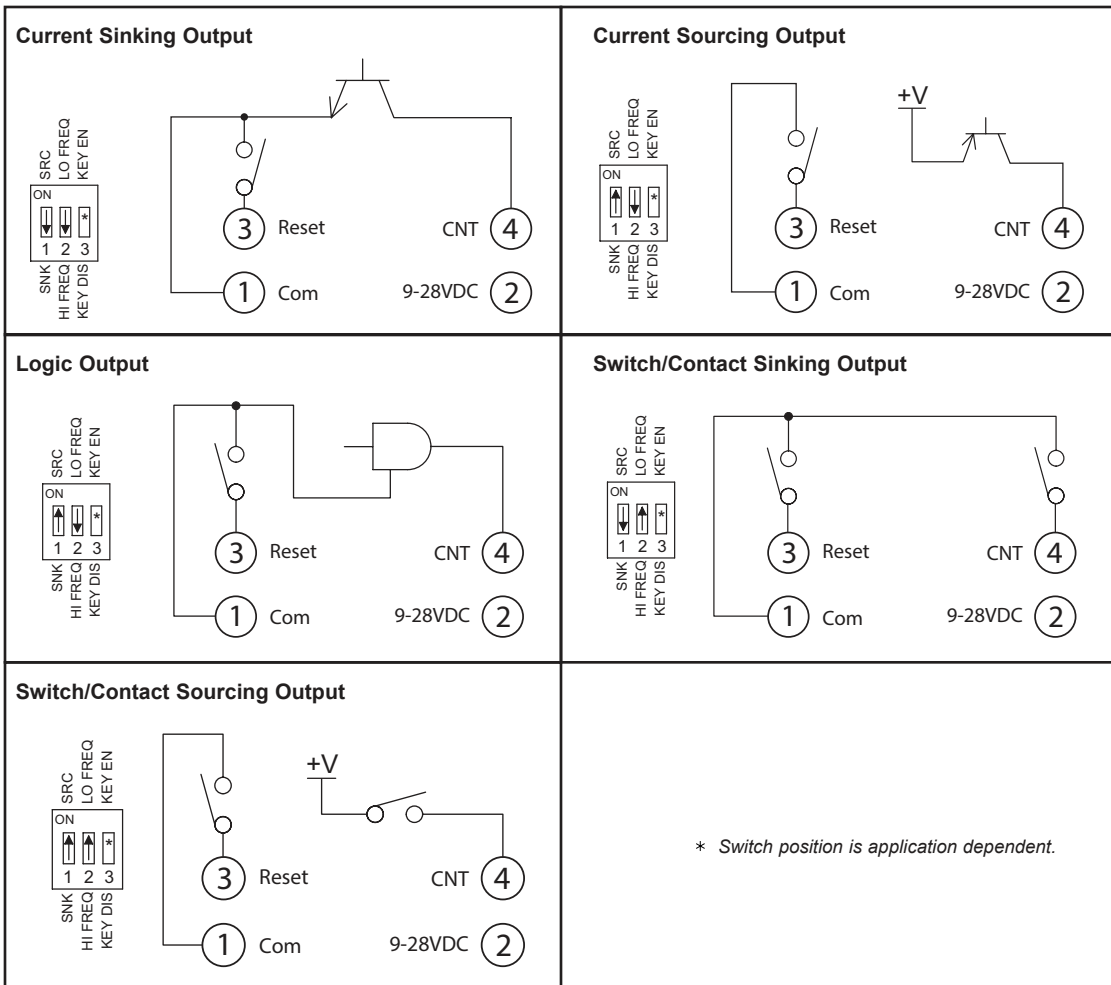

SETTING THE DIP SWITCHES

The switches must be positioned appropriately prior to wiring. Placing the key disable/enable DIP switch in the off position disables the front panel key.

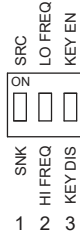
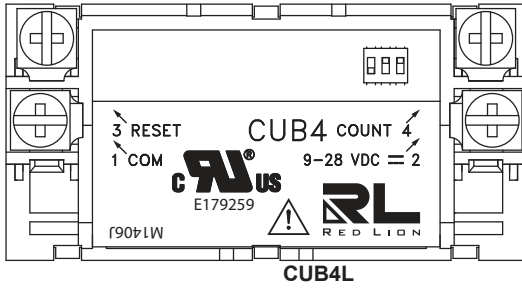

RED LION CONTROLS TECHNICAL SUPPORT

If for any reason you have trouble operating, connecting, or simply have questions concerning your new product, contact Red Lion's technical support.

Support: support.redlion.net

Website: www.redlion.net

Inside US: +1 (877) 432-9908

Outside US: +1 (717) 767-6511

Red Lion Controls, Inc.

35 Willow Springs Circle York, PA 17406

COPYRIGHT

©2022 Red Lion Controls, Inc. All rights reserved. Red Lion and the Red Lion logo are trademarks of Red Lion Controls, Inc. All other company and product names are trademarks of their respective owners.

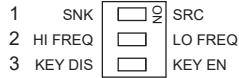
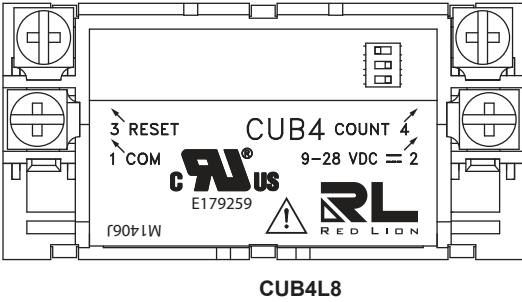

RESETTING THE DISPLAY

The display may be reset to zero via the front RST key, the remote reset input or both. The front RST key must be enabled for front panel reset by setting DIP switch # 3 ON. The remote reset is activated via an external momentary contact closure between the reset input and the common.

LIMITED WARRANTY

(a) Red Lion Controls Inc. (the "Company") warrants that all Products shall be free from defects in material and workmanship under normal use for the period of time provided in "Statement of Warranty Periods" (available at www.redlion.net) current at the time of shipment of the Products (the "Warranty Period"). **EXCEPT FOR THE ABOVE-STATED WARRANTY, COMPANY MAKES NO WARRANTY WHATSOEVER WITH RESPECT TO THE PRODUCTS, INCLUDING ANY (A) WARRANTY OF MERCHANTABILITY; (B) WARRANTY OF FITNESS FOR A PARTICULAR PURPOSE; OR (C) WARRANTY AGAINST INFRINGEMENT OF INTELLECTUAL PROPERTY RIGHTS OF A THIRD PARTY; WHETHER EXPRESS OR IMPLIED BY LAW, COURSE OF DEALING, COURSE OF PERFORMANCE, USAGE OF TRADE OR OTHERWISE.** Customer shall be responsible for determining that a Product is suitable for Customer's use and that such use complies with any applicable local, state or federal law.

(b) The Company shall not be liable for a breach of the warranty set forth in paragraph (a) if (i) the defect is a result of Customer's failure to store, install, commission or maintain the Product according to specifications; (ii) Customer alters or repairs such Product without the prior written consent of Company.

(c) Subject to paragraph (b), with respect to any such Product during the Warranty Period, Company shall, in its sole discretion, either (i) repair or replace the Product; or (ii) credit or refund the price of Product provided that, if Company so requests, Customer shall, at Company's expense, return such Product to Company.

(d) **THE REMEDIES SET FORTH IN PARAGRAPH (c) SHALL BE THE CUSTOMER'S SOLE AND EXCLUSIVE REMEDY AND COMPANY'S ENTIRE LIABILITY FOR ANY BREACH OF THE LIMITED WARRANTY SET FORTH IN PARAGRAPH (a).**

BY INSTALLING THIS PRODUCT, YOU AGREE TO THE TERMS OF THIS WARRANTY, AS WELL AS ALL OTHER DISCLAIMERS AND WARRANTIES IN THIS DOCUMENT.