

Silicon Power Schottky Diode

$V_{RRM} = 45\text{ V} - 100\text{ V}$

$I_{F(AV)} = 300\text{ A}$

Features

- High Surge Capability
- Types from 45 V to 100 V V_{RRM}
- Isolation Type Package
- Electrically Isolated Base Plate
- Not ESD Sensitive

Three Tower Package

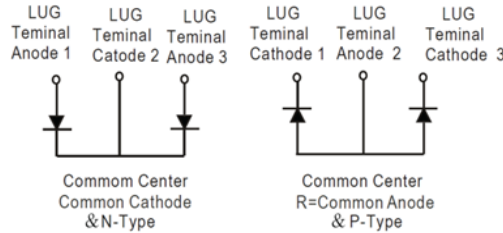

Maximum ratings, at $T_j = 25\text{ }^\circ\text{C}$, unless otherwise specified ("R" devices have leads reversed)

Parameter	Symbol	Conditions	MBRT30045(R)	MBRT30060(R)	MBRT30080(R)	MBRT300100(R)	Unit
Repetitive peak reverse voltage	V_{RRM}		45	60	80	100	V
RMS reverse voltage	V_{RMS}		32	42	56	70	V
DC blocking voltage	V_{DC}		45	60	80	100	V
Operating temperature	T_j		-55 to 150	-55 to 150	-55 to 150	-55 to 150	$^\circ\text{C}$
Storage temperature	T_{stg}		-55 to 150	-55 to 150	-55 to 150	-55 to 150	$^\circ\text{C}$

Electrical characteristics, at $T_j = 25\text{ }^\circ\text{C}$, unless otherwise specified

Parameter	Symbol	Conditions	MBRT30045(R)	MBRT30060(R)	MBRT30080(R)	MBRT300100(R)	Unit
Average forward current (per pkg)	$I_{F(AV)}$	$T_C = 125\text{ }^\circ\text{C}$	300	300	300	300	A
Peak forward surge current (per leg)	I_{FSM}	$t_p = 8.3\text{ ms}$, half sine	2000	2000	2000	2000	A
Maximum instantaneous forward voltage (per leg)	V_F	$I_{FM} = 150\text{ A}$, $T_j = 25\text{ }^\circ\text{C}$	0.70	0.75	0.84	0.84	V
Maximum instantaneous reverse current at rated DC blocking voltage (per leg)	I_R	$T_j = 25\text{ }^\circ\text{C}$	1	1	1	1	mA
		$T_j = 100\text{ }^\circ\text{C}$	10	10	10	10	
		$T_j = 150\text{ }^\circ\text{C}$	30	30	30	30	

Thermal characteristics

Thermal resistance, junction-case (per leg)	$R_{\theta JC}$		0.40	0.40	0.40	0.40	$^\circ\text{C/W}$
---	-----------------	--	------	------	------	------	--------------------

Figure.1-Typical Forward Characteristics

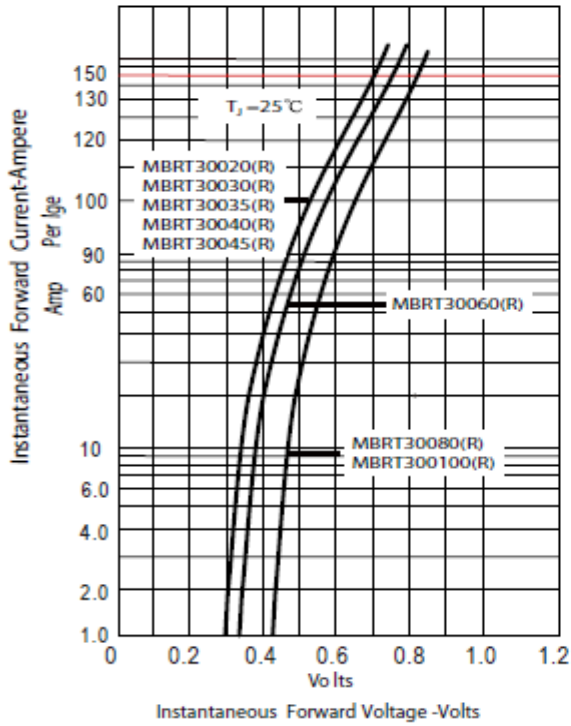

Figure.2-Forward Derating Curve

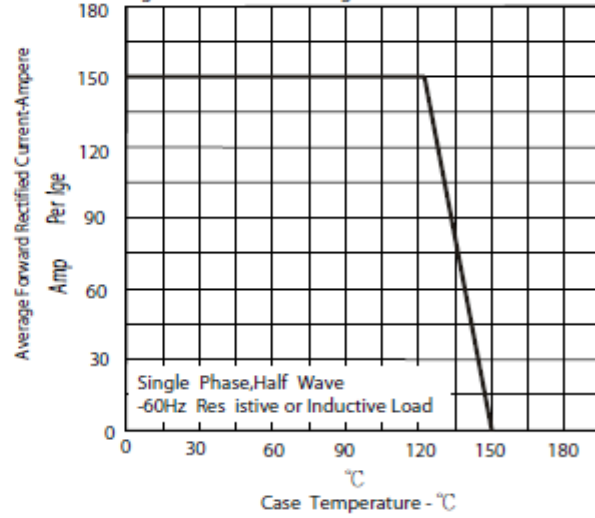

Figure.3-Peak Forward Surge Current

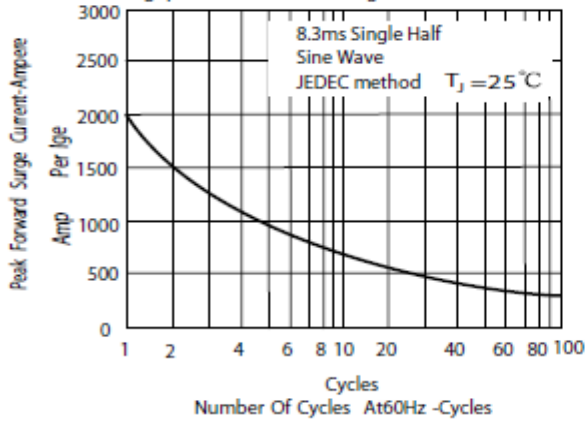
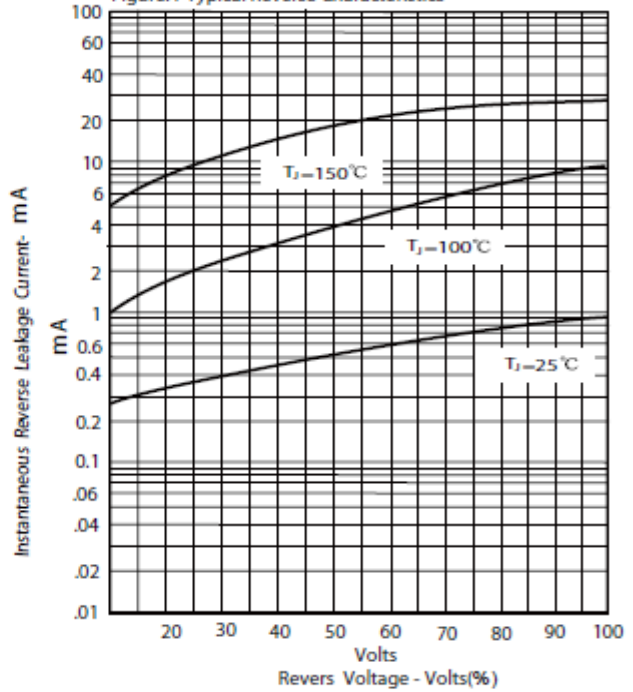
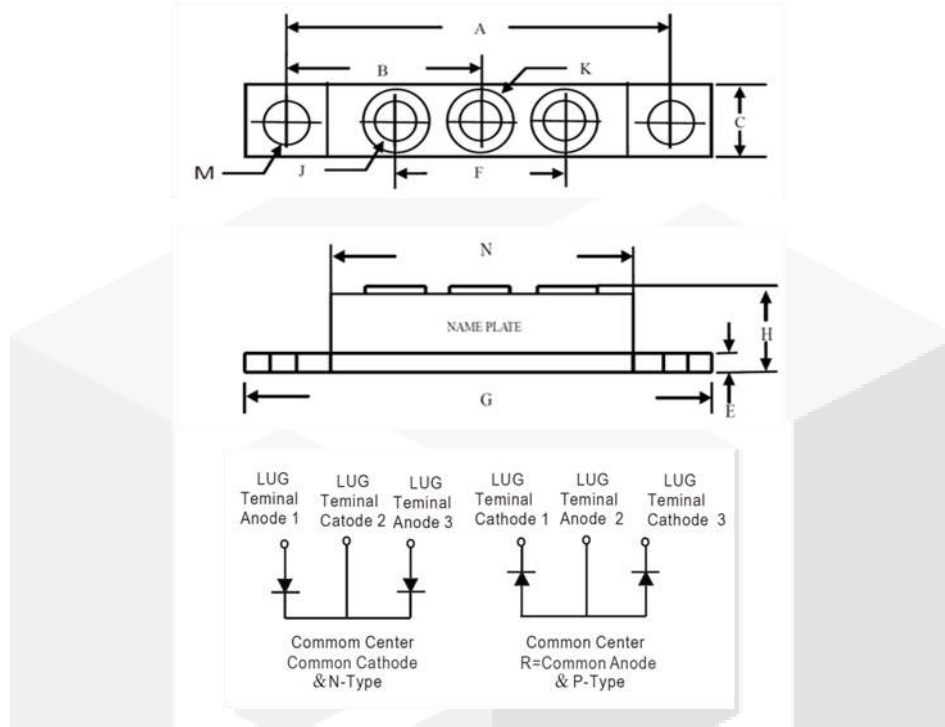

Figure.4-Typical Reverse Characteristics



Package dimensions and terminal configuration

Product is marked with part number and terminal configuration.



DIM	Inches		Millimeters	
	Min	Max	Min	Max
A	3.150	NOM	80.01	NOM
B	1.565	1.585	39.75	40.26
C	0.700	0.800	17.78	20.32
E	0.119	0.132	3.02	3.35
F	1.327	-----	33.72	-----
G	3.550	3.650	90.17	92.71
H	0.677	0.720	17.20	18.30
J	1/4 -20 UNC FULL			
K	0.472	0.511	12	13
M	0.275	0.295	6.99	7.49
N	2.380	2.460	60.5	62.5