

March 1997

1024 x 4 CMOS RAM

Features

- Low Power Standby 125µW Max
- Low Power Operation 35mW/MHz Max
- Data Retention at 2.0V Min
- TTL Compatible Input/Output
- Common Data Input/Output
- Three-State Output
- Standard JEDEC Pinout
- Fast Access Time..... 120/200ns Max
- 18 Pin Package for High Density
- On-Chip Address Register
- Gated Inputs - No Pull Up or Pull Down Resistors Required

Description

The HM-6514 is a 1024 x 4 static CMOS RAM fabricated using self-aligned silicon gate technology. The device utilizes synchronous circuitry to achieve high performance and low power operation.

On-chip latches are provided for addresses allowing efficient interfacing with microprocessor systems. The data output can be forced to a high impedance state for use in expanded memory arrays.

Gated inputs allow lower operating current and also eliminate the need for pull up or pull down resistors. The HM-6514 is a fully static RAM and may be maintained in any state for an indefinite period of time.

Data retention supply voltage and supply current are guaranteed over temperature.

Ordering Information

120ns	200ns	300ns	TEMPERATURE RANGE	PACKAGE	PKG. NO.
HM3-6514S-9	HM3-6514B-9	HM3-6514-9	-40°C to +85°C	PDIP	E18.3
HM1-6514S-9	HM1-6514B-9	HM1-6514-9	-40°C to +85°C	CERDIP	F18.3
24502BVA	-	-	-	JAN#	F18.3
8102402VA	8102404VA	8102406VA	-	SMD#	F18.3
-	-	-	-40°C to +85°C	CLCC	J18.B
-	-	HM4-6514-B	-55°C to +125°C		J18.B

Pinouts

HM-6514 (PDIP, CERDIP)
TOP VIEW

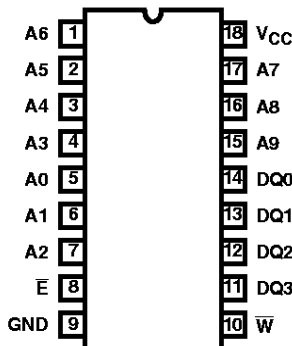

PIN	DESCRIPTION
A	Address Input
\bar{E}	Chip Enable
\bar{W}	Write Enable
D	Data Input
Q	Data Output

HM-6514 (CLCC)
TOP VIEW

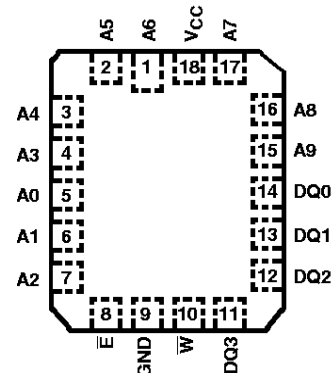

Functional Diagram

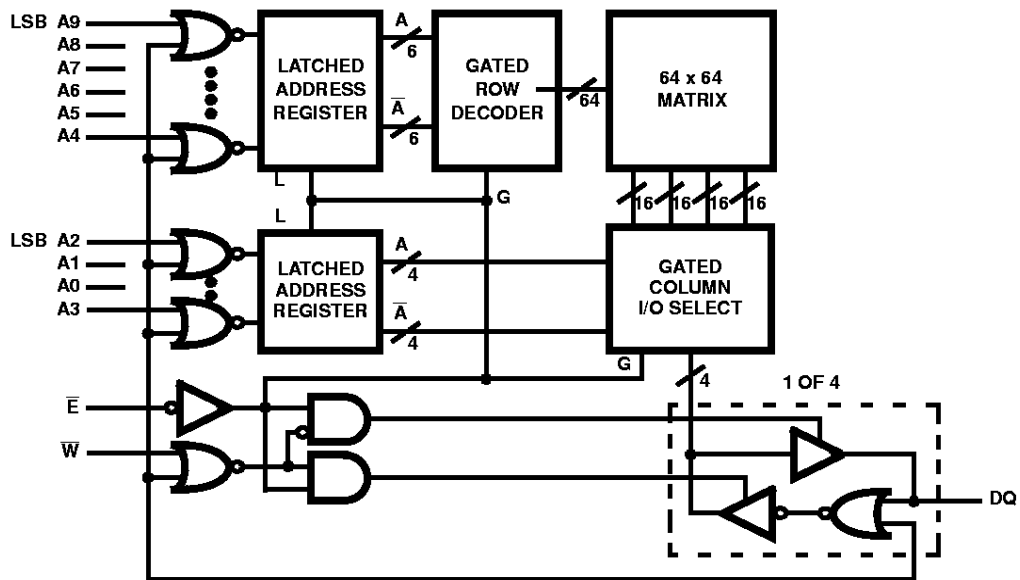

HM-6514

Absolute Maximum Ratings

Supply Voltage +7.0V
 Input, Output or I/O Voltage GND -0.3V to $V_{CC} + 0.3V$
 ESD Classification Class 1

Operating Conditions

Operating Voltage Range +4.5V to +5.5V
 Operating Temperature Ranges:
 HM-6514S-9, HM-6514B-9, HM-6514-9 -40°C to +85°C
 HM-6514B-8, HM-6514-8 -55°C to +125°C

Thermal Information

Thermal Resistance (Typical)	θ_{JA}	θ_{JC}
CERDIP Package	75°C/W	15°C/W
PDIP Package	75°C/W	N/A
CLCC Package	90°C/W	33°C/W
Maximum Storage Temperature Range	-65°C to +150°C	
Maximum Junction Temperature		
Ceramic Package	+175°C	
Plastic Package	+150°C	
Maximum Lead Temperature (Soldering 10s)	+300°C	

Die Characteristics

Gate Count 6910 Gates

CAUTION: Stresses above those listed in "Absolute Maximum Ratings" may cause permanent damage to the device. This is a stress only rating and operation of the device at these or any other conditions above those indicated in the operational sections of this specification is not implied.

DC Electrical Specifications $V_{CC} = 5V \pm 10\%$; $T_A = -40^\circ C$ to $+85^\circ C$ (HM-6514S-9, HM-6514B-9, HM-6514-9) $T_A = -55^\circ C$ to $+125^\circ C$ (HM-6514B-8, HM-6514-8)

SYMBOL	PARAMETER	LIMITS		UNITS	TEST CONDITIONS	
		MIN	MAX			
ICCSB	Standby Supply Current	HM-6514-9	-	25	μA	$I_O = 0mA$, $\bar{E} = V_{CC} - 0.3V$, $V_{CC} = 5.5V$
		HM-6514-8	-	50	μA	
ICCOP	Operating Supply Current (Note 1)	-	7	mA	$\bar{E} = 1MHz$, $I_O = 0mA$, $V_I = GND$, $V_{CC} = 5.5V$	
ICCDR	Data Retention Supply Current	HM-6514-9	-	15	μA	$I_O = 0mA$, $V_{CC} = 2.0V$, $\bar{E} = V_{CC}$
		HM-6514-8	-	25	μA	
VCCDR	Data Retention Supply Voltage	2.0	-	V		
II	Input Leakage Current	-1.0	+1.0	μA	$V_I = V_{CC}$ or GND, $V_{CC} = 5.5V$	
IIOZ	Input/Output Leakage Current	-1.0	+1.0	μA	$V_{IO} = V_{CC}$ or GND, $V_{CC} = 5.5V$	
VIL	Input Low Voltage	-0.3	0.8	V	$V_{CC} = 4.5V$	
VIH	Input High Voltage	$V_{CC} - 2.0$	$V_{CC} + 0.3$	V	$V_{CC} = 5.5V$	
VOL	Output Low Voltage	-	0.4	V	$I_O = 2.0mA$, $V_{CC} = 4.5V$	
VOH1	Output High Voltage	2.4	-	V	$I_O = -1.0mA$, $V_{CC} = 4.5V$	
VOH2	Output High Voltage (Note 2)	$V_{CC} - 0.4$	-	V	$I_O = -100\mu A$, $V_{CC} = 4.5V$	

Capacitance $T_A = +25^\circ C$

SYMBOL	PARAMETER	MAX	UNITS	TEST CONDITIONS
CI	Input Capacitance (Note 2)	8	pF	$f = 1MHz$, All measurements are referenced to device GND
CIO	Input/Output Capacitance (Note 2)	10	pF	

NOTES:

1. Typical derating 5mA/MHz increase in ICCOP.
2. Tested at initial design and after major design changes.

HM-6514

AC Electrical Specifications $V_{CC} = 5V \pm 10\%$; $T_A = -40^\circ\text{C}$ to $+85^\circ\text{C}$ (HM-6514S-9, HM-6514B-9, HM-6514-9)
 $T_A = -55^\circ\text{C}$ to $+125^\circ\text{C}$ (HM-6514B-8, HM-6514-8)

SYMBOL	PARAMETER	LIMITS						UNITS	TEST CONDITIONS
		HM-6514S-9		HM-6514B-9		HM-6514-9			
		MIN	MAX	MIN	MAX	MIN	MAX		
(1) TELQV	Chip Enable Access Time	-	120	-	220	-	300	ns	(Notes 1, 3)
(2) TAVQV	Address Access Time	-	120	-	220	-	320	ns	(Notes 1, 3, 4)
(3) TELQX	Chip Enable Output Enable Time	5	-	5	-	5	-	ns	(Notes 2, 3)
(4) TEHQZ	Chip Enable Output Disable Time	-	50	-	80	-	100	ns	(Notes 2, 3)
(5) TELEH	Chip Enable Pulse Negative Width	120	-	200	-	300	-	ns	(Notes 1, 3)
(6) TEHEL	Chip Enable Pulse Positive Width	50	-	90	-	120	-	ns	(Notes 1, 3)
(7) TAVEL	Address Setup Time	0	-	20	-	20	-	ns	(Notes 1, 3)
(8) TELAX	Address Hold Time	40	-	50	-	50	-	ns	(Notes 1, 3)
(9) TWLWH	Write Enable Pulse Width	120	-	200	-	300	-	ns	(Notes 1, 3)
(10) TWLEH	Chip Enable Write Pulse Setup Time	120	-	200	-	300	-	ns	(Notes 1, 3)
(11) TELWH	Chip Enable Write Pulse Hold Time	120	-	200	-	300	-	ns	(Notes 1, 3)
(12) TDVWH	Data Setup Time	50	-	120	-	200	-	ns	(Notes 1, 3)
(13) TWHDX	Data Hold Time	0	-	0	-	0	-	ns	(Notes 1, 3)
(14) TWLDV	Write Data Delay Time	70	-	80	-	100	-	ns	(Notes 1, 3)
(15) TWLEL	Early Output High-Z Time	0	-	0	-	0	-	ns	(Notes 1, 3)
(16) TEHWH	Late Output High-Z Time	0	-	0	-	0	-	ns	(Notes 1, 3)
(17) TELEL	Read or Write Cycle Time	170	-	290	-	420	-	-	(Notes 1, 3)

NOTES:

1. Input pulse levels: 0.8V to $V_{CC} - 2.0V$; Input rise and fall times: 5ns (max); Input and output timing reference level: 1.5V; Output load: 1 TTL gate equivalent, $C_L = 50\text{pF}$ (min) - for C_L greater than 50pF, access time is derated by 0.15ns per pF.
2. Tested at initial design and after major design changes.
3. $V_{CC} = 4.5V$ and 5.5V.
4. TAVQV = TELQV + TAVEL.

Timing Waveforms

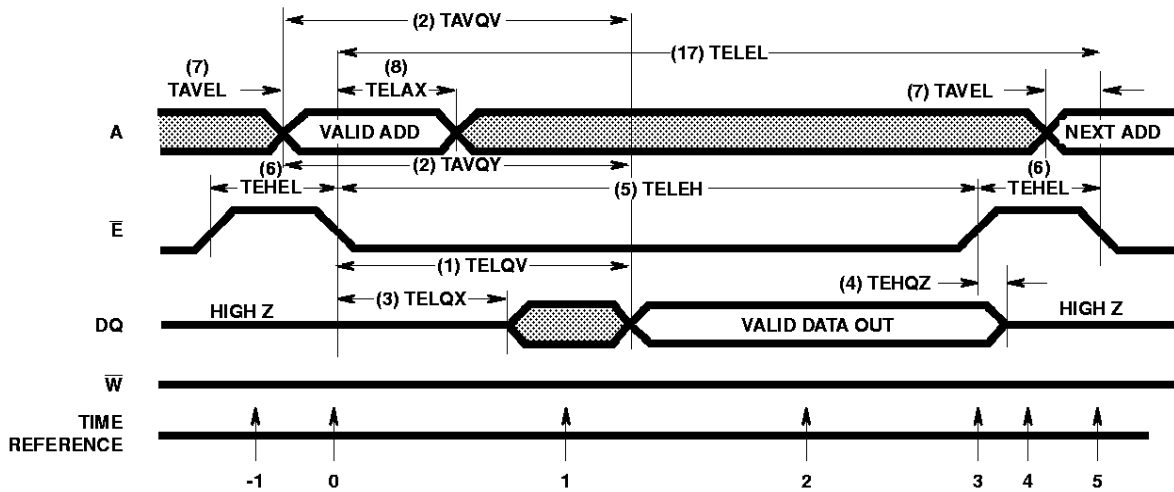

FIGURE 1. READ CYCLE

TRUTH TABLE

TIME REFERENCE	INPUTS			DATA I/O DQ	FUNCTION
	\bar{E}	\bar{W}	A		
-1	H	X	X	Z	Memory Disabled
0		H	V	Z	Cycle Begins, Addresses are Latched
1	L	H	X	X	Output Enabled
2	L	H	X	V	Output Valid
3		H	X	V	Read Accomplished
4	H	X	X	Z	Prepare for Next Cycle (Same as -1)
5		H	V	Z	Cycle Ends, Next Cycle Begins (Same as 0)

The address information is latched in the on-chip registers on the falling edge of \bar{E} (T = 0). Minimum address set up and hold time requirements must be met. After the required hold time, the addresses may change state without affecting device operation. During time (T = 1) the output becomes

enabled, but data is not valid until during time (T = 2). \bar{W} must remain high throughout the read cycle. After the output data has been read, \bar{E} may return high (T = 3). This will disable the output buffer and all inputs, and ready the RAM for the next memory cycle (T = 4).

Timing Waveforms (Continued)

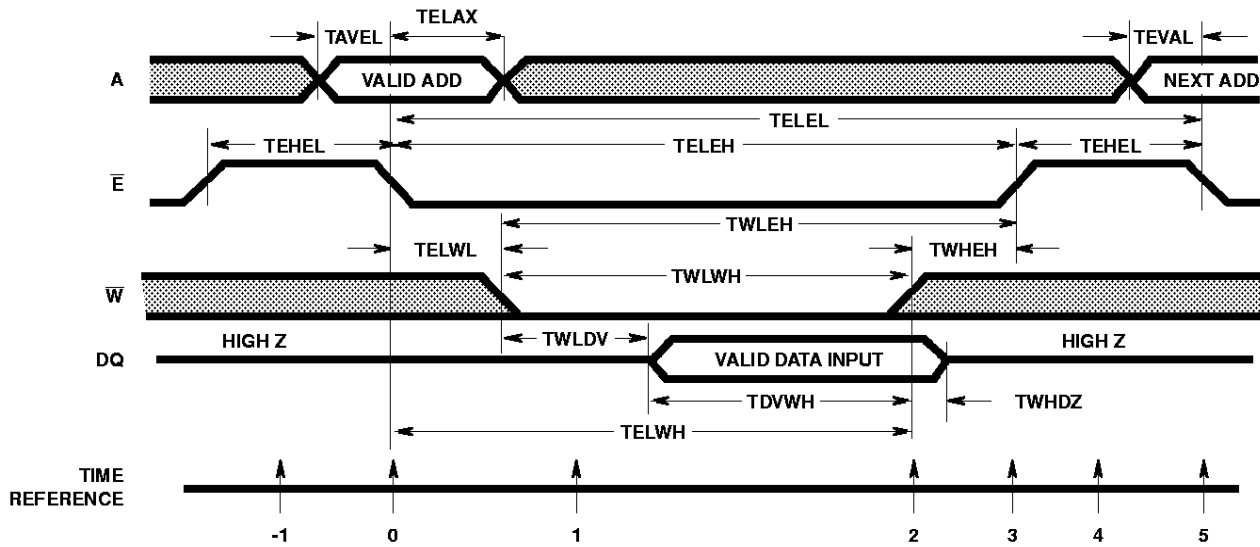

FIGURE 2. WRITE CYCLE TRUTH TABLE

TIME REFERENCE	INPUTS			DQ	FUNCTION
	\bar{E}	\bar{W}	A		
-1	H	X	X	Z	Memory Disabled
0	\downarrow	X	V	Z	Cycle Begins, Addresses are Latched
1	L	L	X	Z	Write Period Begins
2	L	\uparrow	X	V	Data In is Written
3	\uparrow	H	X	Z	Write Completed
4	H	X	X	Z	Prepare for Next Cycle (Same as -1)
5	\downarrow	X	V	Z	Cycle Ends, Next Cycle Begins (Same as 0)

The write cycle is initiated by the falling edge of \bar{E} ($T = 0$), which latches the address information in the on-chip registers. There are two basic types of write cycles, which differ in the control of the common data-in/data-out bus.

Case 1: \bar{E} falls before \bar{W} falls

The output buffers may become enabled (reading) if \bar{E} falls before \bar{W} falls. \bar{W} is used to disable (three-state) the outputs so input data can be applied. TWLDV must be met to allow the \bar{W} signal time to disable the outputs before applying input data. Also, at the end of the cycle the outputs may become active if \bar{W} rises before \bar{E} . The RAM outputs and all inputs will three-state after \bar{E} rises (TEHQZ). In this type of write cycle TWLEL and TEHWH may be ignored.

Case 2: \bar{E} falls equal to or after \bar{W} falls, and \bar{E} rises before or equal to \bar{W} rising

This \bar{E} and \bar{W} control timing will guarantee that the data outputs will stay disabled throughout the cycle, thus, simplifying the data input timing. TWLEL and TEHWH must be met, but TWLDV becomes meaningless and can be ignored. In this cycle TDVWH and TWHDX become TDVEH and TEHDX. In other words, reference data setup and hold times to the \bar{E} rising edge.

	IF	OBSERVE	IGNORE
Case 1	\bar{E} falls before \bar{W}	TWLDV	TWLEL
Case 2	\bar{E} falls after \bar{W} and \bar{E} rises before \bar{W}	TWLEL TEHWH	TWLDV TWHDX

If a series of consecutive write cycles are to be performed, \bar{W} may be held low until all desired locations have been written (an extension of Case 2).

Test Load Circuit

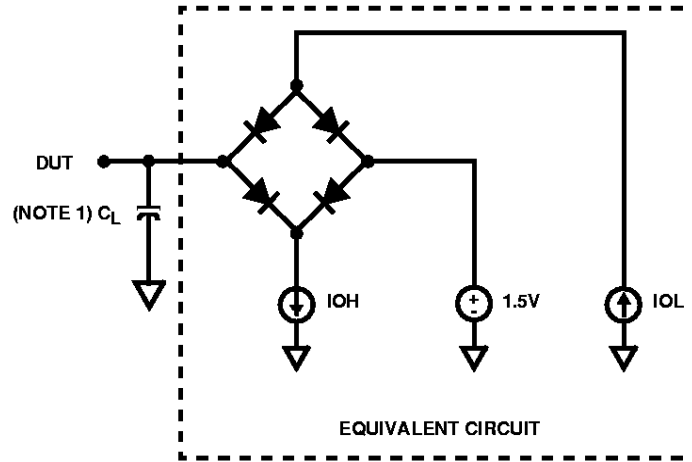

NOTE:

1. Test head capacitance.