

3.3V Phase-Lock Loop Clock Driver

General Description

The **ICS2510C** is a high performance, low skew, low jitter clock driver. It uses a phase lock loop (PLL) technology to align, in both phase and frequency, the CLKIN signal with the CLKOUT signal. It is specifically designed for use with synchronous SDRAMs. The **ICS2510C** operates at 3.3V VCC and drives up to ten clock loads.

One bank of ten outputs provide low-skew, low-jitter copies of CLKIN. Output signal duty cycles are adjusted to 50 percent, independent of the duty cycle at CLKIN. Outputs can be enabled or disabled via control (OE) inputs. When the OE inputs are high, the outputs align in phase and frequency with CLKIN; when the OE inputs are low, the outputs are disabled to the logic low state.

The **ICS2510C** does not require external RC filter components. The loop filter for the PLL is included on-chip, minimizing component count, board space, and cost. The test mode shuts off the PLL and connects the input directly to the output buffer. This test mode, the **ICS2510C** can be use as low skew fanout clock buffer device. The **ICS2510C** comes in 24 pin 173mil Thin Shrink Small-Outline package (TSSOP) package.

Features

- Meets or exceeds PC133 registered DIMM specification 1.1
- Spread Spectrum Clock Compatible
- Distributes one clock input to one bank of ten outputs
- Operating frequency 25MHz to 175MHz
- External feedback input (FBIN) terminal is used to synchronize the outputs to the clock input
- No external RC network required
- Operates at 3.3V Vcc
- Plastic 24-pin 173mil TSSOP package

Block Diagram

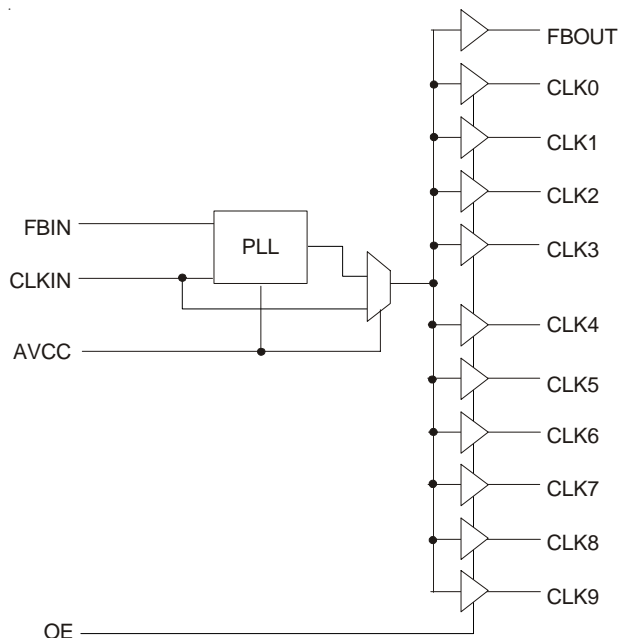

Pin Configuration

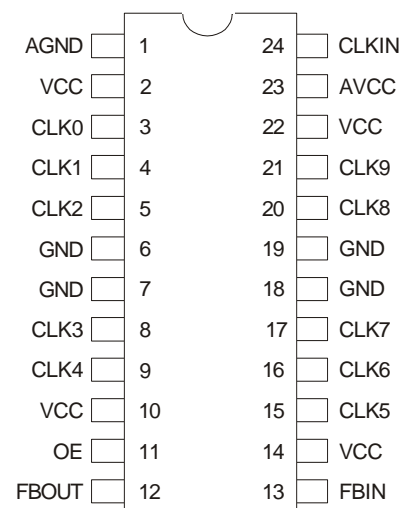

24 Pin TSSOP
4.40 mm. Body, 0.65 mm. pitch

Pin Descriptions

PIN NUMBER	PIN NAME	TYPE	DESCRIPTION
1	AGND	PWR	Analog Ground
2, 10, 14	VCC	PWR	Power Supply (3.3V)
3	CLK0	OUT	Buffered clock output.
4	CLK1	OUT	Buffered clock output.
5	CLK2	OUT	Buffered clock output.
6, 7, 18, 19	GND	PWR	Ground
8	CLK3	OUT	Buffered clock output.
9	CLK4	OUT	Buffered clock output.
11	OE ¹	IN	Output enable (has internal pull_up). When high, normal operation. When low, clock outputs are disabled to a logic low state.
12	FBOUT	OUT	Feedback output
13	FBIN	IN	Feedback input
15	CLK5	OUT	Buffered clock output.
16	CLK6	OUT	Buffered clock output.
17	CLK7	OUT	Buffered clock output.
20	CLK8	OUT	Buffered clock output.
21	CLK9	OUT	Buffered clock output.
22	VCC	PWR	Power Supply (3.3V) digital supply.
23	AVCC	IN	Analog power supply (3.3V). When input is ground PLL is off and bypassed.
24	CLKIN	IN	Clock input

Note:

1. Weak pull-ups on these inputs

Functionality

INPUTS		OUTPUTS			PLL
OE	AVCC	CLK (9:0)	FBOUT	Source	Shutdown
0	3.33	0	Driven	PLL	N
1	3.33	Driven	Driven	PLL	N
Buffer Mode					
0	0	0	Driven	CLKIN	Y
1	0	Driven	Driven	CLKIN	Y

Test mode:

When AVCC is 0, shuts off the PLL and connects the input directly to the output buffers

Absolute Maximum Ratings

Supply Voltage (AVCC)	AVCC < (V _{CC} + 0.7V)
Supply Voltage (VCC)	4.3 V
Logic Inputs	GND –0.5 V to V _{CC} +0.5 V
Ambient Operating Temperature	0°C to +70°C
Storage Temperature	–65°C to +150°C

Stresses above those listed under *Absolute Maximum Ratings* may cause permanent damage to the device. These ratings are stress specifications only and functional operation of the device at these or any other conditions above those listed in the operational sections of the specifications is not implied. Exposure to absolute maximum rating conditions for extended periods may affect product reliability.

Electrical Characteristics - OUTPUT

T_A = 0 - 70°C; V_{DD} = V_{DDL} = 3.3 V +/-10%; C_L = 20 - 30 pF; R_L = 470 Ohms (unless otherwise stated)

PARAMETER	SYMBOL	CONDITIONS	MIN	TYP	MAX	UNITS
Output Impedance	R _{DSP}	V _O = V _{DD} *(0.5)		36		Ω
Output Impedance	R _{DSN}	V _O = V _{DD} *(0.5)		32		Ω
Output High Voltage	V _{OH}	I _{OH} = -8 mA	2.4	2.9		V
Output Low Voltage	V _{OL}	I _{OL} = 8 mA		0.25	0.4	V
Output High Current	I _{OH}	V _{OH} = 2.4 V		-26	-13.6	mA
		V _{OH} = 2.0 V		-37	-22	
Output Low Current	I _{OL}	V _{OL} = 0.8 V	19	25		mA
		V _{OL} = 0.55 V	13	17		
Rise Time ¹	T _r	V _{OL} = 0.8 V, V _{OH} = 2.0 V	0.5	1.4	2.1	ns
Fall Time ¹	T _f	V _{OH} = 2.0 V, V _{OL} = 0.8 V	0.5	1.5	2.7	ns
Duty Cycle ¹	D _t	V _T = 1.5 V; C _L = 30 pF	45	50	55	%
Cycle to Cycle jitter ¹	T _{cyc-cyc}	at 66-100 MHz ; loaded outputs		52	100	ps
		at 133 MHz ; loaded outputs		39	75	
Absolute Jitter ¹	T _{jabs}	10000 cycles; C _L = 30 pF		57		ps
Skew ¹	T _{sk}	V _T = 1.5 V (Window) Output to Output		80	150	ps
Phase error ¹	T _{pe}	V _T = V _{dd} /2; CLKIN-FBIN	-150	40	150	ps
Phase error Jitter ¹	T _{pe} ³	V _T = V _{dd} /2; CLKIN-FBIN; Delay Jitter	-50	35	50	ps
Delay Input-Output ¹	D _{R1}	V _T = 1.5 V; PLL_EN = 0		3.3	3.7	ns

¹ Guaranteed by design, not 100% tested in production.

Electrical Characteristics - Input & Supply

$T_A = 0 - 70^\circ\text{C}$; Supply Voltage $V_{DD} = 3.3\text{ V} \pm 10\%$ (unless otherwise stated)

PARAMETER	SYMBOL	CONDITIONS	MIN	TYP	MAX	UNITS
Input High Voltage	V_{IH}		2		$V_{DD} + 0.3$	V
Input Low Voltage	V_{IL}		$V_{SS} - 0.3$		0.8	V
Input High Current	I_{IH}	$V_{IN} = V_{DD}$		0.1	100	μA
Input Low Current	I_{IL}	$V_{IN} = 0\text{ V}$;		19	50	μA
Operating current	I_{DD1}	$C_L = 0\text{ pF}$; $F_{IN} @ 66\text{M}$		140	170	mA
Input Capacitance	C_{IN}^1	Logic Inputs		4		pF
Output Capacitance	C_O^1	Logic Outputs		8		pF

¹Guaranteed by design, not 100% tested in production.

Timing requirements over recommended ranges of supply voltage and operating free-air temperature

Symbol	Parameter	Test Conditions	Min.	Max.	Unit
Fclk	Input clock frequency		25	175	MHz
	Input clock frequency duty cycle		40	60	%
	Stabilization time	After power up		1	ms

Note: Time required for the PLL circuit to obtain phase lock of its feedback signal to its In order for phase lock to be obtained, a fixed-frequency, fixed-phase reference signal Until phase lock is obtained, the specifications for parameters given in the switching

PARAMETER MEASUREMENT INFORMATION

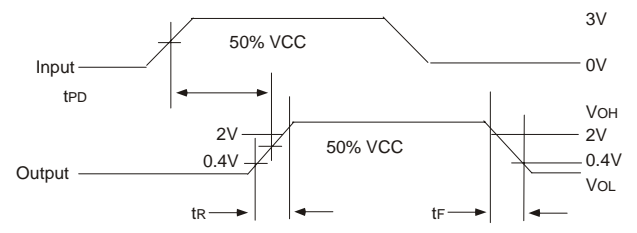
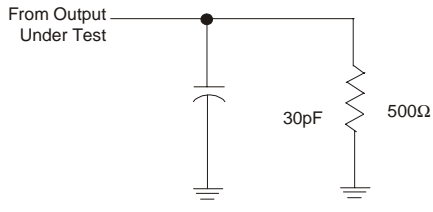

Figure 1. Load Circuit for Outputs

Notes:

1. C_L includes probe and jig capacitance.
2. All input pulses are supplied by generators having the following characteristics: PRR ≤133 MHz, Z_O = 50Ω, T_r ≤1.2 ns, T_f ≤1.2 ns.
3. The outputs are measured one at a time with one transition per measurement.

Figure 2. Voltage Waveforms Propagation Delay Times

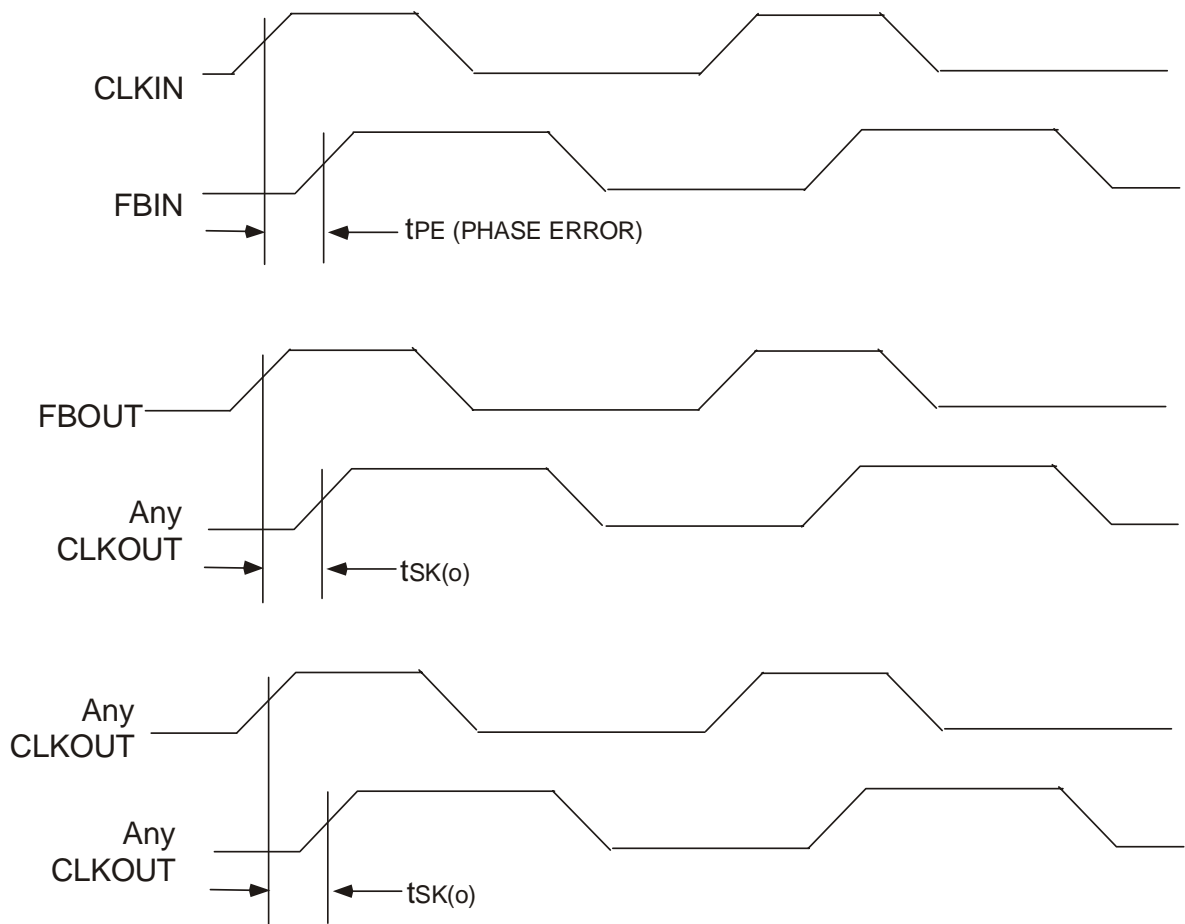

Figure 3. Phase Error and Skew Calculations

General Layout Precautions:

An ICS2509C is used as an example. It is similar to the ICS2510C. The same rules and methods apply.

- 1) Use copper flooded ground on the top signal layer under the clock buffer. The area under U1 in figure 1 on the right is an example. Every ground pin goes to a ground via. The vias are not visible in figure 1.
- 2) Use power vias for power and ground. Vias 20 mil or larger in diameter have lower high frequency impedance. Vias for signals may be minimum drill size.
- 3) Make all power and ground traces are as wide as the via pad for lower inductance.
- 4) VAA for pin 23 has a low pass RC filter to decouple the digital and analog supplies. C9-12 may be replaced with a single low ESR (0.8 ohm or less) device with the same total capacitance. R2 may be replaced with a ferrite bead. The bead should have a DC resistance of at least 0.5 ohms. 1 ohm is better. It should have an impedance of at least 300 ohms at 100MHz. 600 ohms at 100MHz is better.
- 5) Notice that ground vias are never shared.
- 6) All VCC pins have a decoupling capacitor. Power is always routed from the plane connection via to the capacitor pad to the VCC pin on the clock buffer.
- 7) Component R1 is located at the clock source.
- 8) Component C1, if used, has the effect of adding delay.
- 9) Component C7, if used, has the effect of subtracting delay. Delaying the FBIn clock will cause the output clocks to be earlier. A more effective method is to use the propagation time of a trace between FBOut and FBIn.

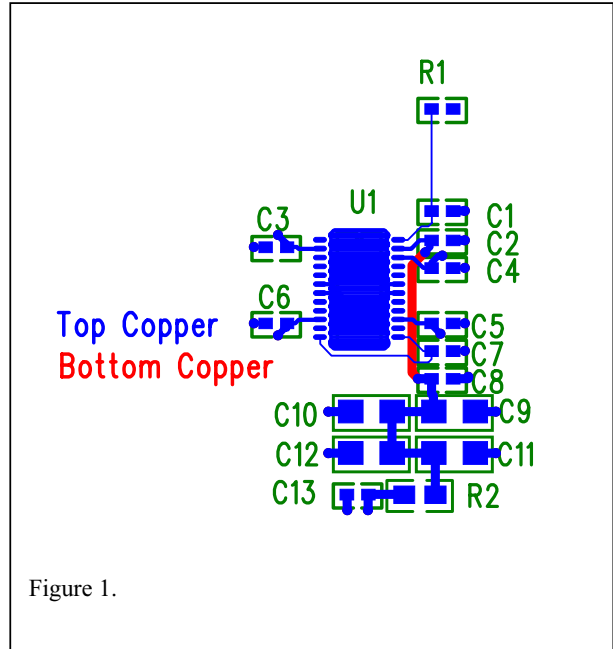
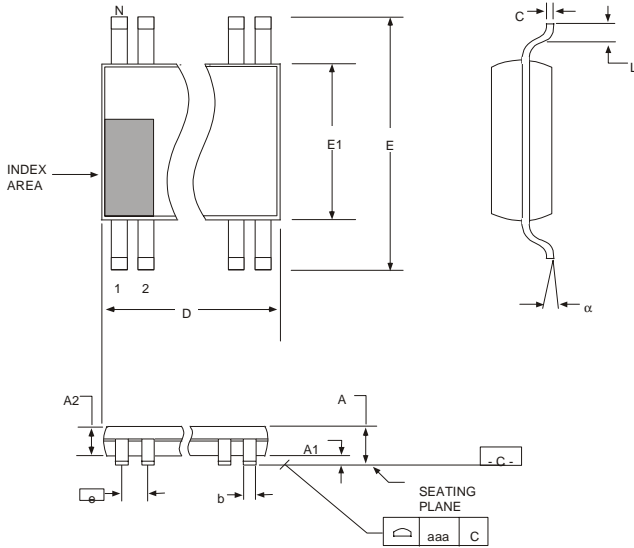

Figure 1.

Component Values:

C1, C7= As necessary for delay adjust
 C [6 : 2] = .01uF
 C8, C13=0.1uF
 C [12 : 9]=4.7uF
 R1=10 ohm. Locate at driver
 R2=10 ohm.



SYMBOL	In Millimeters		In Inches	
	COMMON DIMENSIONS	COMMON DIMENSIONS	COMMON DIMENSIONS	COMMON DIMENSIONS
A	--	1.20	--	.047
A1	0.05	0.15	.002	.006
A2	0.80	1.05	.032	.041
b	0.19	0.30	.007	.012
c	0.09	0.20	.0035	.008
D	SEE VARIATIONS		SEE VARIATIONS	
E	6.40 BASIC		0.252 BASIC	
E1	4.30	4.50	.169	.177
e	0.65 BASIC		0.0256 BASIC	
L	0.45	0.75	.018	.030
N	SEE VARIATIONS		SEE VARIATIONS	
alpha	0°	8°	0°	8°
aaa	--	0.10	--	.004

VARIATIONS

N	D mm.		D (inch)	
	MIN	MAX	MIN	MAX
24	7.70	7.90	.303	.311

Reference Doc.: JEDEC Publication 95, MO-153
10-0035

4.40 mm. Body, 0.65 mm. pitch TSSOP
(173 mil) (0.0256 Inch)

Ordering Information

2510CGLFT

Example:

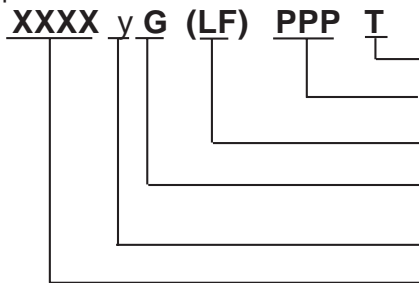

- Designation for tape and reel packaging**
- Pattern Number (2 or 3 digit number for parts with ROM code patterns)**
- Lead Free, RoHS Compliant (Optional)**
- Package Type**
G = TSSOP
- Revision Designator (will not correlate with datasheet revision)**
- Device Type**

IMPORTANT NOTICE AND DISCLAIMER

RENESAS ELECTRONICS CORPORATION AND ITS SUBSIDIARIES (“RENESAS”) PROVIDES TECHNICAL SPECIFICATIONS AND RELIABILITY DATA (INCLUDING DATASHEETS), DESIGN RESOURCES (INCLUDING REFERENCE DESIGNS), APPLICATION OR OTHER DESIGN ADVICE, WEB TOOLS, SAFETY INFORMATION, AND OTHER RESOURCES “AS IS” AND WITH ALL FAULTS, AND DISCLAIMS ALL WARRANTIES, EXPRESS OR IMPLIED, INCLUDING, WITHOUT LIMITATION, ANY IMPLIED WARRANTIES OF MERCHANTABILITY, FITNESS FOR A PARTICULAR PURPOSE, OR NON-INFRINGEMENT OF THIRD PARTY INTELLECTUAL PROPERTY RIGHTS.

These resources are intended for developers skilled in the art designing with Renesas products. You are solely responsible for (1) selecting the appropriate products for your application, (2) designing, validating, and testing your application, and (3) ensuring your application meets applicable standards, and any other safety, security, or other requirements. These resources are subject to change without notice. Renesas grants you permission to use these resources only for development of an application that uses Renesas products. Other reproduction or use of these resources is strictly prohibited. No license is granted to any other Renesas intellectual property or to any third party intellectual property. Renesas disclaims responsibility for, and you will fully indemnify Renesas and its representatives against, any claims, damages, costs, losses, or liabilities arising out of your use of these resources. Renesas' products are provided only subject to Renesas' Terms and Conditions of Sale or other applicable terms agreed to in writing. No use of any Renesas resources expands or otherwise alters any applicable warranties or warranty disclaimers for these products.

(Disclaimer Rev.1.0 Mar 2020)

Corporate Headquarters

TOYOSU FORESIA, 3-2-24 Toyosu,
Koto-ku, Tokyo 135-0061, Japan
www.renesas.com

Contact Information

For further information on a product, technology, the most up-to-date version of a document, or your nearest sales office, please visit:
www.renesas.com/contact/

Trademarks

Renesas and the Renesas logo are trademarks of Renesas Electronics Corporation. All trademarks and registered trademarks are the property of their respective owners.