

AZEV132

32 AMP POWER RELAY

FEATURES

- 32 Amp nominal switching capability
- Isolated N.C. signal contact for welding monitoring
- Withstands up to 1500 Amp short circuit current
- Wide contact gap of ≥ 2.25 mm
- Dielectric strength 4 kV_{RMS}
- UL / CUR E365652
- TÜV B0887930014
- CQC 19002216104



CONTACTS

Arrangement load contact signal contact	SPST-N.O. (1 Form A) SPST-N.C. (1 Form B) coupled to load contact
Ratings (max.) switched power switched current switched voltage signal contact	(resistive load) 12800 VA 32 A (40 A @ 45°C) 400 VAC 10 mA at 12 VDC
Rated Loads UL/CUR load contact signal contact	32 A at 277 VAC, resistive, 85°C, 50k cycles 40 A at 277 VAC, resistive, 45°C, 6k cycles 10 mA at 12 VDC, 85°C, 50k cycles
TÜV load contact signal contact	32 A at 400 VAC, resistive, 85°C, 50k cycles 40 A at 277 VAC, resistive, 45°C, 6k cycles 10 mA at 12 VDC, 85°C, 50k cycles
Contact material load contact signal contact	AgSnO ₂ (silver tin oxide) AgNi+Au (silver nickel, gold plated)
Contact gap load contact	≥ 2.25 mm
Contact resistance initial typical	(load contact) ≤ 50 m Ω < 3 m Ω

COIL

Nominal coil DC voltages	5, 9, 12, 24, 48
Dropout voltage	> 5% of nominal coil voltage
Holding voltage	> 35% of nominal coil voltage
Coil power nominal holding power at pickup voltage	(at 23 °C) 1.55 W 190 mW 875 mW
Temperature Rise	70 K (126°F) at nom. coil voltage, 85°C
Max. temperature	Class F insulation - 155°C (311°F)

GENERAL DATA

Life Expectancy mechanical electrical	(minimum operations) 1×10^5 see UL/CUR/TÜV ratings
Operate Time	30 ms (max.) at nominal coil voltage
Release Time	10 ms (max.) at nominal coil voltage, without coil suppression
Dielectric Strength coil to load contacts signal to load contacts open load contacts	(at sea level for 1 min.) 4000 V _{RMS} 4000 V _{RMS} 2500 V _{RMS}
Pulse current capability AZEV132	(based on requirements of IEC 62752) $\geq 1,50$ kA; ≥ 6.0 kA ² s
Insulation Resistance	1000 M Ω (min.) at 23°C, 500 VDC, 50% RH
Temperature Range operating	(at nominal coil voltage) -40°C (-40°F) to 85°C (185°F)
Vibration resistance	0.062" (1.5 mm) DA at 10–55 Hz
Enclosure protection category material group flammability	P.B.T. polyester RT II, flux proof IIIa UL94 V-0
Terminals	Tinned copper alloy, P. C.
Soldering max. temperature max. time	270 °C 5 s
Dimensions length width height	35.0 mm (1.38") 16.0 mm (0.63") 27.9 mm (1.10")
Weight	35 grams (approx.)
Compliance	UL 508, IEC 61810-1, RoHS, REACH designed to meet requirements of IEC 62752
Packing unit in pcs	50 per plastic tray / 400 per carton box

ZETTLER

AZEV132

COIL VOLTAGE SPECIFICATIONS

Nominal Coil VDC	Must Operate VDC	Min. Holding VDC	Max. Cont. VDC	Resistance Ohm \pm 10%
5	3.75	1.75	6.0	16.15
9	6.75	3.15	10.8	52.3
12	9.0	4.2	14.4	93.0
24	18.0	8.4	28.8	372
48	36.0	16.8	57.6	1488

Note: All values at 23°C (73°F), upright position, terminals downward.

ORDERING DATA

AZEV132-1AE - D

Nominal coil voltage
see coil voltage specifications table

Signal contact
nil: without signal contact
1BG: equipped with 1 Form B signal contact

Example ordering data

AZEV132-1AE-24D Without signal contact, 24 VDC coil

AZEV132-1AE1BG-12D With 1 Form B signal contact, 12 VDC coil

MECHANICAL DATA

Dimensions in mm.

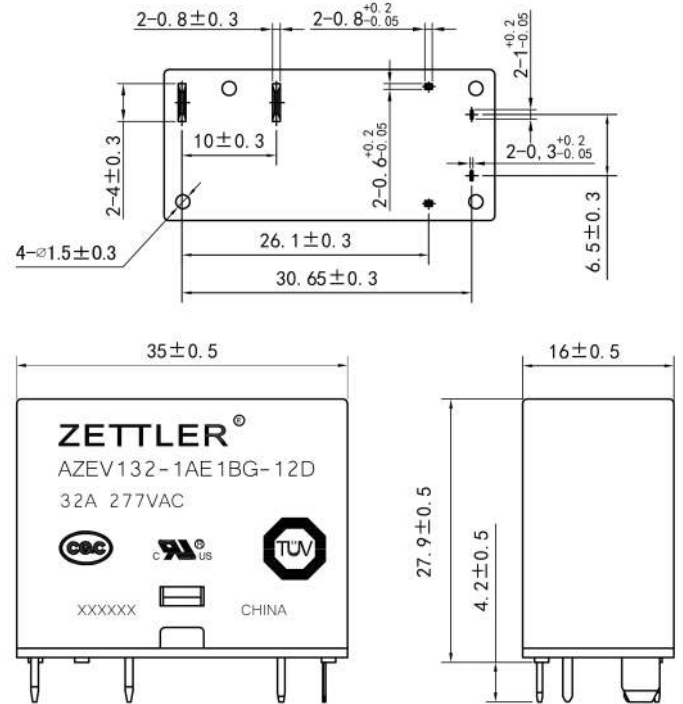

WIRING DIAGRAMS

Viewed towards terminals

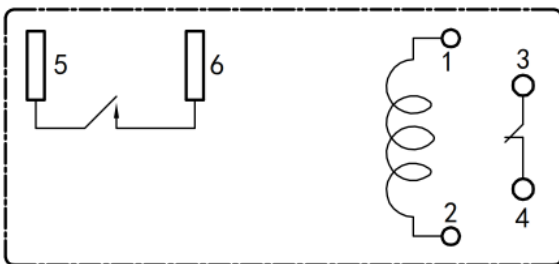

PC BOARD LAYOUT

Viewed towards terminals. Dimensions in mm.

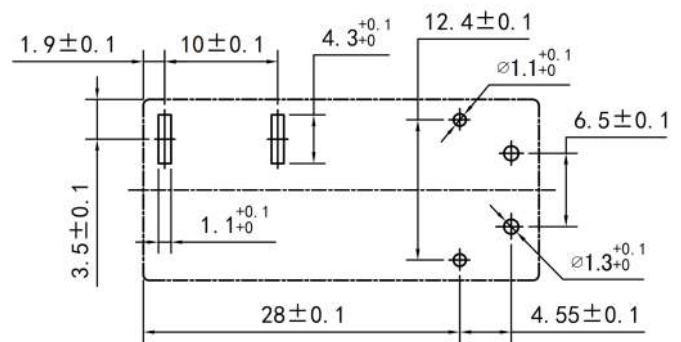

NOTES

1. All values at 23°C (73°F).
2. Relay may pull in with less than "Must Operate" value.
3. Provide sufficient PCB cross section as heat spreader on terminals.
4. Specifications subject to change without notice.

IEC62752 Short Circuit Withstand

Compliance with IEC62752 for short circuit withstand is a function of both relay design and PCB layout. ZETTLER's relay design and applications engineering teams have developed a set of applications notes that contain important design suggestions to optimize the performance of the AZEV132 relay with respect to its short circuit current withstand capability. Please contact your local ZETTLER relay office for these important application notes and suggestions.

In addition, as the overall performance depends on multiple factors such as part arrangement and trace routing, compliance cannot be generically guaranteed by ZETTLER. We strongly encourage customers to conduct their own short circuit tests in accordance with IEC62752 in the context of their individual application design.

ZETTLER

AZEV132

DISCLAIMER

This product specification is to be used in conjunction with the application notes which can be downloaded from the regional ZETTLER relay websites. The specification provides an overview of the most significant part features. Any individual applications and operating conditions are not taken into consideration. It is recommended to test the product under application conditions. Responsibility for the application remains with the customer. Proper operation and service life cannot be guaranteed if the part is operated outside the specified limits.

ZETTLER GROUP

Building on a foundation of more than a century of expertise in German precision engineering, ZETTLER Group is a world-class enterprise, engaged in the design, manufacturing, sales and distribution of electronic components. Our industry leadership is based on a unique combination of engineering competence and global scale.

For more information on other ZETTLER Group companies, please visit zettler-group.com. For support on this product or other ZETTLER relays, please visit one of the group sites below.

SITES FOR ZETTLER RELAYS

NORTH AMERICA

American Zettler, Inc.
www.azettler.com
sales@azettler.com

EUROPE

Zettler Electronics, GmbH
www.zettlerelectronics.com
office@zettlerelectronics.com

Zettler Electronics, Poland
www.zettlerelectronics.pl
office@zettlerelectronics.pl

CHINA

Zettler Group, China
www.zettlercn.com
relay@zettlercn.com

ASIA PACIFIC

Zettler Electronics (HK) Ltd.
www.zettlerhk.com
sales@zettlerhk.com



ZETTLER