

# GW J9LHS1.4M

## DURIS® E 5050

This 5050 RGBW device is the first 4-in-1 color package for general lighting applications from Osram Optosemiconductor. It features industry-compatible performance and form factor and promises outstanding reliability for customers. Each chip is individually controlled to enable high customization color options along with tight wavelength and color binning for excellent homogeneity.



## Applications

- Accent (BAR)
- Architecture
- Architecture / Garden Lighting (LED & Laser)
- Area Lights
- Hospitality
- Mood Lighting
- Smart Home, Metering

## Features:

- Package: Multi-color LED
- Typ. Radiation: 120° (Lambertian emitter)
- Color temperature: 3000K - 5700K
- ESD: 2 kV acc. to ANSI/ESDA/JEDEC JS-001 (HBM, Class 2)
- Industry Standard: RoHS and REACH
- Luminous Intensity: typ. 13000 mcd @ 3000K

## Ordering Information

Type	Color temperature	Ordering Code
GW J9LHS1.4M-C1C7-2+58+MQ+30A-1	3000 K	Q65113A1188
GW J9LHS1.4M-C1C7-2+58+MQ+40A-1	4000 K	Q65113A1187
GW J9LHS1.4M-C1C7-2+58+MQ+50A-1	5000 K	Q65113A1186
GW J9LHS1.4M-C1C7-2+58+MQ+57A-1	5700 K	Q65113A1185

Notes:

Standard Ordering Codes (Q-codes) will cover the entire wavelength, brightness and Vf specified in datasheet.

1. Wavelength: Customers will receive individual reels from any color bins specified in datasheet.
2. Brightness: Customers will receive individual reels from any brightness bins specified in datasheet.
3. Forward Voltage: Customer will receive individual reels from a single Vf bins specified in datasheet.

## BIN Description

**GW J9LHS1.4M-C1C7-2+58+MQ+30A-1**

Product name

Brightness bins

Red bins

Green bins

Blue bins

White CCT

One forward voltage group

## Maximum Ratings

Parameter	Symbol		Values	Values	Values	Values
			● red	● green	● blue	● white
Operating Temperature	$T_{op}$	min.	-40 °C	-40 °C	-40 °C	-40 °C
		max.	85 °C	85 °C	85 °C	85 °C
Storage Temperature	$T_{stg}$	min.	-40 °C	-40 °C	-40 °C	-40 °C
		max.	100 °C	100 °C	100 °C	100 °C
Junction Temperature	$T_j$	max.	110 °C	110 °C	110 °C	110 °C
Forward current	$I_F$	max.	200 mA	180 mA	180 mA	200 mA
Surge Current $T_j = 25\text{ °C}$	$I_{FS}$	max.	500 mA	400 mA	400 mA	240 mA
ESD withstand voltage acc. to ANSI/ESDA/ JEDEC JS-001 (HBM, Class 2)	$V_{ESD}$		2 kV	2 kV	2 kV	2 kV

## Characteristics

$I_F = 100 \text{ mA}$ ;  $T_J = 25 \text{ °C}$

Parameter	Symbol		Values	Values	Values	Values
			● red	● green	● blue	● white
Dominant Wave-length <sup>1)</sup> $I_F = 100 \text{ mA}$	$\lambda_{\text{dom}}$	min.	619.0 nm	525.0 nm	460.0 nm	
		max.	624.0 nm	535.0 nm	470.0 nm	
Spectral Bandwidth at 50% $I_{\text{rel,max}}$	$\Delta\lambda$	typ.	15.0 nm	29.0 nm	21.0 nm	
Viewing angle at 50% $I_V$	$2\phi$	typ.	120 °	120 °	120 °	120 °
Forward Voltage <sup>2)</sup> $I_F = 100 \text{ mA}$	$V_F$	min.	2.00 V	2.70 V	2.70 V	2.70 V
		typ.	2.10 V	3.00 V	3.10 V	3.00 V
		max.	2.70 V	3.80 V	3.80 V	3.80 V
Electrical thermal resistance junction/solderpoint with optical efficiency of each color	$R_{\text{thJS elec.}}$	typ.	26 K / W	41 K / W	27 K / W	32 K / W

Notes:

1. The product is not designed for reverse operation.
2. Efficiency of each color: Red 38%; Blue 43%; Green 25%; White 40%

## Brightness Groups

Color of emission	Group	Luminous Intensity <sup>3)</sup> $I_F = 100 \text{ mA}$ min. $I_v$	Luminous Intensity. <sup>3)</sup> $I_F = 100 \text{ mA}$ max. $I_v$
• red	C3	4500 mcd	6500 mcd
• red	C4	6500 mcd	8500 mcd
• red	C5	8500 mcd	10500 mcd
• green	C5	8500 mcd	10500 mcd
• green	C6	10500 mcd	14000 mcd
• green	C7	14000 mcd	17500 mcd
• blue	C1	2500 mcd	3500 mcd
• blue	C2	3500 mcd	4500 mcd
• blue	C3	4500 mcd	6500 mcd
• white	C5	8500 mcd	10500 mcd
• white	C6	10500 mcd	14000 mcd
• white	C7	14000 mcd	17500 mcd

### Forward Voltage Groups

- red

Group	Forward Voltage <sup>2)</sup> $I_F = 100 \text{ mA}$ min. $V_F$	Forward Voltage <sup>2)</sup> $I_F = 100 \text{ mA}$ max. $V_F$
A1	2.00 V	2.70 V

### Forward Voltage Groups

- green

Group	Forward Voltage <sup>2)</sup> $I_F = 100 \text{ mA}$ min. $V_F$	Forward Voltage <sup>2)</sup> $I_F = 100 \text{ mA}$ max. $V_F$
B1	2.70 V	3.80 V

### Forward Voltage Groups

- blue

Group	Forward Voltage <sup>2)</sup> $I_F = 100 \text{ mA}$ min. $V_F$	Forward Voltage <sup>2)</sup> $I_F = 100 \text{ mA}$ max. $V_F$
B1	2.70 V	3.80 V

### Forward Voltage Groups

- white

Group	Forward Voltage <sup>2)</sup> $I_F = 100 \text{ mA}$ min. $V_F$	Forward Voltage <sup>2)</sup> $I_F = 100 \text{ mA}$ max. $V_F$
B1	2.70 V	3.80 V

### Wavelength Groups

- red

Group	Dominant Wavelength <sup>1)</sup> $I_F = 100 \text{ mA}$ min. $\lambda_{\text{dom}}$	Dominant Wavelength <sup>1)</sup> $I_F = 100 \text{ mA}$ max. $\lambda_{\text{dom}}$
2	619.0 nm	624.0 nm

### Wavelength Groups

- green

Group	Dominant Wavelength <sup>1)</sup> $I_F = 100 \text{ mA}$ min. $\lambda_{\text{dom}}$	Dominant Wavelength <sup>1)</sup> $I_F = 100 \text{ mA}$ max. $\lambda_{\text{dom}}$
5	525.0 nm	527.5 nm
6	527.5 nm	530.0 nm
7	530.0 nm	532.5 nm
8	532.5 nm	535.0 nm

### Wavelength Groups

- blue

Group	Dominant Wavelength <sup>1)</sup> $I_F = 100 \text{ mA}$ min. $\lambda_{\text{dom}}$	Dominant Wavelength <sup>1)</sup> $I_F = 100 \text{ mA}$ max. $\lambda_{\text{dom}}$
M	460.0 nm	462.5 nm
N	462.5 nm	465.0 nm
P	465.0 nm	467.5 nm
Q	467.5 nm	470.0 nm



### Chromaticity Coordinate Groups

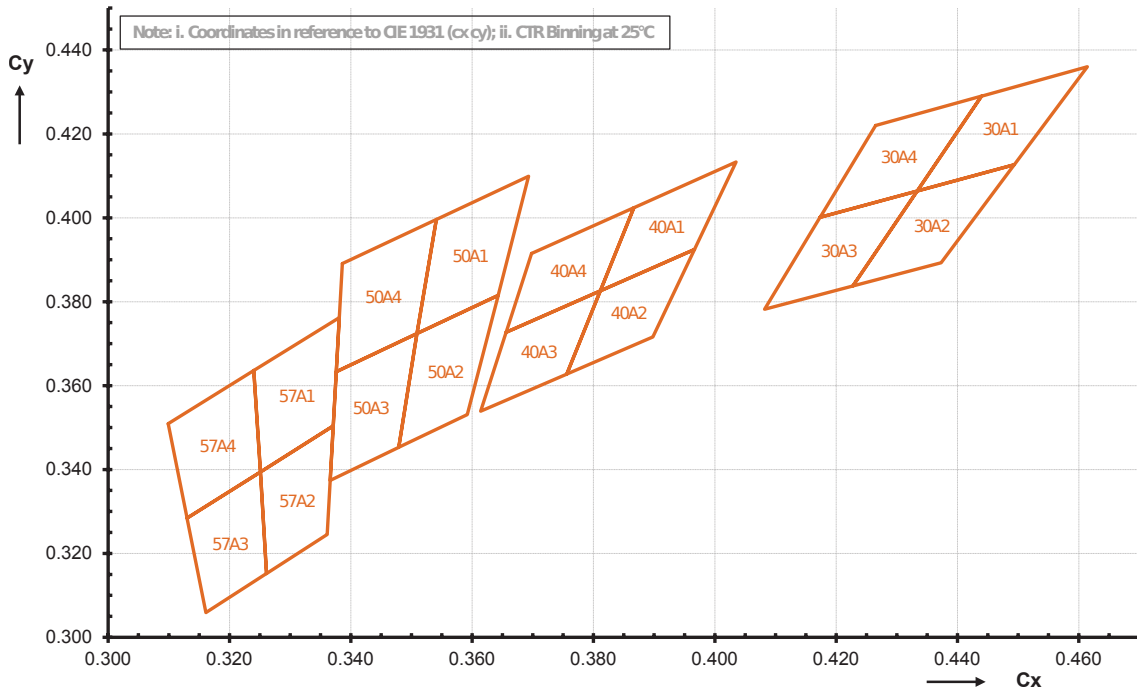

### Chromaticity Coordinate Groups

- white

Group	Cx	Cy	CCT
30A1	0.4614	0.4360	3000
	0.4494	0.4127	3000
	0.4334	0.4064	3000
	0.4440	0.4290	3000
30A2	0.4494	0.4127	3000
	0.4373	0.3893	3000
	0.4228	0.3838	3000
	0.4334	0.4064	3000
30A3	0.4334	0.4064	3000
	0.4228	0.3838	3000
	0.4082	0.3782	3000
	0.4174	0.4001	3000
30A4	0.4440	0.4290	3000
	0.4334	0.4064	3000
	0.4174	0.4001	3000
	0.4265	0.4220	3000

## Chromaticity Coordinate Groups

• white

Group	Cx	Cy	CCT
40A1	0.4035	0.4133	4000
	0.3967	0.3925	4000
	0.3811	0.3826	4000
	0.3867	0.4024	4000
40A2	0.3967	0.3925	4000
	0.3898	0.3716	4000
	0.3756	0.3628	4000
	0.3811	0.3826	4000
40A3	0.3811	0.3826	4000
	0.3756	0.3628	4000
	0.3614	0.3539	4000
	0.3656	0.3727	4000
40A4	0.3867	0.4024	4000
	0.3811	0.3826	4000
	0.3656	0.3727	4000
	0.3698	0.3915	4000
50A1	0.3693	0.4099	5000
	0.3643	0.3815	5000
	0.3509	0.3724	5000
	0.3541	0.3996	5000
50A2	0.3643	0.3815	5000
	0.3592	0.3531	5000
	0.3479	0.3453	5000
	0.3509	0.3724	5000
50A3	0.3509	0.3724	5000
	0.3479	0.3453	5000
	0.3366	0.3374	5000
	0.3376	0.3633	5000
50A4	0.3541	0.3996	5000
	0.3509	0.3724	5000
	0.3376	0.3633	5000
	0.3386	0.3891	5000

## Chromaticity Coordinate Groups

• white

Group	Cx	Cy	CCT
57A1	0.3381	0.3762	5700
	0.3371	0.3504	5700
	0.3251	0.3394	5700
	0.3240	0.3636	5700
57A2	0.3371	0.3504	5700
	0.3361	0.3245	5700
	0.3261	0.3152	5700
	0.3251	0.3394	5700
57A3	0.3251	0.3394	5700
	0.3261	0.3152	5700
	0.3161	0.3059	5700
	0.3130	0.3284	5700
57A4	0.3240	0.3636	5700
	0.3251	0.3394	5700
	0.3130	0.3284	5700
	0.3099	0.3509	5700

## Group Name on Label

Example: C3-2+C5-5+C1-M+C5-30A1

Color	Brightness
● red	C3
● green	C5
● blue	C1
● white	C5

**Relative Spectral Emission** 4)

$I_{rel} = f(\lambda); I_F = 100 \text{ mA}; T_J = 25 \text{ }^\circ\text{C}$

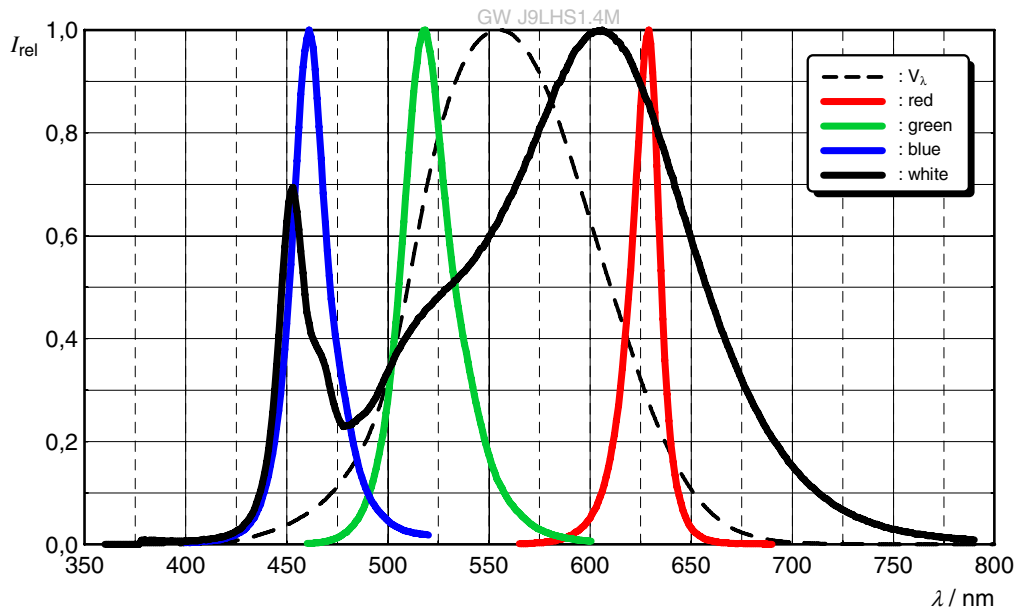

**Radiation Characteristic (horizontal)** 4)

$I_{rel} = f(\phi); T_J = 25 \text{ }^\circ\text{C}$

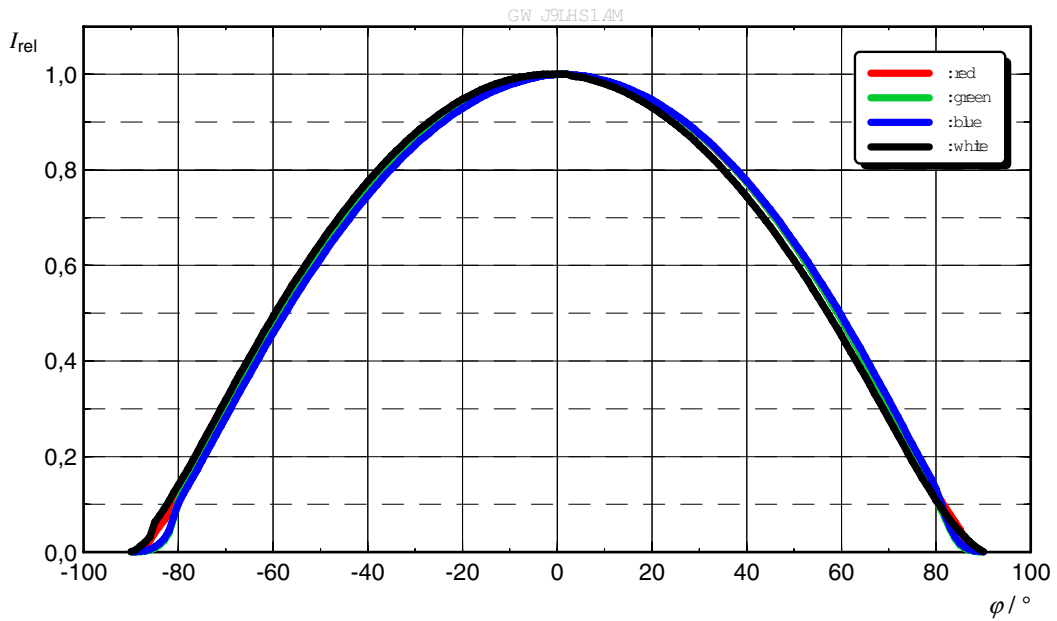

**Radiation Characteristic (vertical)** <sup>4)</sup>

$I_{rel} = f(\phi); T_J = 25\text{ °C}$

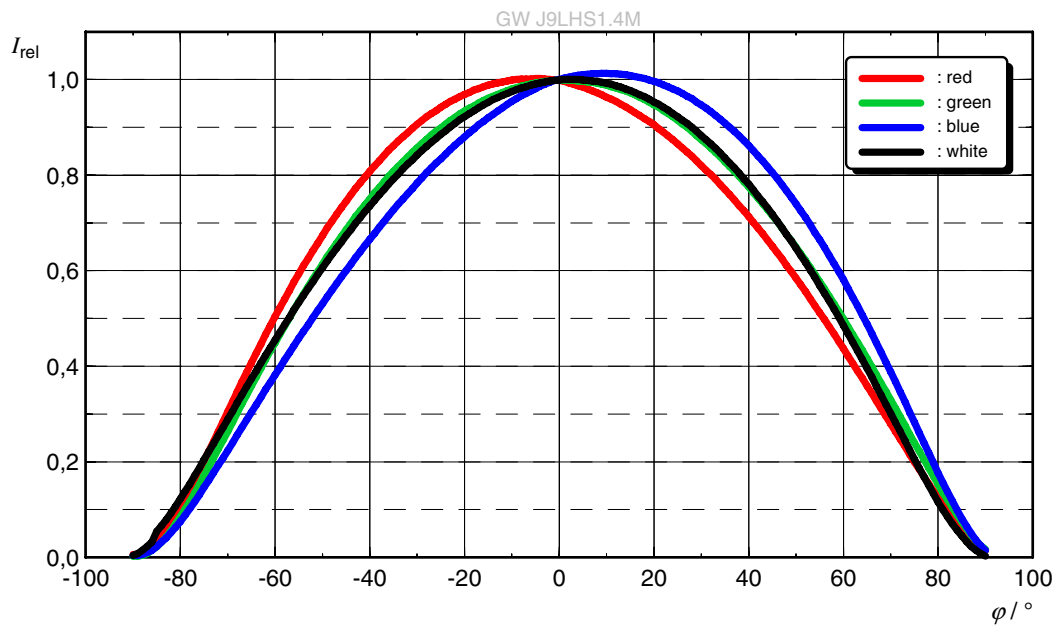

**Forward current** 4)

$I_F = f(V_F); T_J = 25\text{ }^\circ\text{C}$

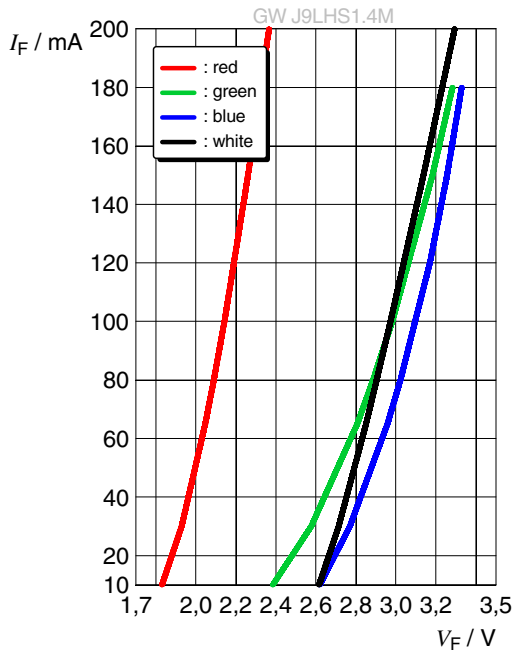

**Relative Luminous Flux** 4), 5)

$I_V/I_V(100\text{ mA}) = f(I_F); T_J = 25\text{ }^\circ\text{C}$

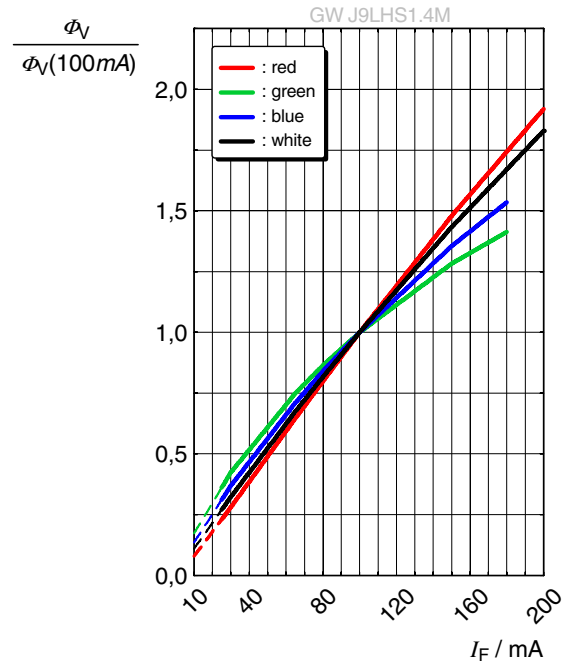

**Chromaticity Coordinate Shift** 4)

$\Delta Cx, \Delta Cy = f(I_F); T_J = 25\text{ }^\circ\text{C}$

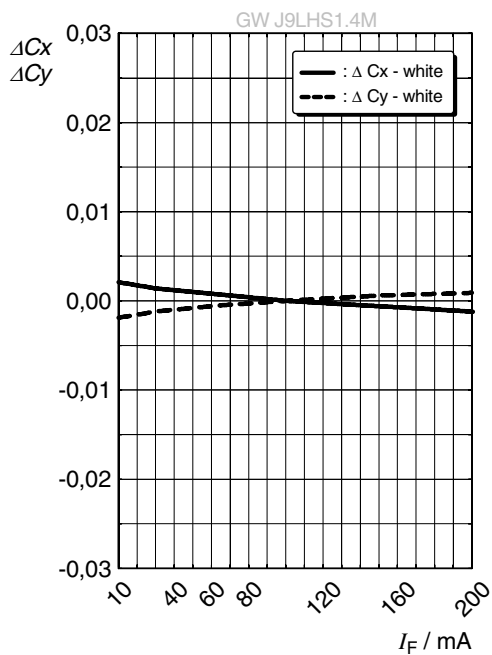

**Dominant Wavelength** 4)

$\Delta \lambda_{dom} = f(I_F); T_J = 25\text{ }^\circ\text{C}$

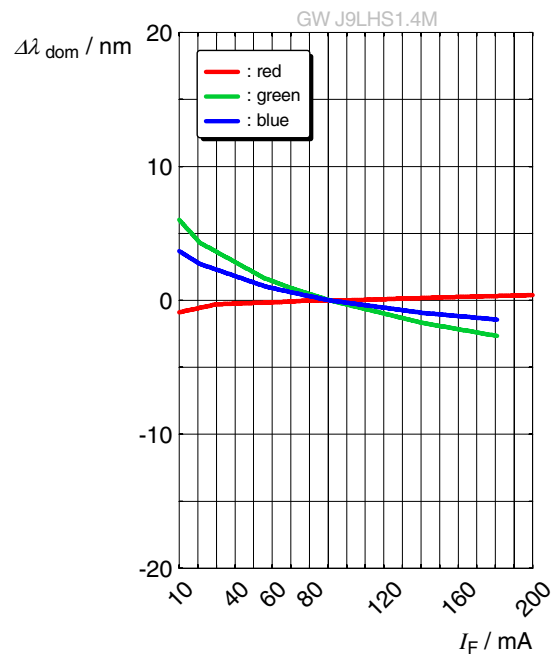

### Forward Voltage <sup>4)</sup>

$$\Delta V_F = V_F - V_F(25\text{ °C}) = f(T_j); I_F = 100\text{ mA}$$

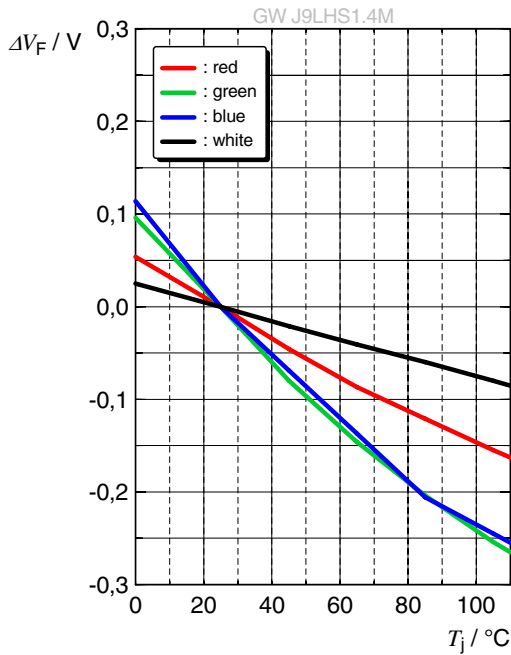

### Relative Luminous Flux <sup>4)</sup>

$$I_V / I_V(25\text{ °C}) = f(T_j); I_F = 100\text{ mA}$$

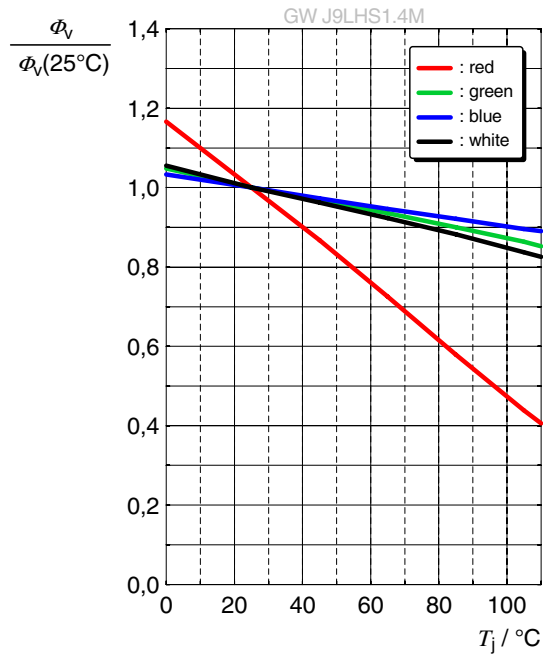

### Chromaticity Coordinate Shift <sup>4)</sup>

$$\Delta C_x, \Delta C_y = f(T_j); I_F = 100\text{ mA}$$

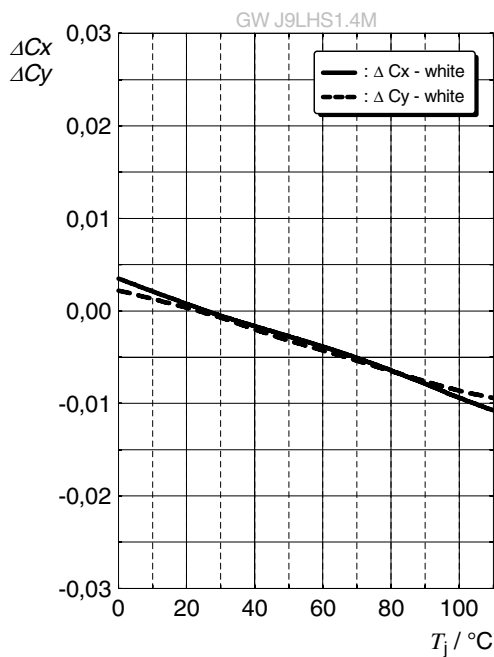

### Dominant Wavelength <sup>4)</sup>

$$\Delta \lambda_{\text{dom}} = \lambda_{\text{dom}} - \lambda_{\text{dom}}(25\text{ °C}) = f(T_j); I_F = 100\text{ mA}$$

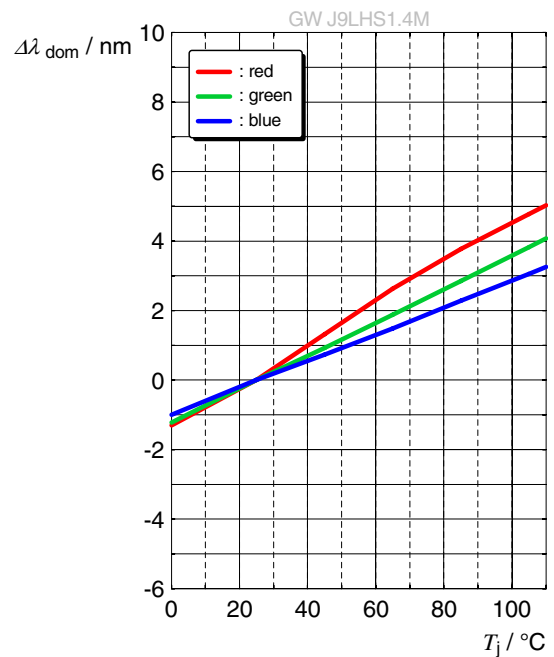



## Max. Permissible Forward Current

$I_F = f(T)$ ; • red

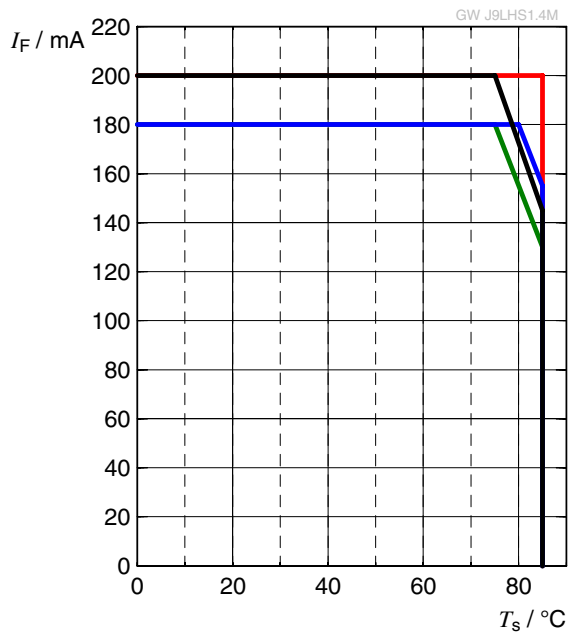

Dimensional Drawing <sup>6)</sup>

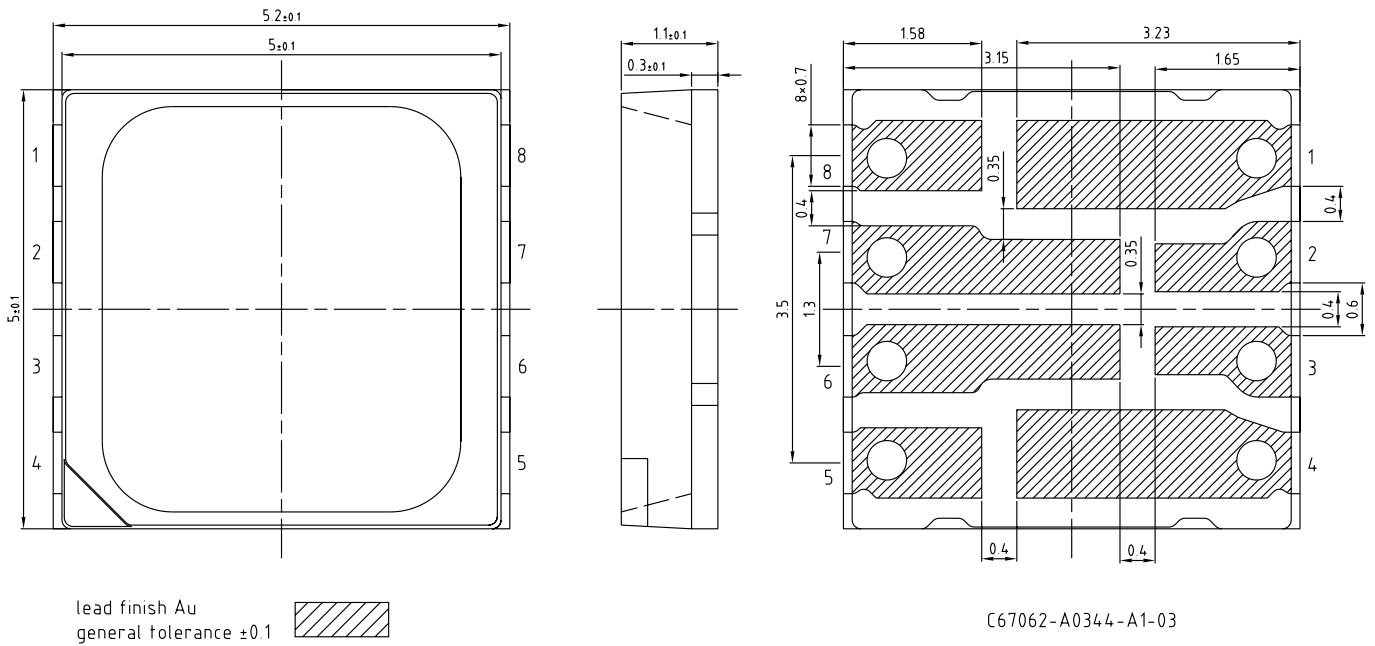

1	Anode Red (R)
8	Cathode Red (R)
2	Anode True Green (T)
7	Cathode True Green (T)
3	Anode Blue (B)
6	Cathode Blue (B)
4	Anode White (W)
5	Cathode White (W)

Further Information:

Approximate Weight: 73.0 mg

Package marking: Anode

Recommended Solder Pad <sup>6)</sup>

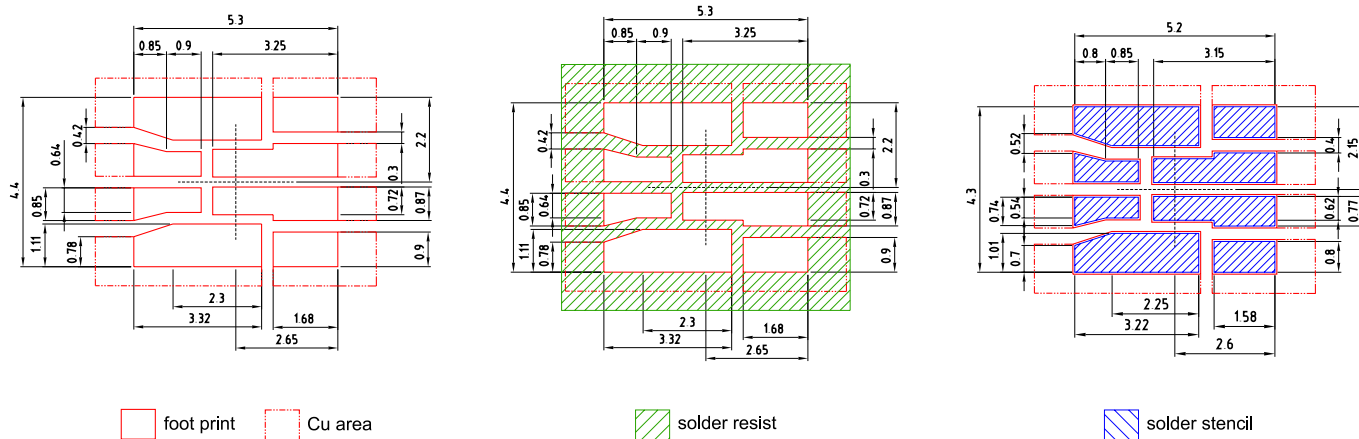

E067.0346.13-01

For superior solder joint connectivity results we recommend soldering under standard nitrogen atmosphere. Package not suitable for ultra sonic cleaning.

## Reflow Soldering Profile

Product complies to MSL Level 3 acc. to JEDEC J-STD-020E

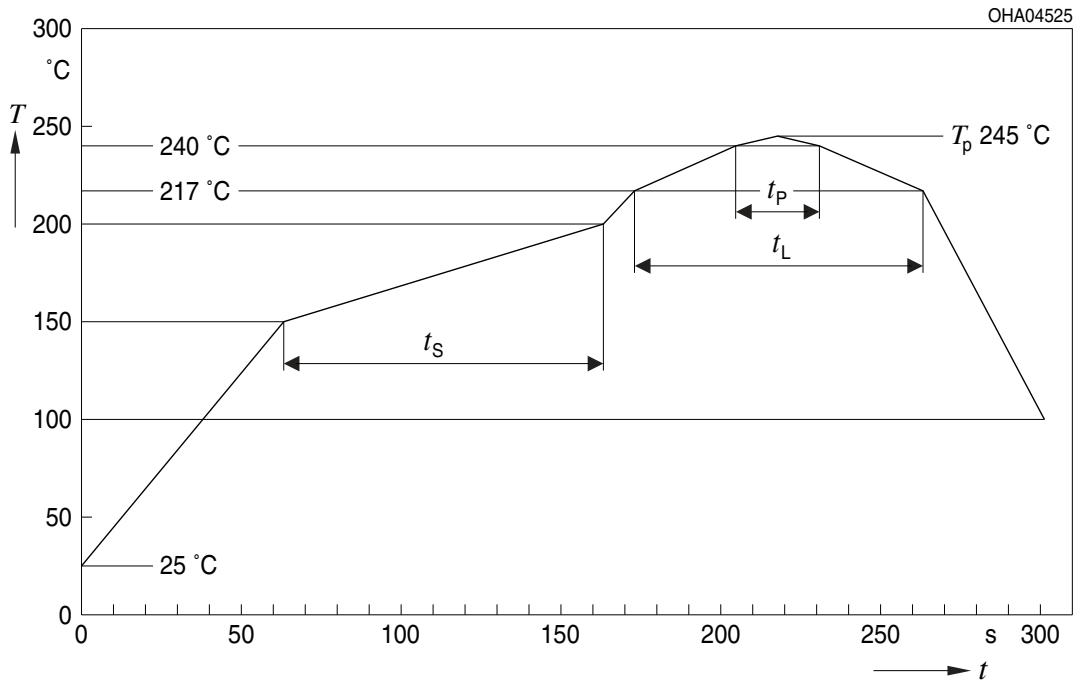

Profile Feature	Symbol	Pb-Free (SnAgCu) Assembly			Unit
		Minimum	Recommendation	Maximum	
Ramp-up rate to preheat <sup>*)</sup> 25 °C to 150 °C			2	3	K/s
Time $t_s$ $T_{Smin}$ to $T_{Smax}$	$t_s$	60	100	120	s
Ramp-up rate to peak <sup>*)</sup> $T_{Smax}$ to $T_p$			2	3	K/s
Liquidus temperature	$T_L$		217		°C
Time above liquidus temperature	$t_L$		80	100	s
Peak temperature	$T_p$		245	250	°C
Time within 5 °C of the specified peak temperature $T_p - 5$ K	$t_p$	10	20	30	s
Ramp-down rate* $T_p$ to 100 °C			3	4	K/s
Time 25 °C to $T_p$				480	s

All temperatures refer to the center of the package, measured on the top of the component

\* slope calculation  $DT/Dt$ :  $Dt$  max. 5 s; fulfillment for the whole T-range

Taping <sup>6)</sup>

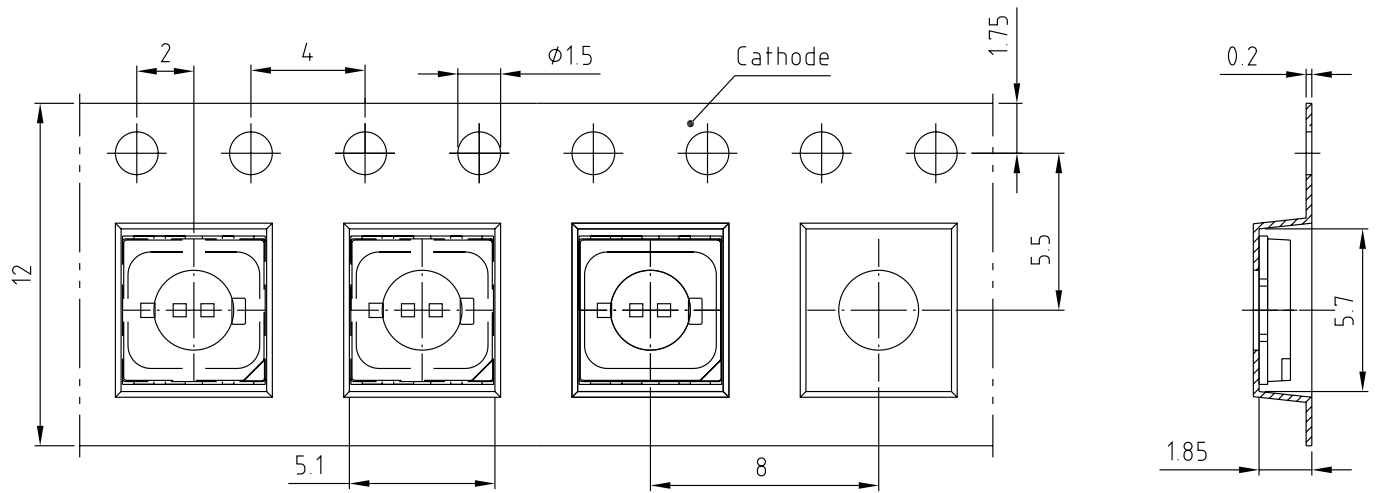

C67062-A0344-B1-03

## Tape and Reel <sup>7)</sup>

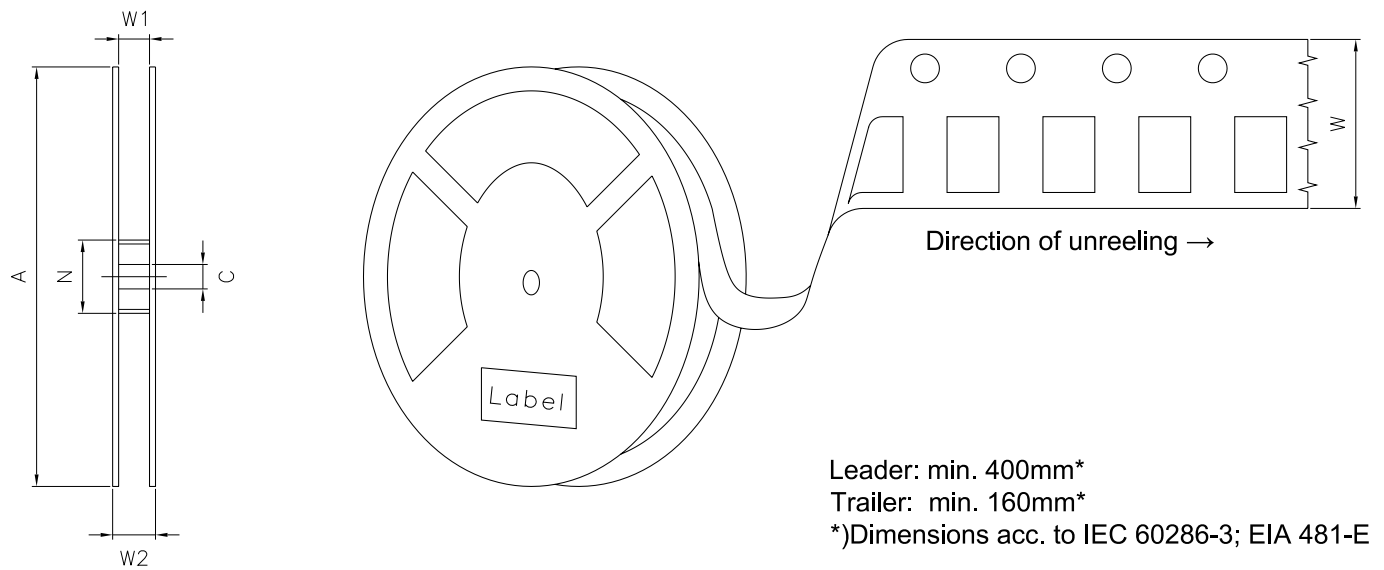

## Reel Dimensions

A	W	$N_{\min}$	$W_1$	$W_{2\max}$	Pieces per PU
180 mm	12 + 0.3 / - 0.1 mm	60 mm	12.4 + 2 mm	18.4 mm	1000

### Barcode-Product-Label (BPL)

**OSRAM Opto Semiconductors** LX XXXX BIN1: XX-XX-X-XXX-X

RoHS Compliant

(6P) BATCH NO: 1234567890

(1T) LOT NO: 1234567890 (9D) D/C: 1234

(X) PROD NO: 123456789(Q)QTY: 9999 (G) GROUP: XX-XX-X-X

ML Temp ST  
X XXX °C X

Pack: RXX  
DEMY XXX  
X\_X123\_1234.1234 X

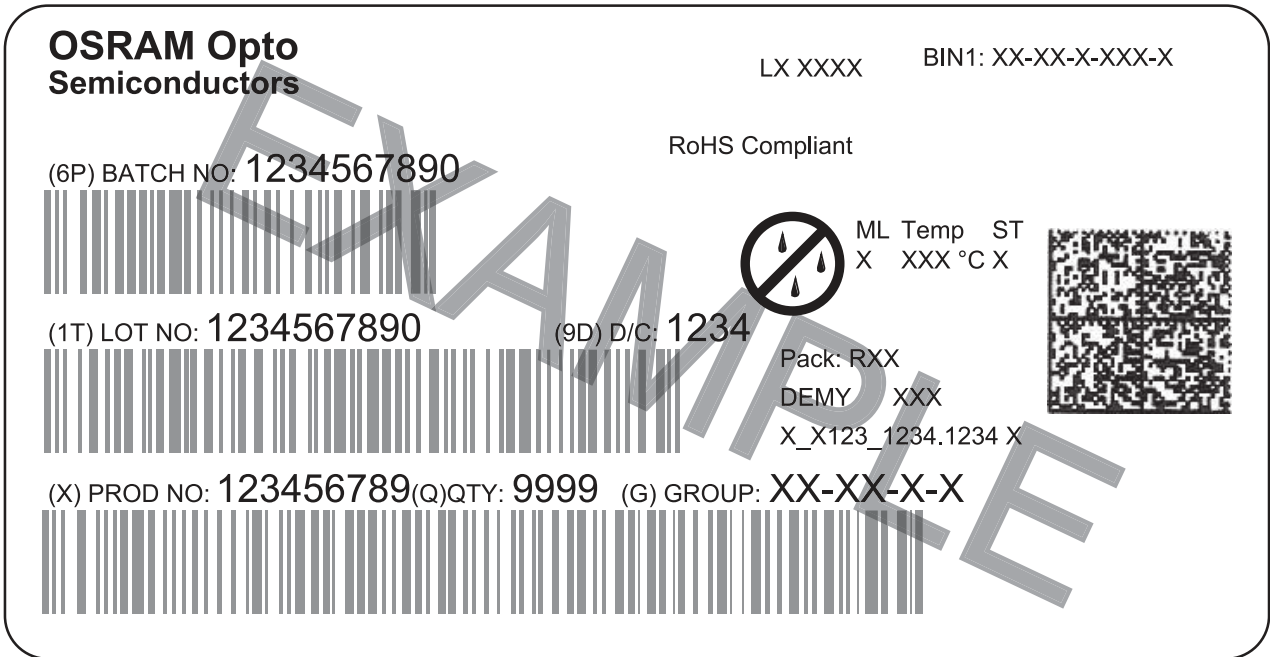

The diagram shows a rectangular label with rounded corners. It contains the OSRAM logo and company name at the top left. To the right are fields for 'LX XXXX' and 'BIN1: XX-XX-X-XXX-X'. Below the logo is the text 'RoHS Compliant'. The label features three horizontal barcode sections. The first is labeled '(6P) BATCH NO: 1234567890'. The second is labeled '(1T) LOT NO: 1234567890' and '(9D) D/C: 1234'. The third is labeled '(X) PROD NO: 123456789(Q)QTY: 9999' and '(G) GROUP: XX-XX-X-X'. To the right of the second barcode is a circular icon with a diagonal line and three raindrops, with the text 'ML Temp ST X XXX °C X' next to it. Below this icon is the text 'Pack: RXX', 'DEMY XXX', and 'X\_X123\_1234.1234 X'. A square QR code is located on the right side of the label.

OHA04563

### Dry Packing Process and Materials

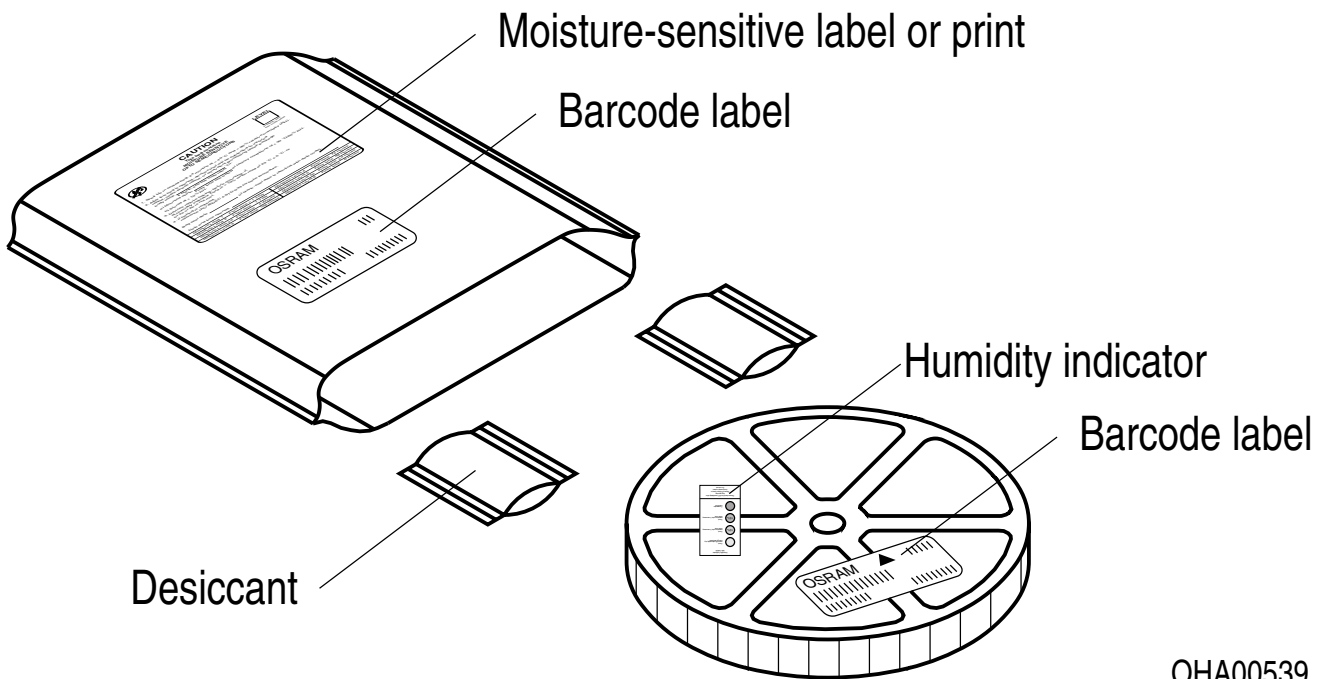

OHA00539

## Notes

The evaluation of eye safety occurs according to the standard IEC 62471:2006 (photo biological safety of lamps and lamp systems). Within the risk grouping system of this IEC standard, the device specified in this data sheet falls into the class **moderate risk (exposure time 0.25 s)**. Under real circumstances (for exposure time, conditions of the eye pupils, observation distance), it is assumed that no endangerment to the eye exists from these devices. As a matter of principle, however, it should be mentioned that intense light sources have a high secondary exposure potential due to their blinding effect. When looking at bright light sources (e.g. headlights), temporary reduction in visual acuity and afterimages can occur, leading to irritation, annoyance, visual impairment, and even accidents, depending on the situation.

Subcomponents of this device contain, in addition to other substances, metal filled materials including silver. Metal filled materials can be affected by environments that contain traces of aggressive substances. Therefore, we recommend that customers minimize device exposure to aggressive substances during storage, production, and use. Devices that showed visible discoloration when tested using the described tests above did show no performance deviations within failure limits during the stated test duration. Respective failure limits are described in the IEC60810.

This device is designed for specific/recommended applications only. Please consult OSRAM Opto Semiconductors Sales Staff in advance for detailed information on other non-recommended applications (e.g. automotive).

Change management for this component is aligned with the requirements of the lighting market.

For further application related information please visit [www.osram-os.com/appnotes](http://www.osram-os.com/appnotes)



## Disclaimer

### **Attention please!**

The information describes the type of component and shall not be considered as assured characteristics. Terms of delivery and rights to change design reserved. Due to technical requirements components may contain dangerous substances.

For information on the types in question please contact our Sales Organization.

If printed or downloaded, please find the latest version on the OSRAM OS website.

### **Packing**

Please use the recycling operators known to you. We can also help you – get in touch with your nearest sales office. By agreement we will take packing material back, if it is sorted. You must bear the costs of transport. For packing material that is returned to us unsorted or which we are not obliged to accept, we shall have to invoice you for any costs incurred.

### **Product and functional safety devices/applications or medical devices/applications**

OSRAM OS components are not developed, constructed or tested for the application as safety relevant component or for the application in medical devices.

OSRAM OS products are not qualified at module and system level for such application.

In case buyer – or customer supplied by buyer – considers using OSRAM OS components in product safety devices/applications or medical devices/applications, buyer and/or customer has to inform the local sales partner of OSRAM OS immediately and OSRAM OS and buyer and /or customer will analyze and coordinate the customer-specific request between OSRAM OS and buyer and/or customer.

## Glossary

- 1) **Wavelength:** The wavelength is measured at a current pulse of typically 10 ms, with a tolerance of  $\pm 0.5$  nm.
- 2) **Forward Voltage:** The Forward voltage is measured during a current pulse duration of typically 1 ms with a tolerance of  $\pm 0.05V$  .
- 3) **Brightness:** Brightness values are measured during a current pulse of typically 10 ms, with a tolerance of  $\pm 7\%$ .
- 4) **Typical Values:** Due to the special conditions of the manufacturing processes of semiconductor devices, the typical data or calculated correlations of technical parameters can only reflect statistical figures. These do not necessarily correspond to the actual parameters of each single product, which could differ from the typical data and calculated correlations or the typical characteristic line. If requested, e.g. because of technical improvements, these typ. data will be changed without any further notice.
- 5) **Characteristic curve:** In the range where the line of the graph is broken, you must expect higher differences between single devices within one packing unit.
- 6) **Tolerance of Measure:** Unless otherwise noted in drawing, tolerances are specified with  $\pm 0.1$  and dimensions are specified in mm.
- 7) **Tape and Reel:** All dimensions and tolerances are specified acc. IEC 60286-3 and specified in mm.

---

## Revision History

Version	Date	Change
1.0	2020-05-14	Initial Version
1.1	2020-06-15	Features Characteristics Brightness Groups Forward Voltage Groups Dimensional Drawing
1.1	2020-07-28	Features Characteristics Brightness Groups Forward Voltage Groups Dimensional Drawing
1.1	2020-09-15	Taping
1.2	2020-11-26	Reel Dimensions

Published by OSRAM Opto Semiconductors GmbH EU RoHS and China RoHS compliant product  
Leibnizstraße 4, D-93055 Regensburg  
www.osram-os.com © All Rights Reserved.



此产品符合欧盟 RoHS 指令的要求；  
按照中国的相关法规和标准，不含有毒有害物质或元素。