

THIS IS A C.A.D. GENERATED DRAWING
DO NOT MAKE MANUAL REVISIONS TO MASTER.

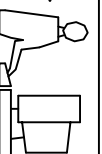

ISSUE NUMBER
ORIGINAL
①

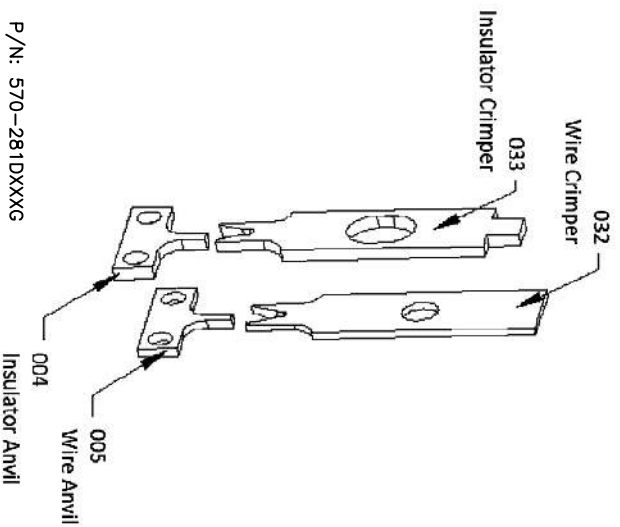
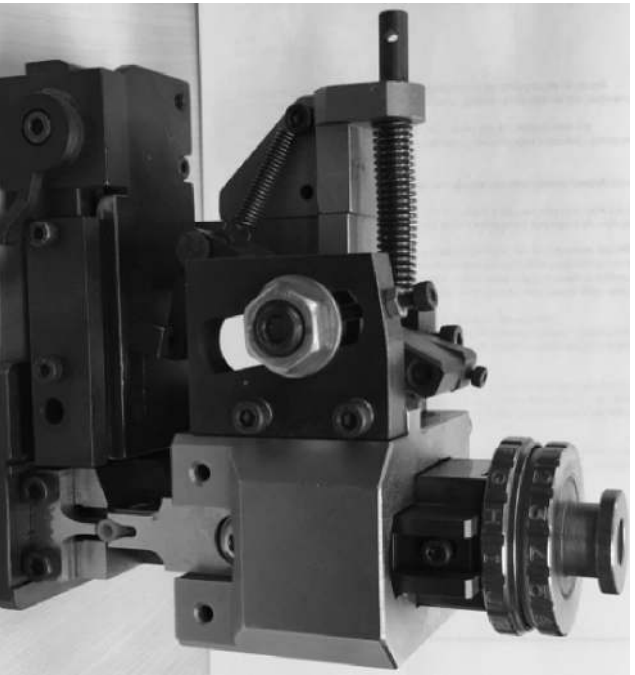

PRESS TYPE	G PRESS
STROKE LENGTH	40.00 MM
SHUT HEIGHT	135.79 MM
AWG	14-22

REPLACEMENT PUNCH & DIE PARTS			
INSULATOR ANVIL	WIRE ANVIL	WIRE CRIMPER	INSULATOR CRIMPER
570-281D004G	570-281D005G	570-281D032G	570-281D033G

NOTES:

- 1- THIS APPLICATOR IS DESIGNED TO BE USED ON A G CRIMPING MACHINE.
- 2- THIS APPLICATOR IS DESIGNED FOR CRIMPING EDAC CONTACT P/N 570-290-741 AND 570-291-741.
- 3- FOR THE DEFINITION OF STROKE LENGTH AND SHUT HEIGHT, APPLICATOR SETUP AND OPERATING INSTRUCTION, PLEASE REFER TO DOCUMENT "APPLICATOR INSTRUCTION MANUAL G PRESS".

G PRESS APPLICATOR FOR 570-29X-741

EDAC INC
TORONTO, ONTARIO
CANADA

THESE DRAWINGS AND SPECIFICATIONS ARE THE PROPERTY OF EDAC INC. AND SHALL NOT BE REPRODUCED, OR COPIED OR USED AS THE BASIS FOR THE MANUFACTURE OR SALE OF APPARATUS WITHOUT WRITTEN PERMISSION.

ACAD REFERENCE NO. 570-280-754G	DRAWN: K.L.	DATE: OCT.29/2020
	CHECKED: R.S.M.	DATE: OCT.29/2020
	SCALE: N.T.S.	SHEET 1 OF 1
DRAWING NUMBER 570-280-754G		ISSUE 1