



East Electronics



Product Specification

48273 Lakeview Blvd
Fremont, CA 94538, U.S.A
Tel: 510-413-0002
Fax: 510-413-0010
<http://www.east-elec.com>

Product Name:	High-Output Alarm Annunciator
Part Number:	EFM 290EDFL
Version:	1.0
Date:	2020-8-14
Note:	

East is an ISO 9001 , IATF16949 and ISO 14001 Certified Company

Revision History

Rev.	Description	Author/Date	Checked By	Approver
1.0	Released	汤礼东 2020-8-14	俞凯	王建成

1. Part Number EFM-290EDFL

2. Dimension Drawing (Unit: mm)

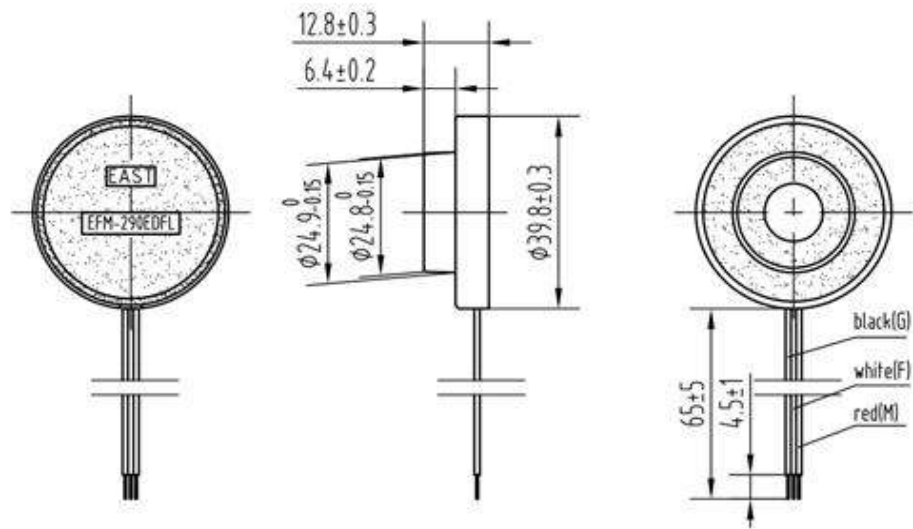

3. Specification

No.	Item	Specification
3-1	Min. Sound Pressure Level	85dB/7.5V _{DC} /300cm (Test Circuit 一)
		85dB/3V _{DC} /300cm (Test Circuit 二)
3-2	Rate Voltage	7.5V _{DC} (Test Circuit 一)
		3V _{DC} (Test Circuit 二)
3-3	Operating Voltage	5~12V _{DC} (Test Circuit 一)
		2~5V _{DC} (Test Circuit 二)
3-4	Max. Consumption	30mA/7.5V _{DC} (Test Circuit 一)
		40mA/3V _{DC} (Test Circuit 二)
3-5	Oscillating Frequency	3.2± 0.3kHz
3-6	Operating Temperature	-20~+70°C
3-7	Storage Temperature	-30~+85°C
3-8	Case Material /Color	HS2000X(PPO) /White
3-9	Weight	9.0g
3-10	Wire Standard	UL1095-28AWG

NOTE:

1.*This SPL level tested by the recommend cavity.

2.Test should be made under the conditions of room temperature ($20\pm 10^{\circ}\text{C}$), normal humidity ($60\pm 20\%$) and normal atmospheric pressure. In this case, however, that the judgment is questionable, the test conditions are to be changed to room temperature $20\pm 2^{\circ}\text{C}$, relative humidity 60~70% and normal atmospheric pressure.

4. Typical Frequency Response Curve

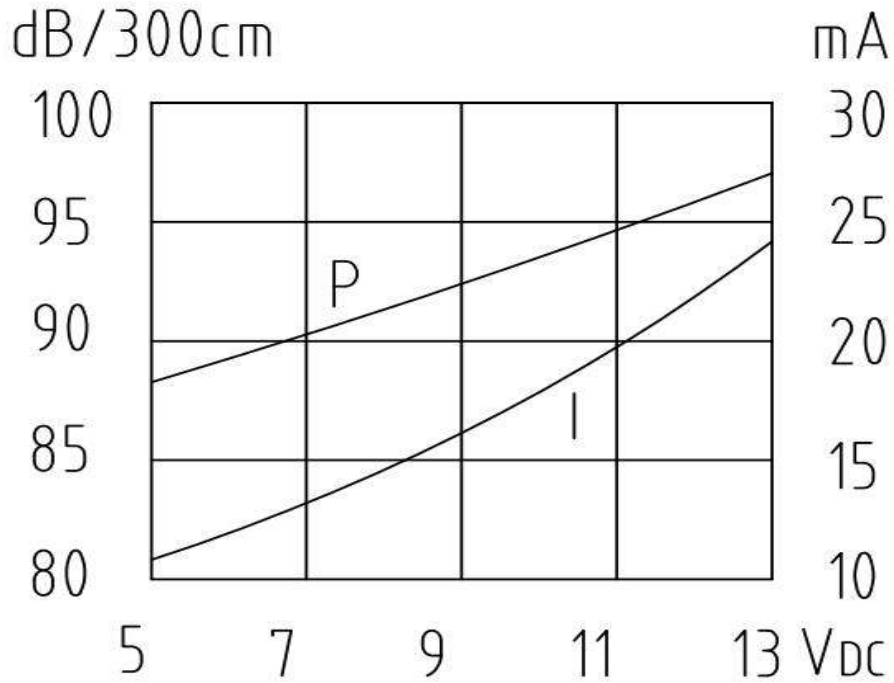

Note: Test Circuit 一 / Distance 300 cm

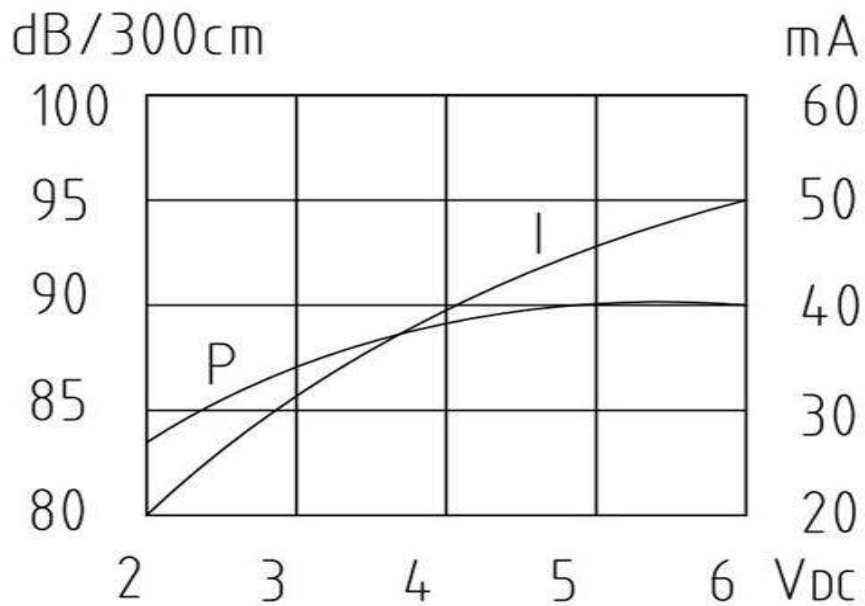

Note: Test Circuit 二 / Distance 300 cm

5. Electrical Testing Method

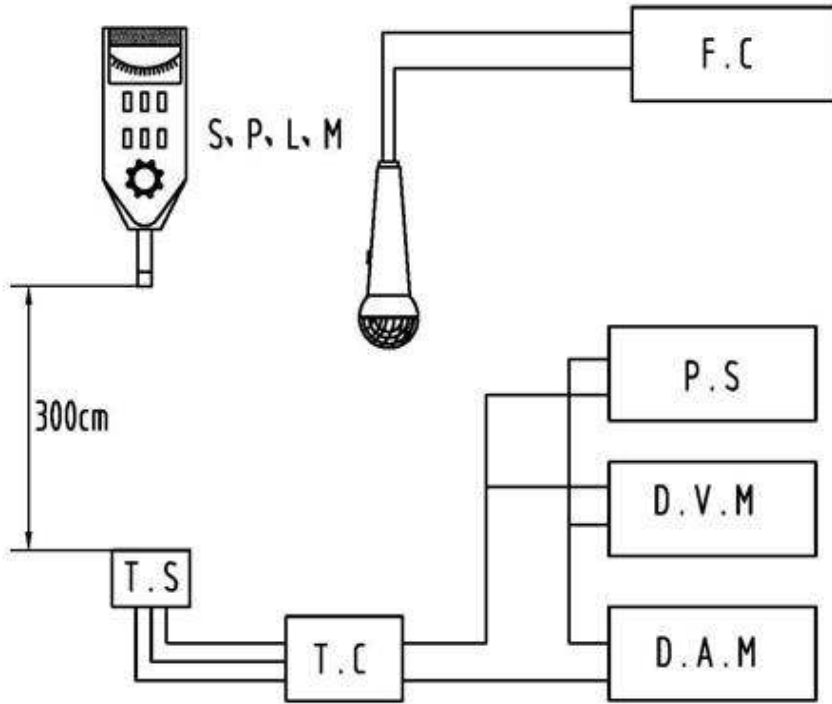

S.P.L.M	Sound Pressure Level Meter
T.S	Testing Sample
T.C	Test Circuit
F.C	Frequency Counter
P.S	Power Supply
D.V.M	DC Voltage Meter
D.A.M	DC Ampere Meter

Test Circuit —:

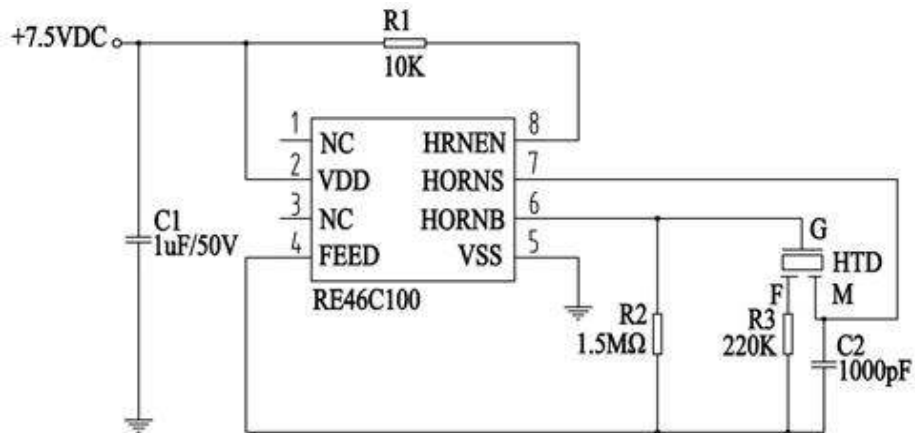

Test Circuit 二:

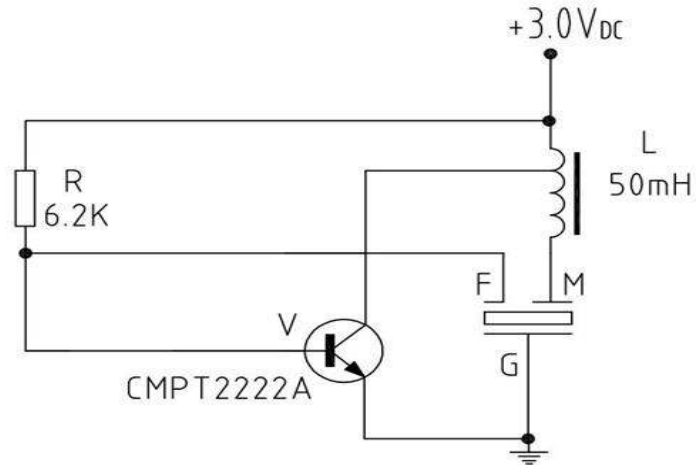

6. Packing Information

Packing: 1190 pcs per export carton

Carton Size: 47× 30.5× 23 cm

G. Weight: 14.0 kgs N. Weight: 11.4 kgs