

ISL9520EVAL1Z

Evaluation Board Setup Procedure

AN1826

Rev.0.00

February 22, 2013

The ISL9520 is a highly integrated Narrow VDC regulator/battery charger controller for Li-ion/Li-ion polymer batteries. It has an SMBus interface and provides gate drive to external switching N-channel FETs that control system voltage, charge current limit, and input current limit. The ISL9520EVAL1Z evaluation board includes a USB to SMBus interface to allow users to control the ISL9520 from a personal computer.

What's Inside

The ISL9520EVAL1Z Evaluation Board Kit contains the following materials:

- Qty (1) ISL9520EVAL1Z Evaluation Board
- Qty (1) USB cable

What's Needed

The following materials are recommended to perform testing (Figure 1):

- One adjustable 25V/6A power supply
- Two adjustable electronic loads with selectable constant current mode and constant voltage mode
- One volt meter
- One 500MHz four-channel oscilloscope with voltage and current probes
- A personal computer (PC) loaded with ISL9520 control software and drivers

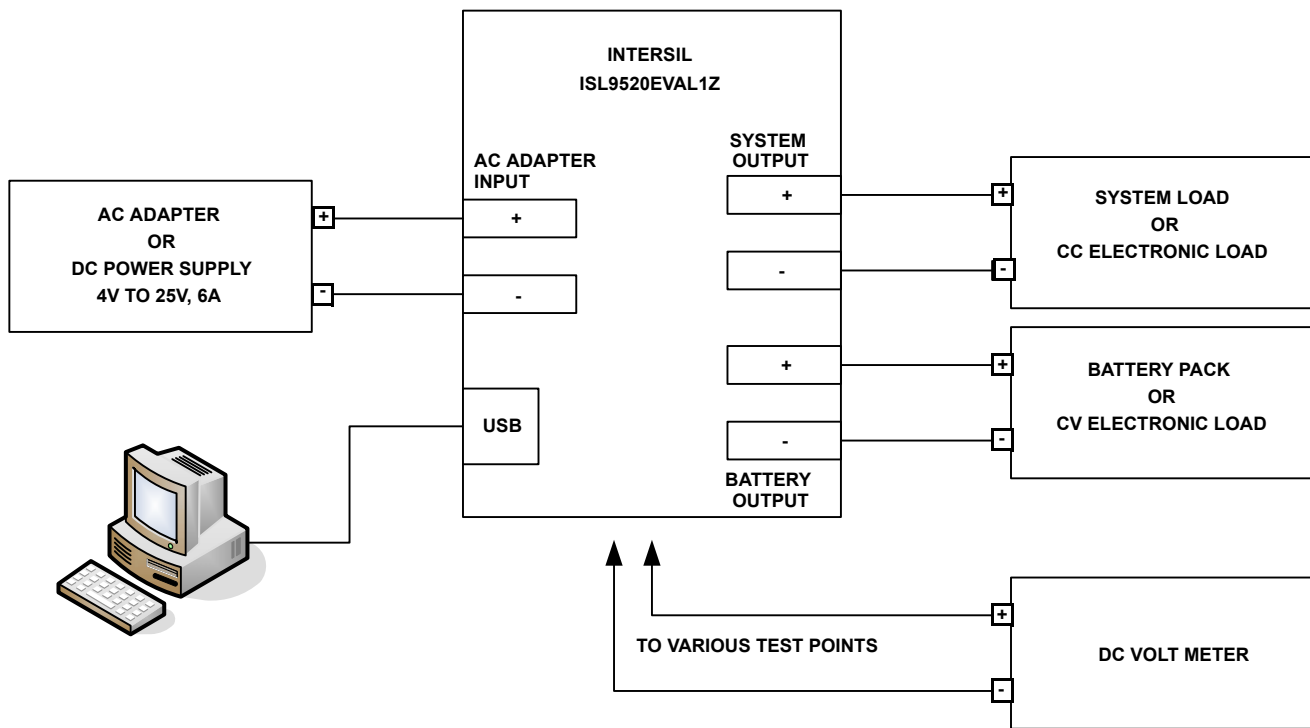

FIGURE 1. ISL9520EVAL1Z HARDWARE CONNECTION DIAGRAM

Install the Software

Download and install the ISL9520 control software by following the instructions provided in the “ISL9520 Software Installation Guide”. This document also contains troubleshooting instructions to be used in the rare event that the software does not install on the first attempt.

Run the ISL9520 Application

Plug the USB cable up, one end to the computer and the other end to the evaluation board. No other connections are required to read and write to the registers.

The ISL9520 evaluation software should be available in your computer’s **Start** → **All Programs** list. The “Intersil” folder will contain the program. Click the program name ISL9520 Control C1 to run the application.

Figure 2 shows the DAC Controls tab of the ISL9520 user interface. Initially, the software will indicate “FFFF” for the register values. Click the Read All icon to read the actual initial values in the registers.

Charge Current, Input Current, Max System Voltage, and Min System Voltage can be edited by clicking on the up/down arrows or by placing the cursor at the desired location and typing the correction. If the sense resistor shunts RS1 or RS2 have been changed on the board then the sense resistor values in the blue boxes should also be changed accordingly so that correct binary values are sent. The eggshell colored boxes are the digital values sent and read.

The white WRITE ALL 1/min box should be checked if a continuous test is desired, otherwise the SMBus Inactivity Time-out timer will shut down charging after 3 minutes.

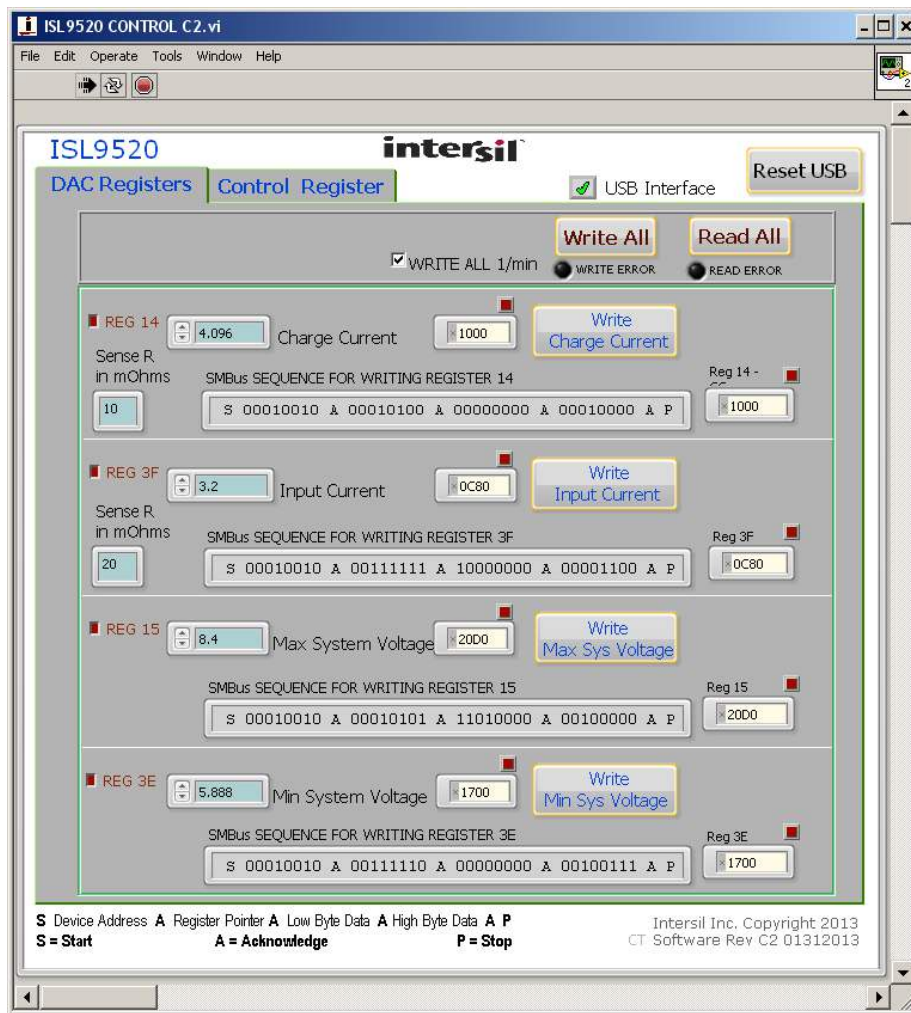

FIGURE 2. ISL9520 DAC CONTROLS TAB

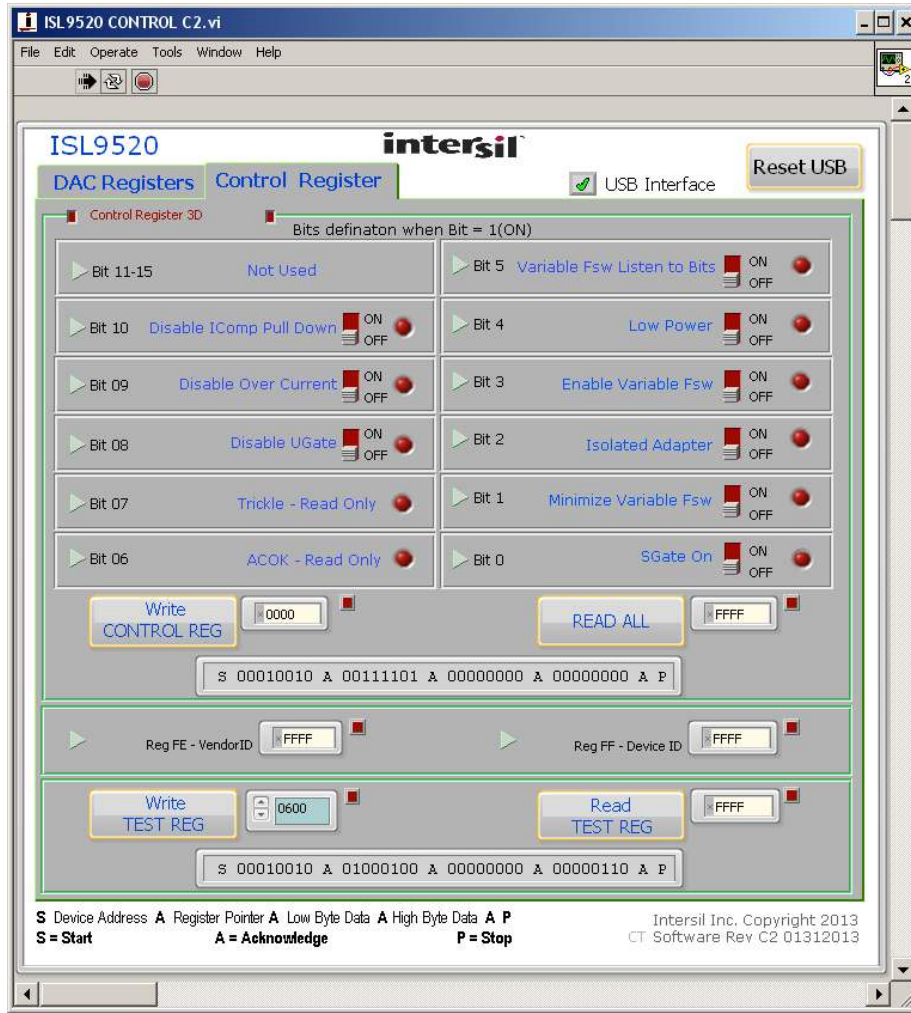

FIGURE 3. ISL9520 CONTROL REGISTER TAB

Figure 3 shows (ISL9520 Control Register tab) the control register 3D described in the data sheet and the bits that may be toggled by clicking on the individual bit switches. The configuration will be written when the Write CONTROL REG icon is clicked. The configuration is read when the READ ALL icon is clicked.

The Test Register should be written with “0600” to optimize the mode boundary transitions. To do this, place the cursor to the right of the first zero in the blue box, type a “6”, then hit the delete key once. Click on the Write test register icon, then click on the Read TEST REG icon to verify that the register has been updated.

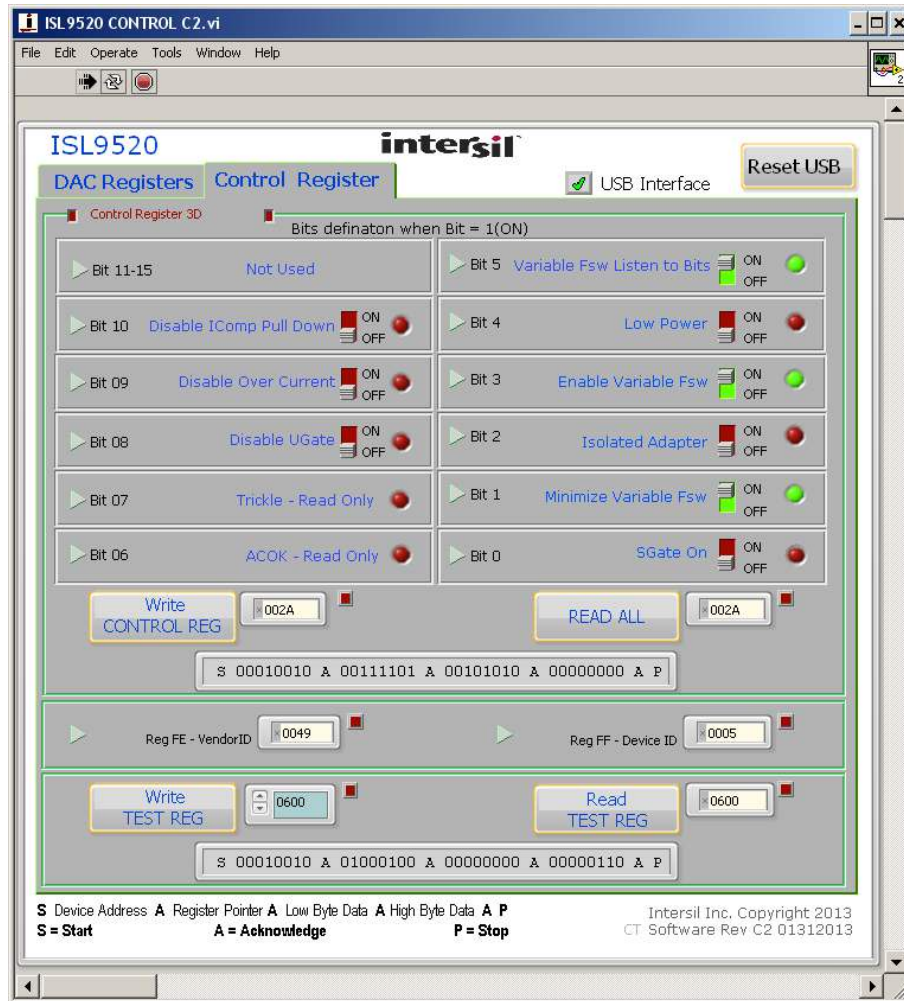

FIGURE 4. ISL9520 CONTROL REGISTER TAB AFTER EDITING TEST REGISTER

Figure 4 shows the updated Control Register tab. The VendorID (reg FE) and DeviceID (reg FF) should display 0049 and 0005 respectively.

If the power connections have not already been made, they can be made at this time. Figure 1 shows the required power connections.

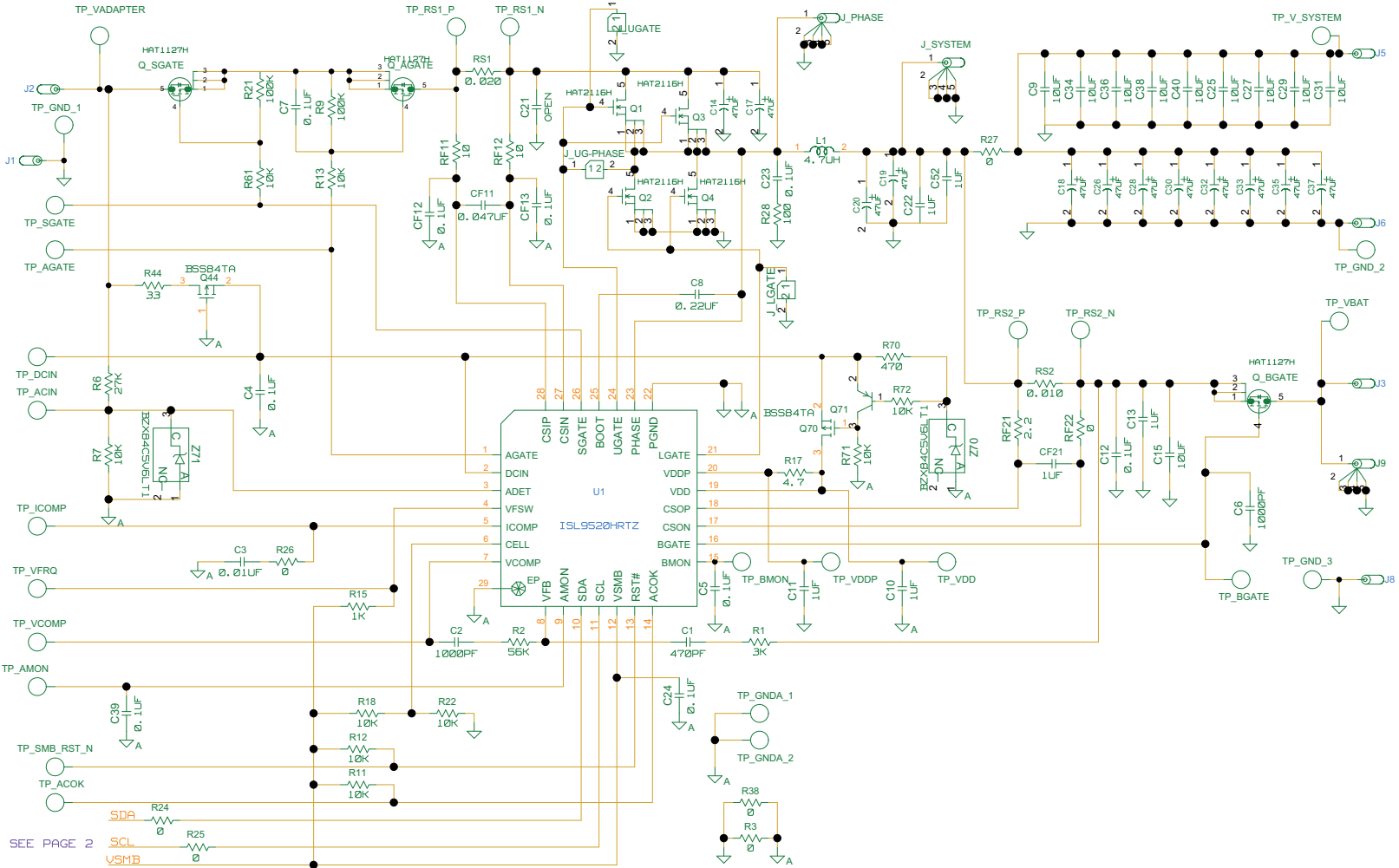

FIGURE 5. ISL9520EVAL1Z REV A SCHEMATIC

ISL9520EVAL1Z Schematics

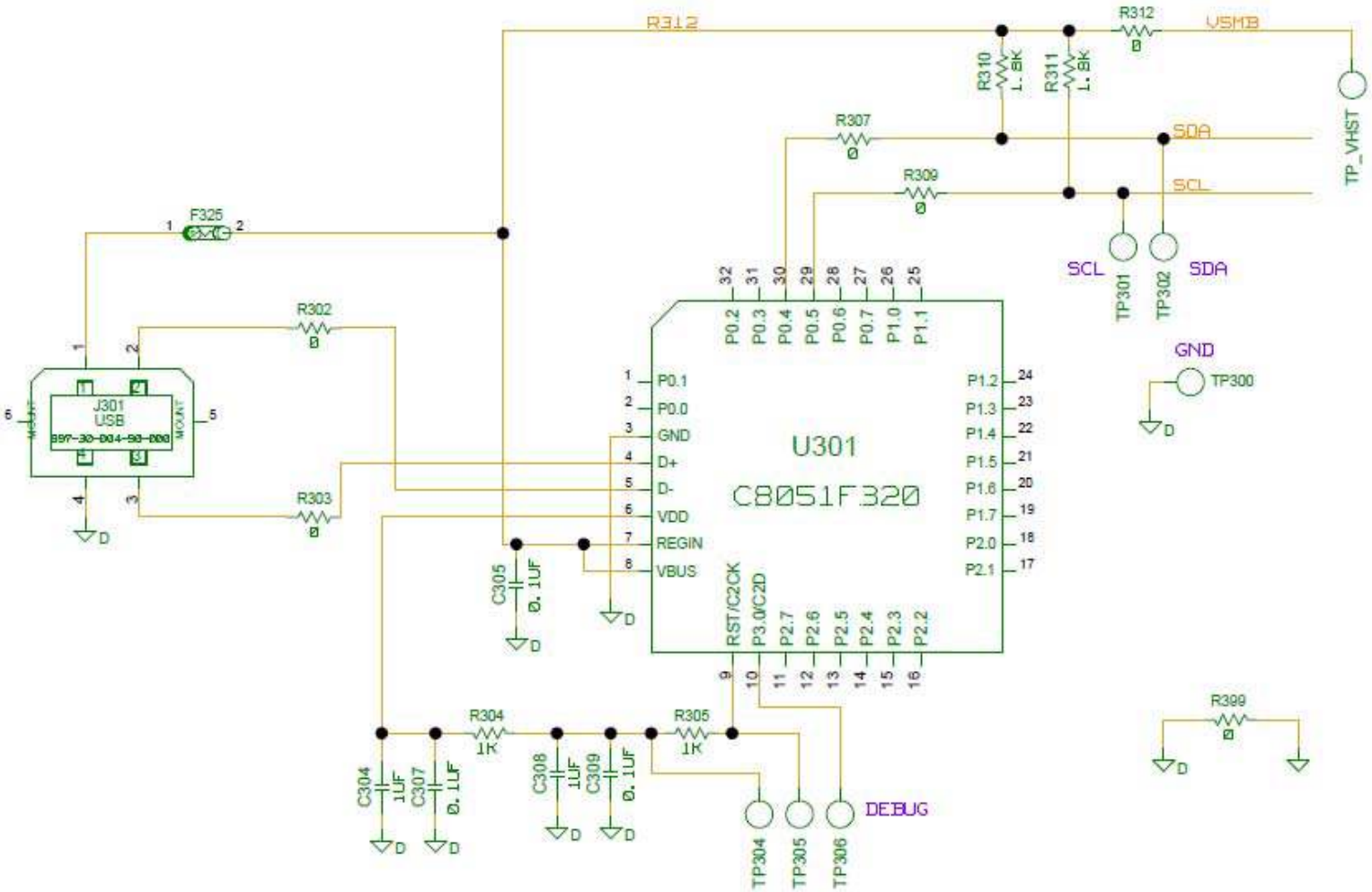

FIGURE 6. ISL9520 EVAL1Z REV A SCHEMATIC

ISL9520EVAL1Z Schematics (Continued)

TABLE 1. ISL9520EVAL1Z, REV A EVALUATION BOARD BILL OF MATERIALS

NO.	REFERENCE DESIGNATOR	QTY	DESCRIPTION	MANUFACTURER
1	C1	1	CAP, SMD, 0603, 470pF, 50V, 5%, X7R, ROHS	GENERIC
2	C2, C5, C6, C39	4	CAP, SMD, 0603, 1000pF, 50V, 5%, X7R, ROHS	GENERIC
3	C3	1	CAP, SMD, 0402, 0.068μF, 25V, 10%, X7R, ROHS	GENERIC
4	C10, C11, CF21, C304, C308	5	CAP, SMD, 0603, 1.0μF, 16V, 20%, X7R, ROHS	GENERIC
5	C13, C22, C52	3	CAP, SMD, 0805, 1.0μF, 25V, 10%, X5R, ROHS	GENERIC
6	C14, C17	2	CAP, SMD, 25TQC33MY, 33μF, 25V, 20%, ROHS	SANYO
7	C18, C19, C20, C26, C28, C30, C32, C33, C35, C37	10	CAP, SMD, 20TQC47MY, 47μF, 20V, 20%, ROHS	SANYO
8	C15	1	CAP, SMD, 1206, 10μF, 25V, 20%, X5R, ROHS	GENERIC
9	C4, C7, C12, C24, C39, CF12, CF13, C305, C307, C309	9	CAP, SMD, 0603, 0.1μF, 25V, 10%, X7R, ROHS	GENERIC
10	C9, C25, C27, C29, C31, C34, C36, C38, C40	9	CAP, SMD, 1812, 10μF, 25V, 20%, ROHS	
11	CF11	1	CAP, SMD, 0603, 0.047μF, 25V, 10%, X7R, ROHS	GENERIC
12	C8	1	CAP, SMD, 0603, 0.22μF, 25V, 20%, X7R, ROHS	GENERIC
13	F325	1	FUSE, SMD, MICROSMD050F	RAYCHEM-TYCO
14	J1, J6, J8	3	JACK, BANANA, BLACK, 164-6218	MOUSER
15	J2, J3, J5	3	JACK, BANANA, RED, 164-6219	MOUSER
16	JUSB	1	CONNECTOR, USB, MINI TYPE B	MIL-MAX
17	J9, J_PHASE, J_SYSTEM	3	TEST POINT, SCOPE PROBE, 131-5031-00	TEKTRONIX
18	L1	1	INDUCTOR, SMD, 4.7μH, 24A, IHLP5050CE-ER-4R7-M-01	VISHAY/DALE
19	Q_AGATE, Q_BGATE, Q_SGATE	3	MOSFET, P-CHANNEL, SMD, LFPK, 30V, 40A, HAT1127H	RENESAS
20	Q44	1	MOSFET, P-CHANNEL, SMD, SOT23, BSS84TA	FAIRCHILD
21	R1	1	RES, SMD, 0603, 3.01kΩ, 1/10W, 1%, TF, ROHS	GENERIC
22	R2	1	RES, SMD, 0603, 56.2kΩ, 1/10W, 1%, TF, ROHS	GENERIC
23	R3, R24, R25, RF22, R38, R302, R303, R307, R309, R312, R399	11	RES, SMD, 0603, 0Ω, 1/10W, TF, ROHS	GENERIC
24	RF11, RF12	2	RES, SMD, 0603, 10, 1/10W, 5%, TF, ROHS	GENERIC
25	R17	1	RES, SMD, 0603, 4.7Ω, 1/10W, 5%, TF, ROHS	GENERIC
26	R26		RES, SMD, 0603, 499Ω, 1/10W, 1%, TF, ROHS	
27	RF21	1	RES, SMD, 0603, 2.2Ω, 1/10W, 5%, TF, ROHS	GENERIC
28	R27	1	RES, SMD, 2010, 0Ω, 1/2W, 5%, TF, ROHS	GENERIC
29	R7, R9, R21	3	RES, SMD, 0603, 100kΩ, 1/10W, 1%, TF, ROHS	GENERIC
30	R15, R304, R305	3	RES, SMD, 0603, 1kΩ, 1/10W, 1%, TF, ROHS	GENERIC
31	R310, R311	2	RES, SMD, 0603, 1.8kΩ, 1/10W, 5%, TF, ROHS	GENERIC
32	R11, R12, R13, R61	4	RES, SMD, 0603, 10.0kΩ, 1/10W, 1%, TF, ROHS	GENERIC
33	R44	1	RES, SMD, 0603, 33.2Ω, 1/10W, 1%, TF, ROHS	GENERIC
34	R6	1	RES, SMD, 0603, 402kΩ, 1/10W, 1%, TF, ROHS	GENERIC
35	RS1	1	RES, SMD, 2010, 0.02Ω, 1W, 1%, LRC-LRF2010-01-R020-F	IRC
36	RS2	1	RES, SMD, 2010, 0.01Ω, 1W, 1%, LRC-LRF2010-01-R010-F	IRC

TABLE 1. ISL9520EVAL1Z, REV A EVALUATION BOARD BILL OF MATERIALS (Continued)

NO.	REFERENCE DESIGNATOR	QTY	DESCRIPTION	MANUFACTURER
37	TP_ACIN, TP_ACOK, TP_AMON, TP_VFRQ, TP_ICOMP, TP_VCOMP, TP_SMB_RST_N	7	TEST POINT, 0.063", COMPACT YELLOW, CTP5009	KEYSTONE
38	TP_DCIN, TP_AGATE, TP_BGATE, TP_GND_1, TP_GND2, TP_GND_3, TP_RS1_N, TP_RS2_N, TP_SGATE, TP_GNDA_1, TP_GNDA_2	11	TEST POINT, 0.063", COMPACT BLACK, CTP5006	KEYSTONE
39	TP_VDD, TP_VBAT, TP_VDDP, TP_VADAPTER, TP_V_SYSTEM	5	TEST POINT, 0.063", COMPACT RED, CTP5005	KEYSTONE
40	TP304, TP305, TP306, TP_SCL, TP_SDA, TP_VHST, TP_GND_D, TP_RS1_P, TP_RS2_P	9	TEST POINT, 0.063", COMPACT WHITE, CTP5007	KEYSTONE
41	U1	1	IC, BATTERY CHARGER, ISL9520, QFN50_5X7B_EP	INTERSIL
42	U301	1	IC, MICROCONTROLLER, C8051F320, 32LQFP_80	SILICON LABS

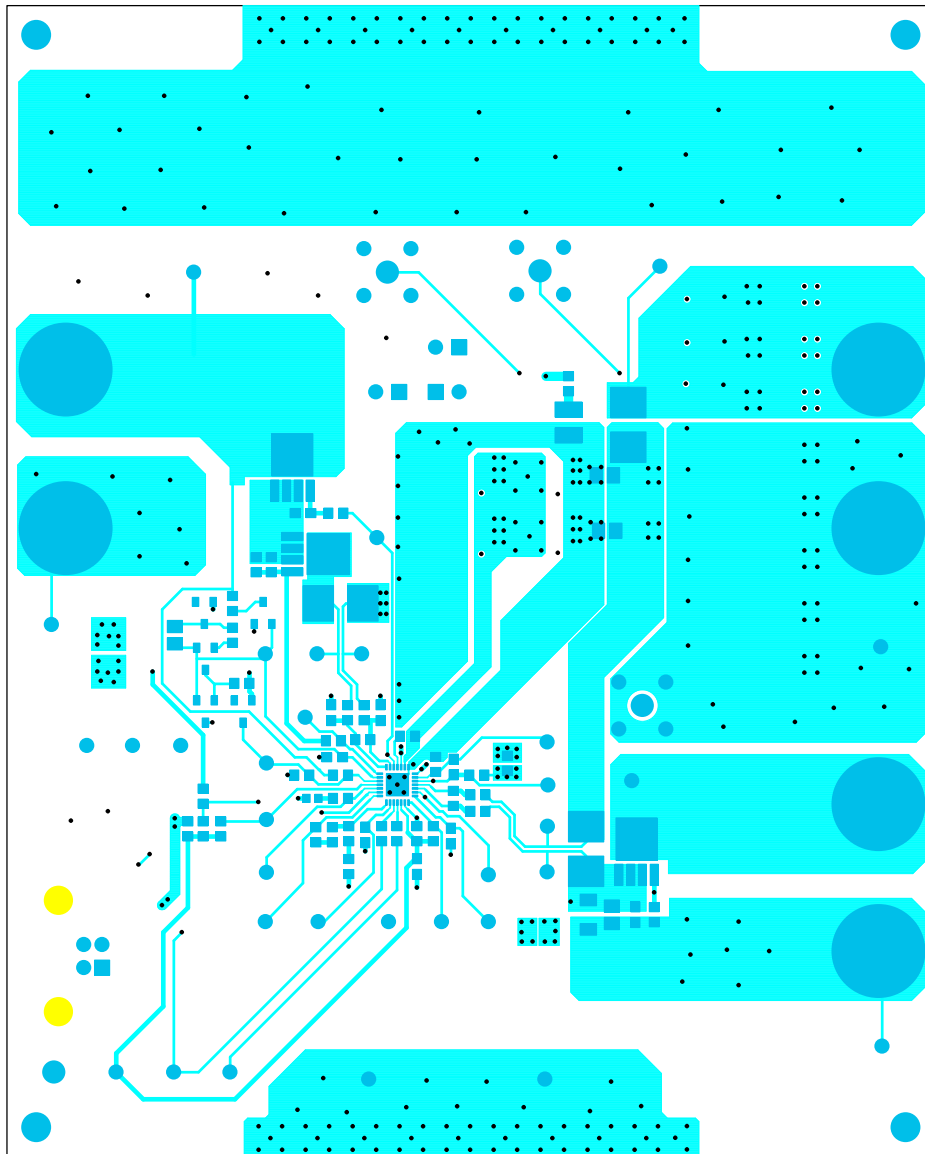

FIGURE 9. TOP LAYER COPPER

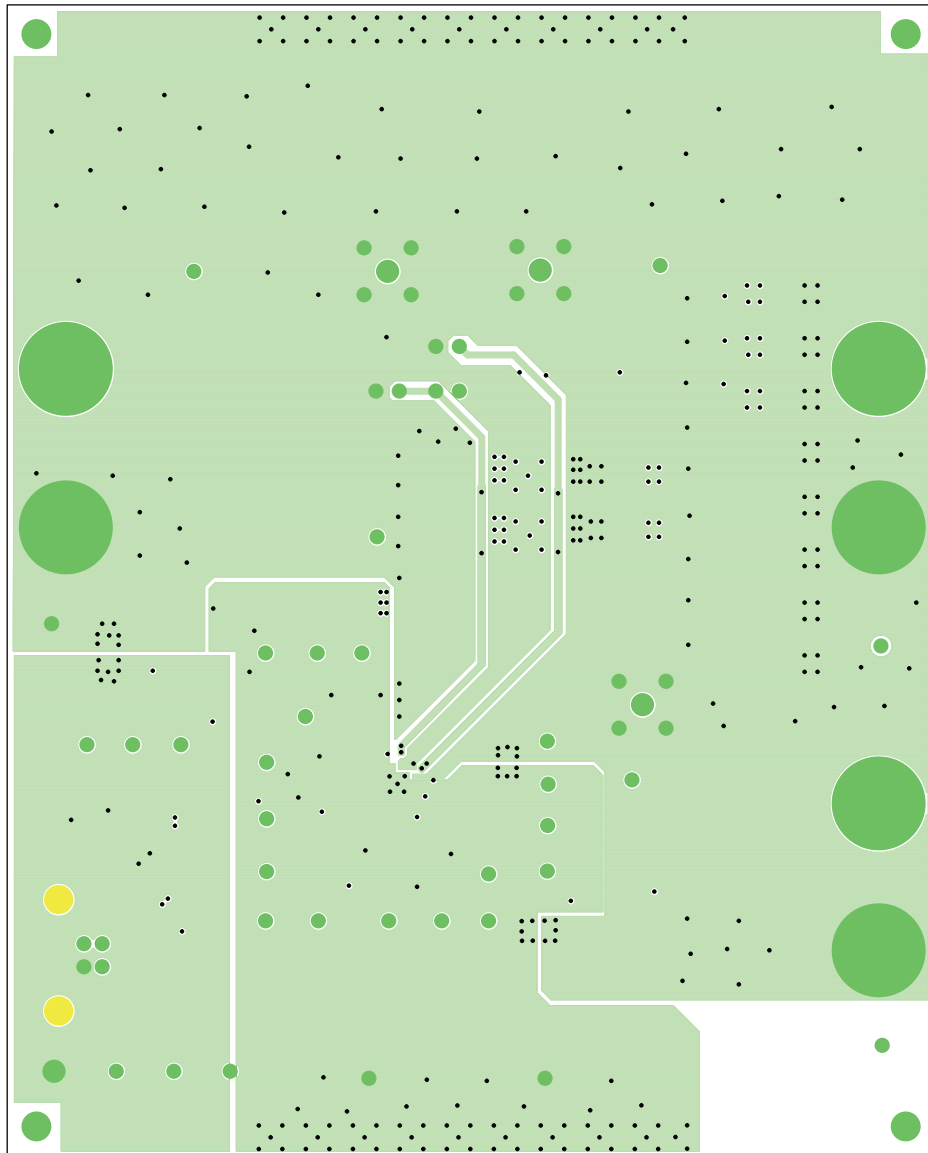

FIGURE 10. LAYER 2 COPPER

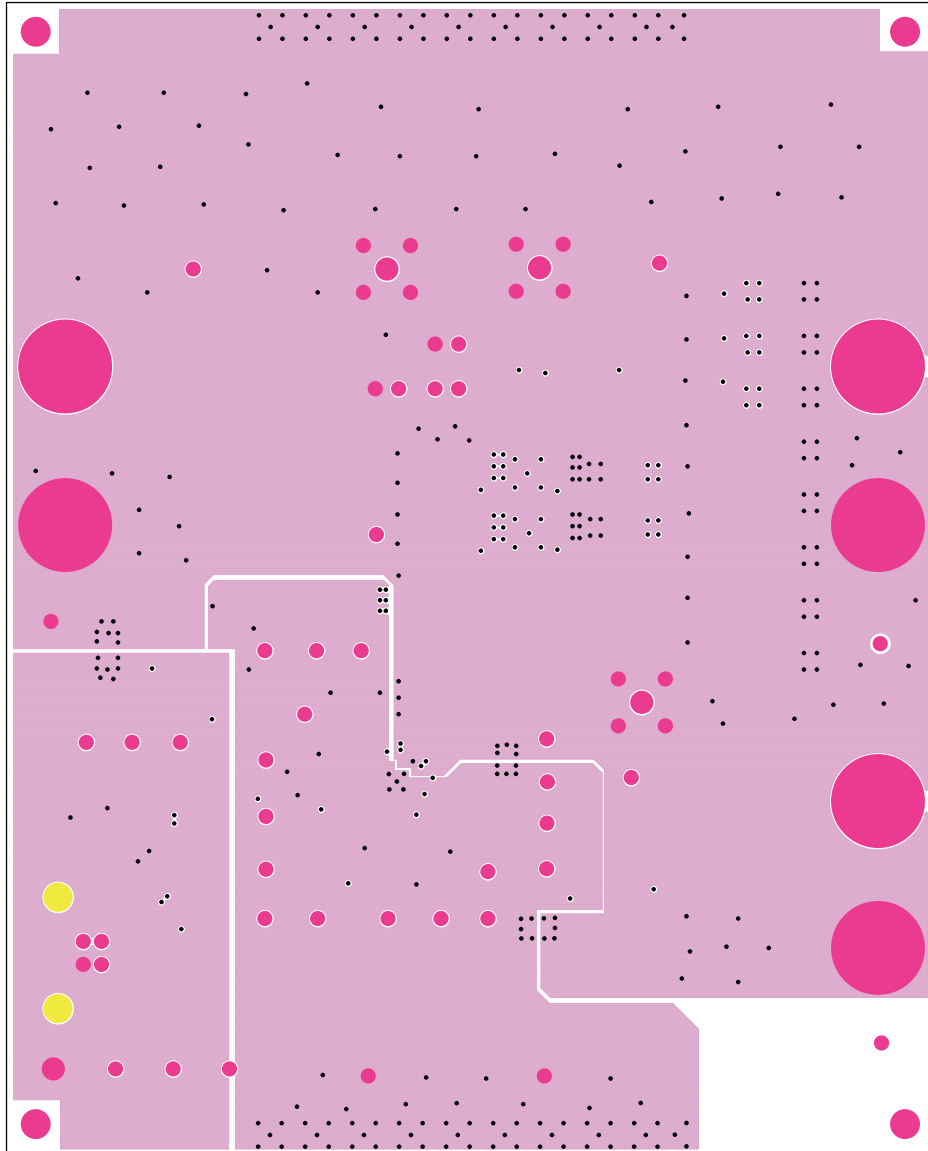

FIGURE 11. LAYER 3 COPPER

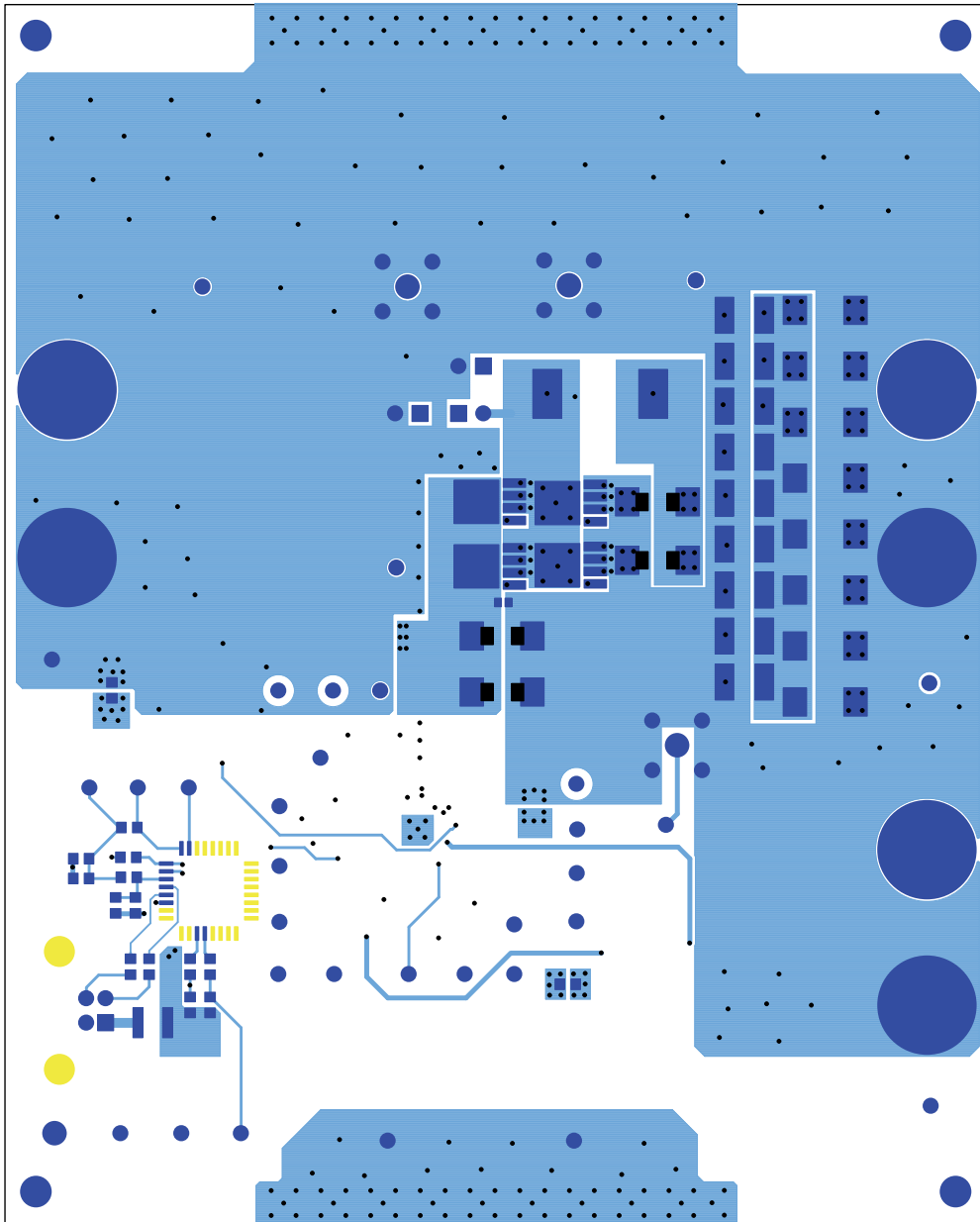

FIGURE 12. BOTTOM LAYER COPPER

Notice

1. Descriptions of circuits, software and other related information in this document are provided only to illustrate the operation of semiconductor products and application examples. You are fully responsible for the incorporation or any other use of the circuits, software, and information in the design of your product or system. Renesas Electronics disclaims any and all liability for any losses and damages incurred by you or third parties arising from the use of these circuits, software, or information.
2. Renesas Electronics hereby expressly disclaims any warranties against and liability for infringement or any other claims involving patents, copyrights, or other intellectual property rights of third parties, by or arising from the use of Renesas Electronics products or technical information described in this document, including but not limited to, the product data, drawings, charts, programs, algorithms, and application examples.
3. No license, express, implied or otherwise, is granted hereby under any patents, copyrights or other intellectual property rights of Renesas Electronics or others.
4. You shall not alter, modify, copy, or reverse engineer any Renesas Electronics product, whether in whole or in part. Renesas Electronics disclaims any and all liability for any losses or damages incurred by you or third parties arising from such alteration, modification, copying or reverse engineering.
5. Renesas Electronics products are classified according to the following two quality grades: "Standard" and "High Quality". The intended applications for each Renesas Electronics product depends on the product's quality grade, as indicated below.
"Standard": Computers; office equipment; communications equipment; test and measurement equipment; audio and visual equipment; home electronic appliances; machine tools; personal electronic equipment; industrial robots; etc.
"High Quality": Transportation equipment (automobiles, trains, ships, etc.); traffic control (traffic lights); large-scale communication equipment; key financial terminal systems; safety control equipment; etc.
Unless expressly designated as a high reliability product or a product for harsh environments in a Renesas Electronics data sheet or other Renesas Electronics document, Renesas Electronics products are not intended or authorized for use in products or systems that may pose a direct threat to human life or bodily injury (artificial life support devices or systems; surgical implantations; etc.), or may cause serious property damage (space system; undersea repeaters; nuclear power control systems; aircraft control systems; key plant systems; military equipment; etc.). Renesas Electronics disclaims any and all liability for any damages or losses incurred by you or any third parties arising from the use of any Renesas Electronics product that is inconsistent with any Renesas Electronics data sheet, user's manual or other Renesas Electronics document.
6. When using Renesas Electronics products, refer to the latest product information (data sheets, user's manuals, application notes, "General Notes for Handling and Using Semiconductor Devices" in the reliability handbook, etc.), and ensure that usage conditions are within the ranges specified by Renesas Electronics with respect to maximum ratings, operating power supply voltage range, heat dissipation characteristics, installation, etc. Renesas Electronics disclaims any and all liability for any malfunctions, failure or accident arising out of the use of Renesas Electronics products outside of such specified ranges.
7. Although Renesas Electronics endeavors to improve the quality and reliability of Renesas Electronics products, semiconductor products have specific characteristics, such as the occurrence of failure at a certain rate and malfunctions under certain use conditions. Unless designated as a high reliability product or a product for harsh environments in a Renesas Electronics data sheet or other Renesas Electronics document, Renesas Electronics products are not subject to radiation resistance design. You are responsible for implementing safety measures to guard against the possibility of bodily injury, injury or damage caused by fire, and/or danger to the public in the event of a failure or malfunction of Renesas Electronics products, such as safety design for hardware and software, including but not limited to redundancy, fire control and malfunction prevention, appropriate treatment for aging degradation or any other appropriate measures. Because the evaluation of microcomputer software alone is very difficult and impractical, you are responsible for evaluating the safety of the final products or systems manufactured by you.
8. Please contact a Renesas Electronics sales office for details as to environmental matters such as the environmental compatibility of each Renesas Electronics product. You are responsible for carefully and sufficiently investigating applicable laws and regulations that regulate the inclusion or use of controlled substances, including without limitation, the EU RoHS Directive, and using Renesas Electronics products in compliance with all these applicable laws and regulations. Renesas Electronics disclaims any and all liability for damages or losses occurring as a result of your noncompliance with applicable laws and regulations.
9. Renesas Electronics products and technologies shall not be used for or incorporated into any products or systems whose manufacture, use, or sale is prohibited under any applicable domestic or foreign laws or regulations. You shall comply with any applicable export control laws and regulations promulgated and administered by the governments of any countries asserting jurisdiction over the parties or transactions.
10. It is the responsibility of the buyer or distributor of Renesas Electronics products, or any other party who distributes, disposes of, or otherwise sells or transfers the product to a third party, to notify such third party in advance of the contents and conditions set forth in this document.
11. This document shall not be reprinted, reproduced or duplicated in any form, in whole or in part, without prior written consent of Renesas Electronics.
12. Please contact a Renesas Electronics sales office if you have any questions regarding the information contained in this document or Renesas Electronics products.
(Note 1) "Renesas Electronics" as used in this document means Renesas Electronics Corporation and also includes its directly or indirectly controlled subsidiaries.
(Note 2) "Renesas Electronics product(s)" means any product developed or manufactured by or for Renesas Electronics.

(Rev.4.0-1 November 2017)



SALES OFFICES

Renesas Electronics Corporation

<http://www.renesas.com>

Refer to "<http://www.renesas.com/>" for the latest and detailed information.

Renesas Electronics America Inc.
1001 Murphy Ranch Road, Milpitas, CA 95035, U.S.A.
Tel: +1-408-432-8888, Fax: +1-408-434-5351

Renesas Electronics Canada Limited
9251 Yonge Street, Suite 8309 Richmond Hill, Ontario Canada L4C 9T3
Tel: +1-905-237-2004

Renesas Electronics Europe Limited
Dukes Meadow, Millboard Road, Bourne End, Buckinghamshire, SL8 5FH, U.K
Tel: +44-1628-651-700, Fax: +44-1628-651-804

Renesas Electronics Europe GmbH
Arcadiastrasse 10, 40472 Düsseldorf, Germany
Tel: +49-211-6503-0, Fax: +49-211-6503-1327

Renesas Electronics (China) Co., Ltd.
Room 1709 Quantum Plaza, No.27 ZhichunLu, Haidian District, Beijing, 100191 P. R. China
Tel: +86-10-8235-1155, Fax: +86-10-8235-7679

Renesas Electronics (Shanghai) Co., Ltd.
Unit 301, Tower A, Central Towers, 555 Langao Road, Putuo District, Shanghai, 200333 P. R. China
Tel: +86-21-2226-0888, Fax: +86-21-2226-0999

Renesas Electronics Hong Kong Limited
Unit 1601-1611, 16/F., Tower 2, Grand Century Place, 193 Prince Edward Road West, Mongkok, Kowloon, Hong Kong
Tel: +852-2265-6688, Fax: +852-2886-9022

Renesas Electronics Taiwan Co., Ltd.
13F, No. 363, Fu Shing North Road, Taipei 10543, Taiwan
Tel: +886-2-8175-9600, Fax: +886-2-8175-9670

Renesas Electronics Singapore Pte. Ltd.
80 Bendemeer Road, Unit #06-02 Hyflux Innovation Centre, Singapore 339949
Tel: +65-6213-0200, Fax: +65-6213-0300

Renesas Electronics Malaysia Sdn.Bhd.
Unit 1207, Block B, Menara Amcorp, Amcorp Trade Centre, No. 18, Jln Persiaran Barat, 46050 Petaling Jaya, Selangor Darul Ehsan, Malaysia
Tel: +60-3-7955-9390, Fax: +60-3-7955-9510

Renesas Electronics India Pvt. Ltd.
No.777C, 100 Feet Road, HAL 2nd Stage, Indiranagar, Bangalore 560 038, India
Tel: +91-80-67208700, Fax: +91-80-67208777

Renesas Electronics Korea Co., Ltd.
17F, KAMCO Yangjae Tower, 262, Gangnam-daero, Gangnam-gu, Seoul, 06265 Korea
Tel: +82-2-558-3737, Fax: +82-2-558-5338