

# 3M™ SlimLine Twin Axial Cable Assembly (SFF-8654) for SAS and PCIe applications

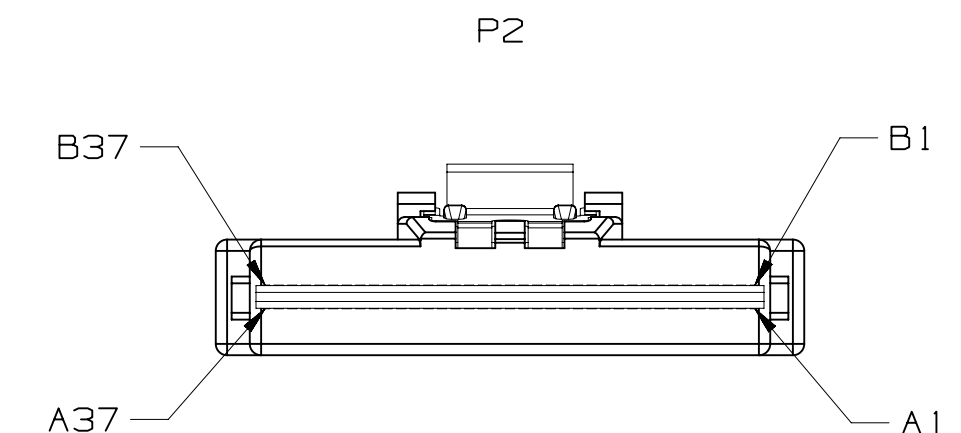
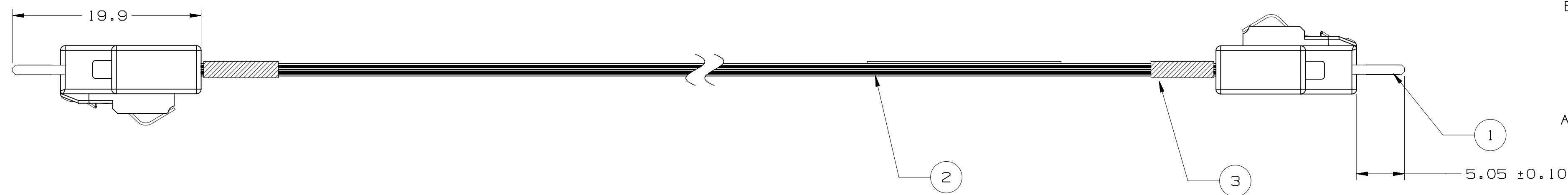
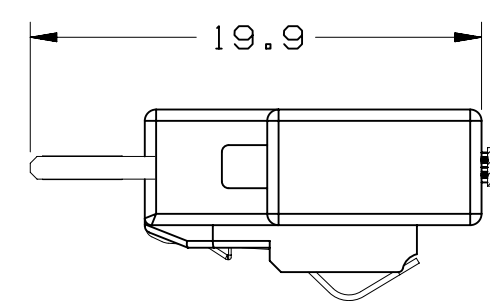
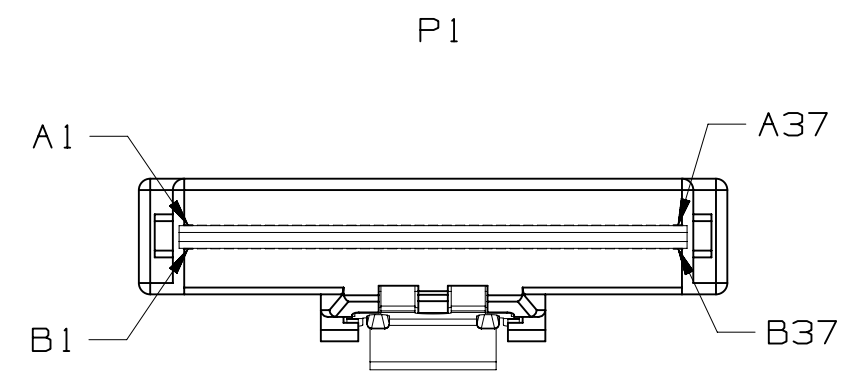
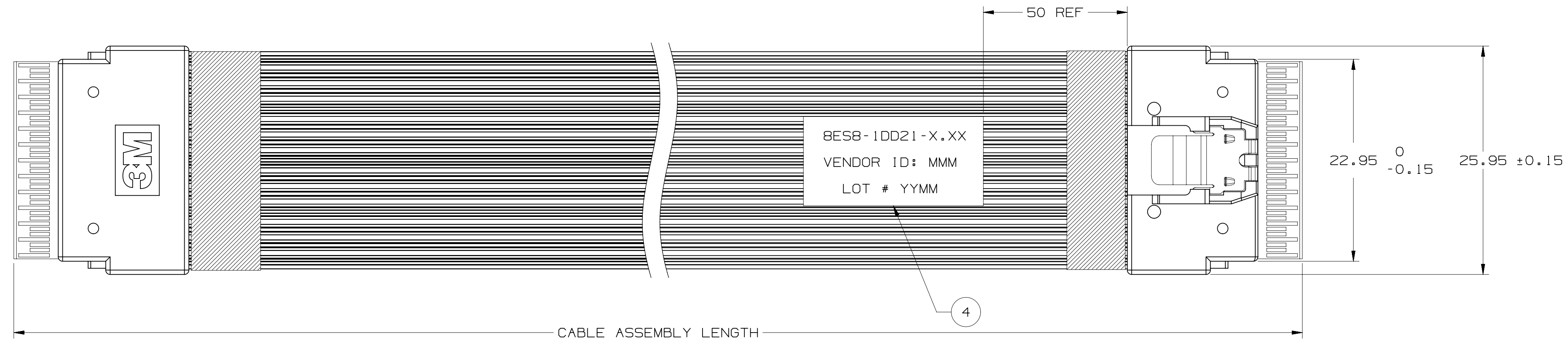

## NOTES:

- REGULATORY INFORMATION: VISIT [3M.com/regs](http://3M.com/regs) OR CONTACT YOUR 3M REPRESENTATIVE TO FIND THE RoHS COMPLIANCE STATUS OF THE 3M PART YOU ARE INTERESTED IN.
- PADDLECARD PLATING: 30μ" MIN. GOLD PLATING  
50μ" MIN. NICKEL UNDERPLATING.  
P/N: 78-9102-4549-3
- SLIMLINE CABLE PLUG DIMENSIONS ARE DESIGNED TO SFF-8654.
- UNLESS OTHERWISE NOTED, REFERENCES TO INDUSTRY SPECIFICATIONS ARE INTENDED TO INDICATE SUBSTANTIAL COMPLIANCE TO THE MATERIAL ELEMENTS OF THE SPECIFICATION. SUCH REFERENCE SHOULD NOT BE CONSTRUED AS A GUARANTEE OF COMPLIANCE TO ALL REQUIREMENTS IN A GIVEN SPECIFICATION.
- CLOTH TAPE WRAPPED AROUND CABLE RIBBONS AT BACK OF EACH CONNECTOR. ALSO, UP TO TWO ADDITIONAL TAPE PIECES WILL BE WRAPPED AROUND THE TWO CABLE RIBBONS SPACED EQUIDISTANT FROM THE CONNECTOR ENDS AND EACH OTHER, DEPENDING ON ASS'Y LENGTH (L):  
L <= 0.2M: NO ADDITIONAL TAPE  
0.2M < L <= 0.6M: 1 TAPE WRAP  
0.6M < L <= 1.0M: 2 TAPE WRAP
- PRODUCT SPECIFICATION: PS-240.
- CABLE ASSEMBLY MEETS SAS 3.0 SDD21 INSERTION LOSS SPECIFICATIONS UP TO 900mm LENGTH.
- TWO RIBBONS OF 3M™ RIBBON TWIN AXIAL CABLE.  
SL8802/24-BTMN5-00  
85 OHM, 31AWG, 12PR, HB
- THIS CABLE CONSTRUCTION HAS A THIN ALUMINUM LAYER AT EACH EDGE. USER SHOULD EVALUATE ITS USE IN THEIR APPLICATION AND, IF NECESSARY, INSULATING TAPE MAY BE APPLIED TO COVER THE ALUMINUM LAYER, AS USER DEEMS APPROPRIATE.
- LENGTH TOLERANCE:  
±6 MM FOR LENGTHS 0.125 TO 0.4 METERS,  
±10 MM FOR LENGTHS 0.4 TO 1.0 METERS.

3M PART NUMBER : 8ES8-1DD2X-X.XX

- 1 - ST-ST Plug Assembly.
- 2 - RA-ST Plug Assembly.
- 3 - RA-RA Plug Assembly.

LENGTH IN METERS 0.125 TO 1.00.

NOTE: ALL GND SIGNALS ARE TIED TOGETHER IN THE PADDLECARDS AT EACH END OF ASSEMBLY (A1, A4, A7, A13, A16, A19, A22, A25, A31, A34, A37, B1, B4, B7, B10, B13, B16, B19, B22, B25, B28, B31, B34, B37)

## PINOUT

P1		P2	P1		P2
A1	GND	B1	B1	GND	A1
A2	RX0+	B2	B2	TX0+	A2
A3	RX0-	B3	B3	TX0-	A3
A4	GND	B4	B4	GND	A4
A5	RX1+	B5	B5	TX1+	A5
A6	RX1-	B6	B6	TX1-	A6
A7	GND	B7	B7	GND	A7
A8	SB+	B8	B8	SB+	A8
A9	SB-	B9	B9	SB-	A9
A10	GND	B10	B10	GND	A10
A11	SB+	B11	B11	SB+	A11
A12	SB-	B12	B12	SB-	A12
A13	GND	B13	B13	GND	A13
A14	RX2+	B14	B14	TX2+	A14
A15	RX2-	B15	B15	TX2-	A15
A16	GND	B16	B16	GND	A16
A17	RX3+	B17	B17	TX3+	A17
A18	RX3-	B18	B18	TX3-	A18
A19	GND	B19	B19	GND	A19
A20	RX4+	B20	B20	TX4+	A20
A21	RX4-	B21	B21	TX4-	A21
A22	GND	B22	B22	GND	A22
A23	RX5+	B23	B23	TX5+	A23
A24	RX5-	B24	B24	TX5-	A24
A25	GND	B25	B25	GND	A25
A26	SB+	B26	B26	SB+	A26
A27	SB-	B27	B27	SB-	A27
A28	GND	B28	B28	GND	A28
A29	SB+	B29	B29	SB+	A29
A30	SB-	B30	B30	SB-	A30
A31	GND	B31	B31	GND	A31
A32	RX6+	B32	B32	TX6+	A32
A33	RX6-	B33	B33	TX6-	A33
A34	GND	B34	B34	GND	A34
A35	RX7+	B35	B35	TX7+	A35
A36	RX7-	B36	B36	TX7-	A36
A37	GND	B37	B37	GND	A37

8ES8-1DD2X-X.XX  
VENDOR ID: MMM  
LOT # YYMM

LABEL INFORMATION

ITEM	SPECIFICATION	QUANTITY
4	LABEL , 40X30MM	1X
3	ACETATE TAPE	AS REQUIRED
2	TWIN AX CABLE , REFER TO NOTES	AS PER LENGTH
1	SLIMLINE PLUG STRAIGHT OR RIGHT ANGLE	2X

REV	ECO	ISSUE DATE AND DESCRIPTION	DRFT	CHKD
B	B1149	JAN 14, 2019 CHANGE MIN. LENGTH	VT	VT
A	73021	MAR 27, 2017	RAO	RAO

DESIGN REFERENCE	NEXT ASSEMBLY
ADDRESS CODES: US882 US830a	

DRW	DATE	APPV	DATE
Rao Vittapalli	MAR 27, 2017	Liu JG	MAR 27, 2017
Rao Vittapalli	MAR 27, 2017	Saujit Bandhu	MAR 27, 2017

TOLERANCES EXCEPT AS NOTED
INCHES
0 ± .01
.01 ± .005
.005 ± .0005
.0005 ± .0001
MILLIMETERS
0 ± .1
.1 ± .05
.05 ± .005
.005 ± .0005

INTERPRET PER ASME Y14.5 - 2009
125
ALL SURFACES
MARKED ONLY

TITLE
CUSTOMER DRAWING SLIMLINE 85 OHM X8 31AWG CABLE ASSY

CAGE NUMBER	SIZE	DRAWING NO.	REV.
D		78-5100-2675-6	B

MODEL	DET	YES	NO	SHT	OF
				1	2

78-5100-2675-6  
DRAWING NUMBER

B

A

3M™ SlimLine Twin Axial Cable Assembly (SFF-8654) for SAS and PCIe applications

RA-ST Assembly.

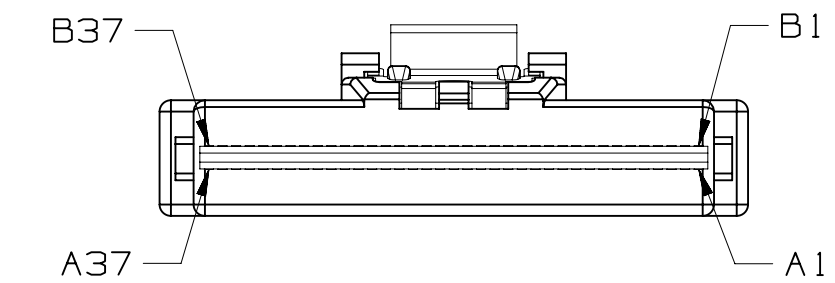
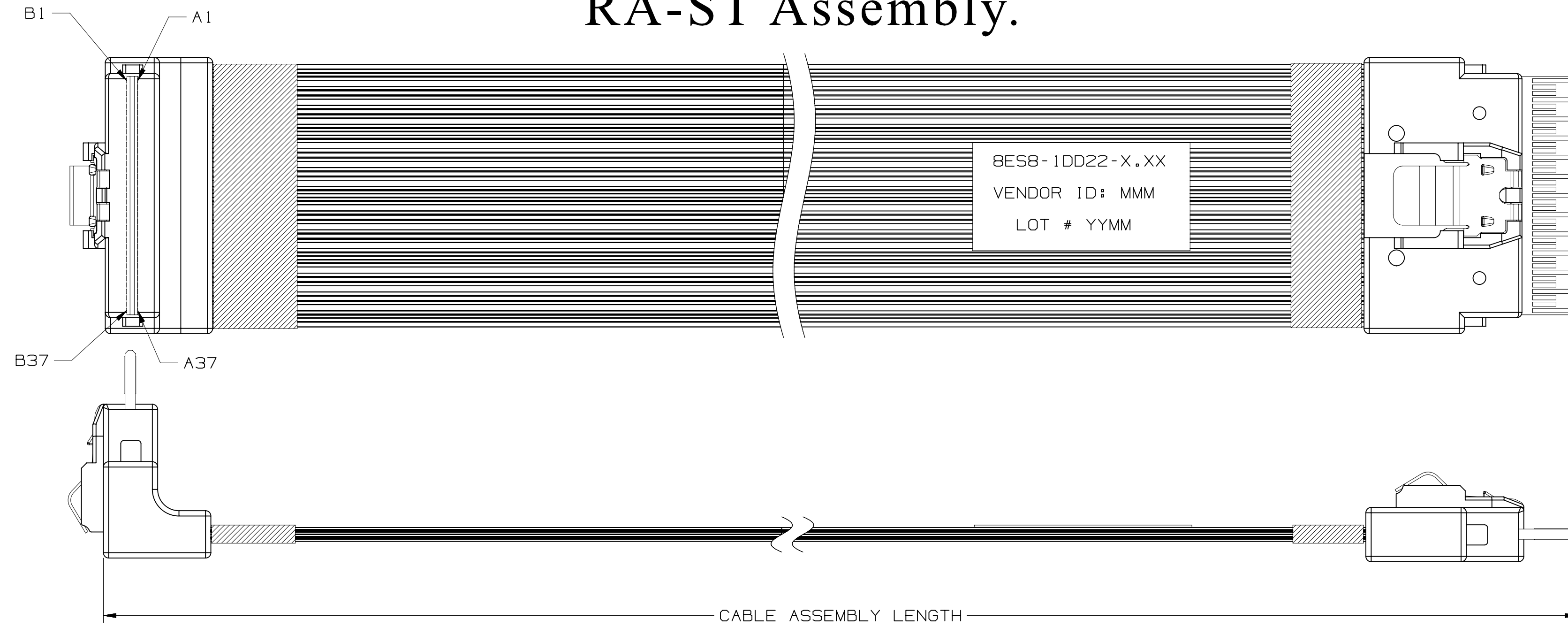

RA-RA Assembly.

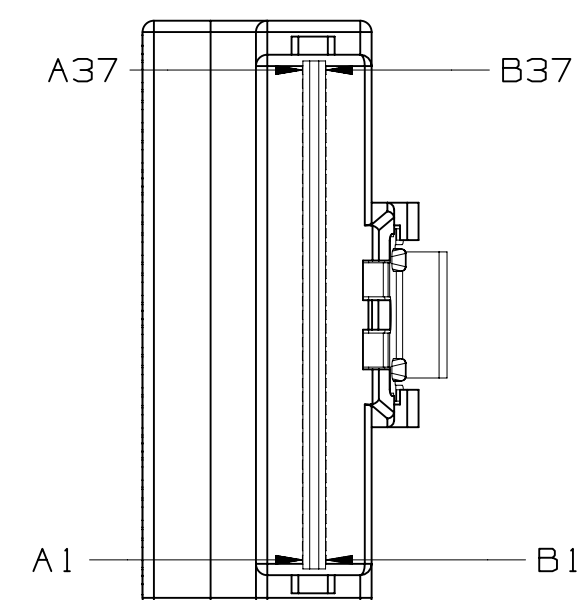
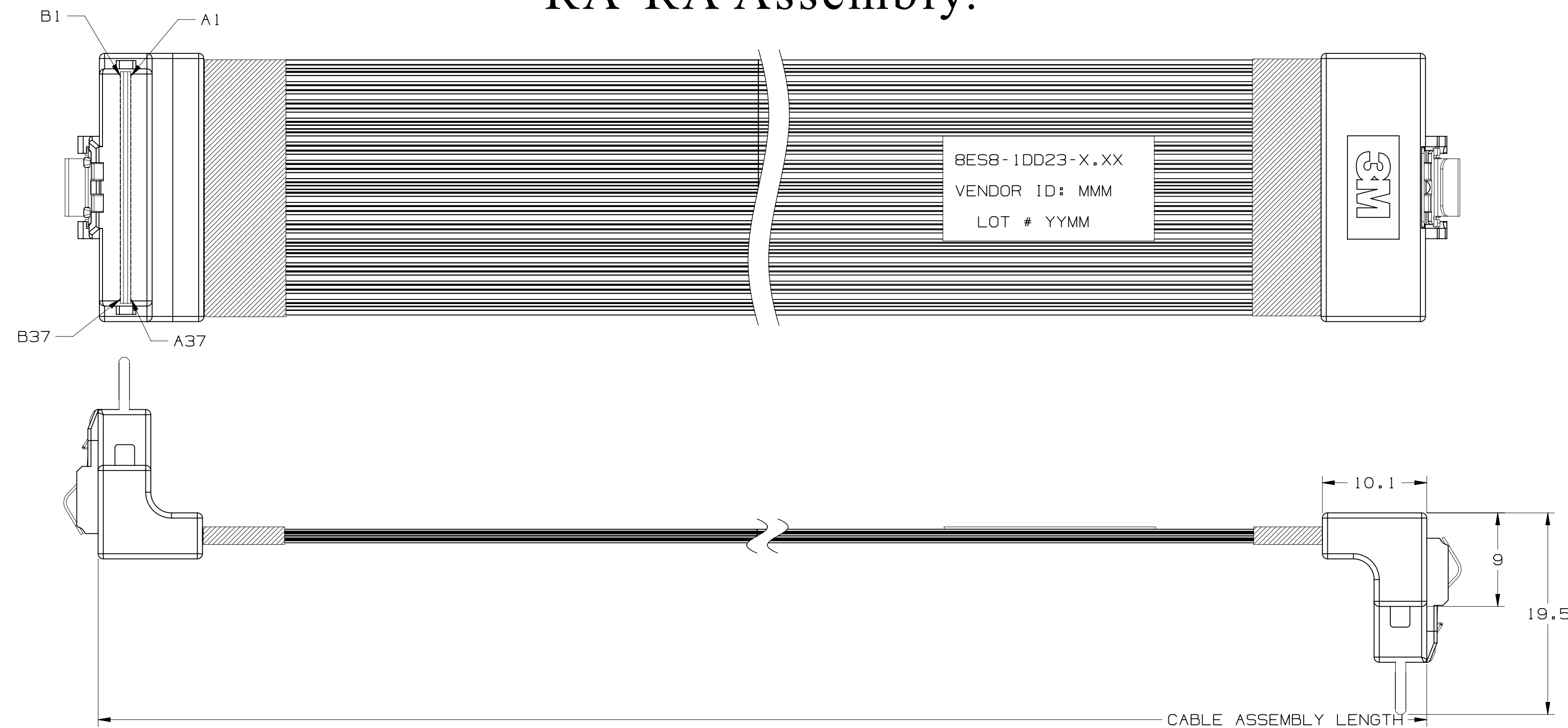

**Technical Information:** The technical information, recommendations and other statements contained in this document are based upon tests or experience that 3M believes are reliable, but the accuracy or completeness of such information is not guaranteed.

**Product Use:** Many factors beyond 3M's control and uniquely within user's knowledge and control can affect the use and performance of a 3M product in a particular application. Given the variety of factors that can affect the use and performance of a 3M product, user is solely responsible for evaluating the 3M product and determining whether it is fit for a particular purpose and suitable for user's method of application.

**Warranty, Limited Remedy, and Disclaimer:** Unless an additional warranty is specifically stated on the applicable 3M product packaging or product literature, 3M warrants that each 3M product meets the applicable 3M product specification at the time 3M ships the product. 3M MAKES NO OTHER WARRANTIES OR CONDITIONS, EXPRESS OR IMPLIED, INCLUDING, BUT NOT LIMITED TO, ANY IMPLIED WARRANTY OR CONDITION OF MERCHANTABILITY OR FITNESS FOR A PARTICULAR PURPOSE OR ANY IMPLIED WARRANTY OR CONDITION ARISING OUT OF A COURSE OF DEALING, CUSTOM OR USAGE OF TRADE. If the 3M product does not conform to this warranty, then the sole and exclusive remedy is, at 3M's option, replacement of the 3M product or refund of the purchase price.

**Limitation of Liability:** Except where prohibited by law, 3M will not be liable for any loss or damage arising from the 3M product, whether direct, indirect, special, incidental or consequential, regardless of the legal theory asserted, including warranty, contract, negligence or strict liability.

DESIGN REFERENCE	NEXT ASSEMBLY	REV	ECD	ISSUE DATE AND DESCRIPTION	DRFT	CHKD
		B	B1149	JAN 14, 2019 CHANGE MIN. LENGTH	VT	VT
		A	73021	MAR 27, 2017	Rao	Rao
ACCESS CODES	US882 S8830a	DRFT	Rao Vittapalli	MAR 27, 2017	DATE	DATE
		CHKD	Rao Vittapalli	MAR 27, 2017	DATE	DATE
		APPR	Saujit Bandhu	MAR 27, 2017	DATE	DATE
DIVISION		DIVISION CODE				
DO NOT SCALE DRAWING	SCALE	TOLERANCES EXCEPT AS NOTED				
		INCHES				
		MILLIMETERS				
THIRD ANGLE PROJECTION		INTERPRET PER ASME Y14.5 - 2009				
		MAX SURFACE ROUGHNESS				
125		ALL SURFACES				
		MARKED ONLY				
		ANGLES ±1°				
TITLE		CAGE NUMBER				
CUSTOMER DRAWING SLIMLINE 85 OHM X8 31AWG CABLE ASSY		D 78-5100-2675-6				
3M Center St. Paul, MN 55144		© 3M COPYRIGHT 2019. This document and the information it contains are 3M property and may not be reproduced or further distributed without 3M permission, or used or disclosed other than for 3M authorized purposes. All rights reserved.				
MODEL		SHT 2 OF 2				