

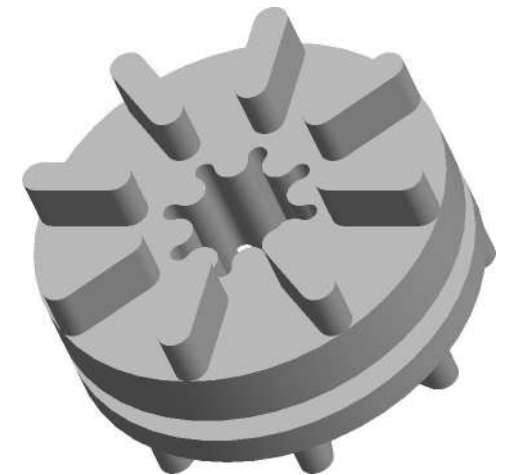

REVISIONS				
DRAWN	REV	DESCRIPTION	DATE	APPROVED
DH	00	ORIGINAL	8-26-98	DC
KP/TC	01	UPDATED FORMAT, NOTES, TOLERANCES, ADDED WEIGHT, CAVITY LOCATION, AND -X TO NAMING CONVENTION.	9-8-11	MS

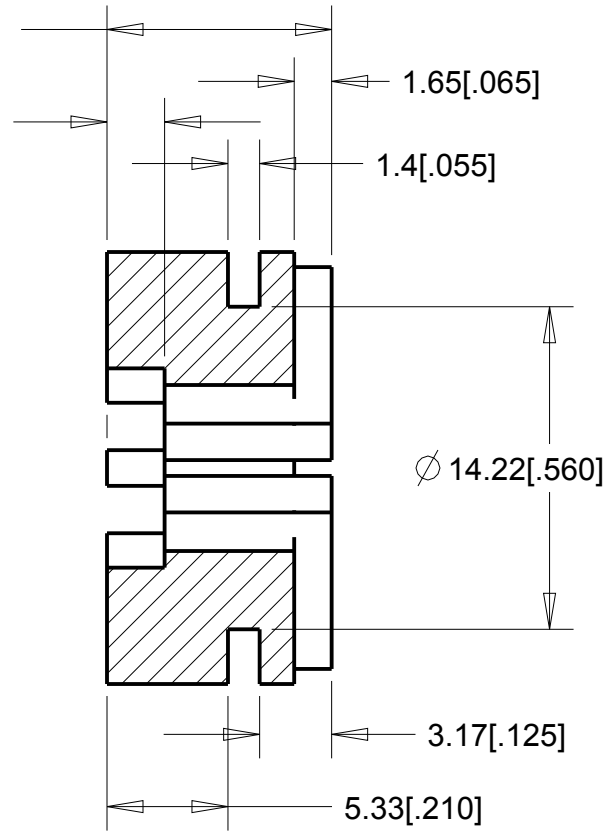
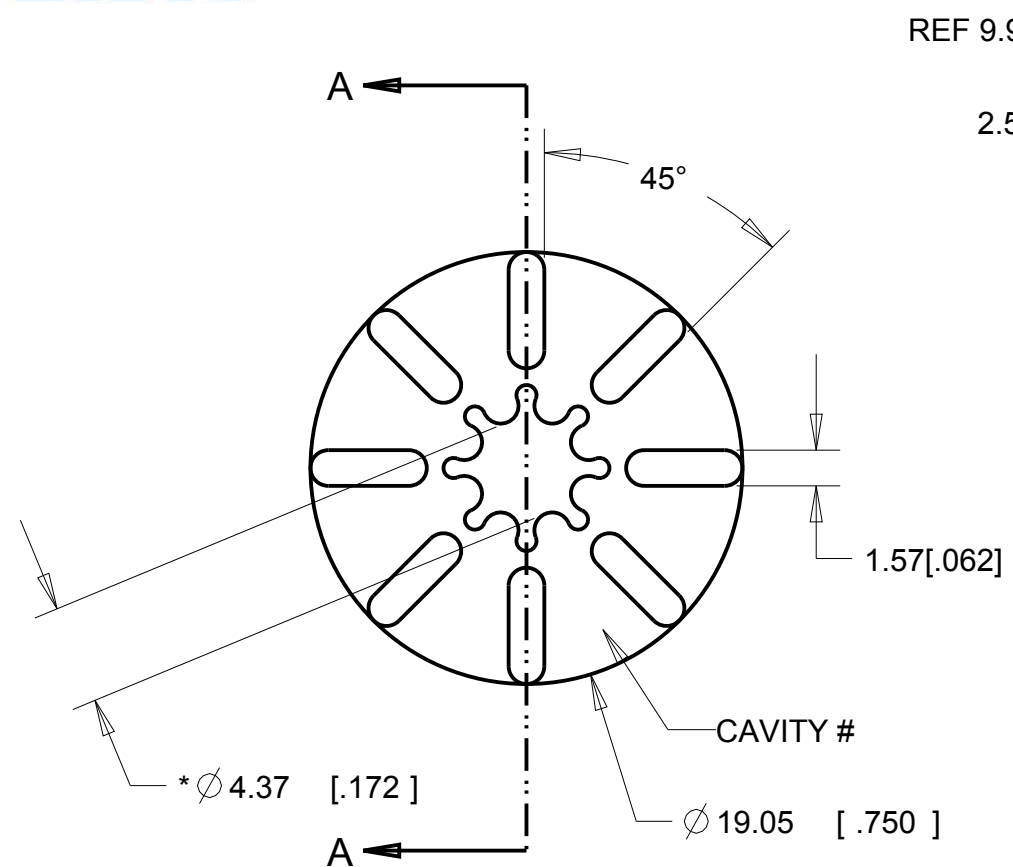

SECTION A-A

- 5. FOR ISOLOSS MATERIAL, USE THE TOLERANCE TABLE ON PAGE 2
- 4. FOR VERSADAMP AND ISODAMP MATERIAL, USE THE TOLERANCE TABLE ON PAGE 1
- 3. MAX DRAFT ALLOWED: 2°
- 2. CRITICAL DIMENSIONS SHALL HAVE C_pk VALUE >= 1.33 WITH ONGOING SPC DATA REQUIRED
- 1. CRITICAL DIMENSIONS ARE MARKED WITH "**".

NOTES:

GROMMET MATERIAL	SEE PAGE
ISODAMP	1
VERSADAMP	1
ISOLOSS	2

G-431-C8012	C-8012
G-431-C8002	C-8002
G-431-C8001	C-8001
G-431-V2325	V-2325
G-431-3	C-1100
G-431-2	C-1105
G-431-1	C-1002
PART NUMBER	MATERIAL

RANGE	TOL
0<D=<2 [.079]	± 0.15 [.006]
2 [.079]<D=<25 [.984]	± 0.25 [.010]
25 [.984]<D=<50 [1.969]	± 0.4 [.016]
50 [1.969]<D	± 0.6 [.024]

UNLESS OTHERWISE SPECIFIED UNITS ARE: MM [IN] TOLERANCES ARE IN THE TABLE TO THE LEFT: ANGLES ±1.0 °	MATERIAL: SEE TABLE ON LEFT	AEARO TECHNOLOGIES LLC * a 3M company		
	ALLOWABLE FLASH: 0.12 MM [.005]	QUALITY CONTROL: MUST COMPLY WITH AEARO TECHONLOGIES LLC SUPPLIER QUALITY MANUAL REQUIREMENTS	TITLE GROMMET - ASYMMETRIC	
GATE: ±0.15MM [.006]	NOTES: ANY FEATURE NOT DIMENSIONED IN PRINT MUST BE VISIBLY PRESENT, UTILIZE 3D CAD FOR CREATION	SIZE B	ITEM CODE	DWG NO. G-431-X PAGE 1 OF 2
CALC WT 2.08 GRAM REF				



REVISIONS

D

D

C

C

B

B

A

A

G-431-SL60300	SL-60300
G-431-SL50300	SL-50300
G-431-SL35300	SL-35300
G-431-SL20300	SL-20300
PART NUMBER	MATERIAL

RANGE	TOL
0<D=<10 [.394]	± 0.15 [.006]
10 [.394]<D=<20 [.787]	± 0.2 [.008]
20 [.787]<D=<50 [1.969]	± 0.25 [.010]
50 [1.969]<D=<80 [3.150]	± 0.35 [.014]
80 [3.150]<D	±0.5%

UNLESS OTHERWISE SPECIFIED UNITS ARE: MM [IN] TOLERANCES ARE IN THE TABLE TO THE LEFT: ANGLES ±1.0 °	MATERIAL: SEE TABLE ON LEFT	AEARO TECHNOLOGIES LLC * a 3M company	
	ALLOWABLE FLASH: 0.3 MM [0.012]	QUALITY CONTROL: MUST COMPLY WITH AEARO TECHONOLGIES LLC SUPPLIER QUALITY MANUAL REQUIREMENTS	TITLE GROMMET - ASYMMETRIC
GATE:	NOTES: ANY FEATURE NOT DIMENSIONED IN PRINT MUST BE VISIBLY PRESENT, UTILIZE 3D CAD FOR CREATION	SIZE B	ITEM CODE
CALC WT 1.76 GRAM REF		DWG NO. G-431-X PAGE 2 OF 2	

1

2

3

4