

Q4X Stainless Steel Laser Sensor with Dual Discrete Outputs and IO-Link

Instruction Manual

Original Instructions
190074 Rev. I
11 January 2023
© Banner Engineering Corp. All rights reserved



190074

Contents

1 Product Description	4
1.1 Models	4
1.2 Overview	4
1.3 Features	5
1.3.1 Display and Indicators	5
1.3.2 Buttons	5
1.4 Laser Description and Safety Information	6
2 Installation	7
2.1 Install the Safety Label	7
2.2 Sensor Orientation	7
2.3 Mount the Device	8
2.4 Wiring Diagram	8
2.5 Connecting to RSD1	8
3 Sensor Programming	9
3.1 Channel 1 and Channel 2 (CH1/CH2)	9
3.2 Setup Mode	9
3.2.1 Output	11
3.2.2 TEACH Mode	12
3.2.3 Adaptive Tracking	12
3.2.4 Window Size	13
3.2.5 Response Speed—100/110/300/310 mm Models	13
3.2.6 Response Speed—600/610 mm Models	13
3.2.7 Gain and Sensitivity	14
3.2.8 Output Timing Delays	14
3.2.9 Zero Reference Location	15
3.2.10 Shift the Zero Reference Location after a TEACH	16
3.2.11 Offset	16
3.2.12 Display View	17
3.2.13 Exit Setup Mode	17
3.2.14 Reset to Factory Defaults	17
3.3 Manual Adjustments	18
3.4 Remote Input	18
3.4.1 Select the TEACH Mode Using the Remote Input	19
3.4.2 Reset to Factory Defaults Using the Remote Input	19
3.5 Locking and Unlocking the Sensor Buttons	19
3.6 TEACH Procedures	20
3.6.1 Two-Point Static Background Suppression	20
3.6.2 Dynamic Background Suppression	22
3.6.3 One-Point Window (Foreground Suppression)	23
3.6.4 One-Point Background Suppression	26
3.6.5 Dual (Intensity + Distance)	27
3.7 Pulse Frequency Modulation (PFM) Output	29
3.8 Sync Master/Slave	29
4 IO-Link Interface	30
5 Specifications	31
5.1 FCC Part 15 Class A	33
5.2 Industry Canada	34
5.3 Dimensions	34
5.4 Performance Curves—Threaded Barrel Models	36
5.5 Performance Curves—Flush Mount Models	37
6 Additional Information	38
6.1 Dual (Intensity + Distance) Mode	38
6.2 Dual Mode Reference Surface Considerations	38
6.3 Dual Mode Considerations for Clear and Transparent Object Detection	39
6.4 Abbreviations	40
7 Troubleshooting	43
8 Accessories	44
8.1 Cordsets	44
8.2 Sensor Status Indicators	46
8.3 Brackets	47
8.4 RSD1 Remote Display	47
8.5 Aperture Kits—Threaded Barrel Models	48
8.6 Reference Targets	48

9 Product Support and Maintenance 50
9.1 Cleaning and Maintenance 50
9.2 Contact Us 50
9.3 Banner Engineering Corp. Limited Warranty 50

1 Product Description

Class 1 laser CMOS sensor with dual outputs and IO-Link. Patent pending.

Figure 1. Flush Mount (Left) and Threaded Barrel (Right) Models

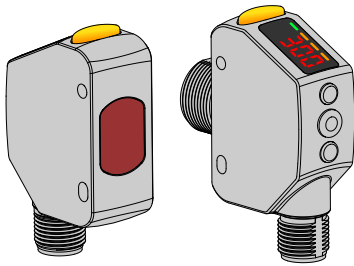

- The ultimate problem solver: reduce sensor inventory with a reliable, durable sensor that solves the most challenging applications
- Solves difficult distance-based applications regardless of target surface reflectivity, including black foam on black plastic, black rubber in front of metal, transparent objects, multicolor packaging, and targets of all colors
- Robust housing rated to IP69K with FDA-grade stainless steel resists mechanical impact, over tightening and extreme vibration
- Bright output indicator and real time distance feedback provide easy setup and troubleshooting for reduced installation costs
- Dual channels and IO-Link



For illustration purposes, the threaded barrel model Q4X images are used throughout this document.



WARNING:

- **Do not use this device for personnel protection**
- Using this device for personnel protection could result in serious injury or death.
- This device does not include the self-checking redundant circuitry necessary to allow its use in personnel safety applications. A device failure or malfunction can cause either an energized (on) or de-energized (off) output condition.

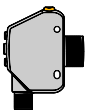
1.1 Models

Model	Sensing Range	Channel 1	Channel 2	Connection
	Q4XTKLAF600-Q8 25 mm to 600 mm (0.98 in to 23.62 in)	IO-Link, Push/pull output	PNP only output or input, or pulse frequency modulated output	Integral 4-pin M12 male quick-disconnect connector
	Q4XTKLAF300-Q8 25 mm to 300 mm (0.98 in to 11.81 in)			
	Q4XTKLAF100-Q8 25 mm to 100 mm (0.98 in to 3.94 in)			
	Q4XFKLAF610-Q8 35 mm to 610 mm (1.38 in to 24.02 in)	IO-Link, Push/pull output	PNP only output or input, or pulse frequency modulated output	Integral 4-pin M12 male quick-disconnect connector
	Q4XFKLAF310-Q8 35 mm to 310 mm (1.38 in to 12.20 in)			
	Q4XFKLAF110-Q8 35 mm to 110 mm (1.38 in to 4.33 in)			

1.2 Overview

The Q4X Sensor with Dual Discrete Outputs and IO-Link is a Class 1 laser CMOS sensor with an IO-Link and multifunction output. The normal sensor state is Run mode. From Run mode, the switch point value and channel selection can be changed and the selected TEACH method can be performed. The secondary sensor state is Setup mode. From Setup mode, the TEACH mode can be selected, all standard operating parameters can be adjusted, and a factory reset can be done.

1.3 Features

Figure 2. Sensor Features

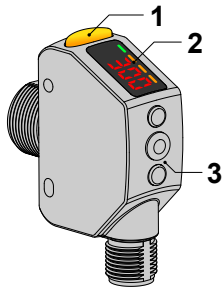

1. Output Indicator (Amber)
2. Display
3. Buttons

1.3.1 Display and Indicators

The display is a 4-digit, 7-segment LED. The main screen is the Run mode screen.

For 2-pt, BGS, FGS, and DYN TEACH modes, the display shows the current distance to the target in millimeters. For dual TEACH mode, the display shows the percentage matched to the taught reference surface. A display value of **9999** indicates the sensor has not been taught.

Figure 3. Display in Run Mode



1. Stability Indicator (STB—Green)
2. Active TEACH Indicators
 - DYN—Dynamic (Amber)
 - FGS—Foreground Suppression (Amber)
 - BGS—Background Suppression (Amber)



Note: The indicators represent the currently selected channel. However, if Output 2 is set to something other than LO, DO, or Complementary, then the indicators represent the Channel 1 status.

Output Indicator

- On—Output is on
- Off—Output is off

Stability Indicator (STB)

- On—Stable signal within the specified sensing range
- Flashing—Marginal signal, the target is outside the limits of the specified sensing range, or a multiple peak condition exists
- Off—No target detected within the specified sensing range

Active TEACH Indicators (DYN, FGS, and BGS)

- DYN, FGS, and BGS all off—Two-point TEACH mode selected (default)
- DYN on—Dynamic TEACH mode selected
- FGS on—Foreground suppression TEACH mode selected
- BGS on—Background suppression TEACH mode selected
- DYN, FGS, and BGS all on—Dual TEACH mode selected

1.3.2 Buttons

Use the sensor buttons (**SELECT**)(**TEACH**), **(+)(CH1/CH2)**, and **(-)(MODE)** to program the sensor.

Figure 4. Buttons

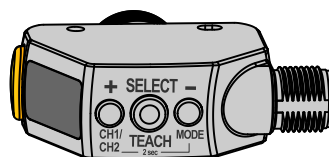

(SELECT)(TEACH)

- Press to select menu items in Setup mode
- Press and hold for longer than 2 seconds to start the currently selected TEACH mode (the default is two-point TEACH)

(+)(CH1/CH2)

- Press to navigate the sensor menu in Setup mode
- Press to change setting values; press and hold to increase numeric values
- Press and hold for longer than 2 seconds to switch between Channel 1 and Channel 2

(-)(MODE)

- Press to navigate the sensor menu in Setup mode
- Press to change setting values; press and hold to decrease numeric values
- Press and hold for longer than 2 seconds to enter Setup mode



Note: When navigating the menu, the menu items loop.

1.4 Laser Description and Safety Information



CAUTION:

- **Return defective units to the manufacturer.**
- Use of controls or adjustments or performance of procedures other than those specified herein may result in hazardous radiation exposure.
- Do not attempt to disassemble this sensor for repair. A defective unit must be returned to the manufacturer.

≤ 510 mm Models - IEC 60825-1:2007 Class 1 Laser

Class 1 lasers are lasers that are safe under reasonably foreseeable conditions of operation, including the use of optical instruments for intrabeam viewing.

COMPLIES WITH 21 CFR 1040.10 AND 1040.11 EXCEPT FOR DEVIATIONS PURSUANT TO LASER NOTICE No. 50, DATED JUNE 24, 2007. BANNER ENGINEERING CORP. 9714 10TH AVENUE NORTH MINNEAPOLIS, MN 55441	<div style="border: 2px solid black; padding: 5px; width: fit-content; margin: 0 auto;"> CLASS 1 LASER PRODUCT </div>	COMPLIES WITH IEC 60825-1:2007
---	--	--------------------------------

Laser wavelength: 655 nm

Output: < 0.20 mW

Pulse Duration: 7 μs to 2 ms

> 510 mm Models - IEC 60825-1:2014 Class 1 Laser

Class 1 lasers are lasers that are safe under reasonably foreseeable conditions of operation, including the use of optical instruments for intrabeam viewing.

COMPLIES WITH 21 CFR 1040.10 AND 1040.11 EXCEPT FOR CONFORMANCE WITH IEC 60825-1:2014, AS DESCRIBED IN LASER NOTICE No. 56, DATED MAY 8, 2019. BANNER ENGINEERING CORP. 9714 10TH AVENUE NORTH MINNEAPOLIS, MN 55441	<div style="border: 2px solid black; padding: 5px; width: fit-content; margin: 0 auto;"> CLASS 1 LASER PRODUCT </div>	COMPLIES WITH IEC 60825-1:2014
--	--	--------------------------------

Laser wavelength: 655 nm

Output: < 0.39 mW

Pulse Duration: 7 μs to 2 ms

2 Installation

2.1 Install the Safety Label

The safety label must be installed on Q4X sensors that are used in the United States.



Note: Position the label on the cable in a location that has minimal chemical exposure.

1. Remove the protective cover from the adhesive on the label.
2. Wrap the label around the Q4X cable, as shown.
3. Press the two halves of the label together.

Figure 5. Safety Label Installation

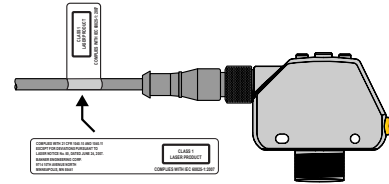

2.2 Sensor Orientation

Optimize detection reliability and minimum object separation performance with correct sensor-to-target orientation. To ensure reliable detection, orient the sensor as shown in relation to the target to be detected.

Figure 6. Optimal Orientation of Target to Sensor

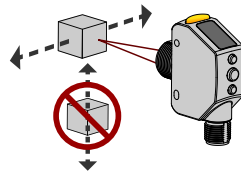

See the following figures for examples of correct and incorrect sensor-to-target orientation as certain placements may pose problems for sensing some targets. The Q4X can be used in the less preferred orientation and provide reliable detection performance; refer to the *Performance Curves* for the minimum object separation distance required for each case.

Figure 7. Orientation by a wall

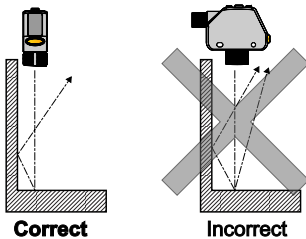

Figure 8. Orientation for a turning object

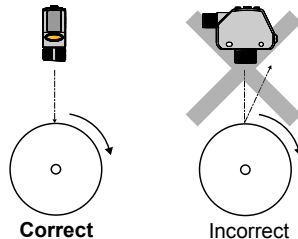

Figure 9. Orientation for a height difference

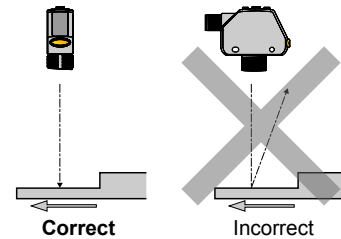

Figure 10. Orientation for a color or luster difference

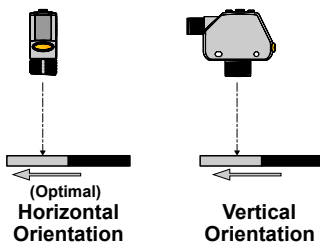
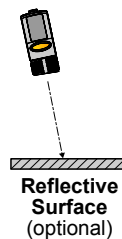

Figure 11. Orientation for highly reflective target ¹



¹ Applying tilt to sensor may improve performance on reflective targets. The direction and magnitude of the tilt depends on the application, but a 15° tilt is often sufficient.

2.3 Mount the Device

1. If a bracket is needed, mount the device onto the bracket.
2. Mount the device (or the device and the bracket) to the machine or equipment at the desired location. Do not tighten the mounting screws at this time.
3. Check the device alignment.
4. Tighten the mounting screws to secure the device (or the device and the bracket) in the aligned position.

2.4 Wiring Diagram

Figure 12. Channel 2 as PNP discrete or PFM output

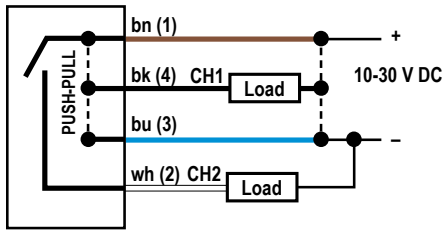
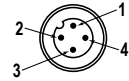
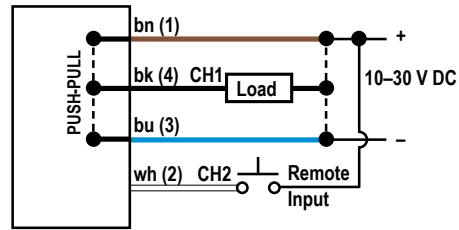

Figure 13. Channel 2 as remote input



Key
 1 = Brown
 2 = White
 3 = Blue
 4 = Black



Note: Open lead wires must be connected to a terminal block.



Note: The Channel 2 wire function is user-selectable. The default for the wire is PNP output. See the Instruction Manual for details regarding use as remote input or PFM output.

2.5 Connecting to RSD1

The following diagram depicts the connection of the Q4XTKLAF600 or the Q4XTKLAF610 to the optional RSD1 accessory.

Figure 14. Q4X to RSD1

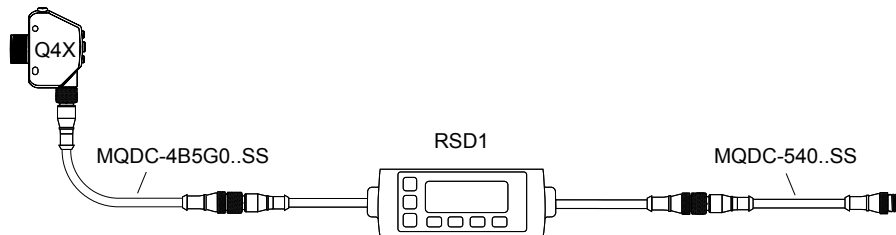

3 Sensor Programming

Program the sensor using the buttons on the sensor or the remote input (limited programming options).

In addition to programming the sensor, use the remote input to disable the buttons for security, preventing unauthorized or accidental programming changes. See for more information.

3.1 Channel 1 and Channel 2 (CH1/CH2)

Press CH1/CH2 button to switch between Channel 1 and Channel 2.

Within each channel there are options specific to that channel. For settings that are common to both channels, the menus are only available in Channel 1. The default is Channel 1.

To switch between Channel 1 and Channel 2:

1. Press and hold **CH1/CH2** for longer than 2 seconds. The current selection displays.
2. Press **CH1/CH2** again. The new selection flashes slowly.
3. Press **SELECT** to change the Channel and return to Run mode.



Note: If neither **SELECT** nor **CH1/CH2** are pressed after step 2, the new selection flashes slowly for a few seconds, then flashes quickly and the sensor automatically changes the Channel and returns to Run mode.

3.2 Setup Mode

Access Setup mode and the sensor menu from Run mode by pressing and holding **MODE** for longer than 2 seconds. Use

+ and **-** to navigate through the menu. Press **SELECT** to select a menu option and access the submenus. Use **+** and **-** to navigate through the submenus. Press **SELECT** to select a submenu option and return to the top menu, or press and hold **SELECT** for longer than 2 seconds to select a submenu option and return immediately to Run mode.

To exit Setup mode and return to Run mode, navigate to *End* and press **SELECT**.



Note: The number that follows a menu option, for example *ch 1*, indicates the channel that is selected. For menu items without a number (excluding submenu items), these menu options are only available from Channel 1 and the settings apply to both channels.

Figure 15. Sensor Menu Map—Channel 1

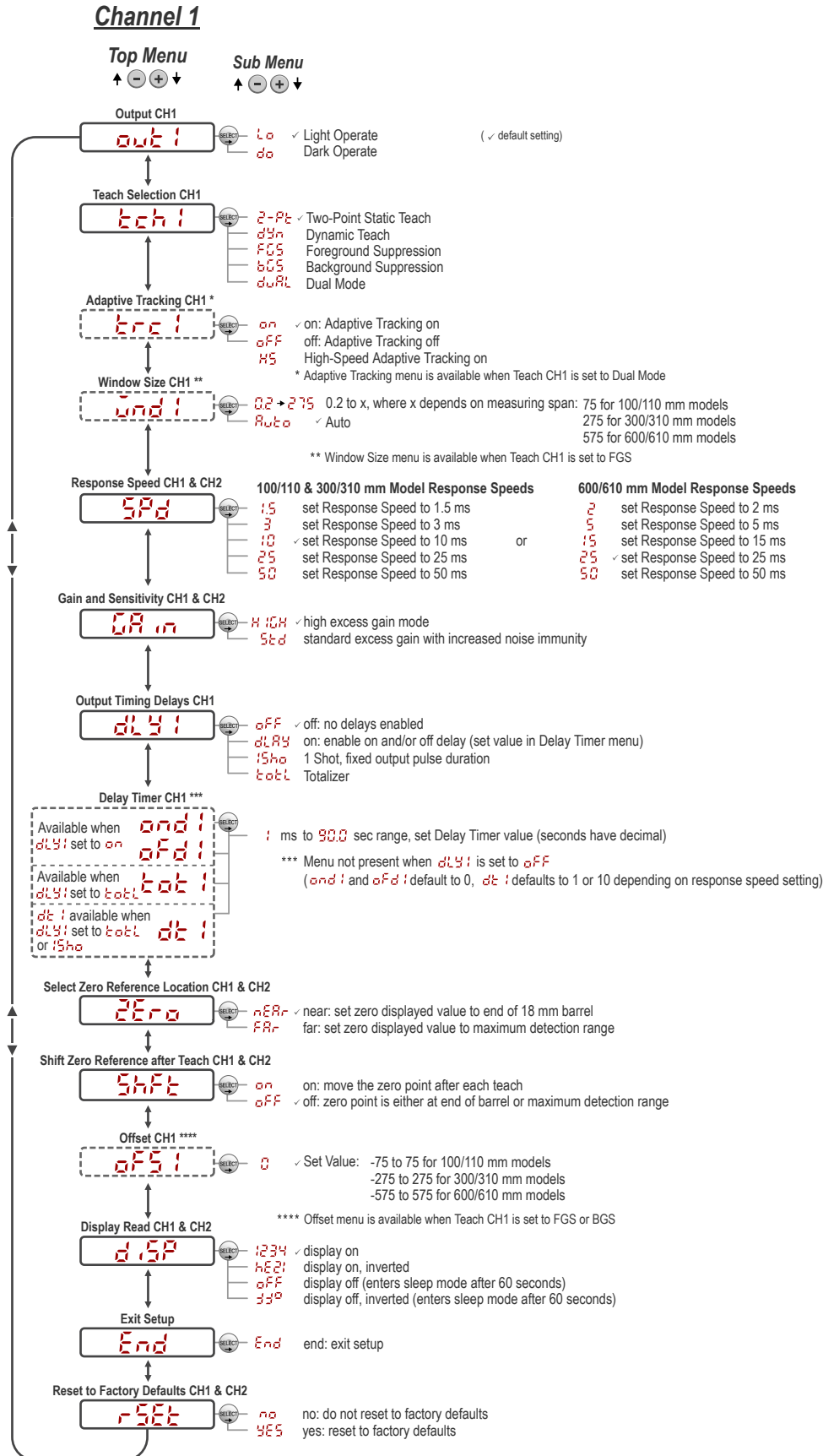
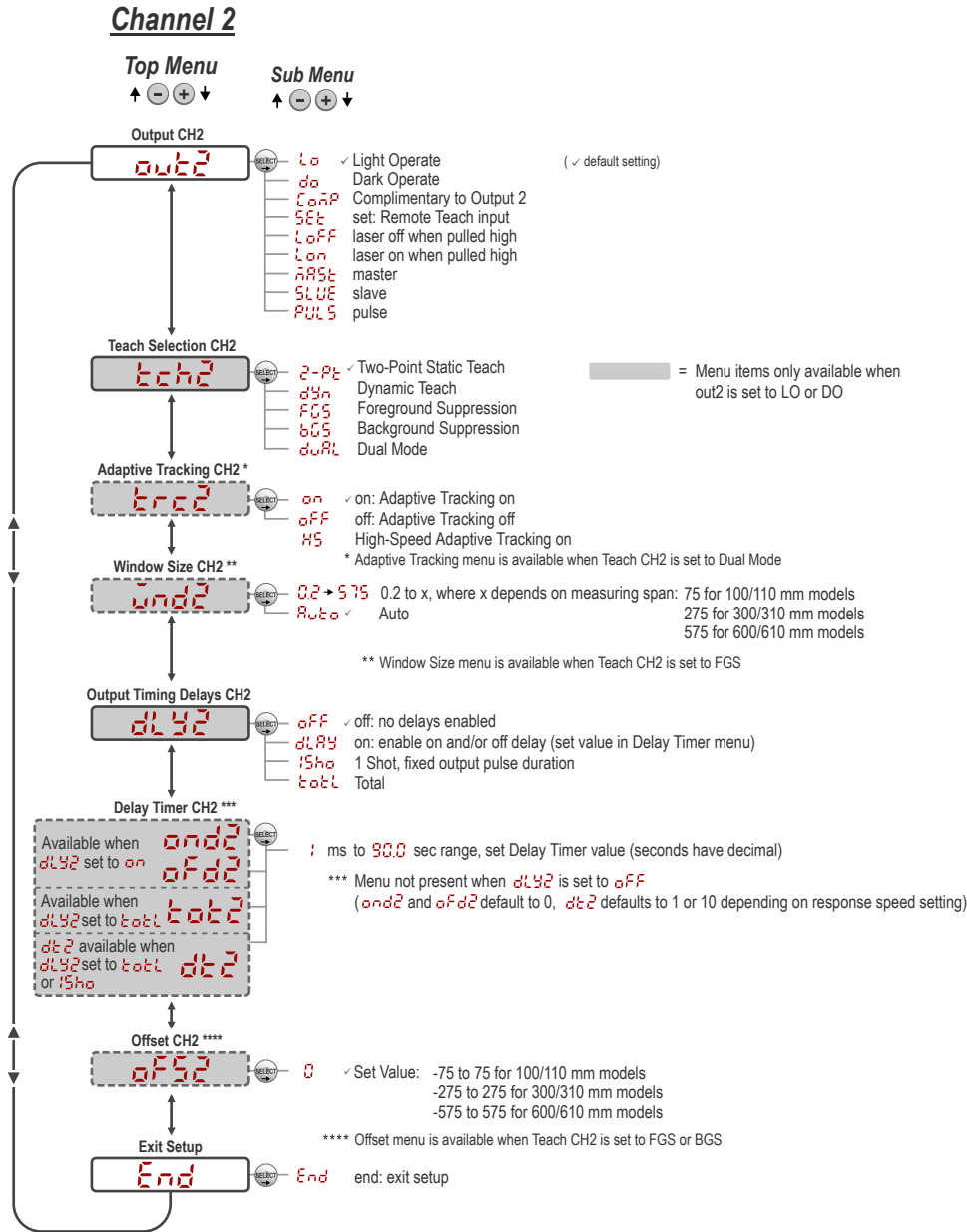

Figure 16. Sensor Menu Map—Channel 2



3.2.1 Output out1 out2

The Output 1 and Output 2 menus differ between Channel 1 and Channel 2.



Note: The number that follows **out** on the display indicates which channel is selected.

The Output 1 menu is available in Channel 1. Use this menu to select light operate (LO) or dark operate (DO). The default output configuration is light operate. To switch between light operate and dark operate, select the desired menu option.

- Lo —Light operate
- do —Dark operate

The Output 2 menu is available in Channel 2. Use this menu to set the output configuration for Channel 2. The default is light operate.

- Lo —Light operate
- do —Dark operate

- **COMP** —Complementary to output 1
- **SET** —Remote TEACH input
- **LOFF** —Laser off when pulled high
- **L ON** —Laser on when pulled high
- **MASTER** —Master sync line output for two-sensor cross-talk avoidance
- **SLAVE** —Slave sync line output for two-sensor cross-talk avoidance
- **PULS** —Pulse Frequency Modulation (PFM) output (see [Pulse Frequency Modulation \(PFM\) Output](#) on page 29)

To configure the sensor for master-slave operation, see [Sync Master/Slave](#) on page 29.

3.2.2 TEACH Mode **tch 1 tch 2**

Use this menu to select the TEACH mode.

The default is two-point TEACH. For Channel 2, this menu is available when the output is set to light operate or dark operate.



Note: The number that follows **tch** on the display indicates which channel is selected.

- **2-PT** —Two-point static background suppression
- **dyn** —Dynamic background suppression
- **FGS** —One-point window (foreground suppression)
- **BGS** —One-point background suppression
- **dual** —Dual (intensity + distance) window

After the TEACH mode is selected, from Run mode, press and hold **TEACH** for longer than 2 seconds to start the TEACH mode and program the sensor. See [TEACH Procedures](#) on page 20 for additional information and remote input TEACH instructions.

3.2.3 Adaptive Tracking **trc 1 trc 2**

In adaptive tracking mode, the laser intensity changes to compensate for a loss in excess gain - normally caused by a dirty lens.

When operating in dual mode, the Adaptive Tracking Algorithm adjusts the switching thresholds (distance and intensity) around a taught reference surface. Adaptive tracking adjusts for small variations in the reference surface to maintain a consistent 100P (100%) on the display and to ensure reliable detection. The Adaptive Tracking menu is only available when Teach Ch1 is set to Dual Mode.

Adjustment of the thresholds only occurs when the reference surface is visible to the sensor (that is, no target is present). The Adaptive Tracking Algorithm can reduce or eliminate the need to periodically re-teach the sensor as environmental conditions change around the sensor.

Enable or disable the Adaptive Tracking Algorithm from the sensor menu. The appropriate speed depends on the application. This menu is available only if dual (intensity + distance) mode is selected. For Channel 2, the output must be set to light operate or dark operate.



Note: The number that follows **trc** on the display indicates which channel is selected.

- **HS** —High-Speed Adaptive Tracking On
- **on** —Adaptive Tracking On (default)
- **off** —Adaptive Tracking Off

OFF disables the Adaptive Tracking Algorithm—Prevents the sensor from adjusting the thresholds around the taught reference surface while the sensor is in dual mode. The sensor will not adapt to or learn any target. Environmental changes may cause the displayed value to deviate from 100P (100%) over time. A periodic re-teach of the reference surface may be required to restore the displayed value to 100P if this is important to the application.

There are some cases in which disabling adaptive tracking is useful. For example, disable adaptive tracking if the target passes very slowly through the sensing beam, if the target might stop while partially blocking the beam, and if the environmental conditions are stable.

ON enables the Adaptive Tracking Algorithm at the standard speed—Recommended for many applications detecting low contrast targets. Standard adaptive tracking adjusts the thresholds around slowly changing background and environmental conditions. It adjusts the sensor for stable detection when the environment changes due to gradual dust

accumulation, machine vibration, or ambient temperature changes which influence the signal from the reference surface. Standard adaptive tracking will not easily adapt to or learn slow moving, low contrast targets (for example, clear targets entering and exiting the beam over approximately 2 seconds).

HS enables the Adaptive Tracking Algorithm at high speed—Optional adaptive tracking setting used with dual mode. Use high speed adaptive tracking when the signal from the reference surface changes quickly due to unstable environmental conditions and high contrast and high-speed targets are being detected. High speed adaptive tracking adjusts the sensor for stable detection in challenging environmental conditions such as dust accumulation, machine vibration, ambient temperature changes, or a non-stable reference surface (for example, a running belt or web which influences the signal from the reference surface). For example, if the signal from the reference surface changes by 10% due to environmental effects, high speed adaptive tracking adjusts the displayed value back to 100P (100%) over 2 to 3 seconds.

High speed adaptive tracking addresses certain applications where the reference surface is not stable, but the sensor must detect high speed and high contrast targets reliably. With high speed adaptive tracking there is the potential for the sensor to adapt the thresholds to slow moving or low contrast targets, leading to missed detection events. If the detection events are generating small signal changes of similar magnitude to the background changes, detection problems are likely. Stabilize the reference surface to avoid this problem.

3.2.4 Window Size

This menu is available only if one-point window (foreground suppression) mode is selected. The default selection is Auto, where the FGS window size is automatically calculated.

This menu can be used to manually set a window size. See the following table for the window size range:

Window Size	Models
0.1 mm to 75 mm	100 mm and 110 mm models
0.2 mm to 275 mm	300 mm and 310 mm models
0.2 mm to 575 mm	600 mm and 610 mm models

This setting is automatically applied during any subsequent teach operation. The window size value represents a +/- mm value, so the total window size is twice this value. For example, a window set of 10 mm gives a 20 mm window centered around the taught point. The window size can also be changed directly from Run mode after changing the setting to any value except Auto. For Channel 2, the output must be set to light operate or dark operate.

3.2.5 Response Speed —100/110/300/310 mm Models

Use this menu to select the response speed. The default is 10 milliseconds.

-  —1.5 milliseconds
-  —3 milliseconds
-  —10 milliseconds
-  —25 milliseconds
-  —50 milliseconds

Table 1: Tradeoffs

Response Speed	Response Speed in Sync Mode	Repeatability	Ambient Light Rejection	Excess Gain
1.5 ms	3 ms	500 μ s	Disabled	See the Excess gain table for your model in Specifications on page 31
3 ms	6 ms	500 μ s	Enabled	
10 ms	20 ms	2 ms	Enabled	
25 ms	50 ms	5 ms	Enabled	
50 ms	100 ms	10 ms	Enabled	

3.2.6 Response Speed —600/610 mm Models

Use this menu to select the response speed. The default is 25 milliseconds.

-  —2 milliseconds

- **5** —5 milliseconds
- **15** —15 milliseconds
- **25** —25 milliseconds
- **50** —50 milliseconds

Table 2: Tradeoffs

Response Speed	Response Speed in Sync Mode	Repeatability	Ambient Light Rejection	Excess Gain
2 ms	4 ms	800 μ s	Disabled	See the Excess gain table for your model in Specifications on page 31
5 ms	10 ms	1600 μ s	Enabled	
15 ms	30 ms	3 ms	Enabled	
25 ms	50 ms	5 ms	Enabled	
50 ms	100 ms	10 ms	Enabled	

3.2.7 Gain and Sensitivity **GA n**

Use this menu to set the excess gain mode. This menu is only available when a 10, 15, 25, or 50 millisecond response speed is selected. It is not available for 1.5, 2, 3, or 5 millisecond response speeds.

- **HIGH** —High excess gain mode
- **Std** —Standard excess gain mode with increased noise immunity

3.2.8 Output Timing Delays **dLY 1 dLY 2**

Use this menu to select the output timing delay to be set.

On and off delay timers can be used together. The default is no delay. For Channel 2, this menu is available when the output is set to light operate or dark operate.



Note: The number that follows **dLY** on the display indicates which channel is selected.

- **off** —No delay
- **dLY** —Delay—enables the selection of on and off delay timers
- **1-Shot** —One-shot—enables a one-shot, fixed output pulse duration
- **totl** — Totalizer—enables an output after a defined number of targets are counted

Figure 17. Output Timing Delays

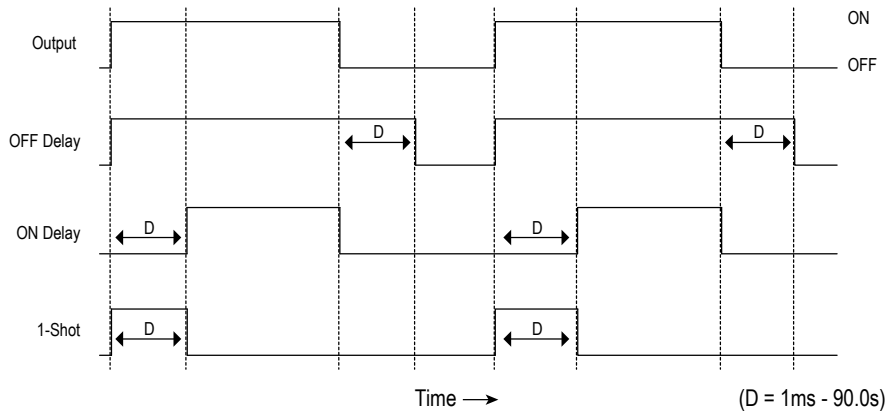

When one of the timing delay options is chosen, the sensor returns to the Setup menu and additional options become available to set the parameter(s):

dLY

- *ond* —On delay
- *ofd* —Off delay

15ha

- *dt1* / *dt2* —One-shot delay timer

**Note:** For the one-shot delay timer:

- LO = On pulse when a target is detected inside of the switch point(s)
- DO = On pulse when a target is detected outside of the switch point(s)

totl

- *dt1* / *dt2* —Output duration
- *tot1* / *tot2* —Number of counts before an output change

Delay Timers *ond1 ond2 ofd2 ofd2 dt1 dt2*

Use these menus to set the delay timers. These menus are available only if an output timing delay is selected.

For *ond* and *ofd*, the default is 0.

For *dt1*, the defaults are:

- 10 milliseconds for 10, 15, 25, and 50 millisecond response speeds
- 1 millisecond for 1.5, 2, 3, and 5 milliseconds response speeds

Use \oplus and \ominus to scroll through the values. Millisecond values do not include the decimal point; seconds values include the decimal point.

- 1 to 999 ms (when *dt1* is selected, the 1 to 9 ms range is available for 1.5, 2, 3, and 5 ms response times)
- 1.0 to 90.0 s

Totalizer *totl*

The totalizer function changes the output only after counting a designated number of targets.

After selecting this function, *dt1* or *dt2* become available to define the output duration and *tot1* or *tot2* to define required number of counts before the output changes.

For *tot1* and *tot2*, the default is 1 count and the maximum is 9999 counts.

For *dt1* and *dt2*, the default is 10 milliseconds. Use \oplus and \ominus to scroll through the values. Values in millisecond do not include the decimal point; values in seconds include the decimal point.

- 1 to 999 ms (when *dt1* or *dt2* is selected, the 1 to 9 ms range is available for 1.5, 2, 3, and 5 ms response times)
- 1.0 to 90.0 s

From Run mode, press **SELECT** to change the display to show the current totalizer count. Pressing **SELECT** again changes the display back to the measured distance.

The totalizer count automatically resets after re-teaching the switch point distance or turning the sensor off.

3.2.9 Zero Reference Location *zero*

Use this menu to select the zero reference location. Changing the zero reference location only affects the readout on the display and does not affect the output.

The default is *near*, 0 = the front of the sensor. This menu is not available in dual (intensity + distance) mode.

near —0 is the front of the sensor and the measurement increases further from the sensor.

far —0 is the maximum range and the measurement increases closer to the sensor.

3.2.10 Shift the Zero Reference Location after a TEACH **SHIFT**

Use this menu to select whether the sensor shifts the zero reference location based on the last TEACH process. The default is **OFF**, 0 = the front of the sensor or the maximum range. This menu is not available in dual (intensity + distance) mode.

- **ON** —Shift the zero reference location to one of the taught positions with each TEACH
- **OFF** —0 = the front of the sensor or the maximum range, depending on the **ZERO** setting

This figure illustrates three examples of how changes to the zero and shift settings affect what distance readout is shown on the display when in 2-pt TEACH mode. Changes to the zero setting affect the direction in which the distance increases.

Figure 18. Example Zero and Shift settings

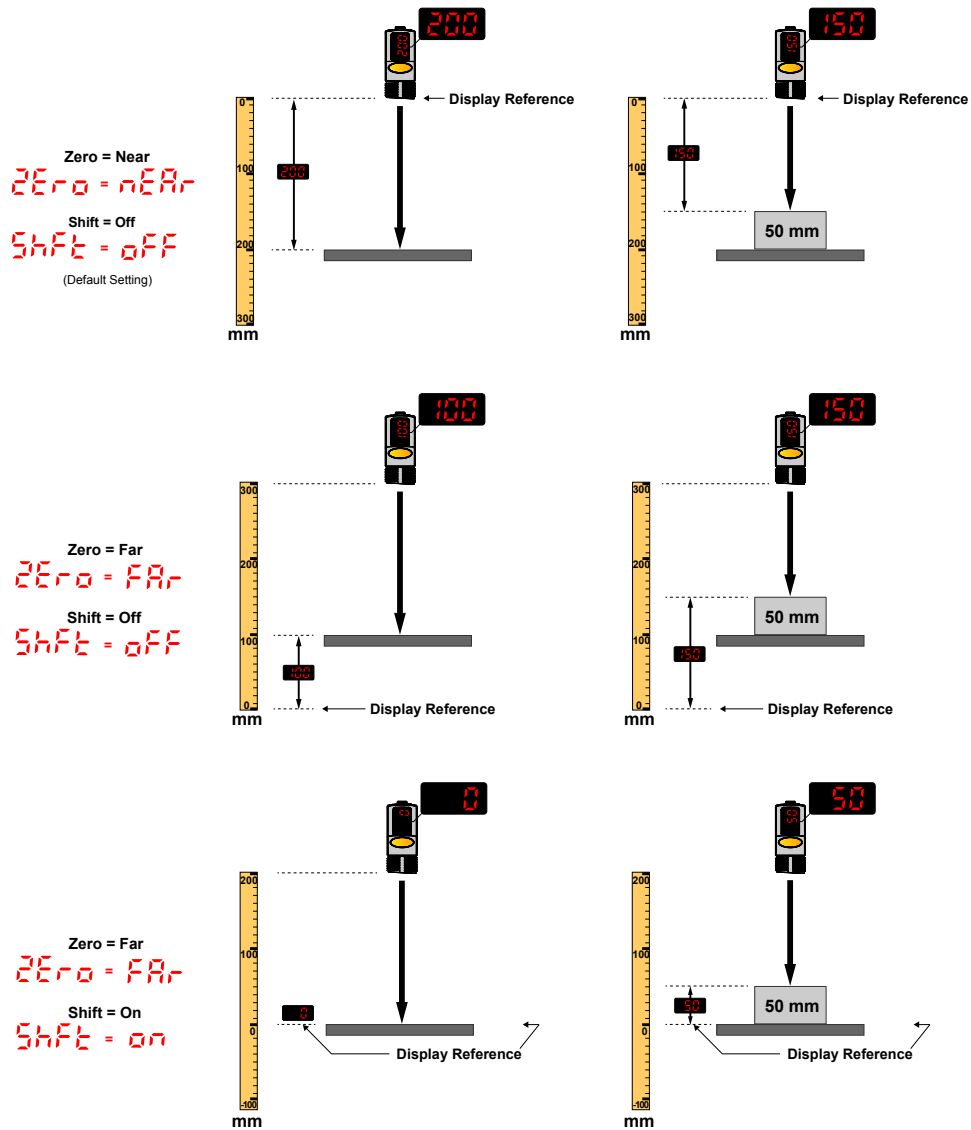

3.2.11 Offset **oFS1** **oFS2**

Use this menu to set an offset from the taught surface. This menu is available only if one-point window (foreground suppression) mode or one-point background suppression mode is selected. For Channel 2, the output must be set to light operate or dark operate.



Note: The number that follows **oFS** on the display indicates which channel is selected.

The offset is automatically calculated or manually defined as a consistently applied value. **Auto** is the default option. Use +/- to select a value. Values increase or decrease by 0.1 mm (100/110 mm models) or 0.2 mm (300/310/600/610 mm models).

For BGS mode, the default is **Auto** because the Q4X automatically selects where to position the switch point. For FGS mode, the default is 0 because the window is centered around the taught target.

A positive offset value always shifts the switch point location or the FGS window towards the sensor.

The taught surface must be inside of the defined sensing range. When the teach mode is set to FGS, some portion of the window must be located within the sensing range. When the teach mode is set to BGS, the offset value must be within the defined sensing range. If an offset value falls outside of the sensing range, a message displays. See the applicable TEACH procedure for more information.

3.2.12 Display View *d.5P*

Use this menu to select the display view.

When the sensor is in sleep mode, the display wakes with the first button press.

1234 —Normal (default setting)

4E21 —Inverted (rotated 180°)

oFF —Normal and the display enters sleep mode after 60 seconds

33° —Inverted (rotated 180°) and the display enters sleep mode after 60 seconds

3.2.13 Exit Setup Mode *End*

Use this menu to end Setup mode.

Navigate to *End* and press **SELECT** to exit Setup mode and return to Run mode.

3.2.14 Reset to Factory Defaults *r5Et*

Use this menu to restore the sensor to the factory default settings.

no —Select to return to the sensor menu without restoring the defaults.

YES —Select to apply the factory defaults and return to Run mode.

Factory Default Settings

Setting	Factory Default
Delay Timers (<i>dLY</i>)	<i>oFF</i> —No delay
Display View (<i>d.5P</i>)	<i>1234</i> —Normal, no sleep mode
Gain and Sensitivity (<i>GA.in</i>)	<i>HIGH</i> —High excess gain mode
Output (<i>out1, out2</i>)	<i>L0</i> —Light Operate
Response Speed (<i>SPd</i>)	<i>10</i> —10 ms for 100/110 and 300/310 models <i>25</i> —25 ms for 600/610 models
Shift the Zero Reference Location after a TEACH (<i>SHft</i>)	<i>oFF</i> —0 = the front of the sensor
TEACH Mode (<i>tch</i>)	<i>2-pt</i> —Two-point TEACH
Zero Reference Location (<i>ZEro</i>)	<i>nEAR</i> —Measurement increases further from sensor

3.3 Manual Adjustments

Manually adjust the sensor switch point using the \oplus and \ominus buttons.

1. From Run mode, press either \oplus or \ominus one time. The selected channel displays briefly, then the current switch point value flashes slowly.
2. Press \oplus to move the switch point up or \ominus to move the switch point down. After 1 second of inactivity, the new switch point value flashes rapidly, the new setting is accepted, and the sensor returns to Run mode.



Note: When FGS mode is selected (FGS indicator is on), manual adjustment moves both sides of the symmetrical threshold window simultaneously, expanding and collapsing the window size. Manual adjustment does not move the center point of the window.



Note: When dual mode is selected (DYN, FGS, and BGS indicators are on), after the TEACH process is completed, use the manual adjustment to adjust the sensitivity of the thresholds around the taught reference point. The taught reference point is a combination of the measured distance and returned signal intensity from the reference target. Manual adjustment does not move the taught reference point, but pressing \oplus increases the sensitivity, and pressing \ominus decreases the sensitivity. When re-positioning the sensor or changing the reference target, re-teach the sensor.

3.4 Remote Input

Use the remote input to program the sensor remotely.

Remote input is available from the Channel 2 menu. Set **Out2** to **Set**.

The remote input provides limited programming options and is Active high.

For Active high, connect the white input wire to 24 V DC, with a remote switch connected between the wire and ground.

Pulse the remote input according to the diagram and the instructions provided in this manual.

The length of the individual programming pulses is equal to the value **T**: **0.04 seconds \leq T \leq 0.8 seconds**.

Exit remote programming modes by setting the remote input high for longer than 2 seconds.

Figure 19. Remote Input Map

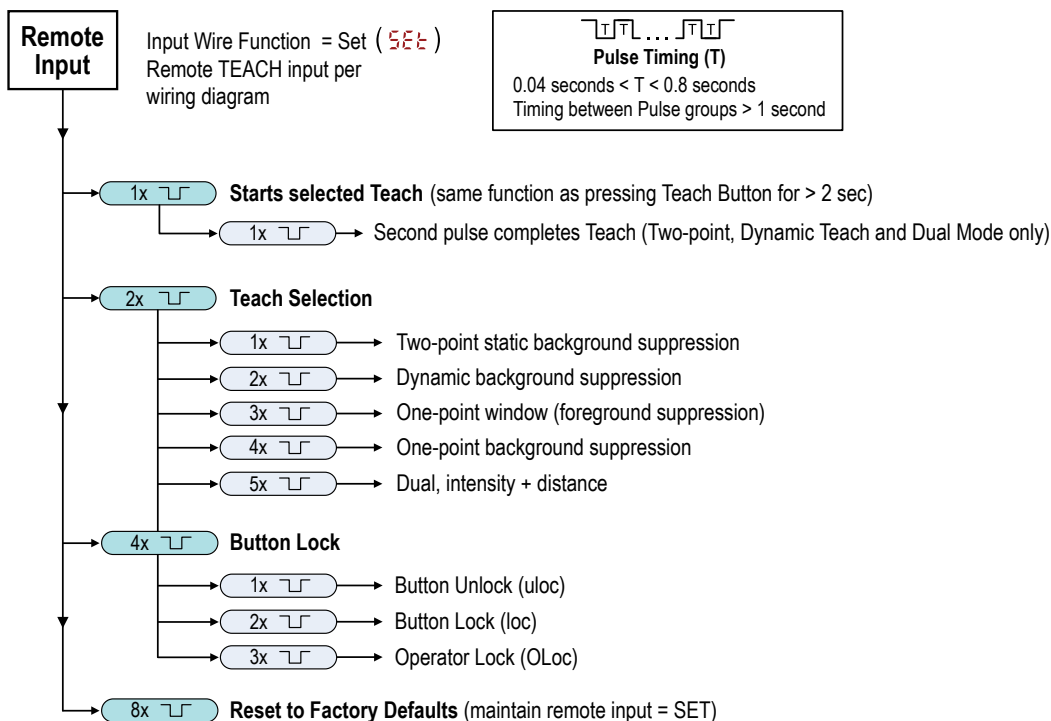

3.4.1 Select the TEACH Mode Using the Remote Input

Follow the instructions below to choose a specific TEACH Mode using Remote Input.

1. Access the TEACH selection.

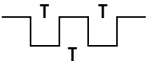
Action	Result
Double-pulse the remote input. 	teach displays.

2. Select the desired TEACH mode.

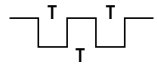
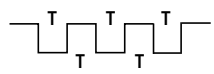
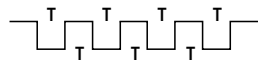
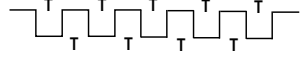
Action		Result
Pulses	TEACH Mode	
1 	Two-point static background suppression	The selected TEACH method displays for a few seconds and the sensor returns to Run mode.
2 	Dynamic background suppression	
3 	One-point window (foreground suppression)	
4 	One-point background suppression	
5 	Dual (intensity + distance)	

3.4.2 Reset to Factory Defaults Using the Remote Input

Follow the instructions below to reset the Q4X to factory defaults using Remote Input.

Eight-pulse the remote input to apply the factory defaults and return to Run mode.



Note: The input wire function remains at remote teach input (**SET**).

3.5 Locking and Unlocking the Sensor Buttons

Use the lock and unlock feature to prevent unauthorized or accidental programming changes.

Three settings are available:

- **wLoc** —The sensor is unlocked and all settings can be modified (default).
- **Loc** — The sensor is locked and no changes can be made.
- **OLoc** —The switch point value can be changed by teaching or manual adjustment, but no sensor settings can be changed through the menu.



Note: When the sensor is in either **Loc** or **OLoc** mode, the active channel can be changed using (+) (**CH1/CH2**).

When in **Loc** mode, **Loc** displays when the (**SELECT**)(**TEACH**) button is pressed. The switch point displays when (+) (**CH1/CH2**) or (-)(**MODE**) are pressed, but **Loc** displays if the buttons are pressed and held.

When in **OLoc** mode, **Loc** displays when (-)(**MODE**) is pressed and held. To access the manual adjust options, briefly press and release (+)(**CH1/CH2**) or (-)(**MODE**). To enter TEACH mode, press the (**SELECT**)(**TEACH**) button and hold for longer than 2 seconds.

Button Instructions

To enter **Loc** mode, hold **+** and press **-** four times. To enter **OLoc** mode, hold **+** and press **-** seven times. Holding **+** and pressing **-** four times unlocks the sensor from either lock mode and the sensor displays **wLoc**.

Remote Input Instructions

1. Access the remote input.

Action	Result
Four-pulse the remote input.	The sensor is ready to have the button state defined and btn displays.

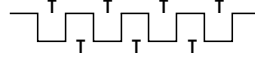

2. Lock or unlock the sensor buttons.

Action	Result
Single-pulse the remote input to unlock the sensor.	wLoc displays and the sensor returns to Run mode.
Double-pulse the remote input to lock the sensor.	Loc displays and the sensor returns to Run mode.
Triple-pulse the remote input to apply the operator lock to the sensor	OLoc displays and the sensor returns to Run mode

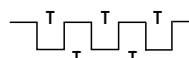
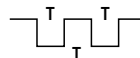
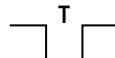

3.6 TEACH Procedures

Use the following procedures to teach the sensor.

To cancel a TEACH procedure, press **TEACH** for longer than 2 seconds, or hold the remote input high for longer than 2 seconds. **ENCL** momentarily displays when a TEACH procedure is canceled.

After any teach operation starts, the display temporarily flashes CH1 or CH2 to confirm which channel is currently selected.

3.6.1 Two-Point Static Background Suppression **2-Pt**

Two-point TEACH sets a single switch point. The sensor sets the switch point between two taught target distances, relative to the shifted origin location.

Figure 20. Two-Point Static Background Suppression (Light Operate shown)

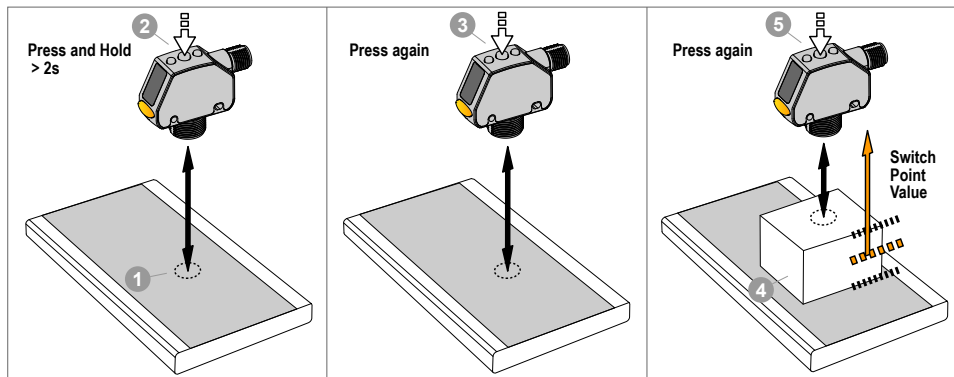

Note: The sensor must be set to **teach = 2-Pt** to use the following instructions.



Note: To program the sensor using remote input, remote input must be enabled (**out2 = Set**).

1. Present the target.

Method	Action	Result
Push Button	Present the first target. The sensor-to-target distance must be within the sensor's range.	The target's measurement value displays.
Remote Input		

2. Start the TEACH mode.

Method	Action	Result
Push Button	Press and hold TEACH for longer than 2 seconds.	SET and 1st flash alternately on the display. The DYN, FGS, and BGS indicators flash.
Remote Input	No action required.	N/A

3. Teach the sensor.

Method	Action	Result
Push Button	Press TEACH to teach the target.	The sensor is taught the first target. SET , 2nd , and the current distance measurement flash alternately on the display. The DYN, FGS, and BGS indicators flash.
Remote Input	Single-pulse the remote input. 	

4. Present the target.

Method	Action	Result
Push Button	Present the second target. The sensor-to-target distance must be within the sensor's range.	SET , 2nd , and the distance measurement flash alternately on the display. The DYN, FGS, and BGS indicators flash.
Remote Input		

5. Teach the sensor.

Method	Action	Result
Push Button	Press TEACH to teach the target.	The new switch point flashes rapidly and the sensor returns to Run mode.
Remote Input	Single-pulse the remote input. 	

Table 3: Expected TEACH Behavior for Two-Point Static Background Suppression

See Figure 26 on page 36 for the minimum object separation.

Condition	TEACH Result	Display
Two valid distances that are greater than or equal to the horizontal minimum object separation	Sets a switch point between the two taught distances.	The switch point distance flashes on the display.
Two valid distances that are less than the horizontal minimum object separation	Sets a switch point in front of the furthest taught distance by the horizontal minimum object separation.	BGS and the switch point distance flash alternately on the display.
One valid distance with one invalid TEACH point	Sets a switch point between the one taught distance and the maximum range.	OBJT and the switch point distance flash alternately on the display.
Two invalid TEACH points	Sets a switch point at the location given in Table 4 on page 21.	FULL and the switch point distance flash alternately on the display.

Table 4: Switch Point Location

Model	Switch Point
100 mm threaded barrel models	99
300 mm threaded barrel models	290

Model	Switch Point
600 mm threaded barrel models	590
110 mm flush mount models	109
310 mm flush mount models	300
610 mm flush mount models	600

3.6.2 Dynamic Background Suppression *dyn*

Dynamic TEACH sets a single switch point during machine run conditions. Dynamic TEACH is recommended for applications where a machine or process may not be stopped for teaching. The sensor takes multiple samples and the switch point is set between the minimum and the maximum sampled distances.

Figure 21. Dynamic Background Suppression

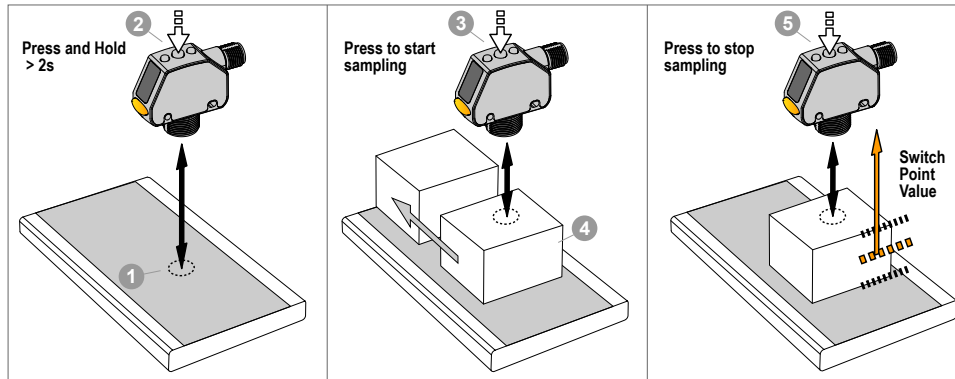

Note: The sensor must be set to *teach = dyn* to use the following instructions. The DYN indicator is amber to indicate Dynamic TEACH mode.

Note: To program the sensor using remote input, remote input must be enabled (*out2 = Set*).

1. Present the target.

Method	Action	Result
Push Button	Present the first target. The sensor-to-target distance must be within the sensor's range.	The target's measurement value displays.
Remote Input		

2. Start the TEACH mode.

Method	Action	Result
Push Button	Press and hold TEACH for longer than 2 seconds.	<i>dyn</i> and <i>Set</i> flash alternately on the display. The DYN indicator flashes.
Remote Input	No action required.	N/A

3. Teach the sensor.

Method	Action	Result
Push Button	Press TEACH to teach the target.	The sensor begins sampling target distance information and <i>dyn</i> and <i>Set</i> flash alternately on the display. The DYN indicator flashes.
Remote Input	Single-pulse the remote input. 	

4. Present the targets.

Method	Action	Result
Push Button	Present additional targets. The sensor-to-target distance must be within the sensor's range.	The sensor continues to sample target distance information and dyn and Stop flash alternately on the display. The DYN indicator flashes.
Remote Input		

5. Teach the sensor.

Method	Action	Result
Push Button	Press TEACH to stop teaching the sensor.	The new switch point flashes rapidly and the sensor returns to Run mode.
Remote Input	Single-pulse the remote input. 	

Table 5: Expected TEACH Behavior for Dynamic Background Suppression

See Figure 26 on page 36 for the minimum object separation.

Condition	TEACH Result	Display
Two valid distances that are greater than or equal to the horizontal minimum object separation	Sets a switch point between the two taught distances.	The switch point distance flashes on the display.
Two valid distances that are less than the horizontal minimum object separation	Sets a switch point in front of the furthest taught distance by the horizontal minimum object separation.	bcs and the switch point distance flash alternately on the display.
One valid distance with one invalid TEACH point	Sets a switch point between the one taught distance and the maximum range.	abut and the switch point distance flash alternately on the display.
Two invalid TEACH points	Sets a switch point at the location given in Table 6 on page 23.	bcs and the switch point distance flash alternately on the display.

Table 6: Switch Point Location

Model	Switch Point
100 mm threaded barrel models	75
300 mm threaded barrel models	200
600 mm threaded barrel models	400
110 mm flush mount models	85
310 mm flush mount models	210
610 mm flush mount models	410

3.6.3 One-Point Window (Foreground Suppression) **FOS**

One-point window sets a window (two switch points) centered around the taught target distance. Loss of signal is treated as a detection in One-Point Window mode. The size of the taught window is the vertical minimum object separation. See Figure 26 on page 36.

Manually adjust the window size from Run mode using **+** and **-**.

Figure 22. One-Point Window (Foreground Suppression)

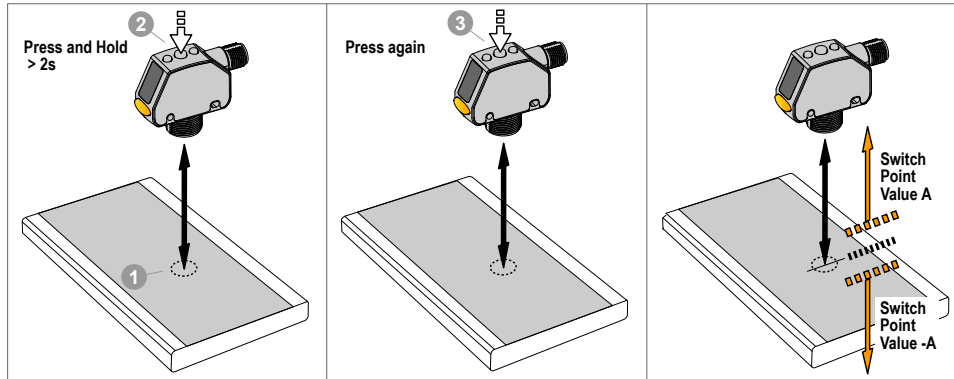

In order to reliably detect changes from the taught background, if multiple laser reflections are returning to the sensor, the output status is treated as though the target is outside of the taught window. The display alternates between `2-Lr` and the measured distance. Realign the laser to avoid light reflecting off of multiple targets if this extra level of verification is not desired.



Note: The sensor must be set to `teach = FGS` to use the following instructions. The FGS indicator is amber to indicate One-Point Window (Foreground Suppression) mode.



Note: To program the sensor using remote input, remote input must be enabled (`out2 = Set`).

1. Present the target.

Method	Action	Result
Push Button Remote Input	Present the target. The sensor-to-target distance must be within the sensor's range.	The target's measurement value displays.

2. Start the TEACH mode.

Method	Action	Result
Push Button Remote Input	Press and hold TEACH for longer than 2 seconds. No action required.	Light Operate <code>Set</code> and <code>on</code> flash alternately on the display. The FGS indicator flashes. Dark Operate <code>Set</code> and <code>off</code> flash alternately on the display. The FGS indicator flashes.

3. Teach the sensor.

Method	Action	Result
Push Button Remote Input	Press TEACH to teach the target. Single-pulse the remote input.	The \pm window size flashes rapidly and the sensor returns to Run mode.



Table 7: Expected TEACH Behavior for One-Point Window (Foreground Suppression)

See Figure 26 on page 36 for the minimum object separation.

Condition	TEACH Result	Display
One valid TEACH point with both switch points in range (with offset, if applicable)	Sets a window (two switch points) centered around the taught distance. The \pm window size is the vertical minimum object separation. The two switch points always stay within the specified sensing range.	The \pm window size flashes on the display.
One invalid TEACH Point	Sets a window (two switch points) centered around the location given in Table 8 on page 25. The window size is given in Table 9 on page 25.	---- and the window center point distance flash alternately on the display.
One valid TEACH point with one switch point within range and one switch point out of range (with offset, if applicable)	Sets a window (two switch points) that is centered at the TEACH point (after offset, if applicable) with one switch point at the maximum range.	---- and the \pm window size flash alternately on the display.
One valid TEACH point that, after the offset, results in a both switch points outside of the range	Sets a window (two switch points) centered around the location given in Table 10 on page 25. The window size is given in Table 11 on page 25.	offst and the window center point distance flash alternately on the display.

Table 8: Window Center Point

Model	Window Center Point
100 mm threaded barrel models	80
300 mm threaded barrel models	250
600 mm threaded barrel models	500
110 mm flush mount models	90
310 mm flush mount models	260
610 mm flush mount models	510

Table 9: Window Size

Model	Window Size
100 mm threaded barrel and 110 mm flush mount models	± 12.5 mm
300 mm threaded barrel and 310 mm flush mount models	± 25 mm
600 mm threaded barrel and 610 mm flush mount models	± 25 mm

Table 10: Window Center Point When Switch Points are Out of Range

Model	Window Center Point
100 mm threaded barrel models	80
300 mm threaded barrel models	250
600 mm threaded barrel models	500
110 mm flush mount models	90
310 mm flush mount models	260
610 mm flush mount models	510

Table 11: Window Size When Switch Points are Out of Range

Model	Window Size
100 mm threaded barrel and 110 mm flush mount models	± 12.5 mm
300 mm threaded barrel and 310 mm flush mount models	± 25 mm

Model	Window Size
600 mm threaded barrel and 610 mm flush mount models	± 25 mm

3.6.4 One-Point Background Suppression b05

One-point background suppression sets a single switch point in front of the taught target distance. Objects beyond the taught switch point are ignored. The switch point is set in front of the taught target distance by the vertical minimum object separation. See [Figure 26](#) on page 36.

Figure 23. One-Point Background Suppression

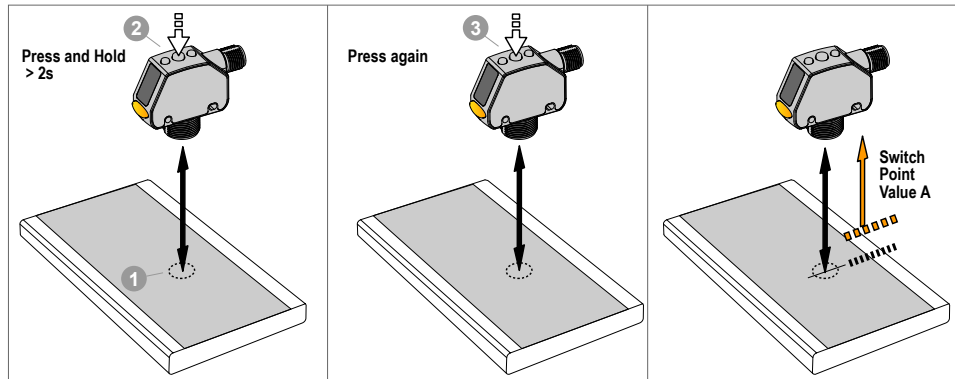

Note: The sensor must be set to bch = b05 to use the following instructions. The BGS indicator is amber to indicate Background Suppression mode.

Note: To program the sensor using remote input, remote input must be enabled (out2 = 5Et).

1. Present the target.

Method	Action	Result
Push Button	Present the target. The sensor-to-target distance must be within the sensor's range.	The target's measurement value displays.
Remote Input		

2. Start the TEACH mode.

Method	Action	Result
Push Button	Press and hold TEACH for longer than 2 seconds.	<p>Light Operate</p> <p>5Et and off flash alternately on the display. The BGS indicator flashes.</p> <p>Dark Operate</p> <p>5Et and on flash alternately on the display. The BGS indicator flashes.</p>
Remote Input	No action required.	N/A

3. Teach the sensor.

Method	Action	Result
Push Button	Press TEACH to teach the target.	The new switch point flashes rapidly and the sensor returns to Run mode.
Remote Input	Single-pulse the remote input. 	

Table 12: Expected TEACH Behavior for One-Point Background Suppression

See [Figure 26](#) on page 36 for the minimum object separation.

Condition	TEACH Result	Display
One valid TEACH point If an Offset is applied, the TEACH point is still valid	Sets a switch point in front of the taught distance by the vertical minimum object separation.	The switch point distance flashes on the display.
One invalid TEACH point	Sets a switch point at the location given in Table 13 on page 27.	bGS and the switch point distance flash alternately on the display.
One valid TEACH point that, after offset, becomes invalid	Sets a switch point at the location given in Table 14 on page 27.	oFSt and the switch point distance flash alternately on the display.

Table 13: Switch Point Location

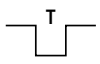
Model	Switch Point
100 mm threaded barrel models	75
300 mm threaded barrel models	200
600 mm threaded barrel models	400
110 mm flush mount models	85
310 mm flush mount models	210
610 mm flush mount models	410

Table 14: Switch Point Location after One TEACH Point Becomes Invalid

Model	Switch Point
100 mm threaded barrel models	75
300 mm threaded barrel models	200
600 mm threaded barrel models	400
110 mm flush mount models	85
310 mm flush mount models	210
610 mm flush mount models	410

3.6.5 Dual (Intensity + Distance) **dUAL**

Dual (intensity + distance) TEACH records the distance and amount of light received from the reference surface. The output switches when an object passing between the sensor and the reference surface changes the perceived distance or amount of returned light. For more information on dual TEACH mode, see [Dual \(Intensity + Distance\) Mode](#) on page 38.



Note: To use the following instructions, set the sensor to **teCh = dUAL**. The DYN, FGS, and BGS indicators are amber.



Note: To program the sensor using remote input, remote input must be enabled (**out2 = 5Et**).

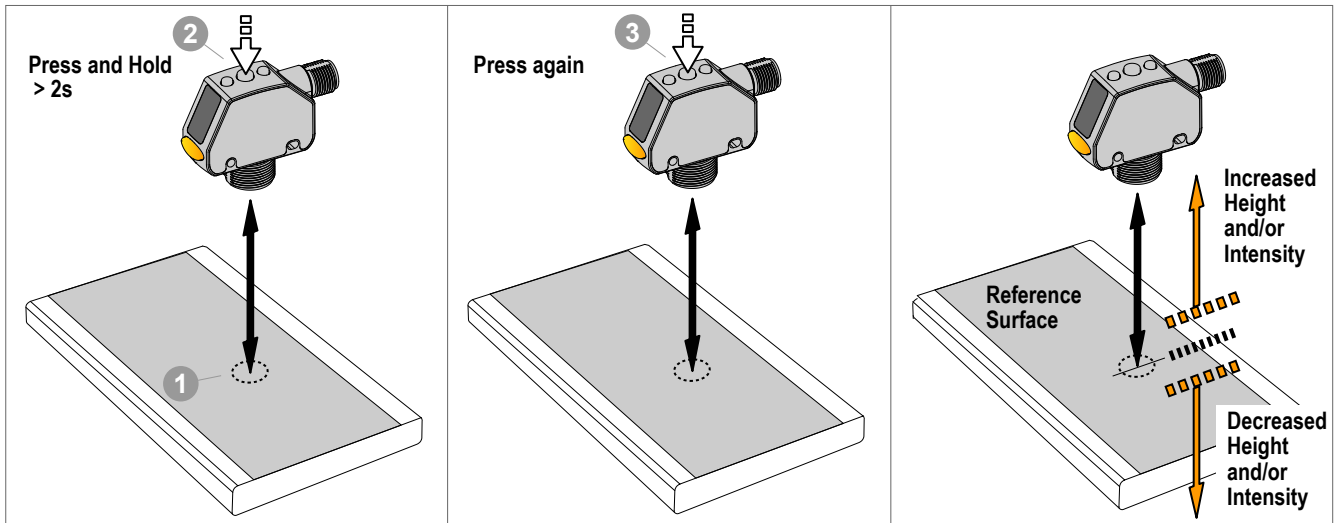

1. Present the target.

Method	Action	Result
Push Button Remote Input	Present the reference target.	The target's match percentage displays

2. Start the TEACH mode.

Method	Action	Result
Push Button	Press and hold the TEACH button for more than 2 seconds.	Light Operate: SET and on flash on the display. The DYN, FGS, and BGS indicators flash. Dark Operate: SET and off flash on the display. The DYN, FGS, and BGS indicators flash.
Remote Input	No action required.	N/A

3. Teach the sensor.

Method	Action	Result
Push Button	Press the TEACH button.	The switching threshold flashes rapidly and the sensor returns to Run mode.
Remote Input	Single-pulse the remote input. 	

Table 15: Expected TEACH Behavior for Dual (Intensity + Distance) Mode

Condition	TEACH Result	Display
One valid reference surface is taught within sensing range	Sets a dual (intensity + distance) window centered around the taught reference surface. The \pm window size is the previously used switching threshold, or 75% by default.	The switching threshold flashes on the display.
One reference surface is taught outside the sensing range	Sets a dual (intensity + distance) window centered around the taught reference surface that is outside the sensing range. The sensing conditions may not be as reliable.	out flashes on the display.
One invalid TEACH Point	No reference surface is taught, the output will change when any object is detected.	FULL flashes on the display.

3.7 Pulse Frequency Modulation (PFM) Output **PUL5**

The Q4X can generate pulses whose frequency are proportional to the sensor's measured distance, thereby providing a method for representing an analog signal with only a discrete counter.

The sensing range of the sensor is scaled from 100 Hz to 600 Hz (100 Hz equals the near range limit of the sensor, 600 Hz equals the far sensing range limit). An output of 50 Hz represents a Loss of Signal (**LOS**) condition where there is no target or the target is out of the sensor's range. There is a 2 second delay before the sensor sets the output to 50 Hz to indicate loss of signal. During the 2 seconds, the output will hold the last PFM value. To find the Pulse Frequency Modulation (PFM) Output, set **out2** to **PUL5**.

3.8 Sync Master/Slave

Two Q4X sensors may be used together in a single sensing application.

To eliminate crosstalk between the two sensors, configure one sensor to be the master and one to be the slave. In this mode, the sensors alternate taking measurements and the response speed doubles.



Important: The master sensor and the slave sensor must be programmed for the same Response Speed and Gain and Sensitivity settings. The master sensor and slave sensor must share a common power source.

1. Configure the first sensor as the master; navigate: **out2** > **MAST** .
2. Configure the second sensor as the slave; navigate: **out2** > **SLAVE** .
3. Connect the white wires of the two sensors together.

4 IO-Link Interface

IO-Link is a point-to-point communication link between a master device and sensor. Use IO-Link to parameterize sensors and transmit process data automatically.

For the latest IO-Link protocol and specifications, see www.io-link.com.

Each IO-Link device has an IODD (IO Device Description) file that contains information about the manufacturer, article number, functionality etc. This information can be easily read and processed by the user. Each device can be unambiguously identified via the IODD as well as via an internal device ID. Download the Q4X's IO-Link IODD package (p/n 196929) from Banner Engineering's website at www.bannerengineering.com.

Banner has also developed Add On Instruction (AOI) files to simplify ease-of-use between the Q4X, multiple third-party vendors' IO-Link masters, and the Logix Designer software package for Rockwell Automation PLCs. Three types of AOI files for Rockwell Allen-Bradley PLCs are listed below. These files and more information can be found at www.bannerengineering.com.

Process Data AOIs—These files can be used alone, without the need for any other IO-Link AOIs. The job of a Process Data AOI is to intelligently parse out the Process Data word(s) in separate pieces of information. All that is required to make use of this AOI is an EtherNet/IP connection to the IO-Link Master and knowledge of where the Process Data registers are located for each port.

Parameter Data AOIs—These files require the use of an associated IO-Link Master AOI. The job of a Parameter Data AOI, when working in conjunction with the IO-Link Master AOI, is to provide quasi-realtime read/write access to all IO-Link parameter data in the sensor. Each Parameter Data AOI is specific to a given sensor or device.

IO-Link Master AOIs—These files require the use of one or more associated Parameter Data AOIs. The job of an IO-Link Master AOI is to translate the desired IO-Link read/write requests, made by the Parameter Data AOI, into the format a specific IO-Link Master requires. Each IO-Link Master AOI is customized for a given brand of IO-Link Master.

Add and configure the relevant Banner IO-Link Master AOI in your ladder logic program first; then add and configure Banner IO-Link Device AOIs as desired, linking them to the Master AOI as shown in the relevant AOI documentation.

5 Specifications

Sensing Beam

Visible red Class 1 laser, 655 nm

Supply Voltage (Vcc)

10 V DC to 30 V DC (Class 2 supply) (10% max ripple within limits)

Power and Current Consumption, exclusive of load

< 700 mW

Sensing Range—Threaded Barrel Models

600 mm models: 25 mm to 600 mm (0.98 in to 23.62 in)

300 mm models: 25 mm to 300 mm (0.98 in to 11.81 in)

100 mm models: 25 mm to 100 mm (0.98 in to 3.94 in)

Sensing Range—Flush Mount Models

610 mm models: 35 mm to 610 mm (1.38 in to 24.02 in)

310 mm models: 35 mm to 310 mm (1.38 in to 12.20 in)

110 mm models: 35 mm to 110 mm (1.38 in to 4.33 in)

Output Configuration

First output = IO-Link, Push/pull

Secondary output = PNP only output or input, or pulse frequency modulated output

Output Rating

100 mA max capability each output

100 mA max total load current for sensor

Saturation: < 2 V

Off-state leakage current: < 50 μ A PNP at 30 V (N.A. push/pull)

Remote Input

Allowable Input Voltage Range: 0 to Vcc

Active High (internal weak pulldown): High state > (VCC - 2 V) @ 1.5 mA max.

Supply Protection Circuitry

Protected against reverse polarity and transient overvoltages

Response Speed

User selectable, 100, 110, 300, and 310 mm models:

- **15** —1.5 milliseconds
- **3** —3 milliseconds
- **10** —10 milliseconds
- **25** —25 milliseconds
- **50** —50 milliseconds

User selectable, 600 and 610 mm models:

- **2** —2 milliseconds
- **5** —5 milliseconds
- **15** —15 milliseconds
- **25** —25 milliseconds
- **50** —50 milliseconds

IO-Link Interface

Supports Smart Sensor Profile: Yes

Baud Rate: 38400 bps

Process Data Widths: 16 bits

IODD files: Provides all programming options of the display, plus additional functionality.

Delay at Power Up

100, 110, 300, 310 mm models: < 750 ms

600, 610 mm models: < 1.5 s

Maximum Torque

Side mounting: 1 N·m (9 in·lbs)

Nose mounting: 20 N·m (177 in·lbs)

Ambient Light Immunity

> 5,000 lux at 300 mm

> 2,000 lux at 600 mm

Connector

Integral 4-pin M12 male quick-disconnect connector

Construction

Housing: 316 L stainless steel

Lens cover: PMMA acrylic

Lightpipe and display window: polysulfone

Temperature Effect

0.05 mm/°C at < 125 mm (threaded barrel models)/< 135 mm (flush mount models)

0.35 mm/°C at 300 mm (threaded barrel models)/310 mm (flush mount models)

1.0 mm/°C at 600 mm (threaded barrel models)/610 mm (flush mount models)

Chemical Compatibility

Compatible with commonly used acidic or caustic cleaning and disinfecting chemicals used in equipment cleaning and sanitation. ECOLAB® certified.

Compatible with typical cutting fluids and lubricating fluids used in machining centers

Application Note

For optimum performance, allow 10 minutes for the sensor to warm up

Environmental Rating

IP67 per IEC60529

IP68 per IEC60529

IP69K per DIN 40050-9

IP rating is dependent on proper cordset installation.

Operating Conditions

-10 °C to +50 °C (+14 °F to +122 °F)

35% to 95% relative humidity

Storage Temperature

-25 °C to +75 °C (-13 °F to +167 °F)

Vibration

MIL-STD-202G, Method 201A (Vibration: 10 Hz to 60 Hz, 0.06 inch (1.52 mm) double amplitude, 2 hours each along X, Y and Z axes), with device operating

Shock

MIL-STD-202G, Method 213B, Condition I (100G 6x along X, Y, and Z axes, 18 shocks), with device operating

Discrete Output Distance Repeatability

Table 16: 100/110 mm Models

Distance (mm)		Repeatability
Threaded Barrel Models	Flush Mount Models	
25 to 100 mm	35 to 110 mm	+/-0.2 mm

Table 17: 300/310 mm Models

Distance (mm)		Repeatability
Threaded Barrel Models	Flush Mount Models	
25 to 50 mm	35 to 60 mm	± 0.5 mm
50 to 300 mm	60 to 310 mm	± 1% of range

Table 18: 600/610 mm Models

Distance (mm)		Repeatability
Threaded Barrel Models	Flush Mount Models	
25 to 100 mm	35 to 110 mm	± 0.5 mm
100 to 600 mm	110 to 610 mm	± 0.5%

Beam Spot Size—100/110 mm Models

Table 19: Beam Spot Size—100/110 mm Models

Distance (mm)		Size (Horizontal × Vertical)
Threaded Barrel Models	Flush Mount Models	
25	35	2.4 mm × 1.0 mm
50	60	2.2 mm × 0.9 mm
100	110	1.8 mm × 0.7 mm

Beam Spot Size—300/310 mm and 600/610 mm Models

Table 20: Beam Spot Size—300/310 mm and 600/610 mm Models

Distance (mm)		Size (Horizontal × Vertical)
Threaded Barrel Models	Flush Mount Models	
25	35	2.6 mm × 1.0 mm
150	160	2.3 mm × 0.9 mm
300	310	2.0 mm × 0.8 mm
600	610	1.9 mm × 1.0 mm

Excess Gain using a 90% White Card—100/110/300/310 mm Models

Table 21: **HIGH** Excess Gain (**Std** Excess Gain ²)

Response Speed (ms)	· at 25 mm (100/300 mm models) · at 35 mm (110/310 mm models)	· at 100 mm (100/300 mm models) · at 110 mm (110/310 mm models)	· at 300 mm (100/300 mm models) · at 310 mm (110/310 mm models)
1.5	200	100	20
3	200	100	20
10	1000 (500)	500 (250)	100 (50)
25	2500 (1000)	1250 (500)	250 (100)
50	5000 (2500)	2500 (1250)	500 (250)

²

- **Std** excess gain available in 10 ms, 25 ms, and 50 ms response speeds only
- **Std** excess gain provides increased noise immunity

Excess Gain using a 90% White Card—600/610 mm Models

Table 22: *HIGH* Excess Gain (*Std* Excess Gain ³)

Response Speed (ms)	· at 25 mm (600 mm models)	· at 100 mm (600 mm models)	· at 300 mm (600 mm models)	· at 600 mm (600 mm models)
	· at 35 mm (610 mm models)	· at 110 mm (610 mm models)	· at 310 mm (610 mm models)	· at 610 mm (610 mm models)
2	280	110	25	6
5	280	110	25	6
15	1000 (360)	400 (150)	80 (30)	20 (7)
25	2000 (1000)	800 (400)	160 (80)	40 (20)
50	4000 (2000)	1600 (800)	320 (160)	80 (40)

Required Overcurrent Protection



WARNING: Electrical connections must be made by qualified personnel in accordance with local and national electrical codes and regulations.

Overcurrent protection is required to be provided by end product application per the supplied table. Overcurrent protection may be provided with external fusing or via Current Limiting, Class 2 Power Supply. Supply wiring leads < 24 AWG shall not be spliced. For additional product support, go to www.bannerengineering.com.

Supply Wiring (AWG)	Required Overcurrent Protection (Amps)
20	5.0
22	3.0
24	2.0
26	1.0
28	0.8
30	0.5

Certifications



Banner Engineering BV Park Lane, Culliganlaan
2F bus 3, 1831 Diegem, BELGIUM



Turck Banner LTD Blenheim House, Blenheim
Court, Wickford, Essex SS11 8YT, Great Britain



Industrial Control Equipment
Class 2 power
UL Environmental Rating: Type 1



chemical compatibility certified

ECOLAB is a registered trademark of Ecolab USA Inc. All rights reserved.



Advanced Capabilities



5.1 FCC Part 15 Class A

This equipment has been tested and found to comply with the limits for a Class A digital device, pursuant to part 15 of the FCC Rules. These limits are designed to provide reasonable protection against harmful interference when the equipment is operated in a commercial environment. This equipment generates, uses, and can radiate radio frequency energy and, if not installed and used in accordance with the instruction manual, may cause harmful interference to radio communications. Operation of this equipment in a residential area is likely to cause harmful interference in which case the user will be required to correct the interference at his own expense.

³

- *Std* excess gain available in 15 ms response speed only
- *Std* excess gain provides increased noise immunity

5.2 Industry Canada

This device complies with CAN ICES-3 (A)/NMB-3(A). Operation is subject to the following two conditions: 1) This device may not cause harmful interference; and 2) This device must accept any interference received, including interference that may cause undesired operation.

Cet appareil est conforme à la norme NMB-3(A). Le fonctionnement est soumis aux deux conditions suivantes : (1) ce dispositif ne peut pas occasionner d'interférences, et (2) il doit tolérer toute interférence, y compris celles susceptibles de provoquer un fonctionnement non souhaité du dispositif.

5.3 Dimensions

All measurements are listed in millimeters [inches], unless noted otherwise.

Figure 24. Threaded Barrel Models

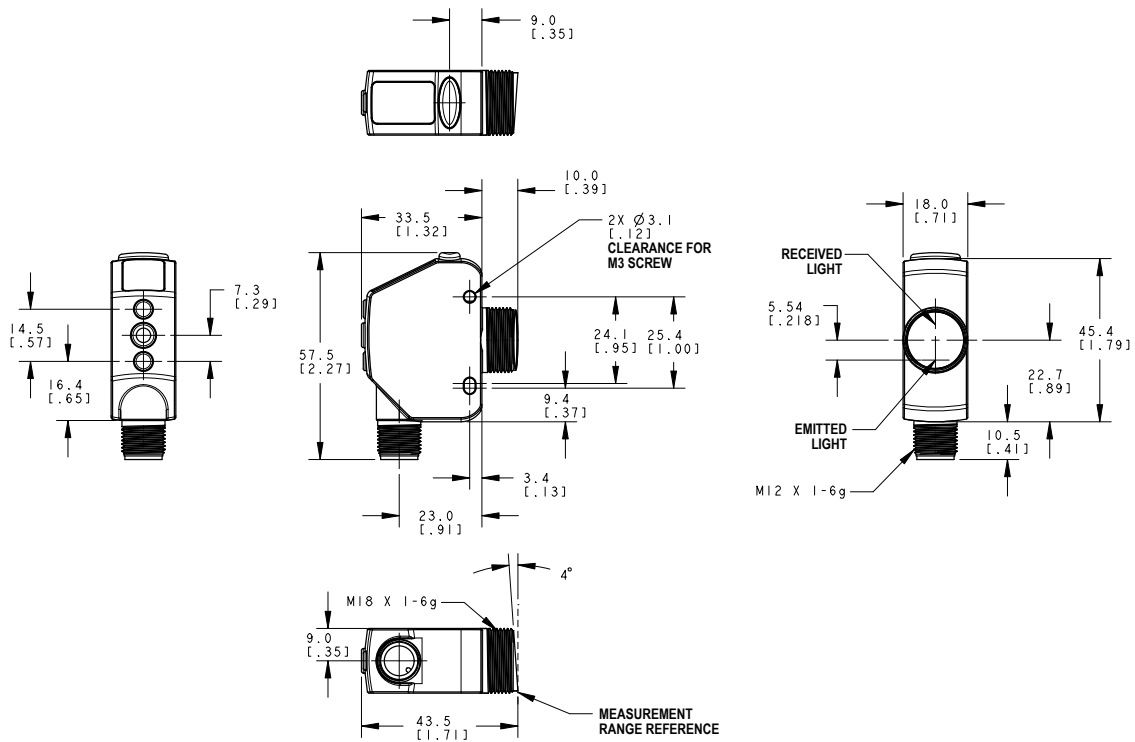
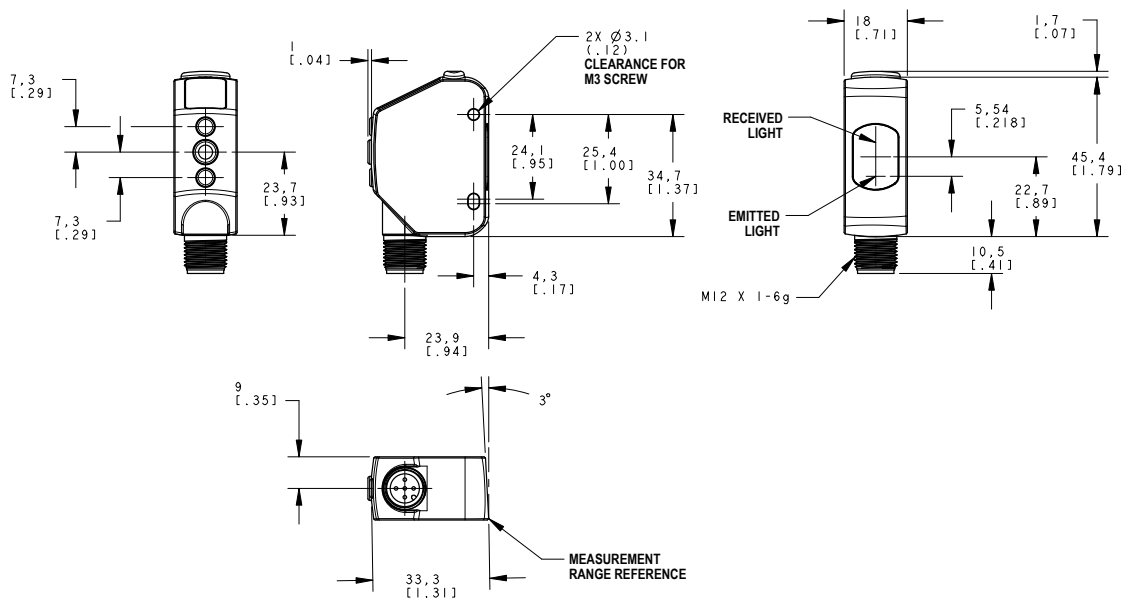

Figure 25. Flush Mount Models



5.4 Performance Curves—Threaded Barrel Models

Figure 26. Minimum Object Separation Distance (90% to 6% reflectance)

Minimum Separation Distance Between Target and Background for: Uniform and Non-Uniform Targets

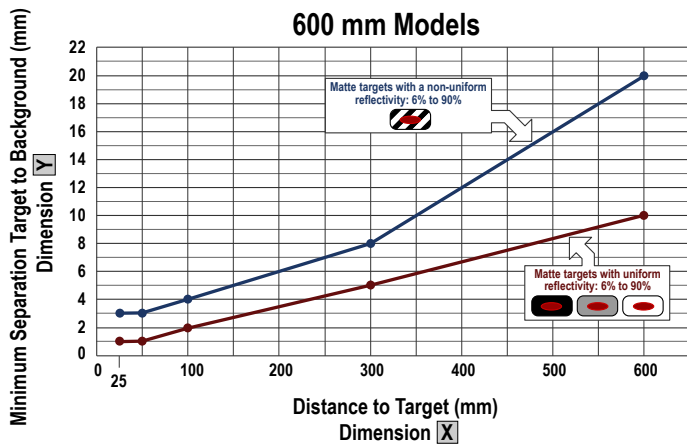
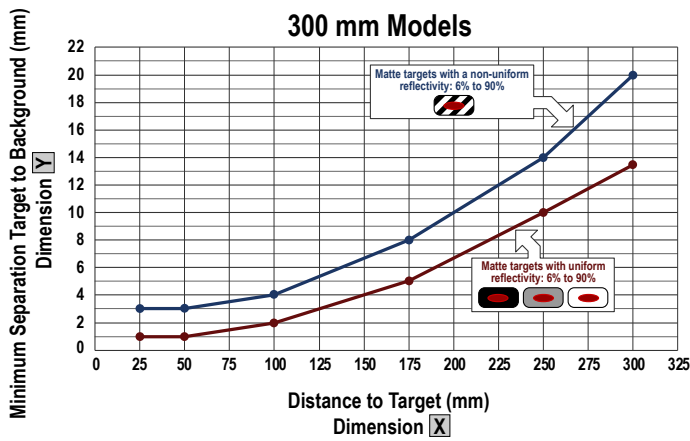
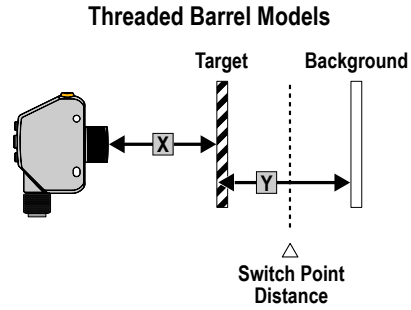
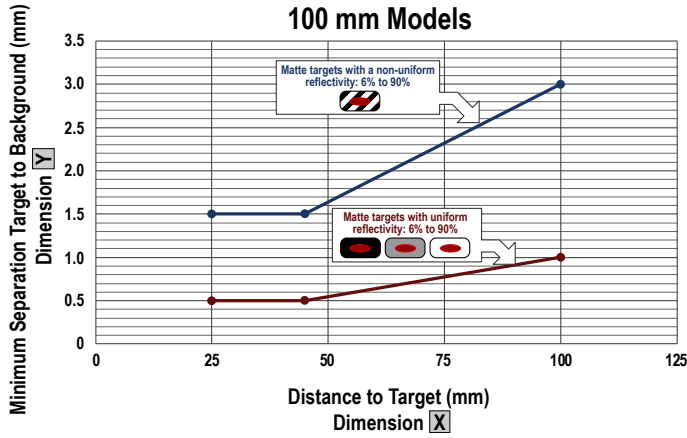

5.5 Performance Curves—Flush Mount Models

Figure 27. Minimum Object Separation Distance (90% to 6% reflectance)

Minimum Separation Distance Between Target and Background for: Uniform and Non-Uniform Targets

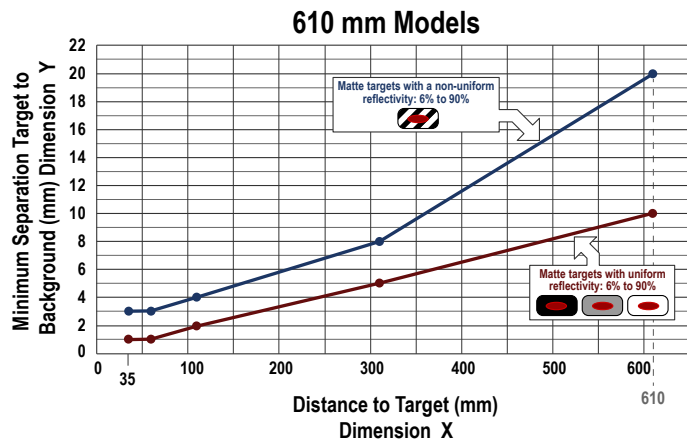
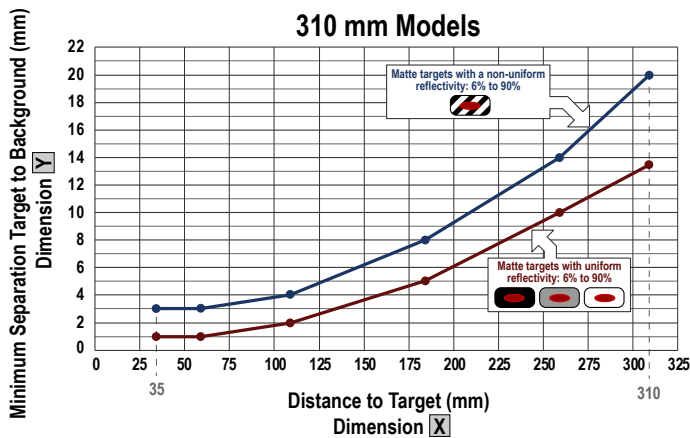
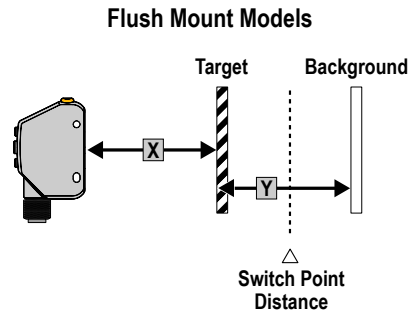
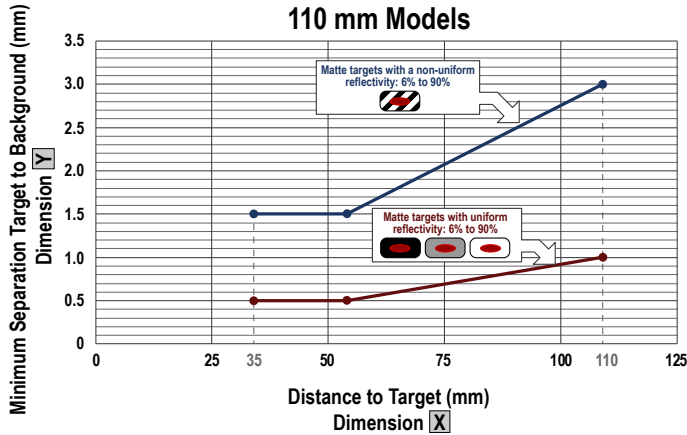

6 Additional Information

6.1 Dual (Intensity + Distance) Mode

In background suppression (DYN, 1-pt, 2-pt) and foreground suppression (FGS) TEACH modes, the Q4X sensor compares changes in the measured distance between the sensor and target to control the output state. Dual TEACH mode, dual intensity + distance window, expands the applications the Q4X can solve by combining distance-based detection with light intensity thresholds. In dual TEACH mode, the user teaches the Q4X a fixed reference surface, and the sensor compares intensity and distance readings against the reference surface it was taught. After teaching the reference target, the displayed value is calibrated to 100P, or a 100% match. When an object enters the sensor's field of view, the degree of consistency with the reference surface becomes lower and causes a change in sensor output.

In dual mode, you can detect when the target is present at the right distance and when it returns the right amount of light. This is useful in error-proofing applications where you need to know not only that the part is present (distance), but also that it is the correct part (intensity).

In dual mode, the Q4X requires a reference surface (far left). Once taught, the distance and intensity of the reference surface are recorded and used as a baseline. A user-adjustable switching threshold is set, and changes in distance and/or intensity outside the switching threshold creates a sensor output change. The example in [Figure 28](#) on page 38 uses a 90% (90P) match condition with a 10% change in intensity and/or distance from the reference surface required to change the output state. The default-switching threshold is a 75% match to the reference condition (75P); this sets the threshold 25% from the distance and intensity of the reference surface. A transparent object can be detected either by a change in intensity, distance, or by a double peak reflection (far right). When a double peak reflection is detected, the display alternates between  and the percent match.

Figure 28. Dual Mode Example



The Q4X sensor can be taught non-ideal reference surfaces, such as surfaces outside of the sensor's range, very dark surfaces, or even empty space. These situations may enable applications requiring a long range detection but are subject to typical diffuse mode detection challenges.

6.2 Dual Mode Reference Surface Considerations

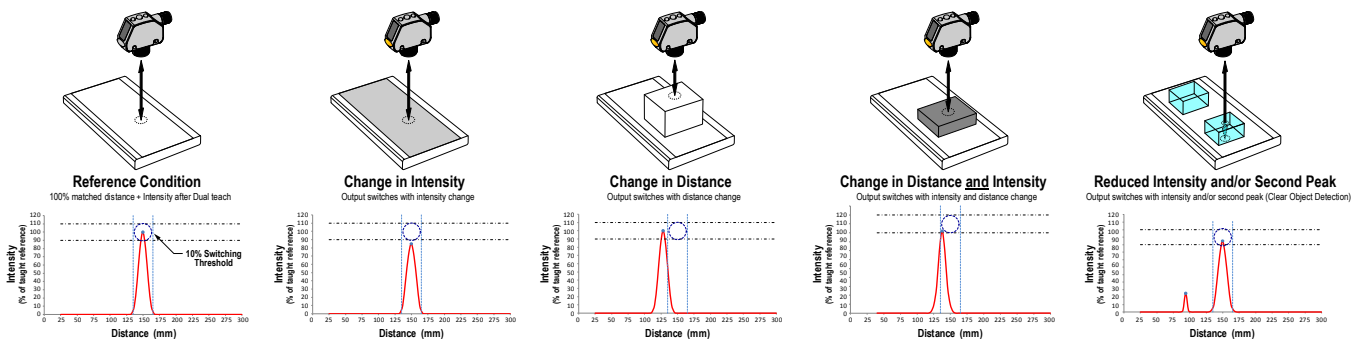
Optimize reliable detection by applying these principals when selecting your reference surface, positioning your sensor relative to the reference surface, and presenting your target.

The robust detection capabilities of the Q4X allows successful detection even under non-ideal conditions in many cases. Typical reference surfaces are metal machine frames, conveyor side rails, or mounted plastic targets. Contact Banner Engineering if you require assistance setting up a stable reference surface in your application.

1. Select a reference surface with these characteristics where possible:
 - Matte or diffuse surface finish
 - Fixed surface with no vibration
 - Dry surface with no build-up of oil, water, or dust
2. Position the reference surface between 50 mm and the maximum sensing range for threaded barrel models or between 60 mm and the maximum sensing range for flush mount models.
3. Position the target to be detected as close to the sensor as possible, and as far away from the reference surface as possible.
4. Angle the sensing beam relative to the target and relative to the reference surface 10 degrees or more.

6.3 Dual Mode Considerations for Clear and Transparent Object Detection

The Q4X is able to detect the very small changes caused by transparent and clear objects. A transparent object can be detected either by a change in intensity, distance, or by a double-peak reflection.

The Q4X sensor can be taught non-ideal reference surfaces, such as surfaces outside of the sensor range or very dark surfaces. Teaching non-ideal reference surfaces may enable applications other than transparent or clear object detection, but best results for transparent or clear object detection require a stable reference surface.

The display shows the match percentage to the taught reference point. The user adjustable switch point defines the sensitivity and the output switches when the match percentage to the reference point crosses the switch point. Your specific application may require fine tuning of the switch point, but these values are the recommended starting values:

Switch point (%)	Typical Applications
75 (default)	Default, recommended for PET bottles and Trays
88	Recommended for thin films
50	Recommended for tinted brown, tinted green, or water-filled containers

Figure 29. Example mounting considerations

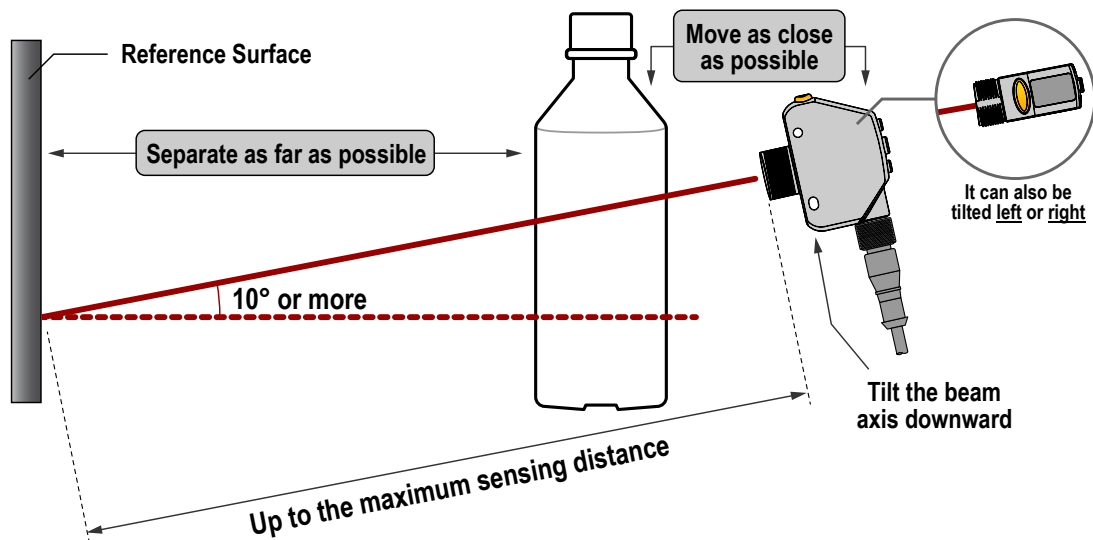
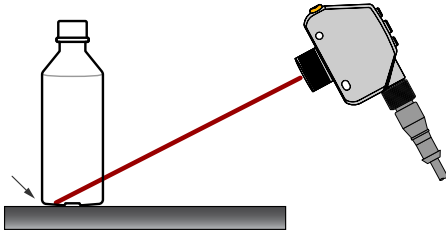

Figure 30. Common problems and solutions for detecting clear objects

PROBLEM:

The object is close to the reference surface



SOLUTION:

Move the target closer to the sensor

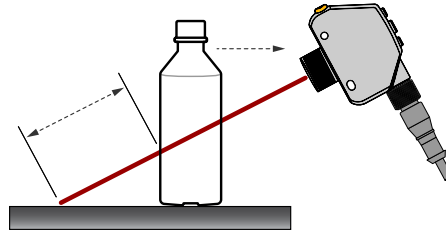

PROBLEM:

The sensor is far from the object

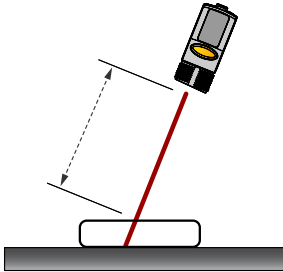

SOLUTION:

Move the sensor closer to the target

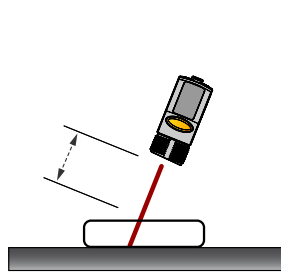

6.4 Abbreviations

The following table describes the abbreviations used on the sensor display and in this manual.

Abbreviation	Description
----	No valid signal in range
9999P	The sensor has not been taught
1Sho	One-shot
1St	First
2-Lr	Multiple light reflections
2nd	Second
2-Plt	Two-point TEACH (static background suppression)
Auto	Automatic
bOS	One-point background suppression
btn	Button
cncl	Cancel
comp	Complementary output
disp	Display read
delay	Delay
delay1, delay2	Output timing delay (Channel 1, Channel 2)

Abbreviation	Description
do	Dark operate
dt1 , dt2	Delay timer (Channel 1, Channel 2)
duRL	Dual mode
dyn	Dynamic background suppression
End	End—exit the sensor menu
FAR	Far zero reference location—the maximum range is 0 and the measurement increase as the target moves closer to the sensor
FOS	One-point window (foreground suppression)
FULL	Full range
GAIN	Excess gain
HIGH	High excess gain mode
HS	High speed tracking
Lo	Light operate
L on	Laser on
Loc	Lock/locked
LoFF	Laser off
MASt	Master
NEAR	Near zero reference location—the front of the sensor is 0 and the measurement increase as the target moves further away from the sensor
objt	Object
oFd1 , oFd2	Off delay timer (Channel 1, Channel 2)
oFF	Off
oFS1 , oFS2	Offset (Channel 1, Channel 2)
oFSt	An applied offset resulted in an invalid switch point
on	On
ond1 , ond2	On delay timer (Channel 1, Channel 2)
out1 , out2	Output (Channel 1, Channel 2)
PULS	Pulse frequency modulation
rSEt	Reset to factory defaults
SAVE	Save
SEt	Set or Input wire = remote teach function
SHFt	Shift the Zero Reference Location after a TEACH
SLVE	Slave

Abbreviation	Description
SPd	Response speed
Std	Standard excess gain mode
Strt	Start
StoP	Stop
tch1, tch2	TEACH process selection (Channel 1, Channel 2)
totL	Totalizer
tot1, tot2	Total counts
uLoc	Unlock/unlocked
uuuu	Saturated signal (too much light)
wnd1, wnd2	Window size (Channel 1, Channel 2)
YES	Yes
ZEro	Zero—select the zero reference location

7 Troubleshooting

Use the following table to correct any error codes that appear in the Q4X.

Table 23: Error Codes

Error Code	Description	Resolution
----	No valid signal in range	Reposition the sensor or the target
UUUU	The signal is saturated (too much light)	Reposition the sensor or the target to increase the detection distance, or increase the angle of incidence between the sensor and the target
ErrE	EEPROM fault	Contact Banner Engineering to resolve
ErrL	Laser fault	Contact Banner Engineering to resolve
ErrC	Output short-circuited	Check the wiring for an electrical short circuit and to ensure that the wiring is correct
ErrS	System fault	Contact Banner Engineering to resolve

8 Accessories

8.1 Cordsets

4-Pin Threaded M12 Cordsets—Single Ended				
Model	Length	Style	Dimensions	Pinout (Female)
MQDC-406	2 m (6.56 ft)	Straight		
MQDC-415	5 m (16.4 ft)			
MQDC-430	9 m (29.5 ft)			
MQDC-450	15 m (49.2 ft)			
MQDC-406RA	2 m (6.56 ft)	Right-Angle		
MQDC-415RA	5 m (16.4 ft)			
MQDC-430RA	9 m (29.5 ft)			
MQDC-450RA	15 m (49.2 ft)			

4-Pin Threaded M12 Cordsets—Washdown, Stainless Steel, Single Ended				
Model	Length	Style	Dimensions	Pinout (Female)
MQDC-WDSS-0406	2 m (6.56 ft)	Straight		
MQDC-WDSS-0415	5 m (16.4 ft)			
MQDC-WDSS-0430	9 m (29.5 ft)			

4-Pin Threaded M12 Cordsets—Double Ended				
Model	Length	Style	Dimensions	Pinout
MQDEC-401SS	0.31 m (1 ft)	Male Straight/ Female Straight		Female
MQDEC-403SS	0.91 m (2.99 ft)			
MQDEC-406SS	1.83 m (6 ft)			Male
MQDEC-412SS	3.66 m (12 ft)			
MQDEC-420SS	6.10 m (20 ft)			
MQDEC-430SS	9.14 m (30.2 ft)			
MQDEC-450SS	15.2 m (49.9 ft)			

4-Pin Threaded M12 Cordsets—Double Ended, Oil Resistant				
Model	Length	Style	Dimensions	Pinout
MQDEC-401SS-PUR	0.3 m (0.98 ft)	Male Straight/ Female Straight		Female
MQDEC-403SS-PUR	1 m (3.28 ft)			
MQDEC-406SS-PUR	2 m (6.56 ft)			Male
MQDEC-415SS-PUR	5 m (16.4 ft)			
MQDEC-430SS-PUR	10 m (32.8 ft)			<p>1 = Brown 2 = White 3 = Blue 4 = Black</p>

4-Pin Threaded M12 Cordsets—Double Ended, Washdown, Stainless Steel				
Model	Length	Style	Dimensions	Pinout
MQDEC-WDSS-401SS	0.31 m (1 ft)	Male Straight/ Female Straight		Female
MQDEC-WDSS-403SS	0.91 m (2.99 ft)			
MQDEC-WDSS-406SS	1.83 m (6 ft)			Male
MQDEC-WDSS-412SS	3.66 m (12 ft)			
				<p>1 = Brown 2 = White 3 = Blue 4 = Black</p>

The following cordsets can be used to connect the Q4XTKLA600 or the Q4XTKLA610 the RSD1 Remote Display. Note that when this cordset is used IO-Link communications will not be enabled.

4-Pin Female and 5-Pin Male Threaded M12 Cordset—Double Ended				
Model	Length "L1"	Style	Pinout	
MQDC-4B5G01SS	0.30 m (0.98 ft)	Female Straight/ Male Straight	Male	
MQDC-4B5G06SS	1.83 m (6.00 ft)			
			<p>1 = Brown 2 = White 3 = Blue 4 = Not used 5 = Black</p>	

4-Pin Female and 5-Pin Male Threaded M12 Cordset—Double Ended			
Model	Length "L1"	Style	Pinout
			<p>Female</p> <p>1 = Brown 2 = White 3 = Blue 4 = Black</p>

When using the MQDC-5401SS/MQDC-5406SS cordsets to connect to the RSD1, the following cordsets can be used to connect to the RSD1 to a control system using the white wire (pin 2) as remote input for Remote TEACH, Laser Off, Laser On.

4-Pin Male and 5-Pin Female Threaded M12 Cordsets—Double Ended			
Model	Length "L1"	Style	Pinout
MQDC-5401SS	0.30 m (0.98 ft)	Female Straight/ Male Straight	<p>Male</p> <p>1 = Brown 2 = White 3 = Blue 4 = Black</p>
MQDC-5406SS	1.83 m (6.00 ft)		<p>Female</p> <p>1 = Brown 2 = Not Used 3 = Blue 4 = Black 5 = White</p>

8.2 Sensor Status Indicators

S15L Series In-Line Sensor Status Indicator						
Model	Input Type	LED Color	Dimensions	Female	Male	Wiring
S15LGYDQ	PNP	Power ON = Green Input Active = Yellow				<p>1 = Brown, 10 to 30 V DC 2 = White 3 = Blue, DC common 4 = Black, Sensor Input</p>
S15LGYNQ	NPN					

8.3 Brackets

All measurements are listed in millimeters, unless noted otherwise.

SMBQ4X..

- Swivel bracket with tilt and pan movement for precision adjustment
- Easy sensor mounting to extruded rail T-slots
- Metric and inch size bolts available
- Side mounting of some sensors with the 3 mm screws included with the sensor

A (Bolt Thread)

SMBQ4XFPA = 3/8 - 16 × 2¼ inches

SMBQ4XFAM10 = M10 - 1.5 × 50

SMBQ4XFAM12 = n/a; no bolt included. Mounts directly to 12 mm (½ inch) rods

B = 7 × M3 × 0.5

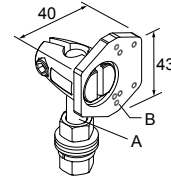

SMB18A

- Right-angle mounting bracket with a curved slot for versatile orientation
- 12-ga. stainless steel
- 18 mm sensor mounting hole
- Clearance for M4 (#8) hardware

Hole center spacing: A to B = 24.2

Hole size: A = \varnothing 4.6, B = 17.0 × 4.6, C = \varnothing 18.5

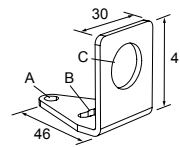

SMB18FA..

- Swivel bracket with tilt and pan movement for precision adjustment
- Easy sensor mounting to extruded rail T-slots
- Metric and inch size bolts available
- 18 mm sensor mounting hole

Hole size: B = \varnothing 18.1

Bolt Thread (A):

SMB18FA = 3/8 - 16 × 2 in

SMB18FAM10 = M10 - 1.5 × 50

SMB18FAM12 = n/a; no bolt included. Mounts directly to 12 mm (½ in) rods

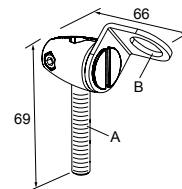

SMBAMS18P

- Flat SMBAMS series bracket with 18 mm hole
- Articulation slots for 90+° rotation
- 12-ga. (2.6 mm) cold-rolled steel

Hole center spacing: A = 26.0, A to B = 13.0

Hole size: A = 26.8 × 7.0, B = \varnothing 6.5, C = \varnothing 19.0

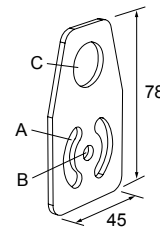

SMBAMS18RA

- Right-angle SMBAMS series bracket with 18 mm hole
- Articulation slots for 90+° rotation
- 12-ga. (2.6 mm) cold-rolled steel

Hole center spacing: A = 26.0, A to B = 13.0

Hole size: A = 26.8 × 7.0, B = \varnothing 6.5, C = \varnothing 19.0

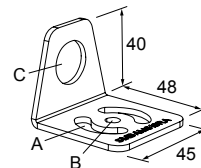

8.4 RSD1 Remote Display

Use the optional RSD1 for remote monitoring and configuration of a Q4XTKLAF600 or the Q4XTKLAF610.

See [Cordsets](#) on page 44 for the required cordsets.

RSD1 Remote Display					
Model	Output A and B	Dimensions		Male	Wiring
RSD1QP	Configurable				1 = Brown 2 = White 3 = Blue 4 = Black 5 = Gray

Corresponding Buttons

Sensor	Up	Down	Enter	Escape
RSD1 				
Q4X 				n/a

8.5 Aperture Kits—Threaded Barrel Models

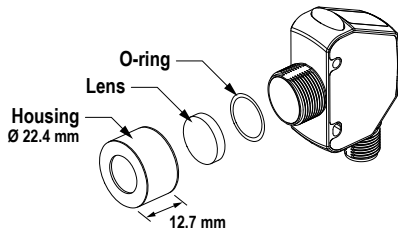

APG18S

Kit with glass lens to protect plastic sensor lens from chemical environments and weld splatter damage.
 Used with S18, M18, T18, TM18, and Q4X



Additional Information

- Borosilicate glass window protects the PMMA window from weld splatter and chemicals
- Adds 4.8 mm to the length of the threaded barrel
- Reduces excess gain by 30%; increase the response time to restore excess gain

8.6 Reference Targets

All measurements are listed in millimeters, unless noted otherwise.

BRT-Q4X-60X18

- Reference target for clear object detection or dual mode applications
- FDA grade acetal material

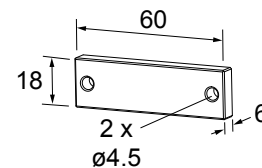

BRT-Q4X-60X50

- Reference target for clear object detection or dual mode applications
- FDA grade acetal material

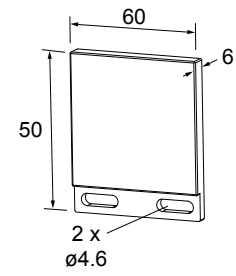

9 Product Support and Maintenance

9.1 Cleaning and Maintenance

Clean the sensor when soiled and use with care.

Handle the sensor with care during installation and operation. Sensor windows soiled by fingerprints, dust, water, oil, etc. may create stray light that may degrade the peak performance of the sensor. Blow the window clear using filtered, compressed air, then clean as necessary using only water and a lint-free cloth.

9.2 Contact Us

Banner Engineering Corp. headquarters is located at:

9714 Tenth Avenue North
Minneapolis, MN 55441, USA
Phone: + 1 888 373 6767

For worldwide locations and local representatives, visit www.bannerengineering.com.

9.3 Banner Engineering Corp. Limited Warranty

Banner Engineering Corp. warrants its products to be free from defects in material and workmanship for one year following the date of shipment. Banner Engineering Corp. will repair or replace, free of charge, any product of its manufacture which, at the time it is returned to the factory, is found to have been defective during the warranty period. This warranty does not cover damage or liability for misuse, abuse, or the improper application or installation of the Banner product.

THIS LIMITED WARRANTY IS EXCLUSIVE AND IN LIEU OF ALL OTHER WARRANTIES WHETHER EXPRESS OR IMPLIED (INCLUDING, WITHOUT LIMITATION, ANY WARRANTY OF MERCHANTABILITY OR FITNESS FOR A PARTICULAR PURPOSE), AND WHETHER ARISING UNDER COURSE OF PERFORMANCE, COURSE OF DEALING OR TRADE USAGE.

This Warranty is exclusive and limited to repair or, at the discretion of Banner Engineering Corp., replacement. **IN NO EVENT SHALL BANNER ENGINEERING CORP. BE LIABLE TO BUYER OR ANY OTHER PERSON OR ENTITY FOR ANY EXTRA COSTS, EXPENSES, LOSSES, LOSS OF PROFITS, OR ANY INCIDENTAL, CONSEQUENTIAL OR SPECIAL DAMAGES RESULTING FROM ANY PRODUCT DEFECT OR FROM THE USE OR INABILITY TO USE THE PRODUCT, WHETHER ARISING IN CONTRACT OR WARRANTY, STATUTE, TORT, STRICT LIABILITY, NEGLIGENCE, OR OTHERWISE.**

Banner Engineering Corp. reserves the right to change, modify or improve the design of the product without assuming any obligations or liabilities relating to any product previously manufactured by Banner Engineering Corp. Any misuse, abuse, or improper application or installation of this product or use of the product for personal protection applications when the product is identified as not intended for such purposes will void the product warranty. Any modifications to this product without prior express approval by Banner Engineering Corp will void the product warranties. All specifications published in this document are subject to change; Banner reserves the right to modify product specifications or update documentation at any time. Specifications and product information in English supersede that which is provided in any other language. For the most recent version of any documentation, refer to: www.bannerengineering.com.

For patent information, see www.bannerengineering.com/patents.

Index

A

adaptive tracking 12

B

buttons 19

C

channels 9
cleaning 50
complementary 11

D

dark operate 11
default settings 19
delay timer 14, 15
display 17
display view 17
dual (intensity + distance) 12
dual mode 12
dynamic background suppression
 12

E

end 17
error codes 43
exit setup mode 17

F

factory default 17, 19
far 15

H

high-speed 12

I

invert display 17
IO-Link 30

L

laser off 11
laser on 11
light operate 11
locking sensor buttons 19

M

maintenance 50
master 11, 29

N

near 15

O

one-point background suppression
 12
one-point window (foreground
 suppression) 12
one-shot 14, 15

P

PFM 29
programming the sensor 9, 11–20,
 22, 23, 26, 27, 29

pulse 11, 18, 19, 29

R

remote input 11, 18, 19
reset 17
rset 17
run mode 18

S

sensor programming 9, 11–20, 22,
 23, 26, 27, 29
slave 11, 29
switch point 18
switching thresholds 12
sync 11, 29

T

targets 15
TEACH mode 19, 20, 22, 23, 26, 27
totalizer 14, 15
troubleshooting 43
two-point static background
 suppression 12

U

unlock sensor buttons 19

Z

zero reference location 15