

ISL54216

USB 2.0 High-Speed/UART Dual SP3T (Dual 3 to 1 Multiplexer)

FN7701  
Rev.1.00  
Dec 5, 2018

The [ISL54216](#) is a single supply dual SP3T analog switch that operates from a single supply in the range of 2.7V to 4.6V. It was designed to multiplex between three different differential data sources, allowing the multiplexing of USB 2.0 high speed and/or UART data signals through a common headphone connector in Personal Media Players and other portable battery powered devices.

The switch channels have very low ON capacitance and high bandwidth to pass USB high speed signals (480Mbps) with minimal edge and phase distortion and can swing rail-to-rail to pass UART and full-speed USB signals.

The ISL54216 is available in a tiny 12 Ld 2.2mmx1.4mm ultra-thin QFN and 12 Ld 3mmx3mm TQFN packages. It operates over a temperature range of -40°C to +85°C.

**Related Literature**

- Technical Brief TB363 "Guidelines for Handling and Processing Moisture Sensitive Surface Mount Devices (SMDs)"

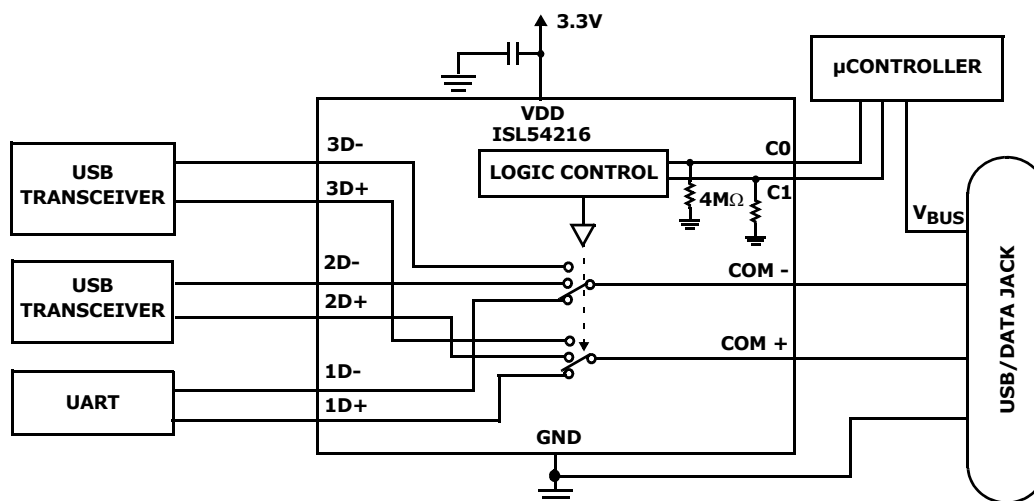
**Features**

- High Speed (480Mbps) and Full Speed (12Mbps) Signaling Capability per USB 2.0 on All Ports
- UART Capability on All Ports
- COM Pins Allow Negative Swings to -2V
- Compatible with Wired-OR Connected GND Referenced Audio Sources
- All Switches Open Mode
- Power OFF Protection
- COM Pins Overvoltage Tolerant to 5.5V
- Low ON Capacitance @ 240MHz 4pF
- -3dB Frequency 800MHz
- Single Supply Operation ( $V_{DD}$ )2.7V to 4.6V
- Available 12 Ld  $\mu$ TQFN and 12 Ld TQFN Packages
- Compliant with USB 2.0 Short Circuit Requirements Without Additional External Components
- Pb-Free (RoHS Compliant)

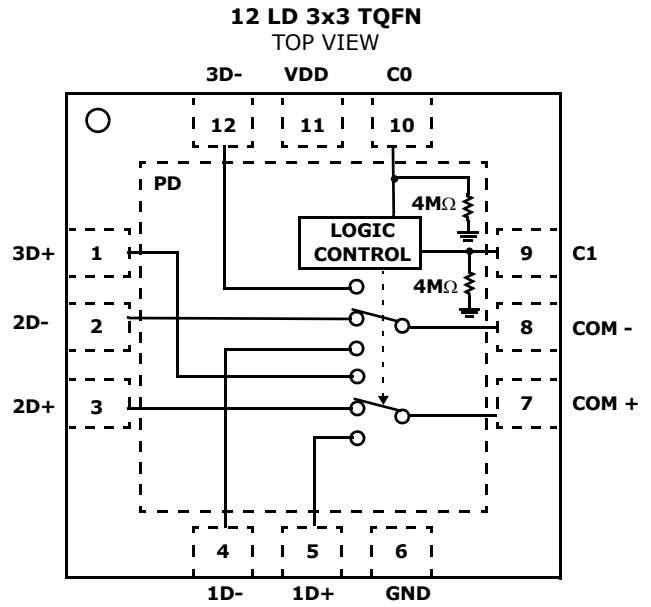
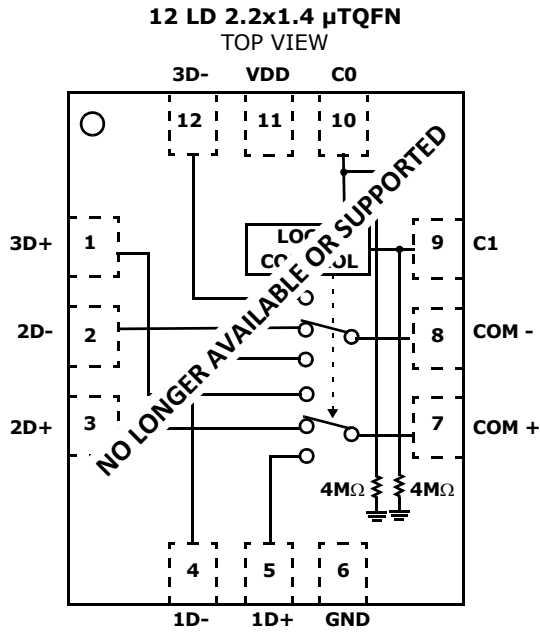
**Applications**

- MP3 and Other Personal Media Players
- Cellular/Mobile Phone
- Readers

**Application Block Diagram**



# Pin Configuration



NOTE:

1. ISL54216 Switches Shown for C1 = Logic "1" and C0 = Logic "0".

## Pin Descriptions

μTQFN	TQFN	NAME	FUNCTION
1	1	3D+	USB3 Differential Input
2	2	2D-	USB2 Differential Input
3	3	2D+	USB2 Differential Input
4	4	1D-	USB1 Differential Input
5	5	1D+	USB1 Differential Input
6	6	GND	Ground Connection
7	7	COM+	Data Common Pin
8	8	COM-	Data Common Pin
9	9	C1	Digital Control Input
10	10	C0	Digital Control Input
11	11	V <sub>DD</sub>	Power Supply
12	12	3D-	USB3 Differential Input
-	PD	PD	Thermal Pad. Tie to Ground or Float

## Truth Table

C1	C0	MODE	COMMENTS
0	0	Wired-OR Audio	All switches open
0	1	USB/UART #1	1D- and 1D+ ON
1	0	USB/UART #2	2D- and 2D+ ON
1	1	USB/UART #3	3D- and 3D+ ON

C0, C1: Logic "0" when  $\leq 0.5V$  or float, Logic "1" when  $\geq 1.4V$  with V<sub>DD</sub> in range of 2.7V to 3.6V.

## Ordering Information

PART NUMBER	PART MARKING	TEMP. RANGE (°C)	PACKAGE (Pb-Free)	PKG. DWG. #
ISL54216IRUZ-T (Notes 2, 3) <b>(No longer available or supported)</b>	GY	-40 to +85	12 Ld 2.2mmx1.4mm $\mu$ TQFN (Tape and Reel)	L12.2.2x1.4A
ISL54216IRTZ (Note 4)	4216	-40 to +85	12 Ld 3mmx3mm TQFN	L12.3x3A
ISL54216IRTZ-T (Note 2, 4)	4216	-40 to +85	12 Ld 3mmx3mm TQFN (Tape and Reel)	L12.3x3A
ISL54216EVAL1Z	Evaluation Board			

### NOTES:

- Please refer to [TB347](#) for details on reel specifications.
- These Pb-free plastic packaged products employ special Pb-free material sets; molding compounds/die attach materials and NiPdAu plate - e4 termination finish, which is RoHS compliant and compatible with both SnPb and Pb-free soldering operations. Pb-free products are MSL classified at Pb-free peak reflow temperatures that meet or exceed the Pb-free requirements of IPC/JEDEC J STD-020.
- These Pb-free plastic packaged products employ special Pb-free material sets, molding compounds/die attach materials, and 100% matte tin plate plus anneal (e3 termination finish, which is RoHS compliant and compatible with both SnPb and Pb-free soldering operations). Pb-free products are MSL classified at Pb-free peak reflow temperatures that meet or exceed the Pb-free requirements of IPC/JEDEC J STD-020.
- For Moisture Sensitivity Level (MSL), please see device information page for [ISL54216](#). For more information on MSL please see techbrief [TB363](#).

**Absolute Maximum Ratings**

$V_{DD}$ to GND	-0.3V to 5.5V
Input Voltages	
1D+, 1D-, 2D+, 2D-, 3D+, 3D-	-2V to 5.5V
C0, C1 (Note 6)	-0.3V to 5.5V
Output Voltages	
COM-, COM+	-2V to 5.5V
Continuous Current (1D-, 1D+, 2D-, 2D+, 3D-, 3D+)	$\pm 40$ mA
Peak Current (1D-, 1D+, 2D-, 2D+, 3D-, 3D+)	
(Pulsed 1ms, 10% Duty Cycle, Max)	$\pm 100$ mA
ESD Rating:	
Human Body Model (Tested per JESD22-A114F)	$> 5$ kV
Machine Model (Tested per JESD22-A115B)	$> 400$ V
Charged Device Model (Tested per JESD22-C110D)	$> 2$ kV
Latch-up (Tested per JESD-78B; Class 2, Level A)	... at $+85^{\circ}\text{C}$

**Thermal Information**

Thermal Resistance (Typical)	$\theta_{JA}$ ( $^{\circ}\text{C}/\text{W}$ )	$\theta_{JC}$ ( $^{\circ}\text{C}/\text{W}$ )
12 Ld $\mu\text{TQFN}$ Package (Notes 7, 10)	155	90
12 Ld TQFN Package (Notes 8, 9)	58	1.0
Maximum Junction Temperature (Plastic Package)	... $+150^{\circ}\text{C}$	
Maximum Storage Temperature Range	... $-65^{\circ}\text{C}$ to $+150^{\circ}\text{C}$	
Pb-Free Reflow Profile	... see <a href="#">TB493</a>	

**Operating Conditions**

Temperature Range	... $-40^{\circ}\text{C}$ to $+85^{\circ}\text{C}$
Supply Voltage Range	... 2.7V to 4.6V

**CAUTION:** Do not operate at or near the maximum ratings listed for extended periods of time. Exposure to such conditions may adversely impact product reliability and result in failures not covered by warranty.

**NOTES:**

- Signals on C1 and C0 exceeding GND by specified amount are clamped. Limit current to maximum current ratings.
- $\theta_{JA}$  is measured with the component mounted on a high effective thermal conductivity test board in free air. See Tech Brief TB379 for details.
- $\theta_{JA}$  is measured in free air with the component mounted on a high effective thermal conductivity test board with "direct attach" features. See Tech Brief TB379.
- For  $\theta_{JC}$ , the "case temp" location is the center of the exposed metal pad on the package underside.
- For  $\theta_{JC}$ , the "case temp" location is taken at the package top center.

**Electrical Specifications - 2.7V to 3.6V Supply** Test Conditions:  $V_{DD} = +3.0\text{V}$ ,  $\text{GND} = 0\text{V}$ ,  $V_{COH}$ ,  $V_{C1H} = 1.4\text{V}$ ,  $V_{COL}$ ,  $V_{C1L} = 0.5\text{V}$ , (Note 11), Unless Otherwise Specified. **Boldface limits apply over the operating temperature range,  $-40^{\circ}\text{C}$  to  $+85^{\circ}\text{C}$ .**

PARAMETER	TEST CONDITIONS	TEMP ( $^{\circ}\text{C}$ )	MIN (Notes 12, 13)	TYP	MAX (Notes 12, 13)	UNITS
<b>ANALOG SWITCH CHARACTERISTICS</b>						
Analog Signal Range, $V_{\text{ANALOG}}$	$V_{DD} = 2.7\text{V}$ to 4.6V	Full	<b>-1</b>	-	<b><math>V_{DD}</math></b>	V
ON-Resistance, $r_{\text{ON}}$	$V_{DD} = 2.7\text{V}$ , $I_{\text{COM}x} = 17\text{mA}$ , $V_{D+}$ or $V_{D-} = 0\text{V}$ to 400mV (see Figure 3, Note 15)	25	-	6	8	$\Omega$
		Full	-	-	<b>10</b>	$\Omega$
$r_{\text{ON}}$ Matching Between Channels, $\Delta r_{\text{ON}}$	$V_{DD} = 2.7\text{V}$ , $I_{\text{COM}x} = 17\text{mA}$ , $V_{D+}$ or $V_{D-} =$ Voltage at max $r_{\text{ON}}$ , (Notes 15, 16)	25	-	0.07	0.5	$\Omega$
		Full	-	-	<b>0.55</b>	$\Omega$
$r_{\text{ON}}$ Flatness, $R_{\text{FLAT(ON)}}$	$V_{DD} = 2.7\text{V}$ , $I_{\text{COM}x} = 17\text{mA}$ , $V_{D+}$ or $V_{D-} = 0\text{V}$ to 400mV, (Notes 14, 15)	25	-	0.32	0.8	$\Omega$
		Full	-	-	<b>1.2</b>	$\Omega$
ON-Resistance, $r_{\text{ON}}$	$V_{DD} = 3.3\text{V}$ , $I_{\text{COM}x} = 17\text{mA}$ , $V_{D+}$ or $V_{D-} = 3.3\text{V}$ (See Figure 3, Note 15)	+25	-	9.5	15	$\Omega$
		Full	-	-	<b>20</b>	$\Omega$
OFF Leakage Current, $I_{\text{XD+(OFF)}}$ or $I_{\text{XD-(OFF)}}$ , $I_{\text{COMX(OFF)}}$	$V_{DD} = 4.6\text{V}$ , All OFF Mode ( $C0 = 0.5\text{V}$ , $C1 = 0.5\text{V}$ ), $V_{\text{COM-}}$ or $V_{\text{COM+}} = 0.3\text{V}$ , 3.3V, $V_{\text{XD+}}$ or $V_{\text{XD-}} = 3.3\text{V}$ , 0.3V	25	-15	-	15	nA
		Full	<b>-20</b>	-	<b>20</b>	nA
ON Leakage Current, $I_{\text{XD+(ON)}}$ or $I_{\text{XD-(ON)}}$ , $I_{\text{COMX(ON)}}$	$V_{DD} = 4.6\text{V}$ , $V_{\text{XD+}}$ or $V_{\text{XD-}} = 0.3\text{V}$ , 3.3V, $V_{\text{COM-}}$ or $V_{\text{COM+}} = 0.3\text{V}$ , 3.3V	25	-20	-	20	nA
		Full	<b>-25</b>	-	<b>25</b>	nA
<b>DPDT DYNAMIC CHARACTERISTICS</b>						
All OFF to ON or ON to All OFF Address Transition Time, $t_{\text{TRANS}}$	$V_{DD} = 2.7\text{V}$ , $R_L = 50\Omega$ , $C_L = 10\text{pF}$ , (see Figure 1)	25	-	125	-	ns
Data Channel to Data Channel Address Transition Time, $t_{\text{TRANS}}$	$V_{DD} = 2.7\text{V}$ , $R_L = 50\Omega$ , $C_L = 10\text{pF}$ , (see Figure 1)	25	-	125	-	ns
Break-Before-Make Time Delay, $t_D$	$V_{DD} = 3.6\text{V}$ , $R_L = 50\Omega$ , $C_L = 10\text{pF}$ , (see Figure 2)	25	-	30	-	ns
Skew, ( $t_{\text{SKEWOUT}} - t_{\text{SKEWIN}}$ )	$V_{DD} = 3.0\text{V}$ , $R_L = 45\Omega$ , $C_L = 10\text{pF}$ , $t_R = t_F = 500\text{ps}$ at 480Mbps, (Duty Cycle = 50%) (see Figure 6)	25	-	75	-	ps

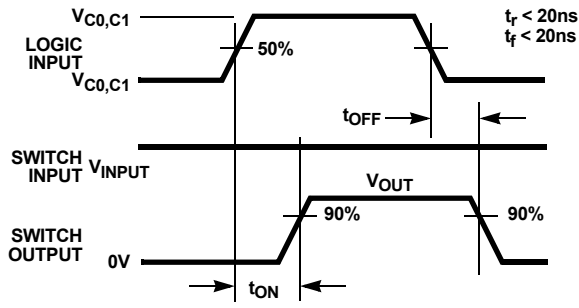
**Electrical Specifications - 2.7V to 3.6V Supply** Test Conditions:  $V_{DD} = +3.0V$ ,  $GND = 0V$ ,  $V_{C0H}$ ,  $V_{C1H} = 1.4V$ ,  $V_{C0L}$ ,  $V_{C1L} = 0.5V$ , (Note 11), Unless Otherwise Specified. **Boldface limits apply over the operating temperature range, -40°C to +85°C. (Continued)**

PARAMETER	TEST CONDITIONS	TEMP (°C)	MIN (Notes 12, 13)	TYP	MAX (Notes 12, 13)	UNITS
Total Jitter, $t_j$	$V_{DD} = 3.0V$ , $R_L = 50\Omega$ , $C_L = 10pF$ , $t_R = t_F = 500ps$ at 480Mbps	25	-	210	-	ps
Rise/Fall Degradation (Propagation Delay), $t_{pD}$	$V_{DD} = 3.0V$ , $R_L = 45\Omega$ , $C_L = 10pF$ , (see Figure 6)	25	-	250	-	ps
Crosstalk	$V_{DD} = 3.0V$ , $R_L = 50\Omega$ , $f = 240MHz$	25	-	-36	-	dB
OFF-Isolation	$V_{DD} = 3.0V$ , $R_L = 50\Omega$ , $f = 240MHz$	25	-	-32	-	dB
-3dB Bandwidth	Signal = 0dBm, 0.2VDC offset, $R_L = 50\Omega$ , $C_L = 5pF$	25	-	800	-	MHz
OFF Capacitance, $C_{XD+OFF}$ , $C_{XD-OFF}$	$f = 1MHz$ , $V_{DD} = 3.0V$ (see Figure 4)	25	-	3	-	pF
COM ON Capacitance, $C_{COM-(ON)}$ , $C_{COM+(ON)}$	$f = 1MHz$ , $V_{DD} = 3.0V$ (see Figure 4)	25	-	6	-	pF
COM ON Capacitance, $C_{COM-(ON)}$ , $C_{COM+(ON)}$	$f = 240MHz$ , $V_{DD} = 3.0V$	25	-	4	-	pF
<b>POWER SUPPLY CHARACTERISTICS</b>						
Power Supply Range, $V_{DD}$		Full	<b>2.7</b>		<b>4.6</b>	V
Positive Supply Current, $I_{DD}$ (ALL OFF Mode)	$V_{DD} = 3.6V$ , $C_1 = GND$ , $C_0 = GND$	25	-	6.5	8	$\mu A$
		Full	-	-	<b>15</b>	$\mu A$
Positive Supply Current, $I_{DD}$ (USB1 Mode)	$V_{DD} = 3.6V$ , $C_1 = GND$ , $C_0 = V_{DD}$	25	-	6.5	8	$\mu A$
		Full	-	-	<b>15</b>	$\mu A$
Positive Supply Current, $I_{DD}$ (USB2 Mode)	$V_{DD} = 3.6V$ , $C_1 = V_{DD}$ , $C_0 = GND$	25	-	6.5	8	$\mu A$
		Full	-	-	<b>15</b>	$\mu A$
Positive Supply Current, $I_{DD}$ (USB3 Mode)	$V_{DD} = 3.6V$ , $C_0 = C_1 = V_{DD}$	25	-	6.5	8	$\mu A$
		Full	-	-	<b>15</b>	$\mu A$
Power OFF COMx Current, $I_{COMx}$	$V_{DD} = 0V$ , $C_0 = C_1 = Float$ , $COMx = 5.25V$	25	-	-	1	$\mu A$
Power OFF Logic Current, $I_{C0}$ , $I_{C1}$	$V_{DD} = 0V$ , $C_0 = C_1 = 5.25V$	25	-	11	-	$\mu A$
Power OFF D+/D- Current, $I_{XD+}$ , $I_{XD-}$	$V_{DD} = 0V$ , $C_0 = C_1 = Float$ , $XD- = XD+ = 5.25V$	25	-	5	-	$\mu A$
<b>DIGITAL INPUT CHARACTERISTICS</b>						
$C_0$ , $C_1$ Voltage Low, $V_{C0L}$ , $V_{C1L}$	$V_{DD} = 2.7V$ to $3.6V$	Full	-	-	<b>0.5</b>	V
$C_0$ , $C_1$ Voltage High, $V_{C0H}$ , $V_{C1H}$	$V_{DD} = 2.7V$ to $3.6V$	Full	<b>1.4</b>	-	<b>5.25</b>	V
$C_0$ , $C_1$ Input Current, $I_{C0L}$ , $I_{C1L}$	$V_{DD} = 3.6V$ , $C_0 = C_1 = 0V$ or Float	Full	<b>-50</b>	6.2	<b>50</b>	nA
$C_0$ , $C_1$ Input Current, $I_{C0H}$ , $I_{C1H}$	$V_{DD} = 3.6V$ , $C_0 = C_1 = 3.6V$	Full	<b>-2</b>	1.6	<b>2</b>	$\mu A$
$C_0$ , $C_1$ Pull-Down Resistor, $R_{Cx}$	$V_{DD} = 3.6V$ , $C_0 = C_1 = 3.6V$ , Measure current into $C_0$ or $C_1$ pin and calculate resistance value.	Full	-	4	-	M $\Omega$

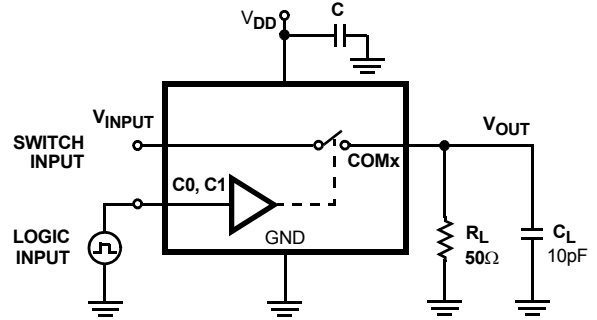
## NOTES:

- $V_{logic}$  = Input voltage to perform proper function.
- The algebraic convention, whereby the most negative value is a minimum and the most positive a maximum, is used in this data sheet.
- Parameters with MIN and/or MAX limits are 100% tested at +25°C, unless otherwise specified. Temperature limits established by characterization and are not production tested.
- Flatness is defined as the difference between maximum and minimum value of on-resistance over the specified analog signal range.
- Limits established by characterization and are not production tested.
- $r_{ON}$  matching between channels is calculated by subtracting the channel with the highest max  $r_{ON}$  value from the channel with lowest max  $r_{ON}$  value, between 1D+ and 1D- or between 2D+ and 2D- or between 3D+ and 3D-.

# Test Circuits and Waveforms



Logic input waveform is inverted for switches that have the opposite logic sense.



Repeat test for all switches.  $C_L$  includes fixture and stray capacitance.

$$V_{OUT} = V_{(INPUT)} \frac{R_L}{R_L + r_{ON}}$$

FIGURE 1A. ADDRESS  $t_{TRANS}$  MEASUREMENT POINTS

FIGURE 1B. ADDRESS  $t_{TRANS}$  TEST CIRCUIT

## FIGURE 1. SWITCHING TIMES

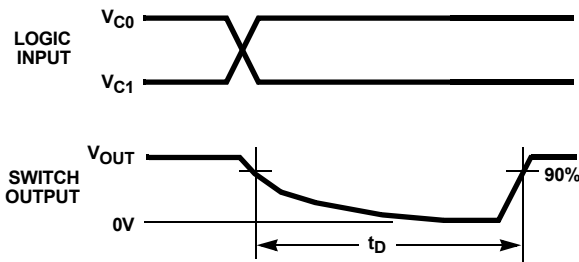
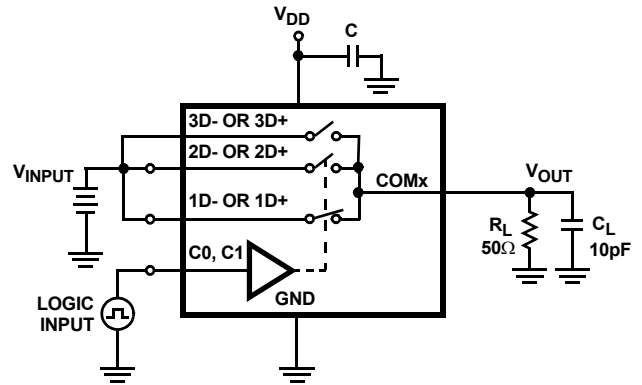


FIGURE 2A. MEASUREMENT POINTS



Repeat test for all switches.  $C_L$  includes fixture and stray capacitance.

FIGURE 2B. TEST CIRCUIT

## FIGURE 2. BREAK-BEFORE-MAKE TIME

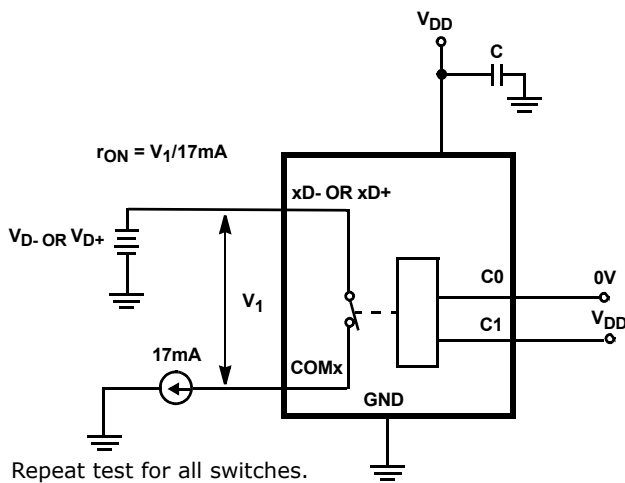


FIGURE 3.  $r_{ON}$  TEST CIRCUIT

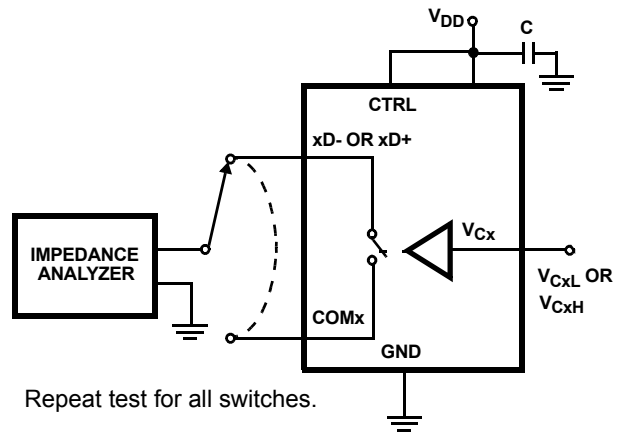


FIGURE 4. CAPACITANCE TEST CIRCUIT

## Test Circuits and Waveforms (Continued)

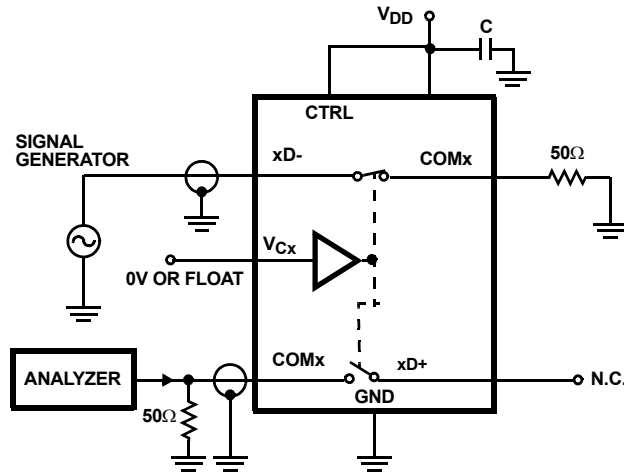


FIGURE 5. CROSTALK TEST CIRCUIT

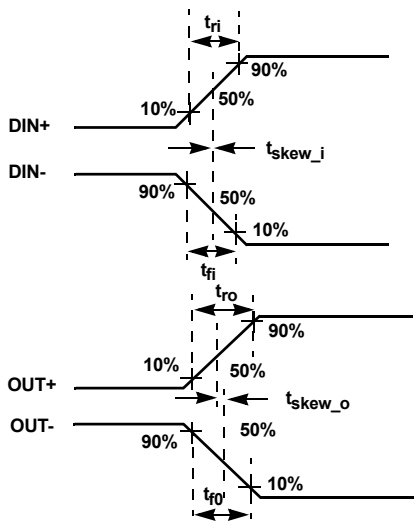
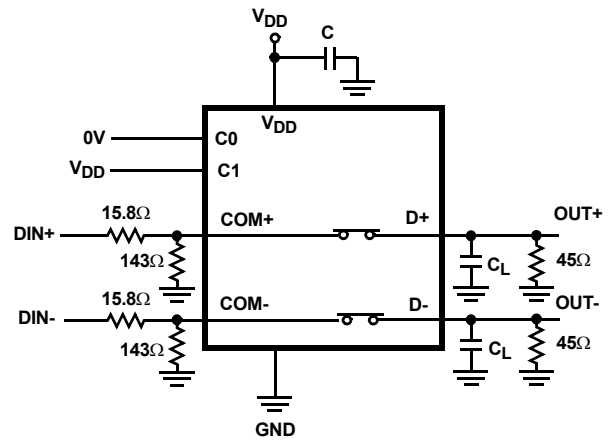


FIGURE 6A. MEASUREMENT POINTS

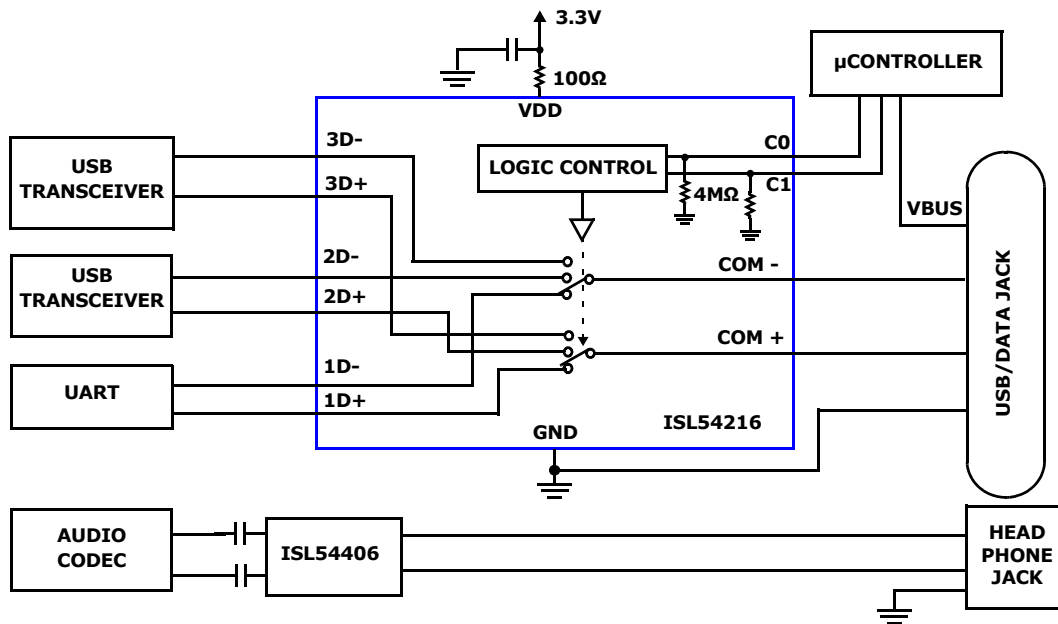


$|t_{ro} - t_{ri}|$  Delay Due to Switch for Rising Input and Rising Output Signals.  
 $|t_{fo} - t_{fi}|$  Delay Due to Switch for Falling Input and Falling Output Signals.  
 $|t_{skew_o}|$  Change in Skew through the Switch for Output Signals.  
 $|t_{skew_i}|$  Change in Skew through the Switch for Input Signals.

FIGURE 6B. TEST CIRCUIT

FIGURE 6. SKEW TEST

## Application Block Diagrams



### Detailed Description

The ISL54216 device consists of dual SP3T (single pole/triple throw) analog switches. It operates from a single DC power supply in the range of 2.7V to 4.6V. It was designed to function as differential 3 to 1 multiplexer to select between three different differential data signals. Its offered in tiny  $\mu$ TQFN and TQFN packages for use in MP3 players, PDAs, cellphones, and other personal media players.

A device consists of six  $6\Omega$  data switches. They were designed to pass high-speed USB differential data signals with minimal edge and phase distortion. They can swing rail-to-rail to pass UART and full-speed USB signals.

The COM pins can accept signals that swing below ground by as much as -2V. This allows an audio source to be wired-or connected at the COM pins.

The ISL54216 was specifically designed for MP3 players, personal media players and cellphone applications that need to combine three differential data channels into a single shared connector, thereby saving space and component cost. This functionality is shown in the Typical Application Block Diagram.

A detailed description of the switches is provided in the following sections.

#### Data Switches

The six data switches (1D+, 1D-, 2D+, 2D-, 3D+, 3D-) are  $6\Omega$  bidirectional switches that were specifically designed to pass high-speed USB differential data signals in the range of 0V to 400mV. The switches have low capacitance and high bandwidth to pass USB high-speed signals (480Mbps) with minimum edge and phase distortion to meet USB 2.0 signal quality specifications.

See Figures 11 and 12 for high-speed Eye Pattern taken with switch in the signal path.

These switches can also swing rail-to-rail and pass USB full-speed (12Mbps) and UART signals with minimal distortion. See Figure 13 for USB full-speed Eye Pattern taken with switch in the signal path.

The maximum normal operating signal range for the USB switches is from -1V to  $V_{DD}$ . The signal voltage at D- and D+ should not be allowed to exceed the  $V_{DD}$  voltage rail or go below ground by more than -1V for normal operation.

#### Fault Protection and Power-Off Protection

However, in the event that the USB 5.25V  $V_{BUS}$  voltage were shorted to one or both of the COM pins, the ISL54216 has fault protection circuitry to prevent damage to the ISL54216 part. The fault circuitry allows the signal pins (COM-, COM+, 1D-, 1D+, 2D-, 2D+, 3D-, 3D+) to be driven up to 5.25V while the  $V_{DD}$  supply voltage is in the range of 0V to 4.6V. This fault condition causes no stress to the IC.

In addition when  $V_{DD}$  is at 0V (ground) all switches are OFF and the fault voltage is isolated from the other side of the switch (Power-Off Protection).

When  $V_{DD}$  is in the range of 2.7V to 4.6V, the fault voltage will pass through to the output of an active switch channel. Note: During the fault condition normal operation is not guaranteed until the fault condition is removed.

#### ISL54216 Operation

The discussion that follows will discuss using the ISL54216 in the "Application Block Diagrams" on page 8.



**POWER**

The power supply connected at VDD (pin 11) provides power to the ISL54216 part. Its voltage should be kept in the range of 2.7V to 4.6V. In a typical application, V<sub>DD</sub> will be in the range of 2.7V to 4.3V and will be connected to the battery or LDO of the MP3 player or cellphone.

A 0.01μF or 0.1μF decoupling capacitor should be connected from the VDD pin to ground to filter out any power supply noise from entering the part. The capacitor should be located as close to the VDD pin as possible.

**LOGIC CONTROL**

The state of the ISL54216 device is determined by the voltage at the C1 pin (pin 9) and the C0 pin (pin 10). Refer to the "Truth Table" on page 2.

The C1 pin and C0 pin are internally pulled low through 4MΩ resistors to ground and can be tri-stated or left floating.

The C1 pin and C0 pin can be driven with a voltage that is higher than the V<sub>DD</sub> supply voltage. They can be driven up to 5.25V with the V<sub>DD</sub> supply in the range of 2.7V to 4.6V. Driving the logic higher than the supply rail will cause the logic current to increase. With V<sub>DD</sub> = 2.7V and V<sub>LOGIC</sub> = 5.25V, I<sub>LOGIC</sub> current is approximately 5.5μA.

**Logic Control Voltage Levels**

With V<sub>DD</sub> in the range of 2.7V to 3.6V the logic levels are: C1, C0 = Logic "0" (Low) when ≤ 0.5V or Floating. C1, C0 = Logic "1" (High) when ≥ 1.4V.

**ALL SWITCHES OFF Mode**

If the C1 pin = Logic "0" and C0 pin = Logic "0" the part will be in the ALL SWITCHES OFF mode. In this mode, the 3D- and 3D+ data switches, the 2D- and 2D+ data switches, and the 1D- and 1D+ data switches will be OFF (high impedance).

The COM pins can accommodate signals that swing below ground by as much as -2V. This allows an audio CODEC to be connected to the COM pins when the device is in the all off state.

**USB/UART1 Mode**

If the C1 pin = Logic "0" and C0 pin = Logic "1" the part will go into USB/UART1 mode. The 1D- and 1D+ switches are ON and the 2D- and 2D+ switches and 3D- and 3D+ will be OFF (high impedance).

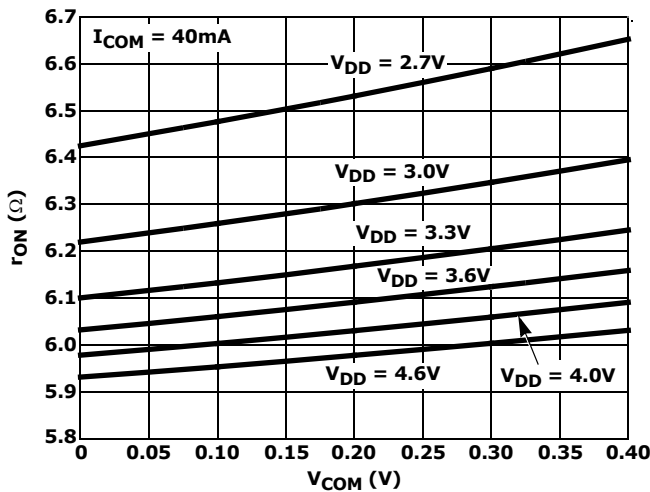
**USB2 Mode**

If the C1 = Logic "1" and C0 pin = Logic "0" the part will be in the USB/UART2 mode. The 2D- and 2D+ switches will be ON and the 1D- and 1D+ switches and the 3D- and 3D+ will be OFF (high impedance).

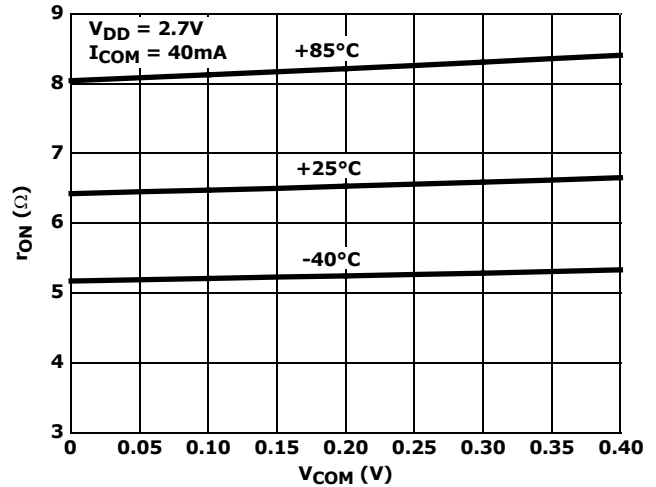
**USB3 Mode**

If the C1 pin = Logic "1" and C0 pin = Logic "1" the part will be in the USB/UART3 mode. The 3D- and 3D+ switches are ON, and the 1D- and 1D+ switches and 2D- and 2D+ switches will be OFF (high impedance).

**Typical Performance Curves** T<sub>A</sub> = +25°C, Unless Otherwise Specified.

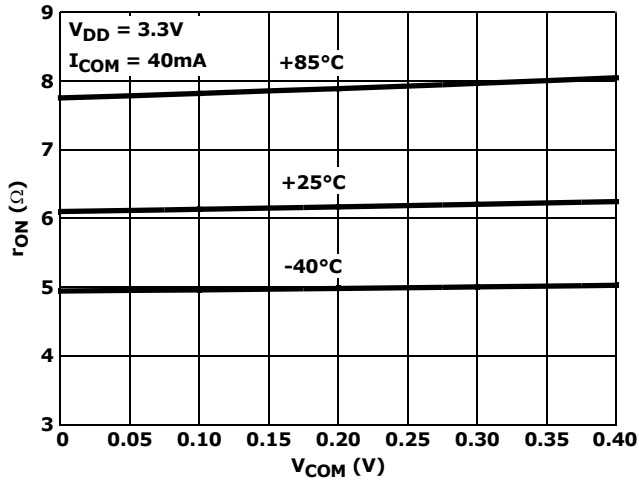


**FIGURE 7. ON-RESISTANCE vs SUPPLY VOLTAGE vs SWITCH VOLTAGE**

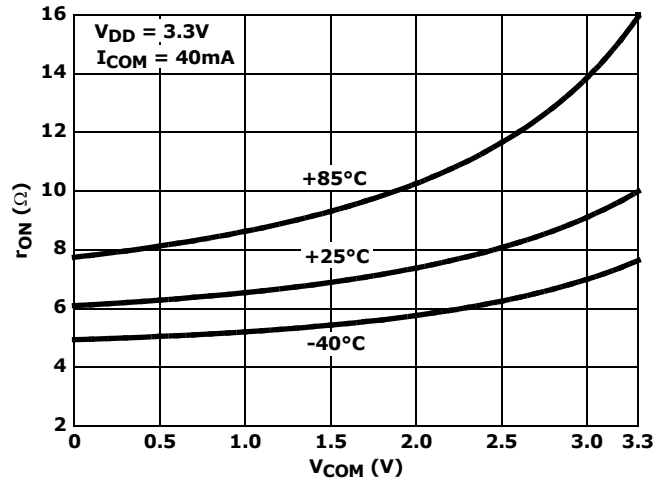


**FIGURE 8. ON-RESISTANCE vs SWITCH VOLTAGE vs TEMPERATURE**

**Typical Performance Curves**  $T_A = +25^\circ\text{C}$ , Unless Otherwise Specified. (Continued)

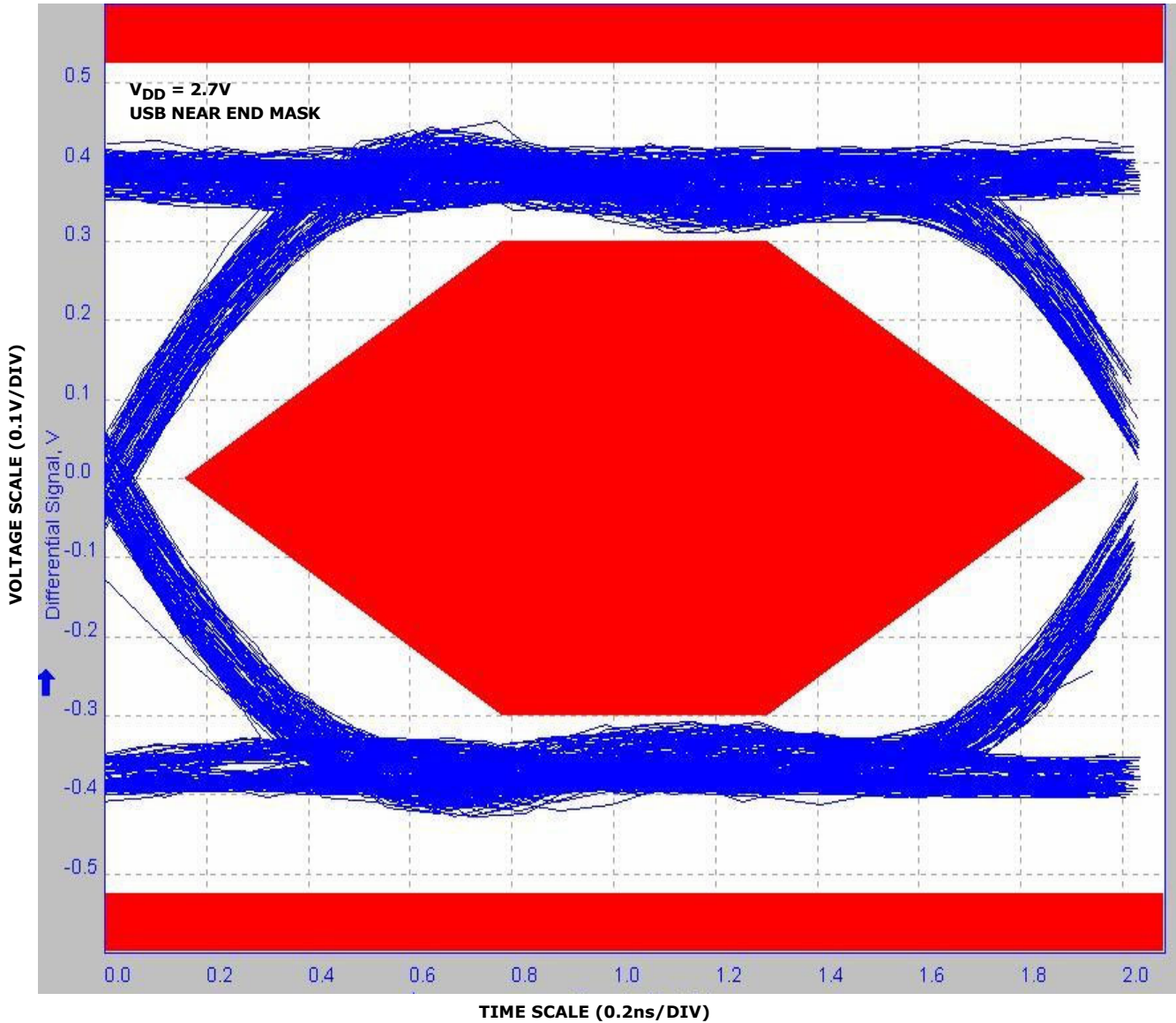


**FIGURE 9. ON-RESISTANCE vs SWITCH VOLTAGE vs TEMPERATURE**



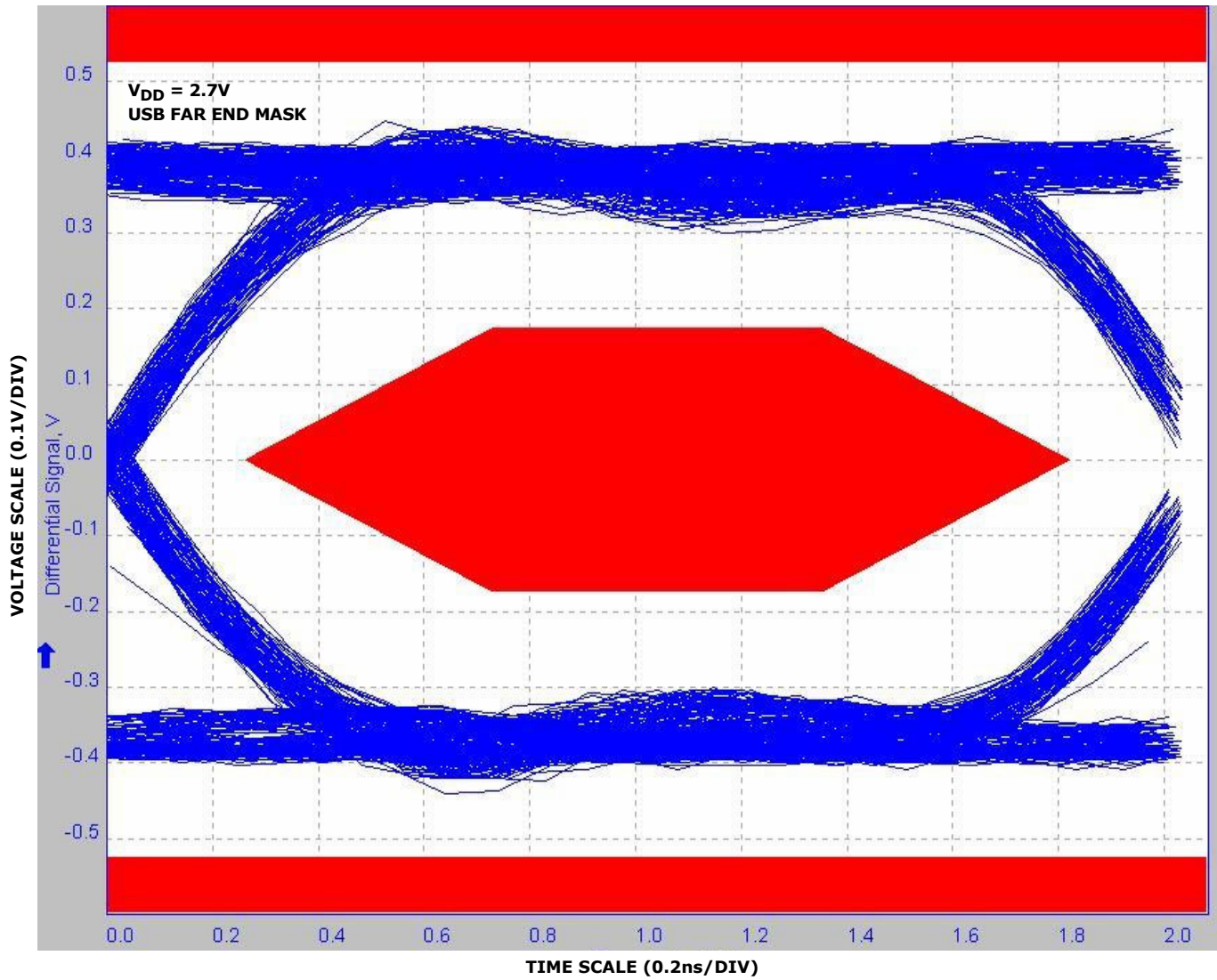
**FIGURE 10. ON-RESISTANCE vs SWITCH VOLTAGE vs TEMPERATURE**

**Typical Performance Curves**  $T_A = +25^\circ\text{C}$ , Unless Otherwise Specified. (Continued)



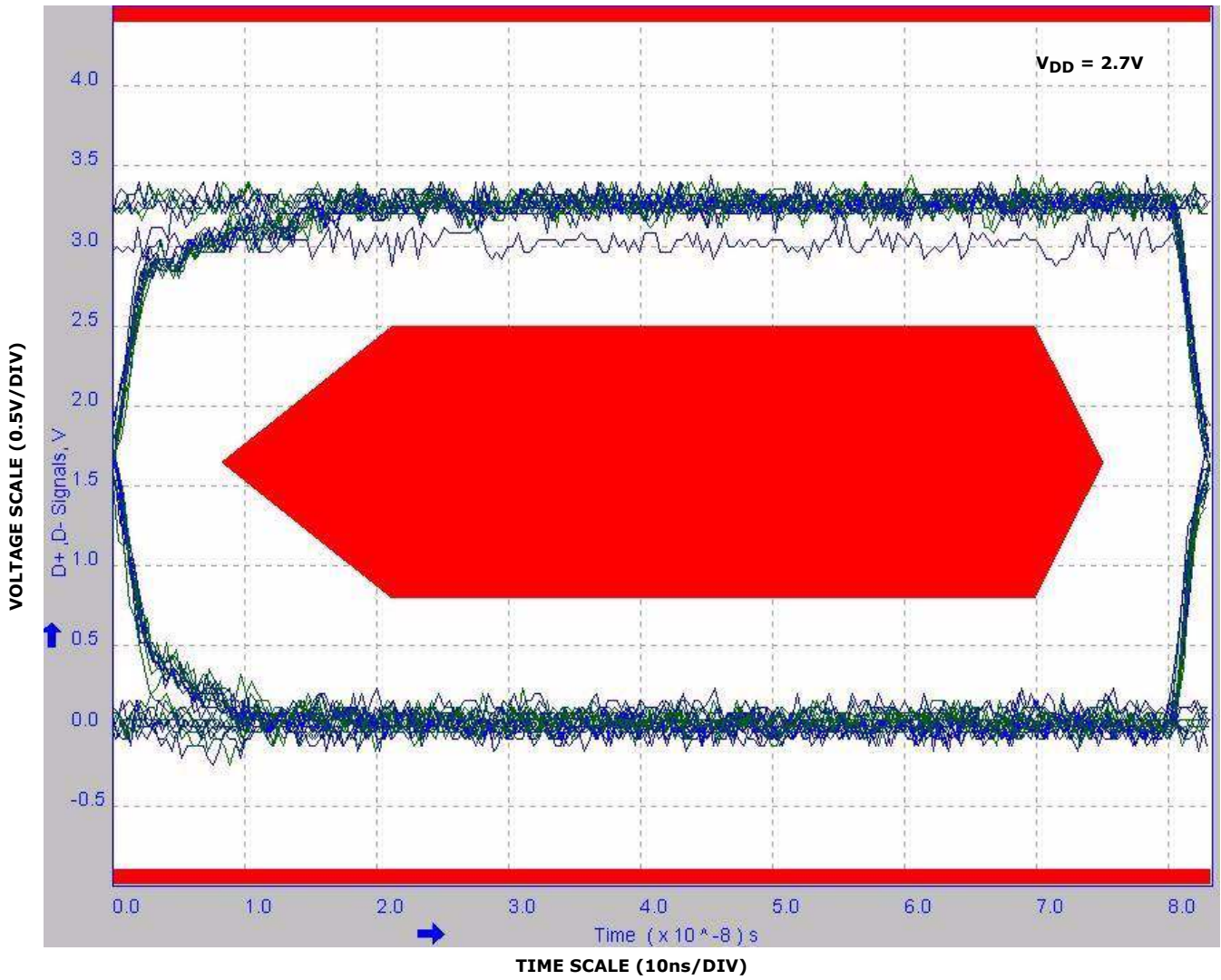
**FIGURE 11. EYE PATTERN: 480Mbps WITH USB SWITCHES IN THE SIGNAL PATH**

**Typical Performance Curves**  $T_A = +25^\circ\text{C}$ , Unless Otherwise Specified. (Continued)



**FIGURE 12. EYE PATTERN: 480Mbps WITH USB SWITCHES IN THE SIGNAL PATH**

**Typical Performance Curves**  $T_A = +25^\circ\text{C}$ , Unless Otherwise Specified. (Continued)



**FIGURE 13. EYE PATTERN: 12Mbps USB SIGNAL WITH USB SWITCHES IN THE SIGNAL PATH**

**Typical Performance Curves**  $T_A = +25^\circ\text{C}$ , Unless Otherwise Specified. **(Continued)**

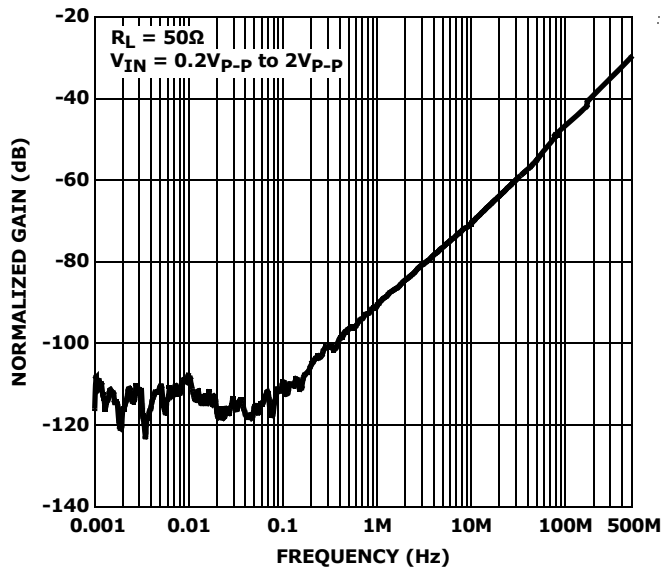


FIGURE 14. OFF-ISOLATION USB SWITCHES

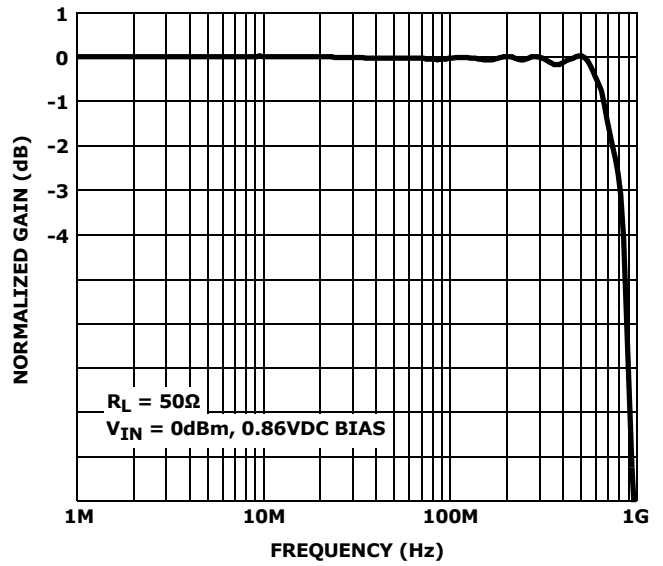


FIGURE 15. FREQUENCY RESPONSE

**Die Characteristics**

**SUBSTRATE AND TQFN THERMAL PAD  
POTENTIAL (POWERED UP):**

GND

**TRANSISTOR COUNT:**

837

**PROCESS:**

Submicron CMOS

---

## Revision History

DATE	REVISION	CHANGE
Dec 5, 2018	FN7701.1	Updated the Ordering Information on page 3. Removed Products section and updated the disclaimer.
Sep 27 2010	FN7701.0	Initial Release.

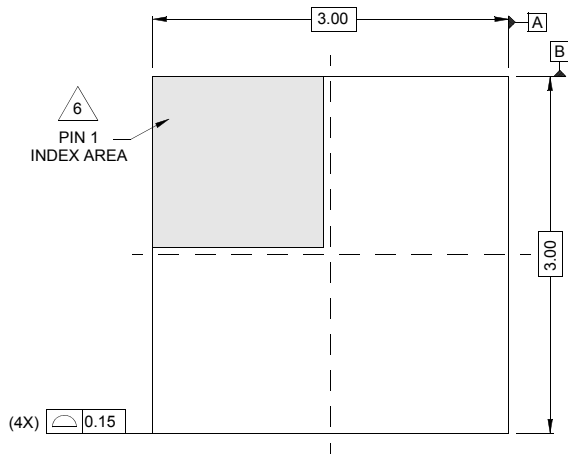
# Package Outline Drawings

For the most recent package outline drawing, see [L12.3x3A](#).

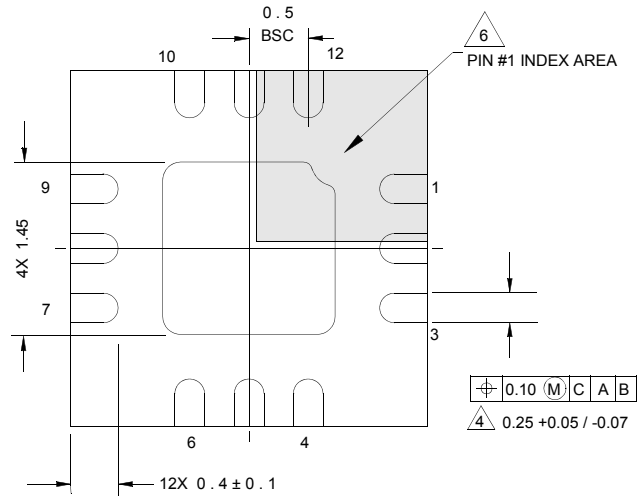
## L12.3x3A

12 LEAD THIN QUAD FLAT NO LEAD PLASTIC PACKAGE

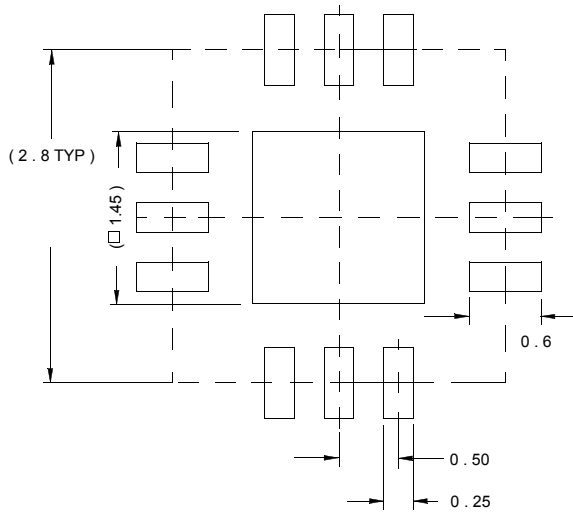
Rev 0, 09/07



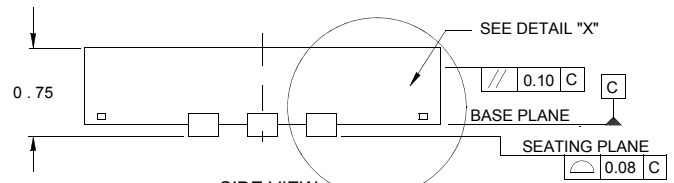
TOP VIEW



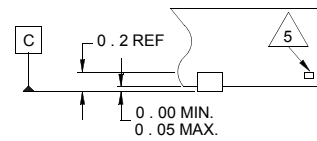
BOTTOM VIEW



TYPICAL RECOMMENDED LAND PATTERN



SIDE VIEW



DETAIL "X"

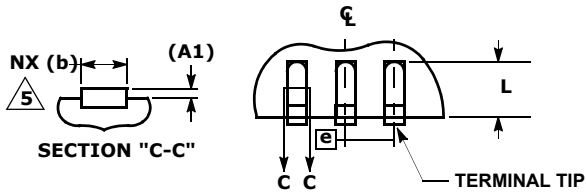
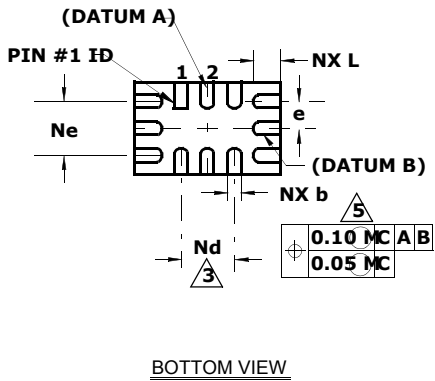
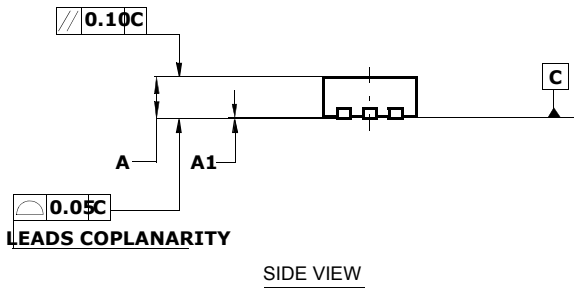
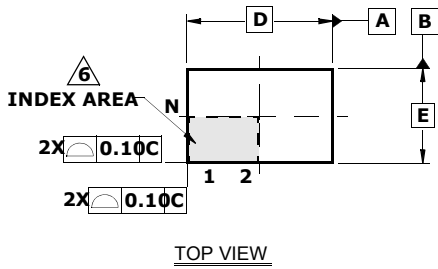
NOTES:

1. Dimensions are in millimeters.  
Dimensions in ( ) for Reference Only.
2. Dimensioning and tolerancing conform to AMSE Y14.5m-1994.
3. Unless otherwise specified, tolerance : Decimal  $\pm 0.05$
4. Dimension b applies to the metallized terminal and is measured between 0.18mm and 0.30mm from the terminal tip.
5. Tiebar shown (if present) is a non-functional feature.
6. The configuration of the pin #1 identifier is optional, but must be located within the zone indicated. The pin #1 identifier may be either a mold or mark feature.



### L12.2.2x1.4A

#### 12 LEAD ULTRA THIN QUAD FLAT NO-LEAD PLASTIC PACKAGE (UTQFN)

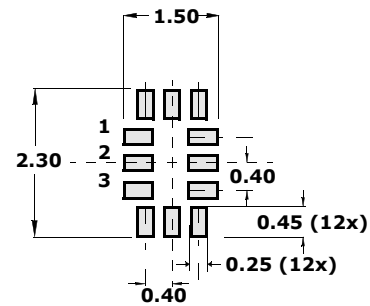


SYMBOL	MILLIMETERS			NOTES
	MIN	NOMINAL	MAX	
A	0.45	0.50	0.55	-
A1	-	-	0.05	-
A3	0.127 REF			-
b	0.15	0.20	0.25	5
D	2.15	2.20	2.25	-
E	1.35	1.40	1.45	-
e	0.40 BSC			-
k	0.20	-	-	-
L	0.35	0.40	0.45	-
N	12			2
Nd	3			3
Ne	3			3
θ	0	-	12	4

Rev. 0 12/06

NOTES:

1. Dimensioning and tolerancing conform to ASME Y14.5-1994.
2. N is the number of terminals.
3. Nd and Ne refer to the number of terminals on D and E side, respectively.
4. All dimensions are in millimeters. Angles are in degrees.
5. Dimension b applies to the metallized terminal and is measured between 0.15mm and 0.30mm from the terminal tip.
6. The configuration of the pin #1 identifier is optional, but must be located within the zone indicated. The pin #1 identifier may be either a mold or mark feature.
7. Maximum package warpage is 0.05mm.
8. Maximum allowable burrs is 0.076mm in all directions.
9. Same as JEDEC MO-255UABD except:  
No lead-pull-back, "A" MIN dimension = 0.45 not 0.50mm  
"L" MAX dimension = 0.45 not 0.42mm.
10. For additional information, to assist with the PCB Land Pattern Design effort, see TB389.



## Notice

1. Descriptions of circuits, software and other related information in this document are provided only to illustrate the operation of semiconductor products and application examples. You are fully responsible for the incorporation or any other use of the circuits, software, and information in the design of your product or system. Renesas Electronics disclaims any and all liability for any losses and damages incurred by you or third parties arising from the use of these circuits, software, or information.
  2. Renesas Electronics hereby expressly disclaims any warranties against and liability for infringement or any other claims involving patents, copyrights, or other intellectual property rights of third parties, by or arising from the use of Renesas Electronics products or technical information described in this document, including but not limited to, the product data, drawings, charts, programs, algorithms, and application examples.
  3. No license, express, implied or otherwise, is granted hereby under any patents, copyrights or other intellectual property rights of Renesas Electronics or others.
  4. You shall not alter, modify, copy, or reverse engineer any Renesas Electronics product, whether in whole or in part. Renesas Electronics disclaims any and all liability for any losses or damages incurred by you or third parties arising from such alteration, modification, copying or reverse engineering.
  5. Renesas Electronics products are classified according to the following two quality grades: "Standard" and "High Quality". The intended applications for each Renesas Electronics product depends on the product's quality grade, as indicated below.  
"Standard": Computers; office equipment; communications equipment; test and measurement equipment; audio and visual equipment; home electronic appliances; machine tools; personal electronic equipment; industrial robots; etc.  
"High Quality": Transportation equipment (automobiles, trains, ships, etc.); traffic control (traffic lights); large-scale communication equipment; key financial terminal systems; safety control equipment; etc.  
Unless expressly designated as a high reliability product or a product for harsh environments in a Renesas Electronics data sheet or other Renesas Electronics document, Renesas Electronics products are not intended or authorized for use in products or systems that may pose a direct threat to human life or bodily injury (artificial life support devices or systems; surgical implantations; etc.), or may cause serious property damage (space system; undersea repeaters; nuclear power control systems; aircraft control systems; key plant systems; military equipment; etc.). Renesas Electronics disclaims any and all liability for any damages or losses incurred by you or any third parties arising from the use of any Renesas Electronics product that is inconsistent with any Renesas Electronics data sheet, user's manual or other Renesas Electronics document.
  6. When using Renesas Electronics products, refer to the latest product information (data sheets, user's manuals, application notes, "General Notes for Handling and Using Semiconductor Devices" in the reliability handbook, etc.), and ensure that usage conditions are within the ranges specified by Renesas Electronics with respect to maximum ratings, operating power supply voltage range, heat dissipation characteristics, installation, etc. Renesas Electronics disclaims any and all liability for any malfunctions, failure or accident arising out of the use of Renesas Electronics products outside of such specified ranges.
  7. Although Renesas Electronics endeavors to improve the quality and reliability of Renesas Electronics products, semiconductor products have specific characteristics, such as the occurrence of failure at a certain rate and malfunctions under certain use conditions. Unless designated as a high reliability product or a product for harsh environments in a Renesas Electronics data sheet or other Renesas Electronics document, Renesas Electronics products are not subject to radiation resistance design. You are responsible for implementing safety measures to guard against the possibility of bodily injury, injury or damage caused by fire, and/or danger to the public in the event of a failure or malfunction of Renesas Electronics products, such as safety design for hardware and software, including but not limited to redundancy, fire control and malfunction prevention, appropriate treatment for aging degradation or any other appropriate measures. Because the evaluation of microcomputer software alone is very difficult and impractical, you are responsible for evaluating the safety of the final products or systems manufactured by you.
  8. Please contact a Renesas Electronics sales office for details as to environmental matters such as the environmental compatibility of each Renesas Electronics product. You are responsible for carefully and sufficiently investigating applicable laws and regulations that regulate the inclusion or use of controlled substances, including without limitation, the EU RoHS Directive, and using Renesas Electronics products in compliance with all these applicable laws and regulations. Renesas Electronics disclaims any and all liability for damages or losses occurring as a result of your noncompliance with applicable laws and regulations.
  9. Renesas Electronics products and technologies shall not be used for or incorporated into any products or systems whose manufacture, use, or sale is prohibited under any applicable domestic or foreign laws or regulations. You shall comply with any applicable export control laws and regulations promulgated and administered by the governments of any countries asserting jurisdiction over the parties or transactions.
  10. It is the responsibility of the buyer or distributor of Renesas Electronics products, or any other party who distributes, disposes of, or otherwise sells or transfers the product to a third party, to notify such third party in advance of the contents and conditions set forth in this document.
  11. This document shall not be reprinted, reproduced or duplicated in any form, in whole or in part, without prior written consent of Renesas Electronics.
  12. Please contact a Renesas Electronics sales office if you have any questions regarding the information contained in this document or Renesas Electronics products.
- (Note 1) "Renesas Electronics" as used in this document means Renesas Electronics Corporation and also includes its directly or indirectly controlled subsidiaries.  
(Note 2) "Renesas Electronics product(s)" means any product developed or manufactured by or for Renesas Electronics.

(Rev.4.0-1 November 2017)



### SALES OFFICES

Renesas Electronics Corporation

<http://www.renesas.com>

Refer to "<http://www.renesas.com/>" for the latest and detailed information.

#### Renesas Electronics Corporation

TOYOSU FORESIA, 3-2-24 Toyosu, Koto-ku, Tokyo 135-0061, Japan

#### Renesas Electronics America Inc.

1001 Murphy Ranch Road, Milpitas, CA 95035, U.S.A.  
Tel: +1-408-432-8888, Fax: +1-408-434-5351

#### Renesas Electronics Canada Limited

9251 Yonge Street, Suite 8309 Richmond Hill, Ontario Canada L4C 9T3  
Tel: +1-905-237-2004

#### Renesas Electronics Europe Limited

Dukes Meadow, Millboard Road, Bourne End, Buckinghamshire, SL8 5FH, U.K  
Tel: +44-1628-651-700

#### Renesas Electronics Europe GmbH

Arcadiastrasse 10, 40472 Düsseldorf, Germany  
Tel: +49-211-6503-0, Fax: +49-211-6503-1327

#### Renesas Electronics (China) Co., Ltd.

Room 1709 Quantum Plaza, No.27 ZhichunLu, Haidian District, Beijing, 100191 P. R. China  
Tel: +86-10-8235-1155, Fax: +86-10-8235-7679

#### Renesas Electronics (Shanghai) Co., Ltd.

Unit 301, Tower A, Central Towers, 555 Langao Road, Putuo District, Shanghai, 200333 P. R. China  
Tel: +86-21-2226-0888, Fax: +86-21-2226-0999

#### Renesas Electronics Hong Kong Limited

Unit 1601-1611, 16/F., Tower 2, Grand Century Place, 193 Prince Edward Road West, Mongkok, Kowloon, Hong Kong  
Tel: +852-2265-6688, Fax: +852 2886-9022

#### Renesas Electronics Taiwan Co., Ltd.

13F, No. 363, Fu Shing North Road, Taipei 10543, Taiwan  
Tel: +886-2-8175-9600, Fax: +886 2-8175-9670

#### Renesas Electronics Singapore Pte. Ltd.

80 Bendemeer Road, Unit #06-02 Hyflux Innovation Centre, Singapore 339949  
Tel: +65-6213-0200, Fax: +65-6213-0300

#### Renesas Electronics Malaysia Sdn.Bhd.

Unit 1207, Block B, Menara Amcorp, Amcorp Trade Centre, No. 18, Jln Persiaran Barat, 46050 Petaling Jaya, Selangor Darul Ehsan, Malaysia  
Tel: +60-3-7955-9390, Fax: +60-3-7955-9510

#### Renesas Electronics India Pvt. Ltd.

No.777C, 100 Feet Road, HAL 2nd Stage, Indiranagar, Bangalore 560 038, India  
Tel: +91-80-67208700, Fax: +91-80-67208777

#### Renesas Electronics Korea Co., Ltd.

17F, KAMCO Yangjae Tower, 262, Gangnam-daero, Gangnam-gu, Seoul, 06265 Korea  
Tel: +82-2-558-3737, Fax: +82-2-558-5338