

6.0 mm×3.5 mm Square Thin type

Japan

Light Touch Switches
for Reflow Soldering

Type: **EVQPP**



■ Features

- 6.0 mm×3.5 mm square thin type: 2.5 mm in height
- Excellent clear click feeling
- Reflow soldering available
- Dustproof structure

■ Recommended Applications

- Operating signal input switches for portable CD players, MD players, and communications equipment

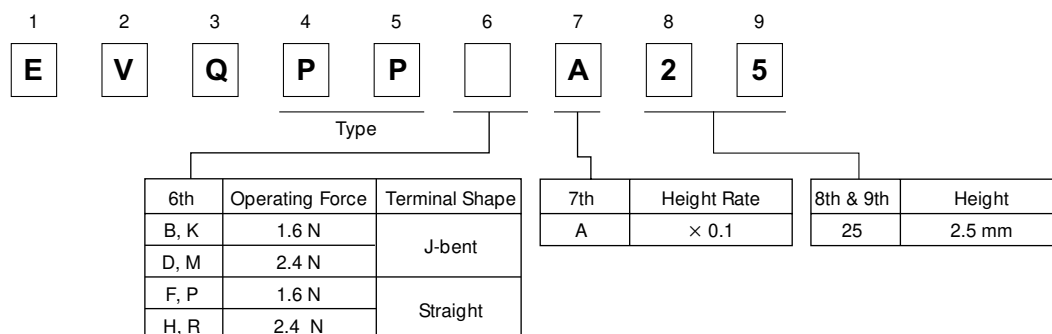

■ Explanation of Part Numbers



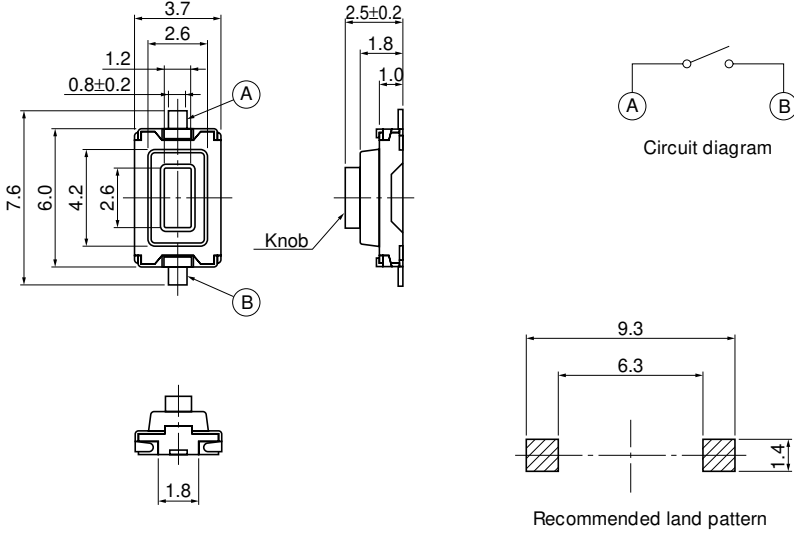

■ Specifications

Type		Snap action / Push-on type SPST	
Electrical	Rating	50 mA 12 Vdc max. (Resistive load)	
	Contact Resistance	100 mΩ max.	
	Insulation Resistance	100 MΩ min. (at 100 Vdc)	
	Dielectric Withstanding Voltage	250 Vac for 1 minute	
	Bouncing	10 ms max. (ON, OFF)	
Mechanical	Operating Force	1.6 N±0.5 N	2.4 N±0.6 N
	Travel	0.25 mm ^{+0.2} / _{-0.1} mm	
Endurance	Operating Life	50000 cycles min.	30000 cycles min.
	Operating Temperature	-40 °C to +85 °C (45 % to 85 % RH)	
	Storage Temperature	-40 °C to +85 °C (Bulk) -20 °C to +60 °C (Taping)	
Minimum Quantity/Packing Unit		4000 pcs. Embossed Taping (Reel Pack)	
Quantity/Carton		20000 pcs.	

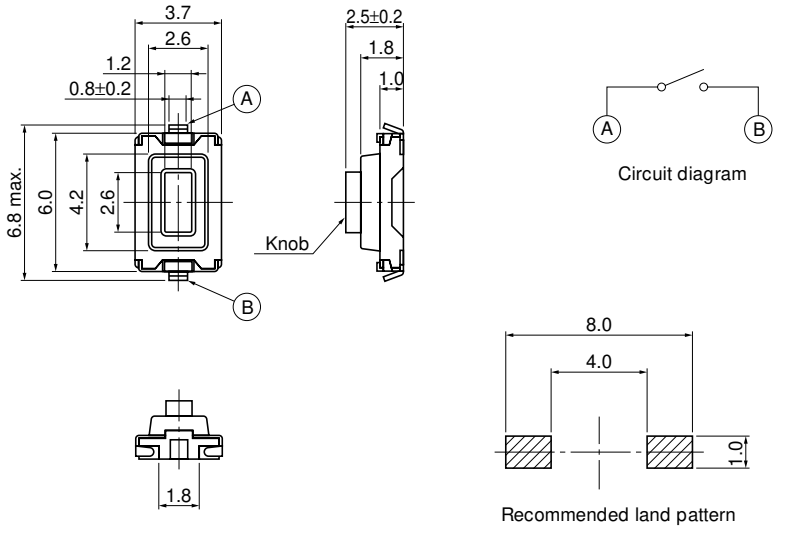
■ Dimensions in mm (not to scale)

<p>No. 1</p> <p>EVQPPF EVQPPH</p> <p>(Embossed Taping)</p> <p>With straight terminals Without ground terminal</p> 				
<p>Part Numbers</p>	<p>Operating Force</p>	<p>Height</p>	<p>Push Plate Color</p>	<p>Operating Life</p>
<p>EVQPPFA25</p>	<p>1.6 N</p>	<p>2.5 mm</p>	<p>Black</p>	<p>50000 cycles</p>
<p>EVQPPHA25</p>	<p>2.4 N</p>	<p>2.5 mm</p>	<p>White</p>	<p>30000 cycles</p>
<p>No. 2</p> <p>EVQPPB EVQPPD</p> <p>(Embossed Taping)</p> <p>With J-bent terminals Without ground terminal</p> 				
<p>Part Numbers</p>	<p>Operating Force</p>	<p>Height</p>	<p>Push Plate Color</p>	<p>Operating Life</p>
<p>EVQPPBA25</p>	<p>1.6 N</p>	<p>2.5 mm</p>	<p>Black</p>	<p>50000 cycles</p>
<p>EVQPPDA25</p>	<p>2.4 N</p>	<p>2.5 mm</p>	<p>White</p>	<p>30000 cycles</p>

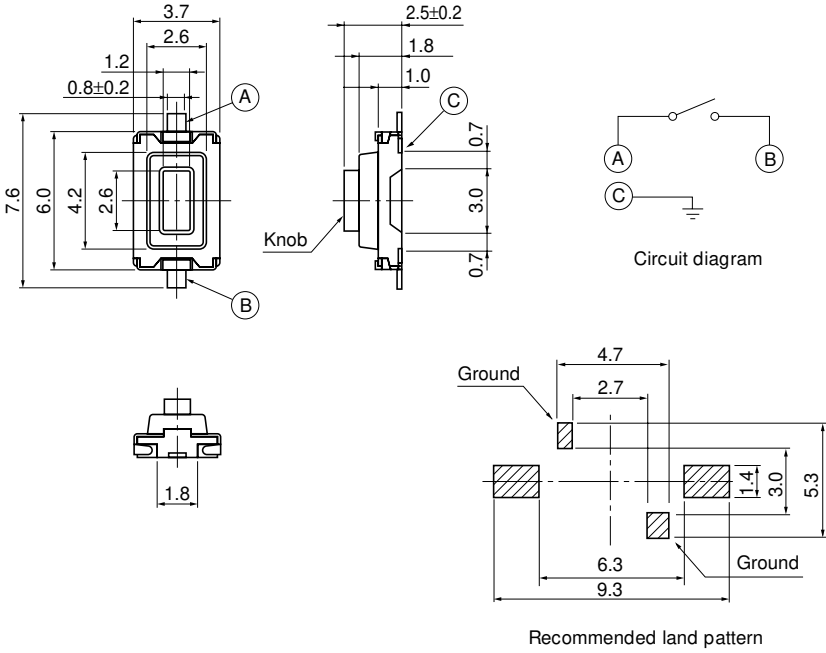
■ Dimensions in mm (not to scale)

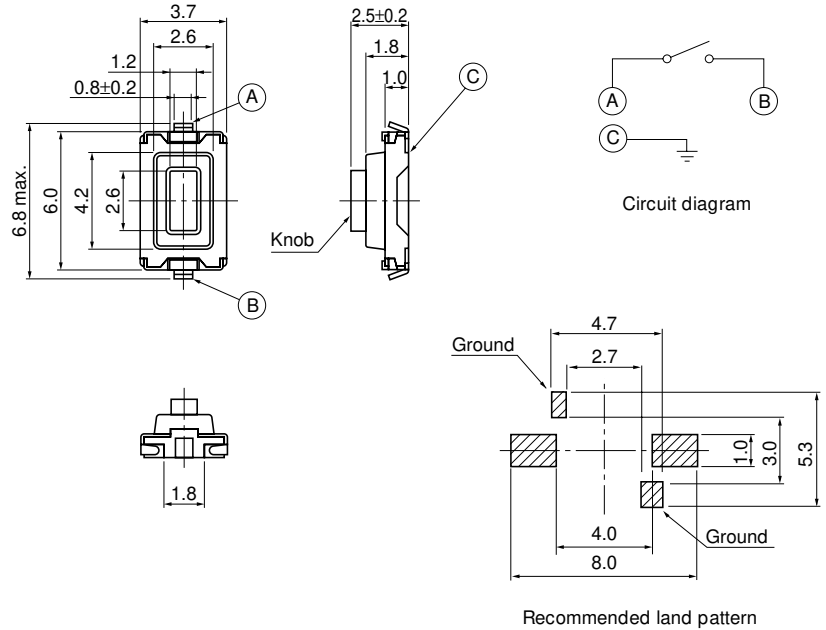
<p>No. 3</p> <p>EVQPPP EVQPPR</p> <p>(Embossed Taping)</p> <p>With straight terminals With ground terminal</p> 				
<p>Part Numbers</p>	<p>Operating Force</p>	<p>Height</p>	<p>Push Plate Color</p>	<p>Operating Life</p>
<p>EVQPPPA25</p>	<p>1.6 N</p>	<p>2.5 mm</p>	<p>Black</p>	<p>50000 cycles</p>
<p>EVQPPRA25</p>	<p>2.4 N</p>	<p>2.5 mm</p>	<p>White</p>	<p>30000 cycles</p>
<p>No. 4</p> <p>EVQPPK EVQPPM</p> <p>(Embossed Taping)</p> <p>With J-bent terminals With ground terminal</p> 				
<p>Part Numbers</p>	<p>Operating Force</p>	<p>Height</p>	<p>Push Plate Color</p>	<p>Operating Life</p>
<p>EVQPPKA25</p>	<p>1.6 N</p>	<p>2.5 mm</p>	<p>Black</p>	<p>50000 cycles</p>
<p>EVQPPMA25</p>	<p>2.4 N</p>	<p>2.5 mm</p>	<p>White</p>	<p>30000 cycles</p>

■ Recommended Reflow Soldering Conditions

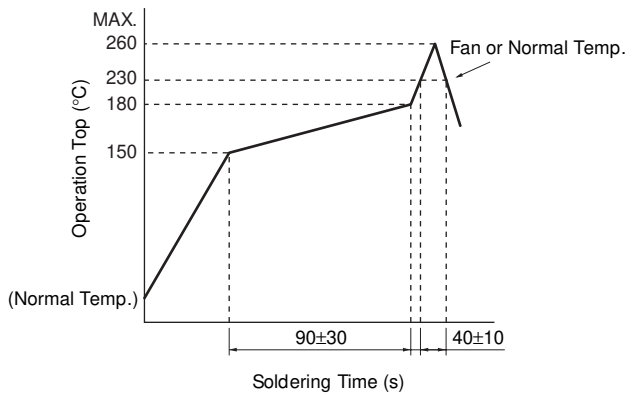

● Embossed Carrier Taping

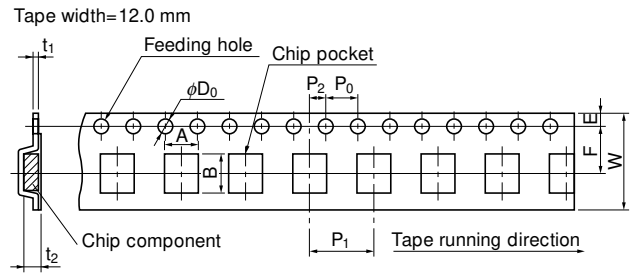

Unit: mm

Part No.	Height	A	B	W	F	E	P_1	P_2	P_0	D_0 Dia.	t_1	t_2
EVQPP	2.5	4.45 ± 0.20	8.3 max.	12.0 ± 0.3	5.5 ± 0.1	1.75 ± 0.10	8.0 ± 0.1	2.0 ± 0.1	4.0 ± 0.1	$1.5^{+0.1}_{-0}$	0.30 ± 0.05	2.55 ± 0.20

● Standard Reel Dimensions in mm (not to scale)

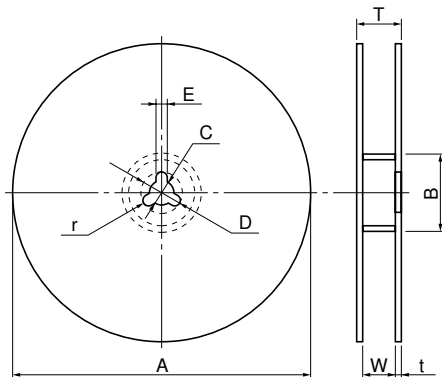

Item	A	B	C	D	E
Rate (mm)	$\phi 370.0 \pm 2.0$	$\phi 50.0$ min.	$\phi 13.0 \pm 0.5$	$\phi 21.0 \pm 1.0$	2.0 ± 0.5

Item	W	T	t	r
Rate (mm)	14.0 ± 1.5	—	1.0 to 3.0	1.0 ± 0.5