

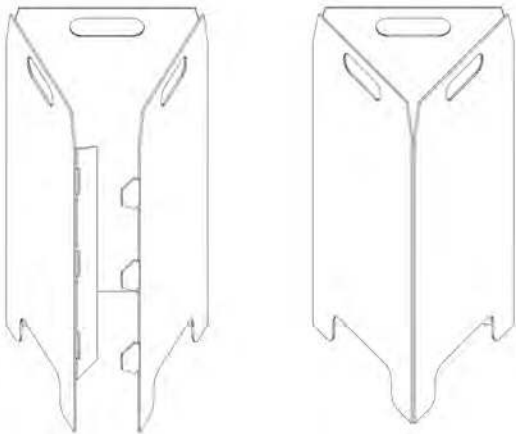

FEATURES

- Easy way to identify an ESD Protected Area (EPA)
- May be used to setup a temporary ESD work area
- Convenient - can be moved around where needed
- No holes or tape on the walls and doors to install
- Easy to read and see
- Hand hole along top of sign for ease of moving
- Made from resilient and durable Plastek™ material
- Conductive, Rtt 10E2 - 10E4 ohms
- Item ships flat, easy to assemble
- Size: 24" (H) x 12" (W)
- Made in America



Assembly Instructions:

1. Fold all panels along score lines
2. Align lock tabs with corresponding slots on opposite panel
3. Insert lock tabs to finish assembly.

Unless otherwise noted, tolerance $\pm 10\%$

Specifications and procedures subject to change without notice.



MADE IN AMERICA

ESD AREA SIGN

PROTEKTIVE PAK
13520 MONTE VISTA AVENUE, CHINO, CA 91710
PHONE (909) 627-2578, FAX (909) 363-7331
ProtektivePak.com

DRAWING NUMBER
39170

DATE
February
2011

PROTEKTIVE PAK