

参考図：ご確認。正式には別途納入仕様書をご請求願います。

TO
R

COUNT	DESCRIPTION OF REVISIONS	BY	CHKD	DATE	COUNT	DESCRIPTION OF REVISIONS	BY	CHKD	DATE
△					△				
△					△				
APPLICABLE STANDARD									
RATING	OPERATING TEMPERATURE RANGE	-25 °C TO +85 °C			STORAGE TEMPERATURE RANGE	-10 °C TO +60 °C			
	VOLTAGE	AC 100 V, DC 140 V							
	CURRENT	1 A			APPLICABLE CABLE				
SPECIFICATIONS									
ITEM		TEST METHOD			REQUIREMENTS			QT	AT
CONSTRUCTION									
GENERAL EXAMINATION		VISUALLY AND BY MEASURING INSTRUMENT.			ACCORDING TO DRAWING.			×	×
MARKING		CONFIRMED VISUALLY.						×	×
ELECTRIC CHARACTERISTICS									
CONTACT RESISTANCE	CONTACT SHALL BE MEASURED AT DC 1 A			10 mΩ MAX.			×	×	
	CONTACT SHALL BE MEASURED AT DC — A			— mΩ MAX.			—	—	
INSULATION RESISTANCE	100 V DC.			200 MΩ MIN.			×	×	
VOLTAGE PROOF	300 V AC FOR 1 min.			NO FLASHOVER OR BREAKDOWN.			×	×	
MECHANICAL CHARACTERISTICS									
CONTACT INSERTION AND WITHDRAWAL FORCES	φ0.610 ⁰ -0.003 BY STEEL GAUGE.			INSERTION AND WITHDRAWAL FORCES: 0.2 N MIN.			×	—	
CONNECTOR INSERTION AND WITHDRAWAL FORCES	MEASURED BY APPLICABLE CONNECTOR.			INSERTION AND WITHDRAWAL FORCES: 30 N MAX.			×	—	
MECHANICAL OPERATION	1000 TIMES INSERTIONS AND EXTRACTIONS.			CONTACT RESISTANCE: 15 mΩ MAX.			×	—	
				— RESISTANCE: — mΩ MAX.			—	—	
VIBRATION	FREQUENCY 10 TO 55 Hz, SINGLE AMPLITUDE 0.75 mm — m/s ² AT 2 h, FOR 3 DIRECTIONS.			① NO ELECTRICAL DISCONTINUITY OF 10 μs. ② NO DAMAGE, CRACK AND LOOSENESS, OF PARTS.			×	—	
SHOCK	490 m/s ² DIRECTIONS OF PULSE 11 ms AT 3 TIMES FOR 3 DIRECTIONS.			① NO ELECTRICAL DISCONTINUITY OF 10 μs. ② NO DAMAGE, CRACK AND LOOSENESS, OF PARTS.			×	—	
ENVIRONMENTAL CHARACTERISTICS									
DAMP HEAT (STEADY STATE)	EXPOSED AT 40 °C, 90 TO 95 %, 96 h.			① INSULATION RESISTANCE: 20 MΩ MIN. ② NO DAMAGE, CRACK AND LOOSENESS OF PARTS.			×	—	
RAPID CHANGE OF TEMPERATURE	TEMPERATURE -55 → R/T ⁰ → +85 → R/T °C TIME 30 → 10 TO 15 → 30 → 10 TO 15 min UNDER 5 CYCLES.			① INSULATION RESISTANCE: 1000 MΩ MAX. ② NO DAMAGE, CRACK AND LOOSENESS OF PARTS.			×	—	
CORROSION SALT MIST	EXPOSED IN 5 % SALT WATER SPRAY FOR 48 h.			NO HEAVY CORROSION.			×	—	
DRY HEAT	EXPOSED AT +85 °C, 96 h.			NO DAMAGE, CRACK AND LOOSENESS OF PARTS.			×	—	
COLD	EXPOSED AT -55 °C, 96 h.			NO DAMAGE, CRACK AND LOOSENESS OF PARTS.			×	—	
RESISTANCE TO SOLDERING HEAT	SOLDER TEMPERATURE, +350 °C, FOR SOLDERING DURATION, 3 ₀ ⁺¹ s.			NO DEFORMATION OF CASE OF EXCESSIVE LOOSENESS OF THE TERMINALS.			×	—	
SOLDERABILITY	SOLDERED AT SOLDER TEMPERATURE, +350 °C FOR SOLDERING DURATION, 2 TO 3 s.			WETTING ON SOLDER SURFACE. NO SOLDER CLUSTER.			×	—	
REMARKS				DRAWN	DESIGNED	CHECKED	APPROVED	RELEASED	
NOTE(1) R/T : ROOM TEMPERATURE				H.Kawashima	H.Kawashima	J. Akiyama	I. SaTo		
Unless otherwise specified, refer to JIS C 5402.				'05.11.29	'05.11.29	'05.11.30	05.11.30		
Note QT:Qualification Test AT:Assurance Test ×:Applicable Test									
HRS HIROSE ELECTRIC CO., LTD.				SPECIFICATION SHEET			PART NO. KMC9BRD-4S (71)		
CODE NO. (OLD)		DRAWING NO.		CODE NO.				1	
CL		ELC4-007490-71		CL110-0015-3-71				1	



2005/12/16 08:45:21 CAROL TRIBBLE

参考図：ご確認用。正式には別途納入仕様書をご請求願います。

1				2				3				4			
COUNT	DESCRIPTION OF REVISIONS	BY	CHKD	DATE	COUNT	DESCRIPTION OF REVISIONS	BY	CHKD	DATE	COUNT	DESCRIPTION OF REVISIONS	BY	CHKD	DATE	
△					△					△					
△					△					△					
△					△					△					

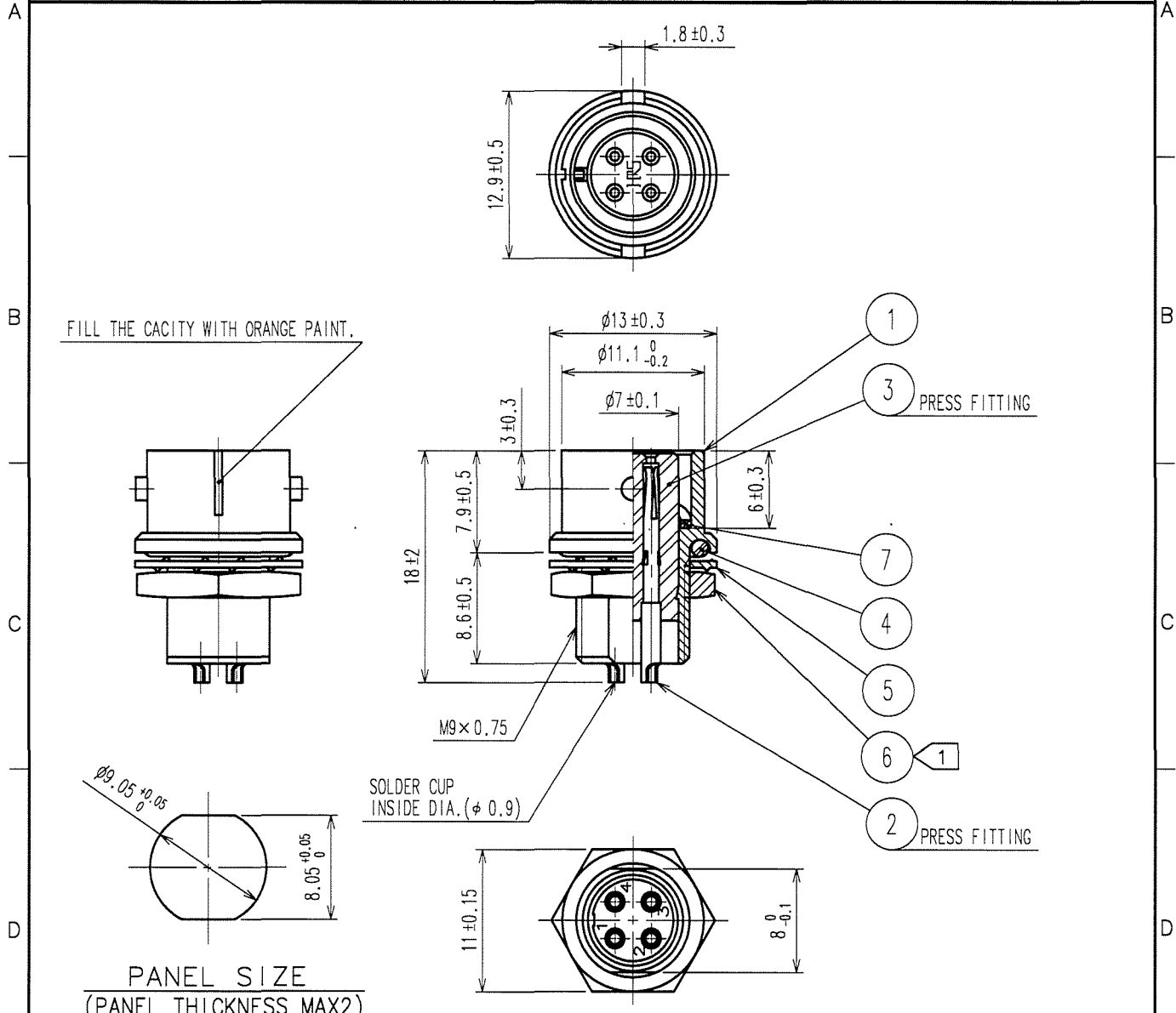

NOTES ① THE RECOMMENDED TIGHTENING TORQUE OF REF.NO.⑥: 1.5 TO 2N·m
 COATING WITH LOCTITE 242, HENKEL JAPAN OR EQUIVALENT IS RECOMMENDED TO PREVENT REF.NO.⑥ FROM LOOSENING.
 ② SURFACE PLATING: GOLD PLATING 2μm min.
 UNDER PLATING : NICKEL PLATING 3μm min.

4	CR	(BLACK)			
3	POLYACETAL	(WHITE)	7	BERYLLIUM COPPER	NICKEL PLATING
2	PHOSPOR BRONZE	②	6	STEEL	NICKEL PLATING
1	ZINC ALLOY	NICKEL PLATING	5	STEEL	NICKEL PLATING
NO.	MATERIAL	FINISH, REMARKS	NO.	MATERIAL	FINISH, REMARKS

CODE NO. (OLD)		DRAWN	DESIGNED	CHECKED	APPROVED	RELEASED
		H. Kawashima	H. Kawashima	T. Ohigama	M. Sato	
		05.11.18	05.11.18	05.11.25	05.11.30	
DRAWING NO. EDC4-007490-71			PART NO. KMC9BRD-4S(71)			
CODE NO. HRS HIROSE ELECTRIC CO., LTD.			CODE NO. CL110-0015-3-71			1/1

TO
R