

6

5

4

3

2

44610

D

D

C

C

B

B

A

A

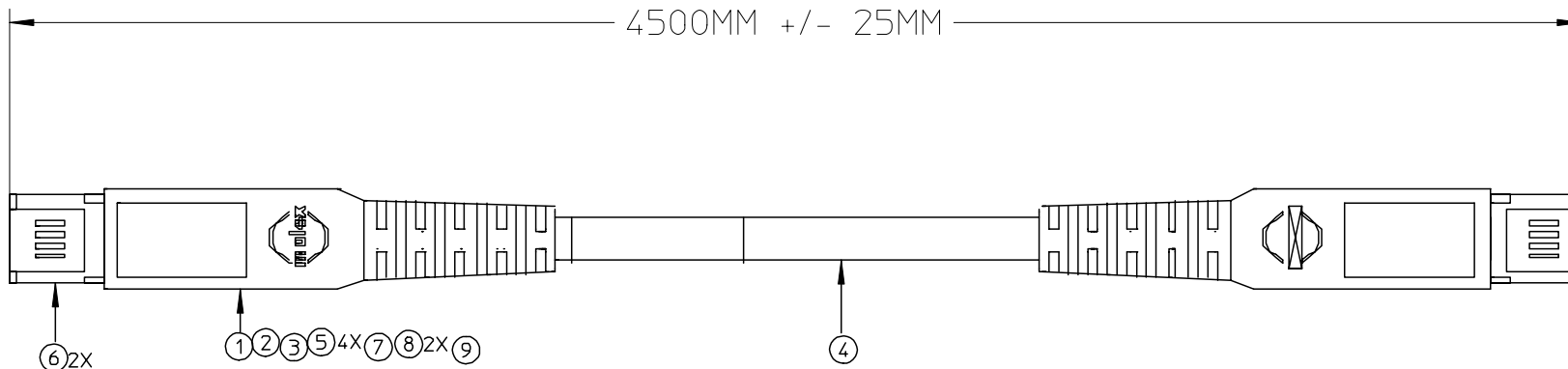

| ITEM | DESCRIPTION                           | PART NUMBER | QTY  |
|------|---------------------------------------|-------------|------|
| 9    | SHRINK TUB, 1/16" UL/VW-1/CSA MARKED  | 79941-1240  | A/R  |
| 8    | CRIMP FERRULE 5.30 MM NOMINAL         | 452470001   | 2 PC |
| 7    | TAPE POLYIMIDE FILM 1/2" X 36 YDS     | 79900-2048  | A/R  |
| 6    | FINAL PLUG ASSY. SING 1394B BILINGUAL | 449711001   | 2 PC |
| 5    | BACK SHELL HERMAPHRODITIC             | 446770001   | 4 PC |
| 4    | CABLE IEEE1394 (AWG25_4.6MM)          | 79923-2143  | A/R  |
| 3    | PVC 15% MF GREY UL94V-2               | 899920424   | A/R  |
| 2    | SHRINK TUB, 3/16" UL/VW-1/CSA MARKED  | 79941-1245  | A/R  |
| 1    | VINYL TAPE 1/4" BLACK                 | 79900-2049  | A/R  |

|  |                 |                                       |       |   |                     |   |                           |
|--|-----------------|---------------------------------------|-------|---|---------------------|---|---------------------------|
| RELEASED<br>EC NO: MEX2005-0039<br>DRWN: SALBA 2004/10/12<br>CHKD: 2004/10/13<br>APPR: GVILLAGR 2004/10/14 | QUALITY SYMBOLS | GENERAL TOLERANCES (UNLESS SPECIFIED) |       | SCALE 4:1   | DESIGN UNITS METRIC | THIRD ANGLE PROJECTION  | REVISE ON CAD ONLY        |
|  | <br>-0<br>C=0   |                                       |       | DIMENSION STYLE MM ONLY   |                     | TITLE<br><b>HARNESS ASSEMBLY</b><br><b>BETA TO BETA KEYING</b><br><b>4.5 METERS (25 AWG WIRE)</b> |                           |
|  |                 | 4 PLACES                              | ± --- | ± ---   | DRAWN BY            |   |                           |
|  |                 | 3 PLACES                              | ± --- | ± ---   | ECONTRER            | 10/10/2003  |                           |
| ANGULAR ±1/2°  |                 | 2 PLACES                              | ± --- | ± ---   | CHECKED BY          | DATE  | <b>MOLEX INCORPORATED</b> |
| DRAFT WHERE APPLICABLE   |                 | 1 PLACE                               | ± --- | ± ---   | ECONTRER            | 10/10/2003  |                           |
| MUST REMAIN WITHIN DIMENSIONS  |                 |                                       |       | APPROVED BY   | DATE                | MATERIAL NO.  | DOCUMENT NO.              |
|  |                 |                                       |       | JGUERRER  | 10/10/2003          | 446100001   | SD-44610-001              |
|  |                 |                                       |       | THIS DRAWING CONTAINS INFORMATION THAT IS PROPRIETARY TO MOLEX INCORPORATED AND SHOULD NOT BE USED WITHOUT WRITTEN PERMISSION |                     | SHEET NO.   | 1 OF 1                    |

5

4

3

2

1