

PART NAME: KNOB SCALE: 1:1 DATE: 9/19/90 DR. BY HD

THIS DRAWING IS THE PROPERTY OF DAVIES MOLDING COMPANY, IS SUBMITTED SOLELY AS A DESIGN OR ENGINEERING PROJECT. WE ACCEPT NO RESPONSIBILITY WHATSOEVER FOR THE PRACTICAL APPLICATION OF THE PIECES MADE TO THIS DESIGN.



DESIGNERS & MANUFACTURERS OF KNOBS, HANDLES, CASES & CUSTOM PLASTIC COMPONENTS

P/N	4232
M NO.	73
CAVITY	4232
CAVITY PLUG	4232-3
CORE	4230
CORE BUSHING	4230
SLEEVE BUSHING	4230
SLEEVE	4230
PIN BUSHING	4230-Y
OUTER PIN	4230-1
INNER PIN	4232
INSERT	11334

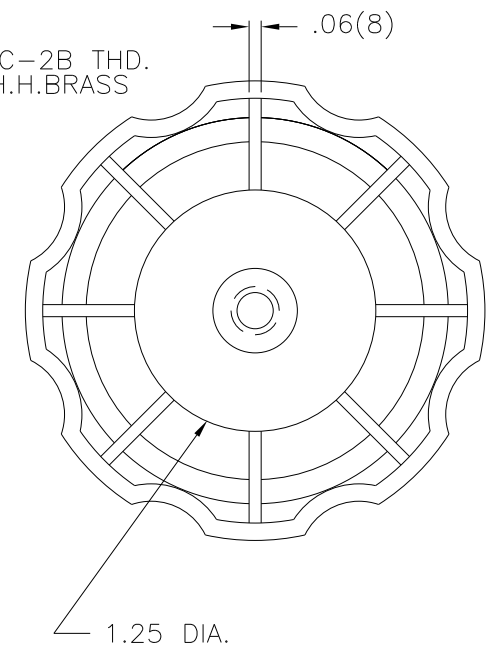
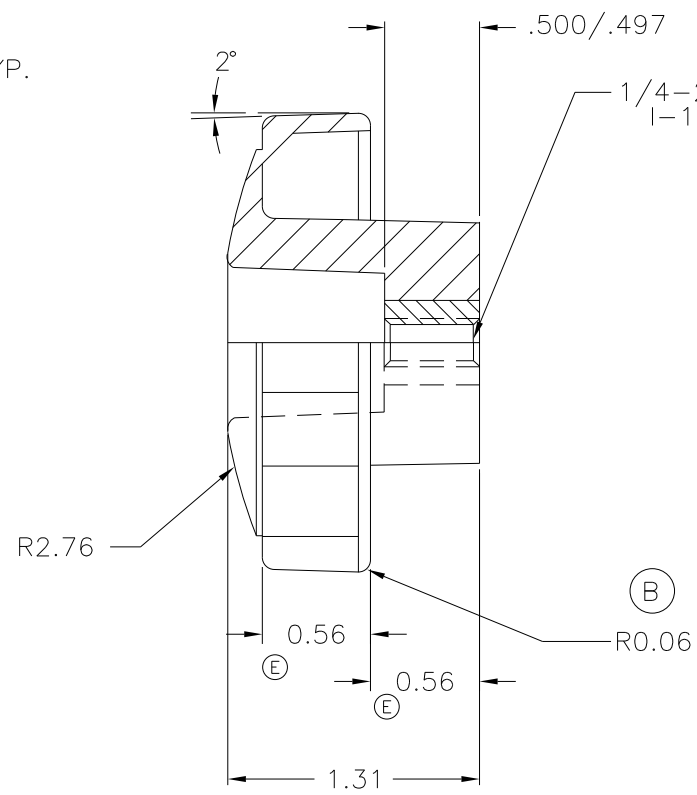
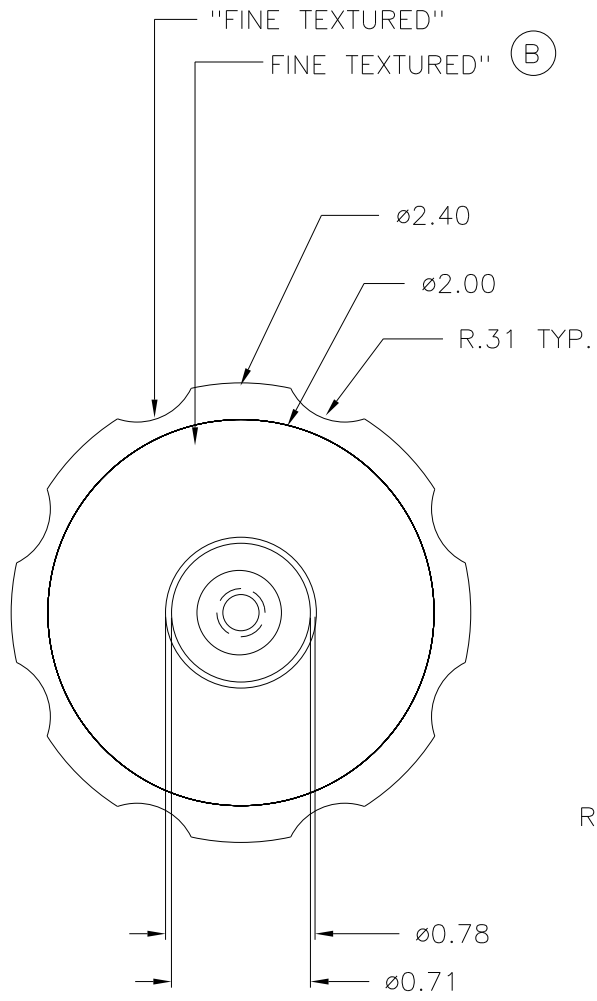

MATERIAL : 20% TALC POLYPROPYLENE (C)
 COLOR : BLACK

TOLERANCES: UNLESS OTHERWISE SPECIFIED	DO NOT SCALE DRAWING
DECIMALS: X.XXX ± .005 X.XX ± .015	MM: X.XX ± 0.15MM X.X ± 0.4MM
FRACTIONS ± 1/64	ANG. ± 1°

E	UPDATED DIMENSIONS TO MATCH TOOLING	JAM	11/26/01
D	UPDATED TOOLBOX	JAM	10/15/01
C	WAS POLYPRO.	HD	5/8/98
B	TEXTURED WAS RE-6225, RE-6310, AND R0.06 ADDED	HD	1/2/98
A	CAV.PLUG REVI.	HD	5/8/93
-	CAD/REDRAWN	HD	7/27/92

CHANGES