

OHOTA 400 x 400 product brief



Medical Image Sensor for Endoscopes and Catheters Improves Image Quality and Reduces Power Consumption



available in
a lead-free
package

OmniVision's OHOTA is an OVMed™ medical grade image sensor with a package size of just 0.55 mm x 0.55 mm, featuring a 1.0 micron pixel and a 1/31" optical format. The OHOTA takes medical visualization to the next level by quadrupling the RGB image resolution of its predecessor to 400 x 400, or 160 Kpixels, at 30 frames per second, while reducing the power consumption by 20% to 20 mW. This allows designers to add ultra-compact visualization to single-use and reusable endoscopes, as well as catheters and guidewires, with a small outer diameter of 1-2 mm.

The OHOTA's increased resolution improves the visualization of tissues and other fine details inside the human body, allowing surgeons to see crisper images during procedures such as neuro, ophthalmic, ENT, cardiac, spinal, urology, gynecology and arthroscopy, as well as dental and veterinary diagnosis and surgery. Additionally, the sensor's lower power consumption reduces "chip on tip" camera heat for greater patient comfort and longer procedure durations, while reducing noise.

To achieve this increase in resolution, along with a smaller pixel size and optical format, the OHOTA is built on OmniVision's PureCel™Plus-S stacked die technology. This next-generation pixel technology also provides higher color fidelity and excellent low light sensitivity of 3600 mV/lux-sec, along with a high signal-to-noise ratio of 37.5 dB for greater image quality. Additionally, PureCel™Plus-S enables the OHOTA's higher full well capacity (FWC), zero blooming and lower power consumption, resulting in better patient outcomes.

Other key features include a 15.5 degree chief ray angle, enabling the use of lenses with high fields of view and short focus distances. It also supports a 4-wire interface, as well as raw analog data output, both of which can transmit via cables as long as 4 meters with minimal signal noise. The OHOTA sensor also interfaces with OmniVision's existing OV426 analog-to-digital-conversion bridge chip for backward compatibility and easy adoption. Additionally, it is autoclavable for reusable endoscope sterilization.

Find out more at www.ovt.com.



OmniVision.

Applications

- Medical Endoscopes
- Medical and Dental Equipment
- Catheters
- Robotic Surgery
- Guidewires

Product Features

- optical size of 1/31"
- analog output
- single 3.3V power supply
- on-chip PLL
- serial peripheral interface (SPI)
- exposure and gain control
- pseudo-global shutter (LED mode)
- PureCel[®]Plus-S pixel structure
- improved sensitivity, FWC, zero blooming, low noise, and low power consumption
- enhanced NIR sensitivity
- square aspect ratio
- minimum package size (total 4 pads)
- autoclavable
- 4 m drive distance

OHOTA



Ordering Information

- OHOTA10-A04A (color, lead-free)
4-pin CSP

Technical Specifications

- active array size: 400 x 400
- frame rate:
- 160 Kpixel (400x400): 30 fps
- power supply:
- analog: 3.3V ±5%
- temperature range:
- operating: -20°C to +70°C junction temperature
- stable image: 0°C to +50°C junction temperature
- output format: analog signal output
- optical size: 1/31"
- lens chief ray angle:
supports lens up to 15° CRA
- scan mode: progressive
- color mosaic: RGB Bayer pattern
- pixel size: 1.008 μm x 1.008 μm
- image area: 411.264 μm x 411.264 μm
- package dimensions: 550 μm x 550 μm

Functional Block Diagram

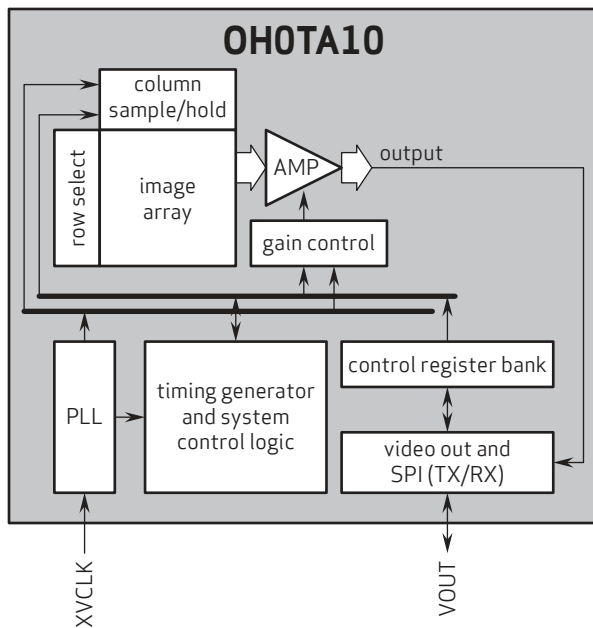

4275 Burton Drive
Santa Clara, CA 95054
USA

Tel: +1 408 567 3000
Fax: +1 408 567 3001
www.ovt.com

OmniVision reserves the right to make changes to their products or to discontinue any product or service without further notice. OmniVision, the OmniVision logo, OVMed, and PureCel are registered trademarks of OmniVision Technologies, Inc. All other trademarks are the property of their respective owners.



OmniVision