

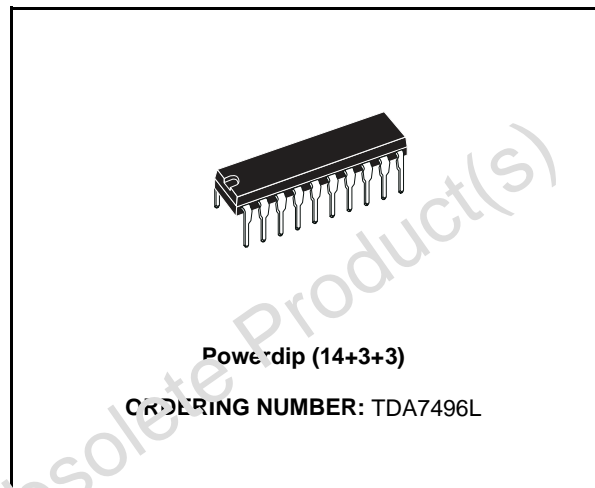

2W+2W AMPLIFIER WITH DC VOLUME CONTROL

- 2W+2W OUTPUT POWER
 $R_L = 8\Omega @THD = 10\% V_{CC} = 14V$
- ST-BY AND MUTE FUNCTIONS
- LOW TURN-ON TURN-OFF POP NOISE
- LINEAR VOLUME CONTROL DC COUPLED WITH POWER OP. AMP.
- NO BOUCHEROT CELL
- NO ST-BY RC INPUT NETWORK
- SINGLE SUPPLY RANGING UP TO 15V
- SHORT CIRCUIT PROTECTION
- THERMAL OVERLOAD PROTECTION
- INTERNALLY FIXED GAIN
- SOFT CLIPPING
- VARIABLE OUTPUT AFTER VOLUME CONTROL CIRCUIT
- POWERDIP (14+3+3) PACKAGE



DESCRIPTION

The TDA7496L is a stereo 2W+2W class AB power amplifier assembled in the @ Powerdip

14+3+3 package, specially designed for high quality sound, TV and Monitor applications.

Features of the TDA7496L include linear volume control, Stand-by and mute functions.

BLOCK DIAGRAM

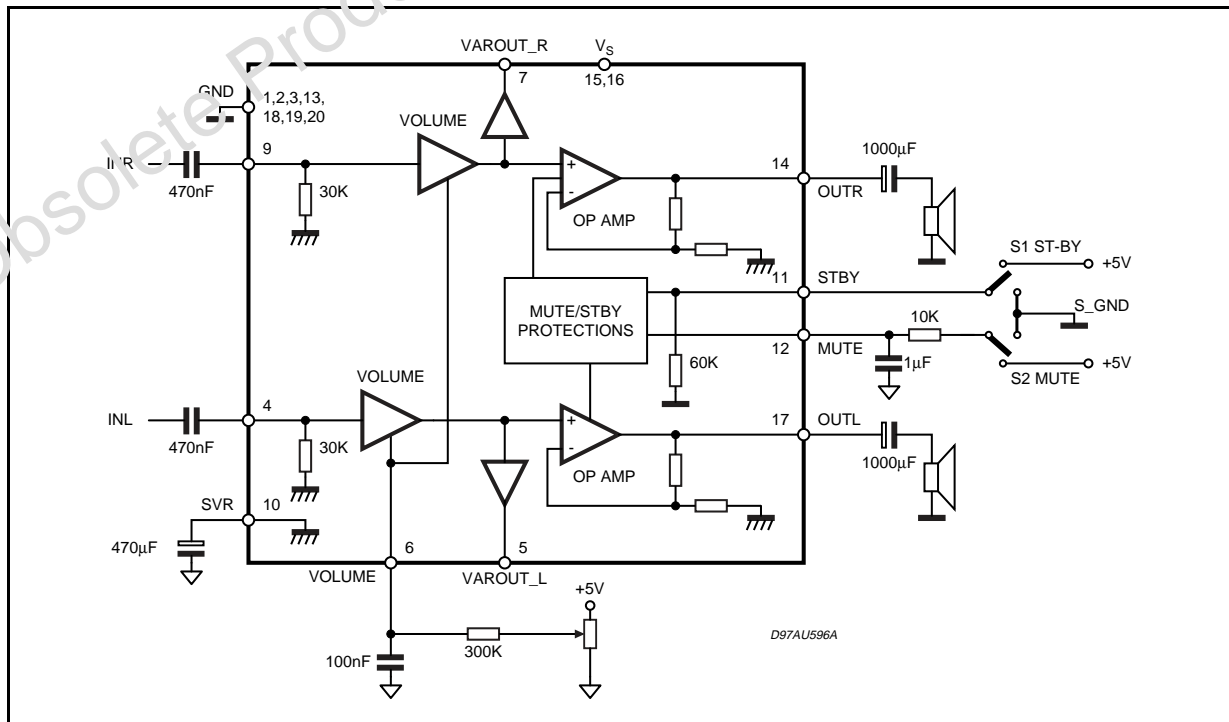

ABSOLUTE MAXIMUM RATINGS

Symbol	Parameter	Value	Unit
V _S	DC Supply Voltage	26	V
V _{IN}	Maximum Input Voltage	8	V _{pp}
P _{tot}	Total Power Dissipation (T _{case} = 60°C)	6	W
T _{amb}	Ambient Operating Temperature	0 to 70	°C
T _{stg} , T _j	Storage and Junction Temperature	-40 to 150	°C
V ₆	Volume CTRL DC voltage	7	V

PIN CONNECTION

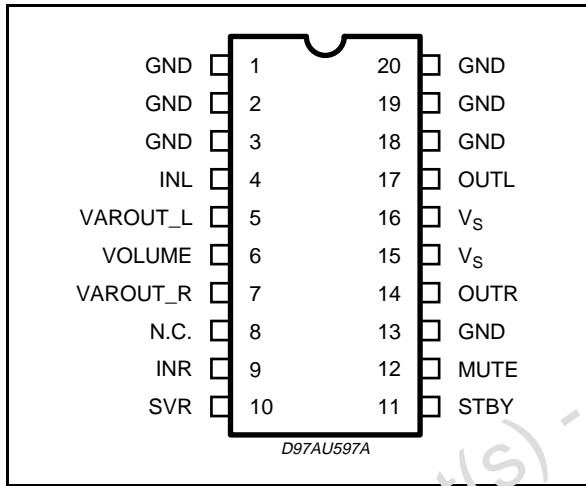

R_{th} with "on board" Square Heatsink vs. copper area.

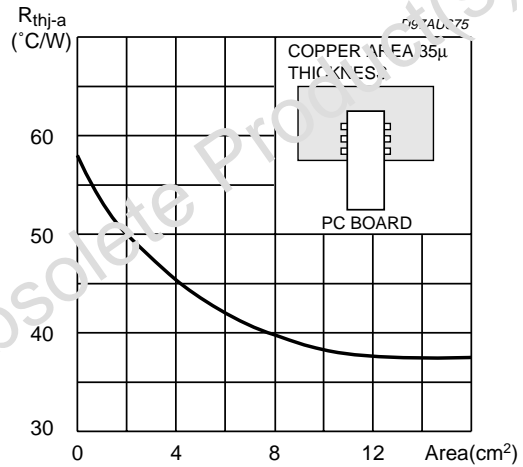

THERMAL DATA

Symbol	Parameter	Value	Unit
R _{th j-pins}	Thermal Resistance Junction-pins	max. 15	°C/W
R _{th j-amb} (*)	Thermal Resistance Junction-ambient	max. 50	°C/W

(*) Mounted on PCB with no heatsink

ELECTRICAL CHARACTERISTICS (Refer to the test circuit V_S = 14V; R_L = 8Ω, R_g = 50Ω, T_{amb} = 25°C).

Symbol	Parameter	Test Condition	Min.	Typ.	Max.	Unit
V _s	Supply Voltage Range		10		18	V
I _q	Total Quiescent Current			25	50	mA
DCVos	Output DC Offset Referred to SVR Potential	No Input Signal		200		mV
V _o	Quiescent Output Voltage			7		V
P _o	Output Power	THD = 10%; R _L = 8Ω; THD = 1%; R _L = 8Ω;	1.6	2		W
THD	Total Harmonic Distortion	G _v = 30dB; P _o = 1W; f = 1KHz;			0.4	%
I _{peak}	Output Peak Current	(internally limited)	0.7	0.9		A
V _{in}	Input Signal				2.8	V _{rms}
G _v	Closed Loop Gain	Vol Ctrl > 4.5V	28.5	30	31.5	dB
G _{vLine}	Monitor Out Gain	Vol Ctrl > 4.5V; Zload > 30KΩ	-1.5	0	1.5	dB
A _{Min VOL}	Attenuation at Minimum Volume	Vol Ctrl < 0.5V	80			dB
BW				0.6		MHz

ELECTRICAL CHARACTERISTICS (continued)

Symbol	Parameter	Test Condition	Min.	Typ.	Max.	Unit
en	Total Output Noise	f = 20Hz to 22KHz Play, max volume		500	800	μV
		f = 20Hz to 22KHz Play, max attenuation		100	250	μV
		f = 20Hz to 22KHz Mute		60	150	μV
SR	Slew Rate		5	8		V/ μs
R _i	Input Resistance		22.5	30		K Ω
R _{Var Out}	Variable Output Resistance			30	100	Ω
R _{load Var Out}	Variable Output Load		2			K Ω
SVR	Supply Voltage Rejection	f = 1kHz; max volume C _{SVR} = 470 μF ; V _{RIP} = 1V _{rms}	35	39		α3
		f = 1kHz; max attenuation C _{SVR} = 470 μF ; V _{RIP} = 1V _{rms}	55	65		dB
T _M	Thermal Muting			150		$^{\circ}\text{C}$
T _s	Thermal Shut-down			160		$^{\circ}\text{C}$
MUTE STAND-BY & INPUT SELECTION FUNCTIONS						
V _{ST ON}	Stand-by ON Threshold		3.5			V
V _{ST OFF}	Stand-by OFF Threshold				1.5	V
V _{M ON}	Mute ON Threshold		3.5			V
V _{M OFF}	Mute OFF Threshold				1.5	V
I _{qST-BY}	Quiescent Current @ Stand-by			0.6	1	mA
A _{MUTE}	Mute Attenuation		50	65		dB
I _{stbyBIAS}	Stand-by bias current	Stand by on V _{ST-BY} = 5V V _{MUTE} = 5V		80		μA
		Play or Mute	-20	-5		μA
I _{muteBIAS}	Mute bias current	Mute		1	5	μA
		Play		0.2	2	μA

APPLICATION SUGGESTIONS

The recommended values of the external components are those shown on the application circuit of figure 1A. Different values can be used, the following table can help the designer.

COMPONENT	SUGGESTION VALUE	PURPOSE	LARGER THAN SUGGESTION	SMALLER THAN SUGGESTION
R ₁	300K	Volume control circuit	Larger volume regulation time	Smaller volume regulation time
R ₂	10K	Mute time constant	Larger mute on/off time	Smaller mute on/off time
P ₁	50K	Volume control circuit		
C ₁	1000 μF	Supply voltage bypass		Danger of oscillation
C ₂	470nF	Input DC decoupling	Lower low frequency cutoff	Higher low frequency cutoff
C ₃	470nF	Input DC decoupling	Lower low frequency cutoff	Higher low frequency cutoff
C ₄	470 μF	Ripple rejection	Better SVR	Worse SVR
C ₅	100nF	Volume control time constant	Larger volume regulation time	Smaller volume regulation time
C ₆	1000 μF	Output DC decoupling	Lower low frequency cutoff	Higher low frequency cutoff
C ₇	1 μF	Mute time constant	Larger mute on/off time	Smaller mute on/off time
C ₈	1000 μF	Output DC decoupling	Lower low frequency cutoff	Higher low frequency cutoff
C ₉	100nF	Supply voltage bypass		Danger of oscillation

Figure 1A. Application Circuit.

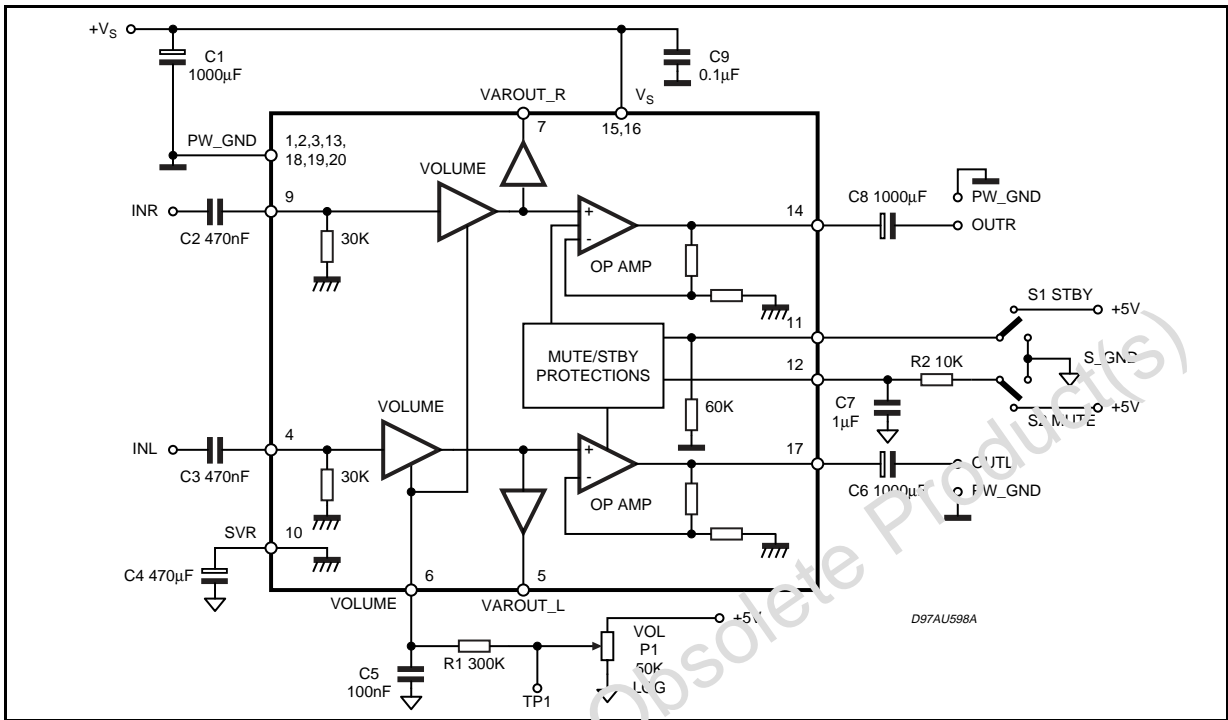
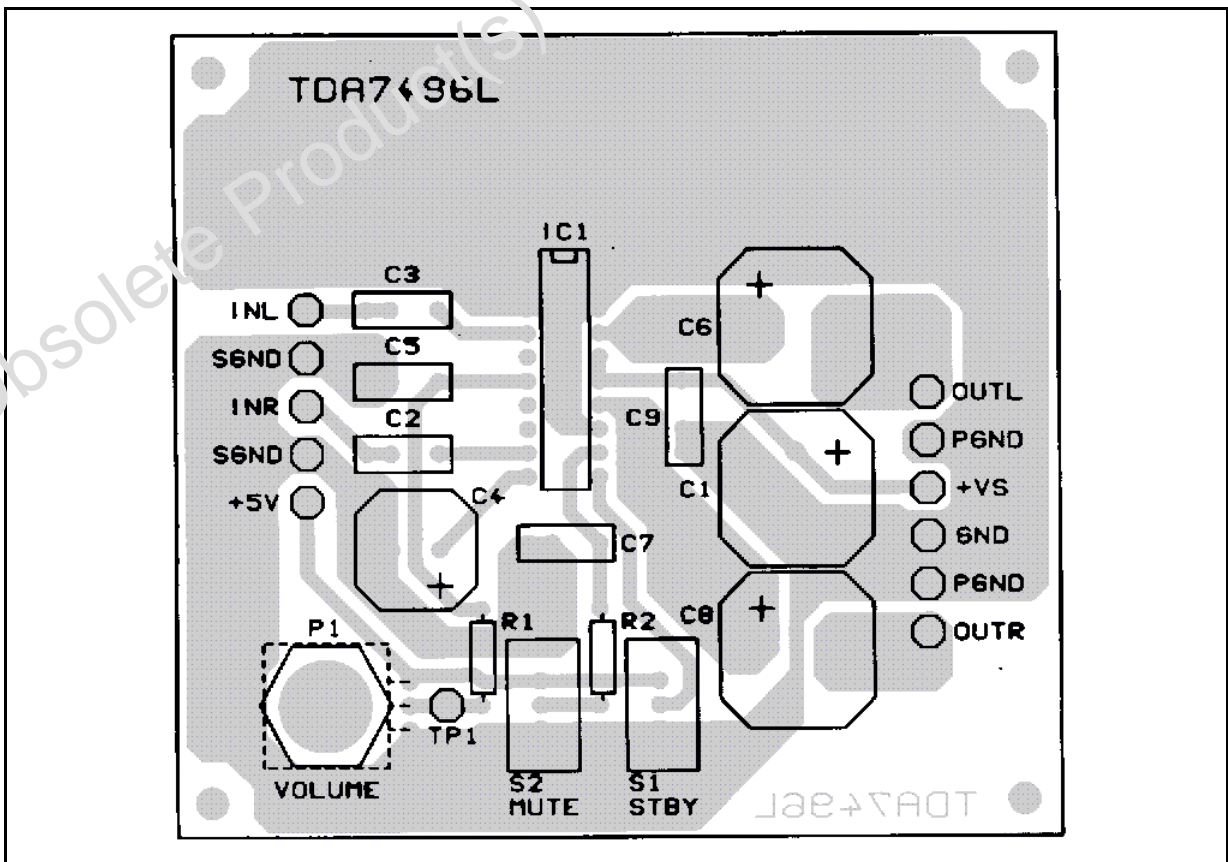

Figure 1B. PCB and Component Layout of the Fig. 1A (1.25:1 scale)



MUTE STAND-BY TRUTH TABLE

MUTE	ST-BY	OPERATING CONDITION
H	H	STANDBY
L	H	STANDBY
H	L	MUTE
L	L	PLAY

Turn ON/OFF Sequences (for optimizing the POP performances)

A) USING MUTE AND STAND-BY FUNCTIONS

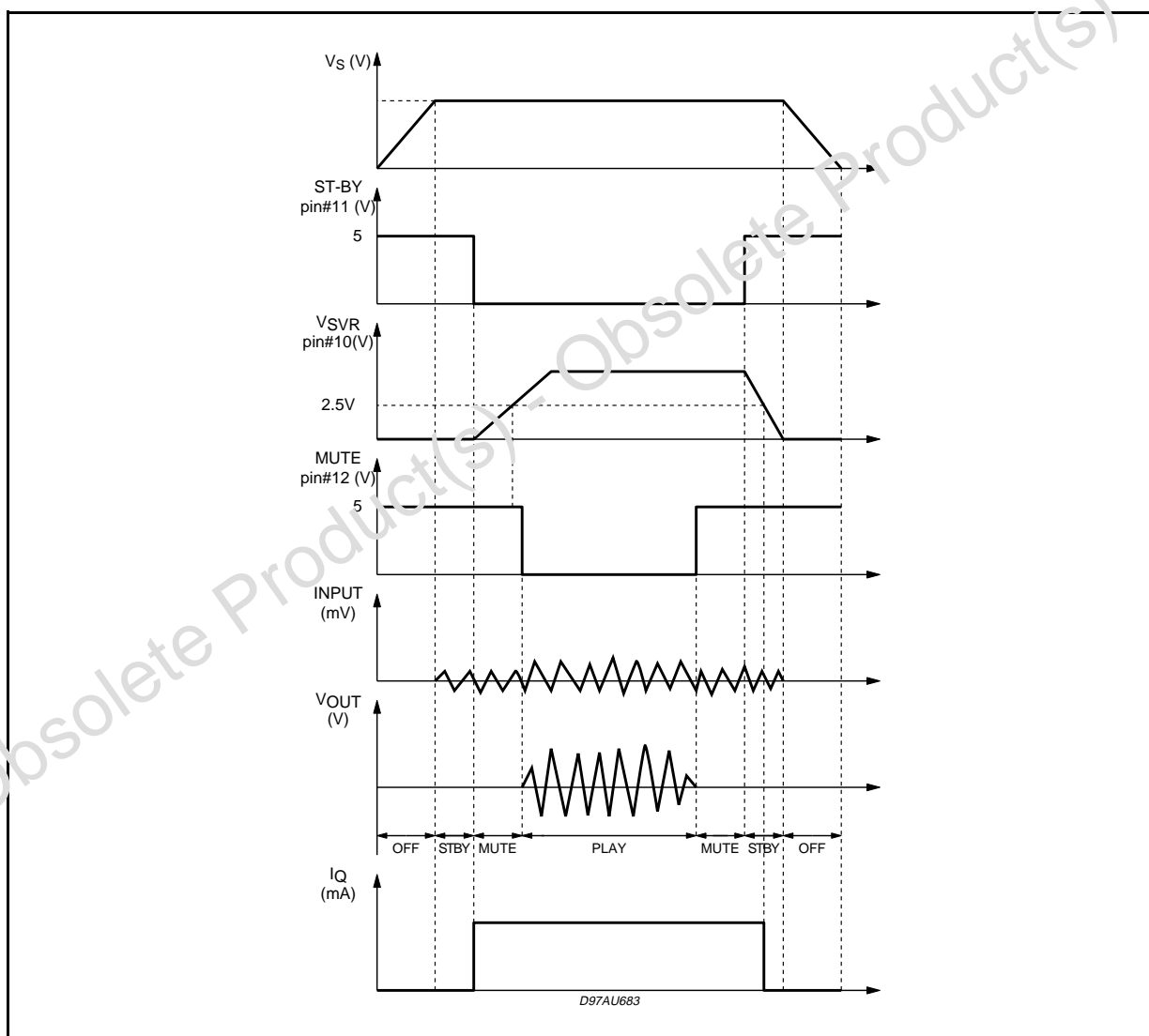

B) USING ONLY THE MUTE FUNCTION

To simplify the application, the stand-by pin can be connected directly to Ground.

During the ON/OFF transitions it is recommended to respect the following conditions.

- At the turn-on, the transition mute - play must be made when the SVR pin is higher than 2.5V
- At the turn-off, the TDA7496L must be brought to mute from the play condition when the SVR pin is higher than 2.5V.

Quiescent current vs. Supply Voltage

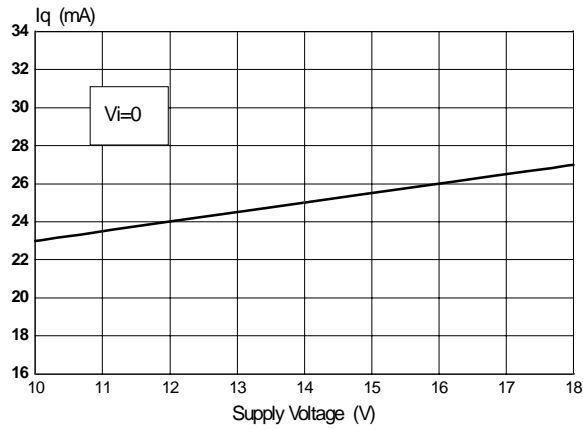

Output DC Voltage vs. Supply Voltage

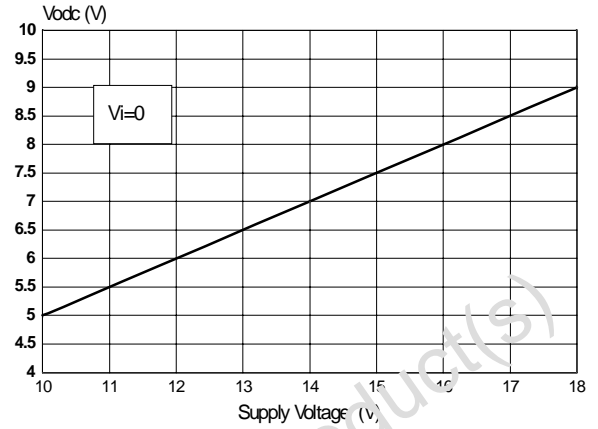

Output DC Offset vs. Supply Voltage

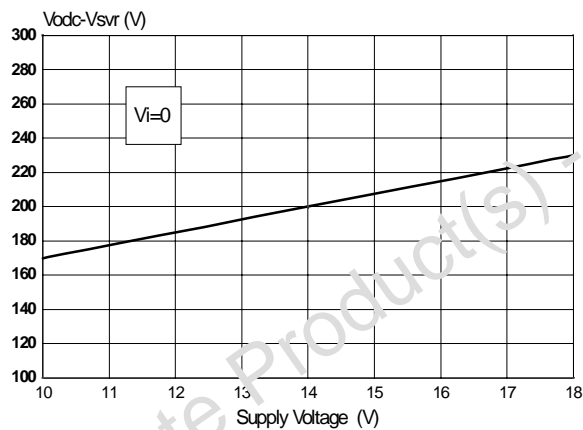

Output Power vs. Supply Voltage

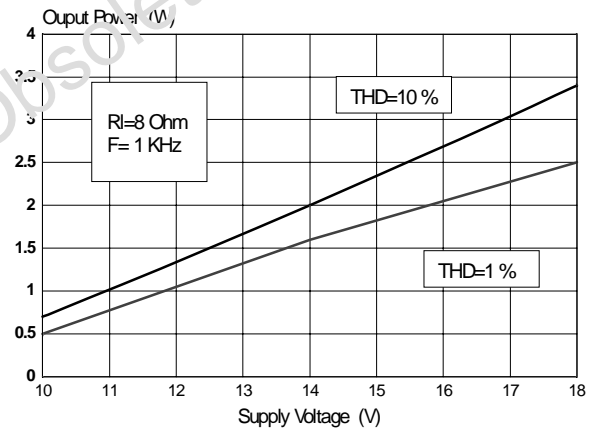

Distortion vs. Output Power

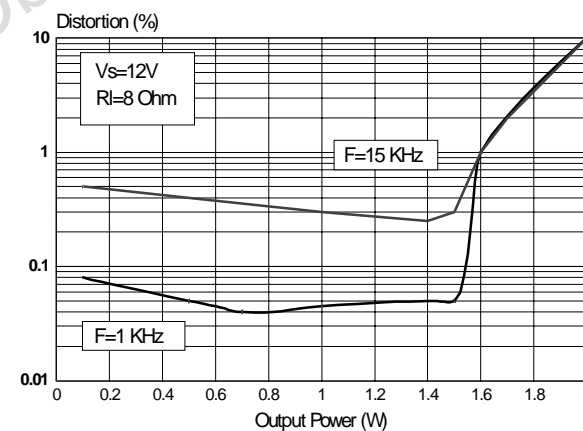

Closed Loop gain vs. Frequency

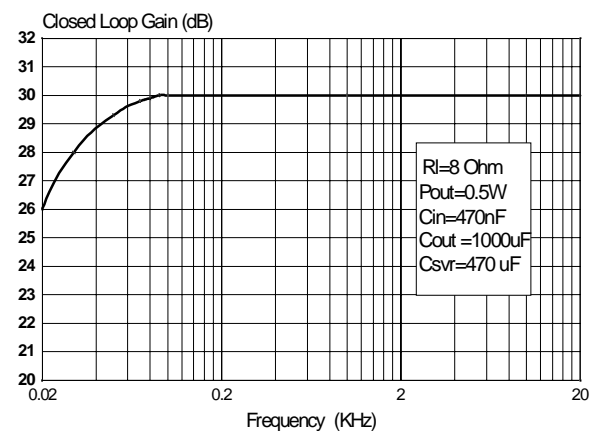

St-By Attenuation vs. Vpin 11

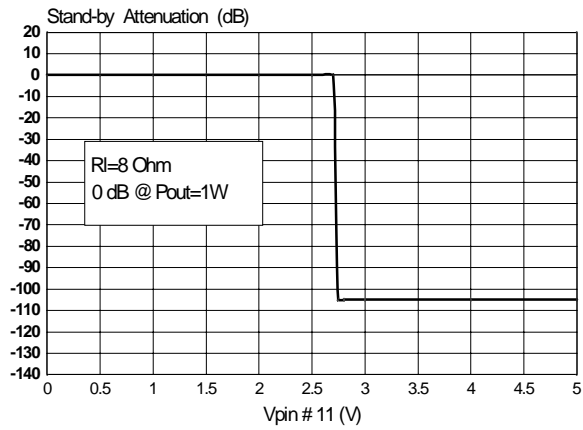

Mute Attenuation vs. Vpin 12

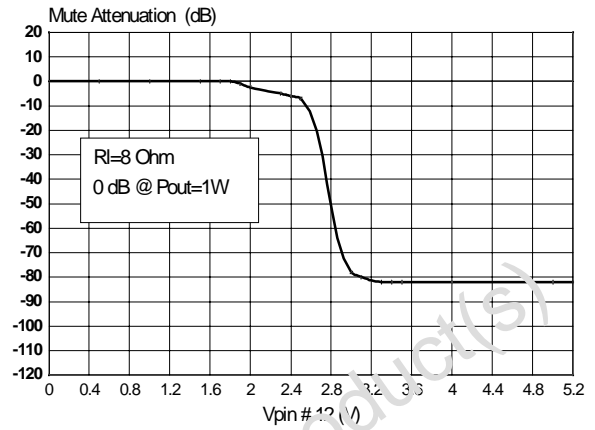

PIN DESCRIPTION

PIN: SVR

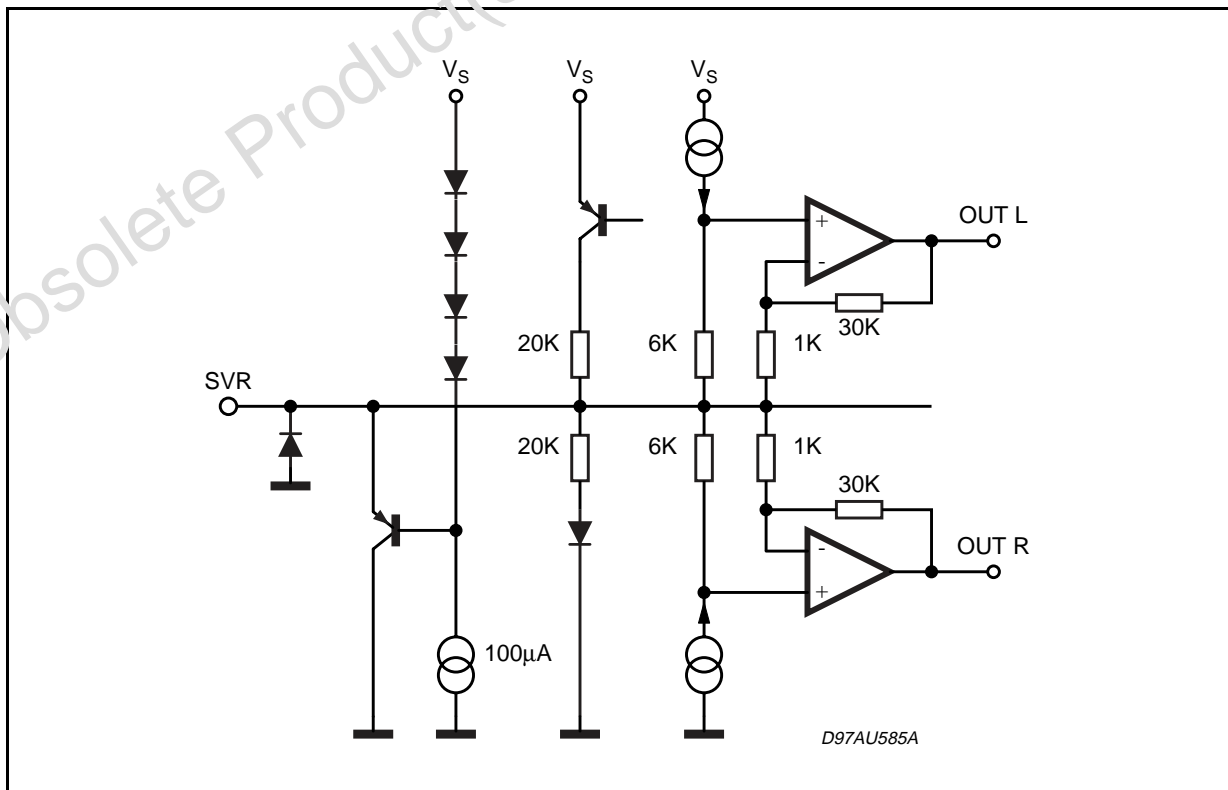

PINS: INL, INR

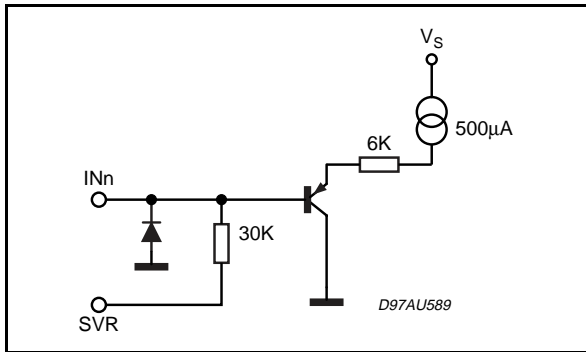

PINS: VAROUT-L, VAROUT-R

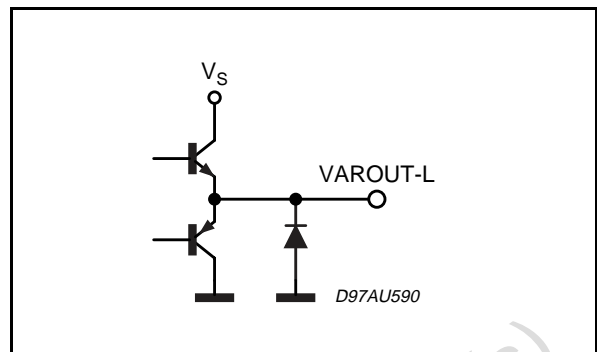

PIN: VOLUME

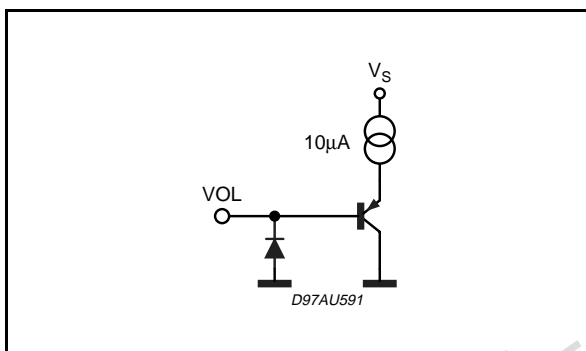

PIN: MUTE

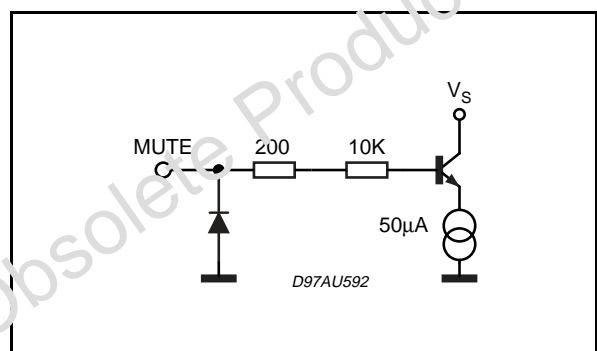

PINS: PW-GND, S-GND

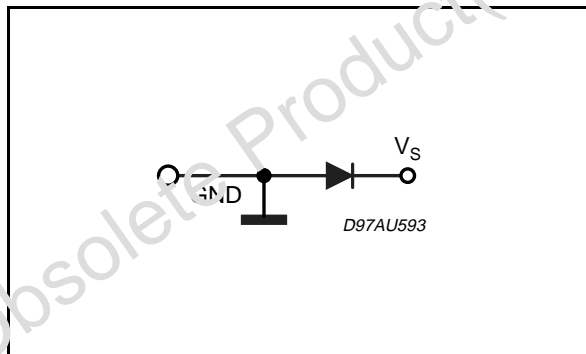

PINS: OUT R, OUT L

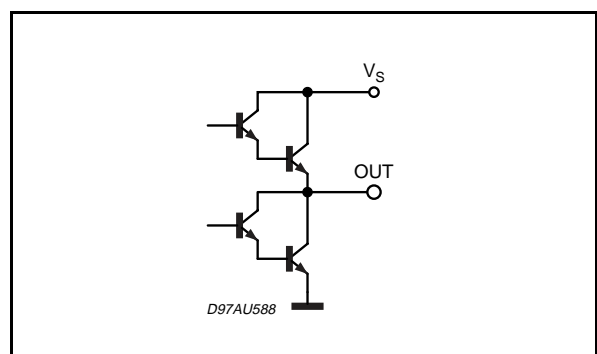

PIN: STBY

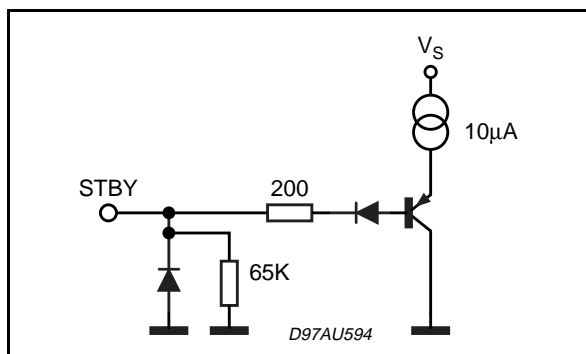

DIM.	mm			inch		
	MIN.	TYP.	MAX.	MIN.	TYP.	MAX.
a1	0.51			0.020		
B	0.85		1.40	0.033		0.055
b		0.50			0.020	
b1	0.38		0.50	0.015		0.020
D			24.80			0.976
E		8.80			0.346	
e		2.54			0.100	
e3		22.86			0.900	
F			7.10			0.280
I			5.10			0.201
L		3.30			0.130	
Z			1.27			0.050

OUTLINE AND MECHANICAL DATA

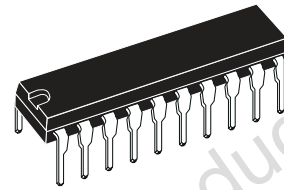

Powerdip 20

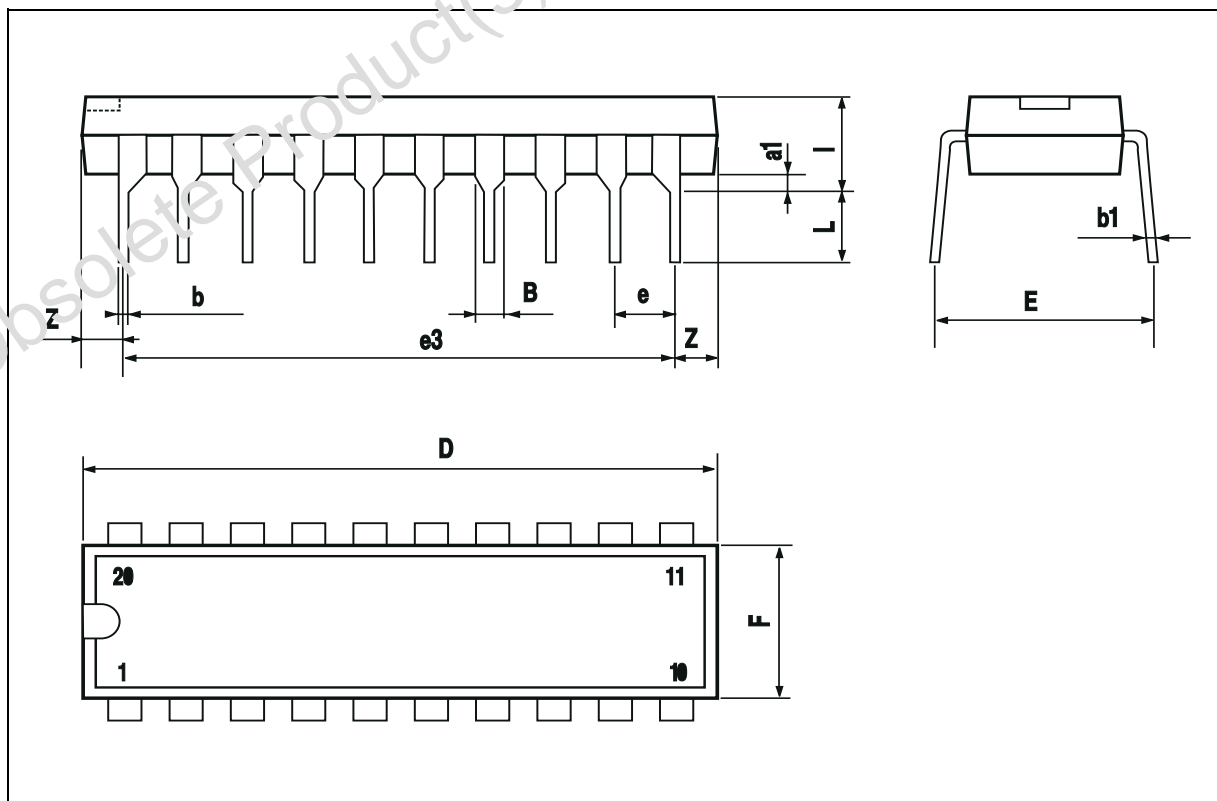

Obsolete Product(s) - Obsolete Product(s)

Information furnished is believed to be accurate and reliable. However, STMicroelectronics assumes no responsibility for the consequences of use of such information nor for any infringement of patents or other rights of third parties which may result from its use. No license is granted by implication or otherwise under any patent or patent rights of STMicroelectronics. Specifications mentioned in this publication are subject to change without notice. This publication supersedes and replaces all information previously supplied. STMicroelectronics products are not authorized for use as critical components in life support devices or systems without express written approval of STMicroelectronics.

The ST logo is a registered trademark of STMicroelectronics.
All other names are the property of their respective owners

© 2003 STMicroelectronics - All rights reserved

STMicroelectronics GROUP OF COMPANIES

Australia – Belgium - Brazil - Canada - China – Czech Republic - Finland - France - Germany - Hong Kong - India - Israel - Italy - Japan -
Malaysia - Malta - Morocco - Singapore - Spain - Sweden - Switzerland - United Kingdom - United States

www.st.com