

Instruction Manual

# 2WD Mobile Platform

## 安装说明书

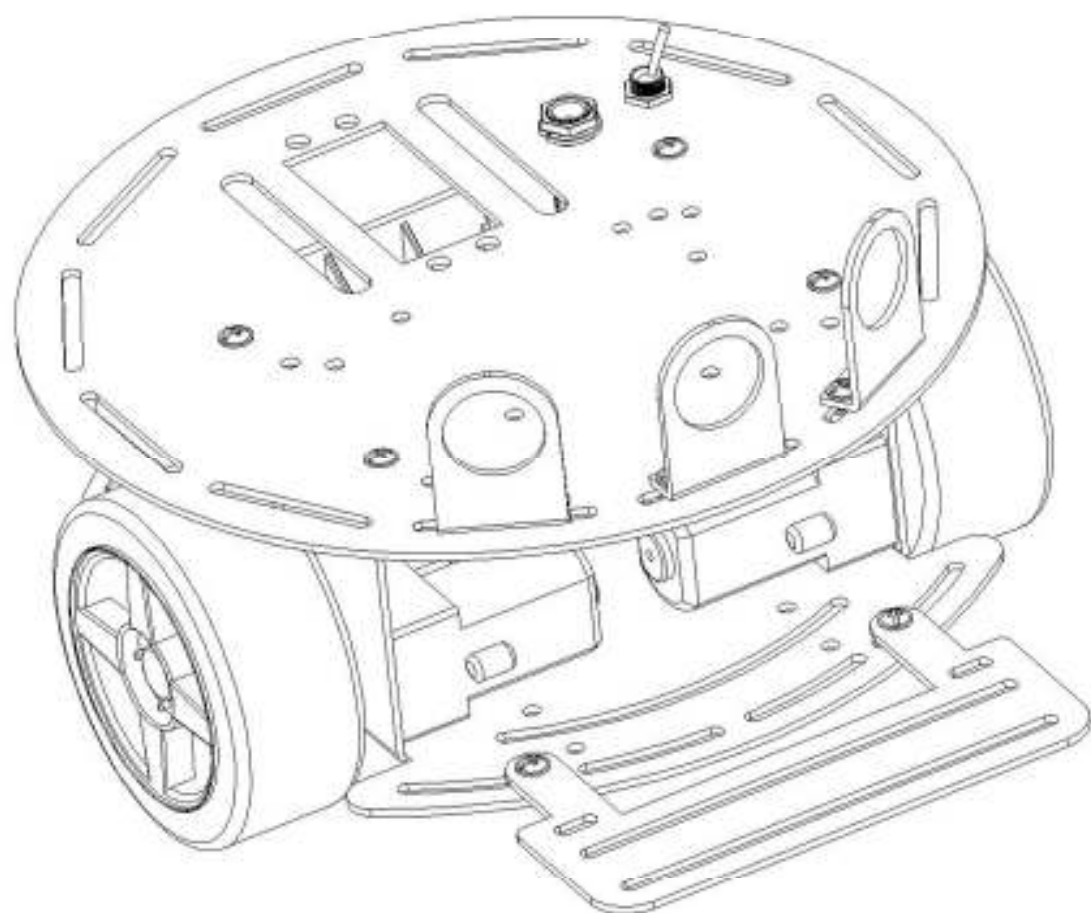

在使用2WD Mobile Platform之前，请仔细阅读此说明书。

Read the manual carefully before using 2WD Mobile Platform.

Ver 1.1

**DFROBOT**

DRIVE THE FUTURE

## 目录 Contents

产品特性	1-2
Features	
产品安装须知	3
Notice for Assembly	
底盘主要部件安装	4-5
Main Chassis Assembly	
底盘附件安装	6
Accessories for Chassis Assembly	
上盖部件安装	7-8
Upper Cover Assembly	
整机组装	9
Final Platform Assembly	
零部件清单	10
Parts List	

## 整机尺寸

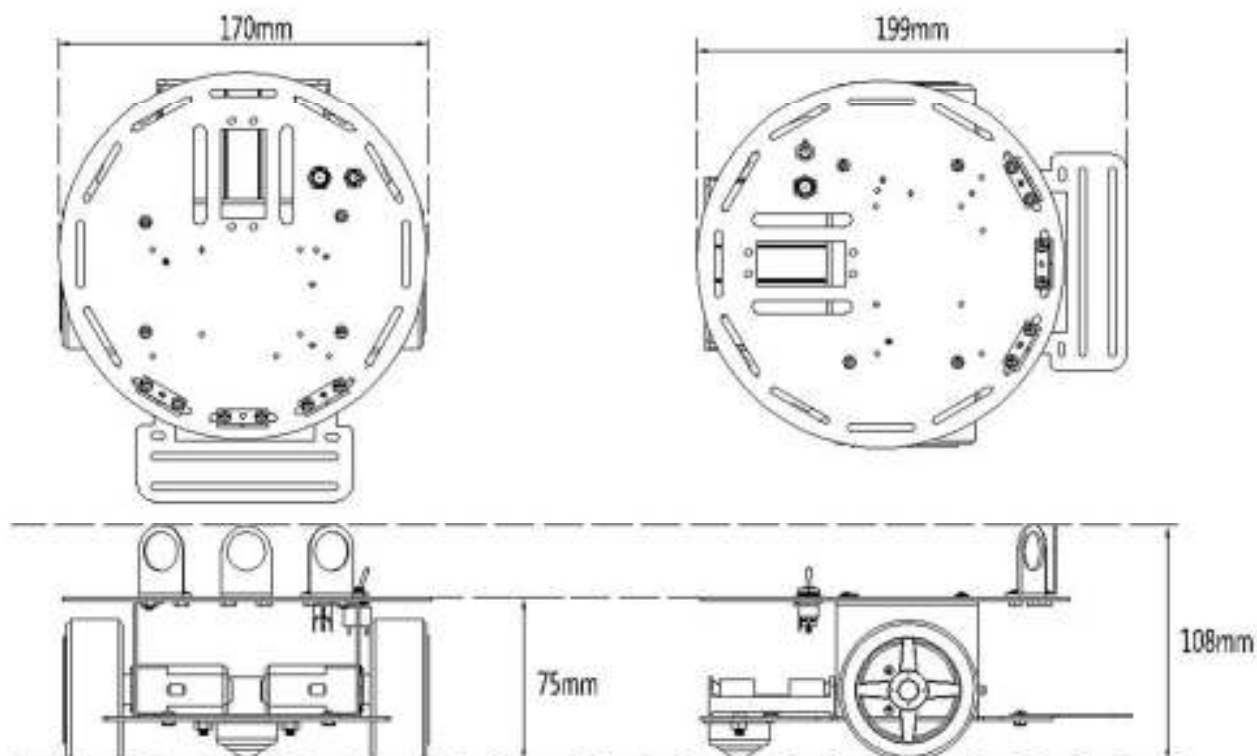

### 简介：

Arduino 2WD两轮驱动机器人是DFRobot研制的机器人实验平台，该平台不但可以用51控制、STC控制器、AVR控制器控制外，更适合使用世界上广泛推广的Arduino控制器，Arduino开放平台拥有全球众多使用者，有丰富的使用例子程序。2轮差速驱动，使用转弯半径趋近于零，机身采用高强度铝合金材料，高速电机加优质橡胶轮运动灵活快速。使用Arduino控制器编程简单，控制起来非常有趣。

整机重量：445克

车轮直径：65mm

最大行驶速度:61cm/s

### 电机参数：

- 电机供电电压：3-6V
- 无负载运行电流(3V):60mA
- 力矩(3V): 1.2Kgcm
- 减速比：1：120
- 无负载运行电流(6V):71mA
- 力矩(6V): 1.92Kgcm
- 无负载转速(3V):100RPM
- 堵转电流(3V):260mA
- 重量:45g
- 无负载转速(6V):200RPM
- 堵转电流(6V):470mA

## 产品特性 Features

### Dimensions

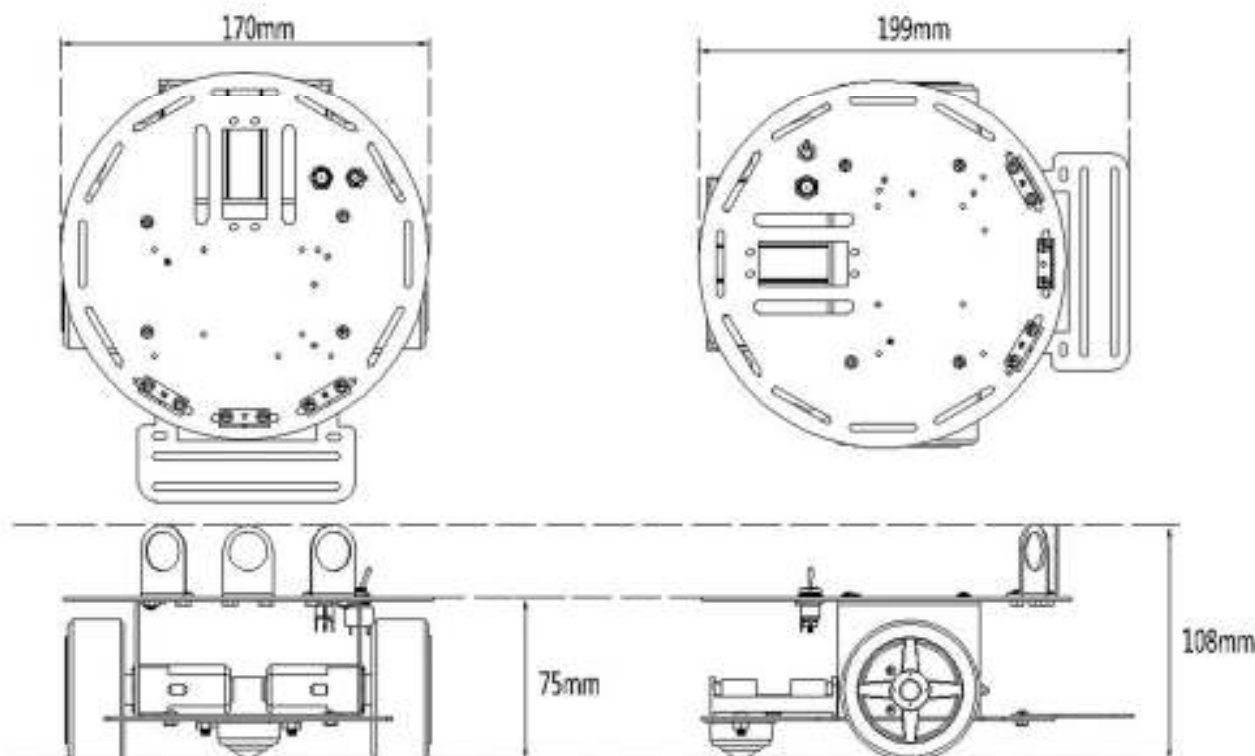

### Introduction :

The Arduino 2WD two-wheel-drive robot is a DFRobot original design and widely used as self-developed control panel for the Arduino platform. The platform can be controlled by a wide variety of microcontrollers including the widely popular Arduino. The Arduino platform has a large user base which provides a vast amount of resources and sample programs on the internet. The two differential drives, powered by high-quality high-speed motors and flexible rubber wheels are mounted on a high-strength aluminum alloy body. The motors provide a near zero turning radius. This robotic platform is suitable for indoor use or flat road surfaces.

Complete Machine Weight : 445g

Wheel Diameter: 65mm

Max Speed: 61cm/s

### Motor Specifications :

Gear Ratio: 1:120

No-load speed (3V): 100RPM

No-load speed (6V): 200RPM

No-load current (3V): 60mA

No-load current (6V): 71mA

Stall current (3V): 260mA

Stall current (6V): 470mA

Torgue (3V): 1.2Kgcm

Torque (6V): 1.92Kgcm

Weight: 45g

# 产品安装须知 Notice for Assembly

以下设备不包括在ROB0005的部件清单内，用户需自行配备：

1. 5节AA电池。
2. 控制器以及电机驱动器。
3. 编码器（可选装）。

您还需要准备以下工具，并参考零部件清单进行ROB0005的安装：

1. 十字螺丝刀（适用于M2.5，M3，M4的螺丝）。
2. 尖嘴钳。

The following parts are not included in the kit:

1. AA battery (5 pieces).
2. Micro-controller and Motor driver.
3. Encoder (optional).

When beginning assembly, prepare the tools below and pick out the parts from the Parts List:

1. Phillips screwdriver ( for screws of M2.5 , M3 , M4 ) .
2. Needle nose pliers.

## 标志含义 Symbol Definition

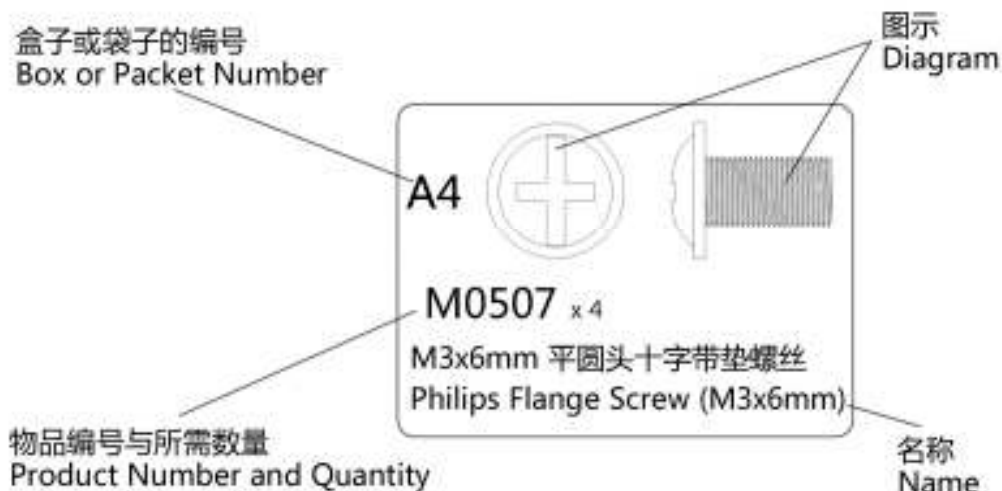

# 底盘主要部件安装(A) Main Chassis Assembly(A)

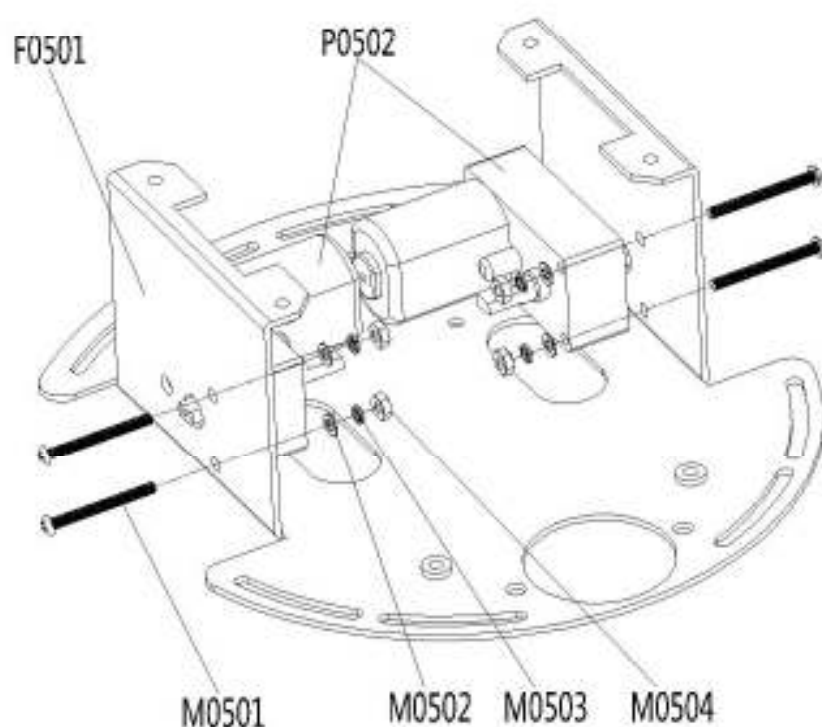

 <p><b>A4</b> M0501 x 4 M2.5x25mm 半圆头十字螺丝 Philips Truss Screw (M2.5x25mm)</p>	 <p><b>A4</b> M0502 x 4 M2.5垫片 M2.5 Washer</p>	 <p><b>A4</b> M0503 x 4 M2.5 弹簧垫圈 M2.5 Spring Washer</p>	 <p><b>A4</b> M0504 x 4 M2.5 螺母 M2.5 Nut</p>
--	---	--	---

## 底盘主要部件安装(B) Main Chassis Assembly(B)

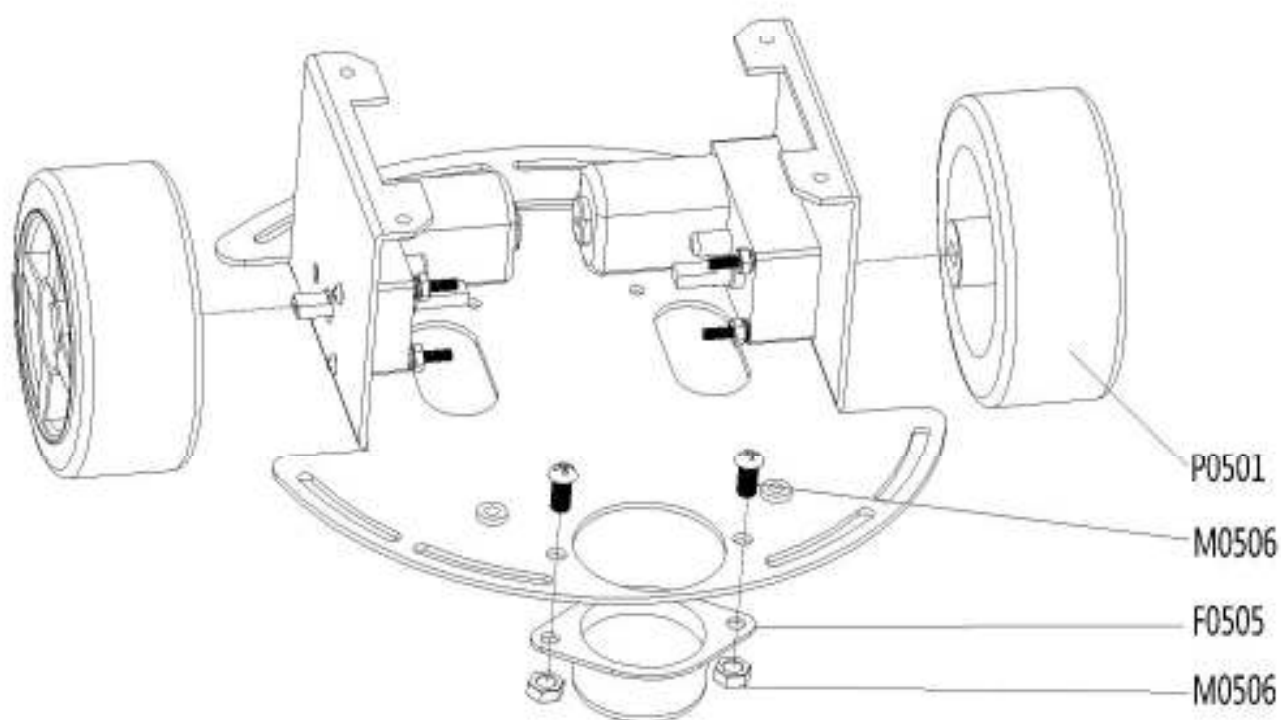

## 底盘附件安装 Accessories for Chassis Assembly



A1  
F0503

传感器支架  
Sensor Mounting Grill



A13  
P0503

电池盒  
Battery Holder

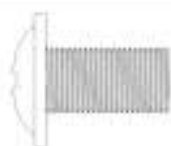
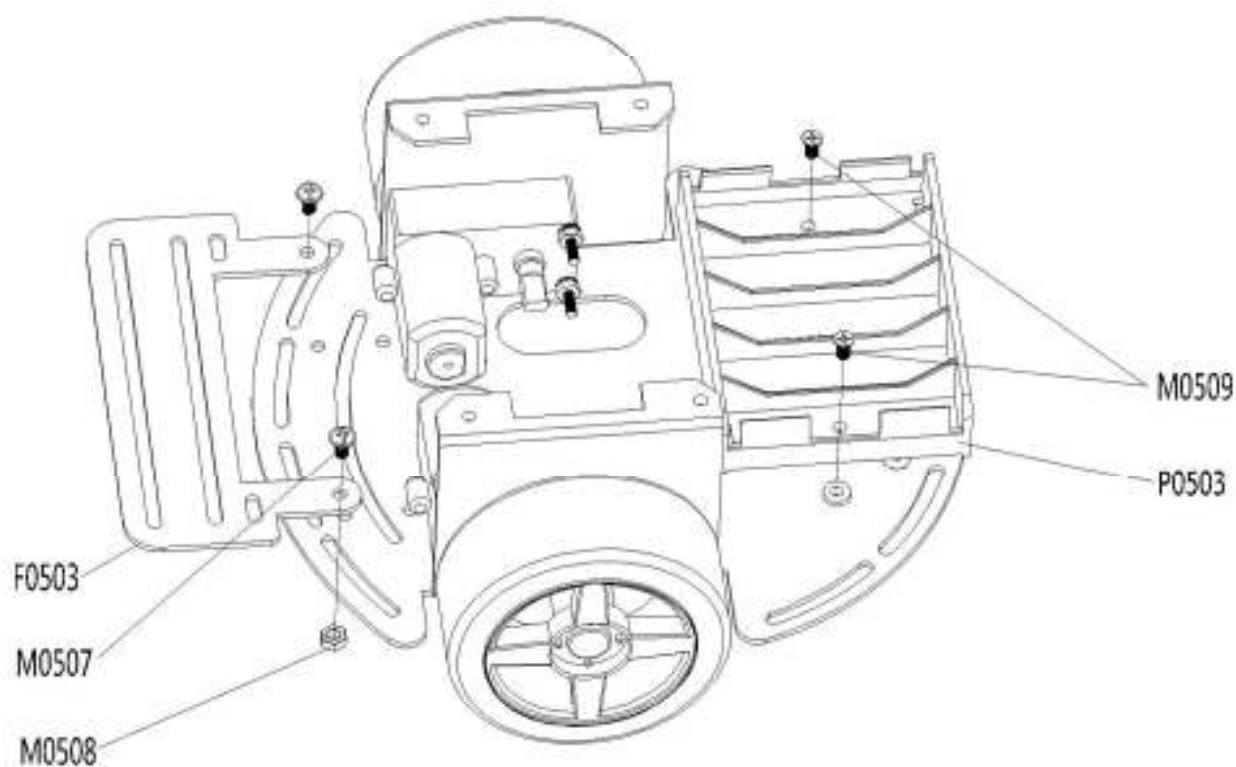

A6 M0507 x2  
M3x6mm 平圆头十字带垫螺丝  
Philips Flange Screw (M3x6mm)



A6 M0504 x2  
M3 螺母  
M3 Nut

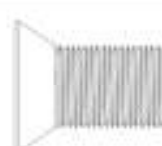

A7 M0509 x2  
M3x5mm 沉头十字螺丝  
Philips Countersunk Screw (M3x5mm)



# 上盖部件安装(A) Upper Cover Assembly(A)

 <p>A1 F0502 车身上板 Fuselage Upper Plate</p>	 <p>A9 M0513 x1 M8 螺母 M8 Nut</p>	 <p>A9 M0514 x1 M8 弹簧垫圈 M8 Spring Washer</p>	 <p>A9 M0515 x1 电源插口 Power Jack</p>
---	---	--	--

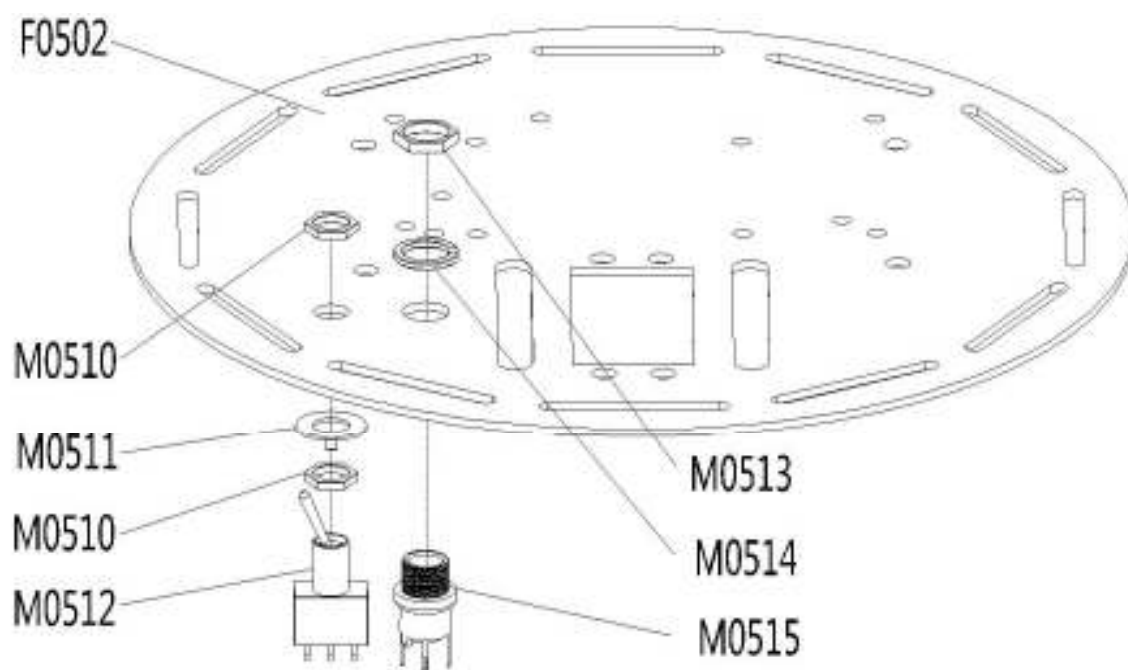

 <p>A8 M0510 x2 M6 螺母 M6 Nut</p>	 <p>A8 M0511 x1 M6 专用垫片 M6 Special Washer</p>	 <p>A8 M0512 x1 电源开关 Power Switch</p>
---	--	--

## 上盖部件安装(B) Upper Cover Assembly(B)

 <p>A2 F0504 x 3 红外传感器支架 IR Sensor Mounting Bracket</p>	 <p>A6 M0507 x 6 M3x6mm 平圆头十字带垫螺丝 Philips Flange Screw (M3x6mm)</p>	 <p>A6 M0504 x 6 M3 螺母 M3 Nut</p>
--	---	--

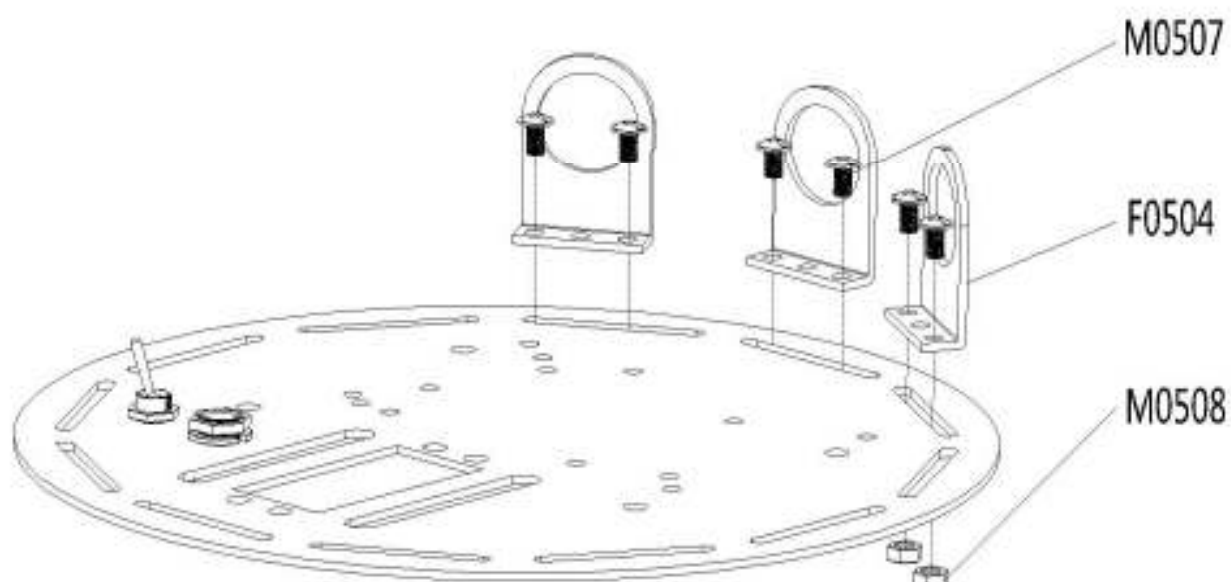

## 整机组装 Final Platform Assembly

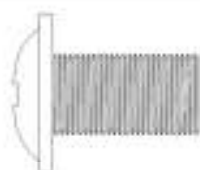

A6

M0507 x 4

M3x6mm 平圆头十字带垫螺丝

Philips Flange Screw (M3x6mm)

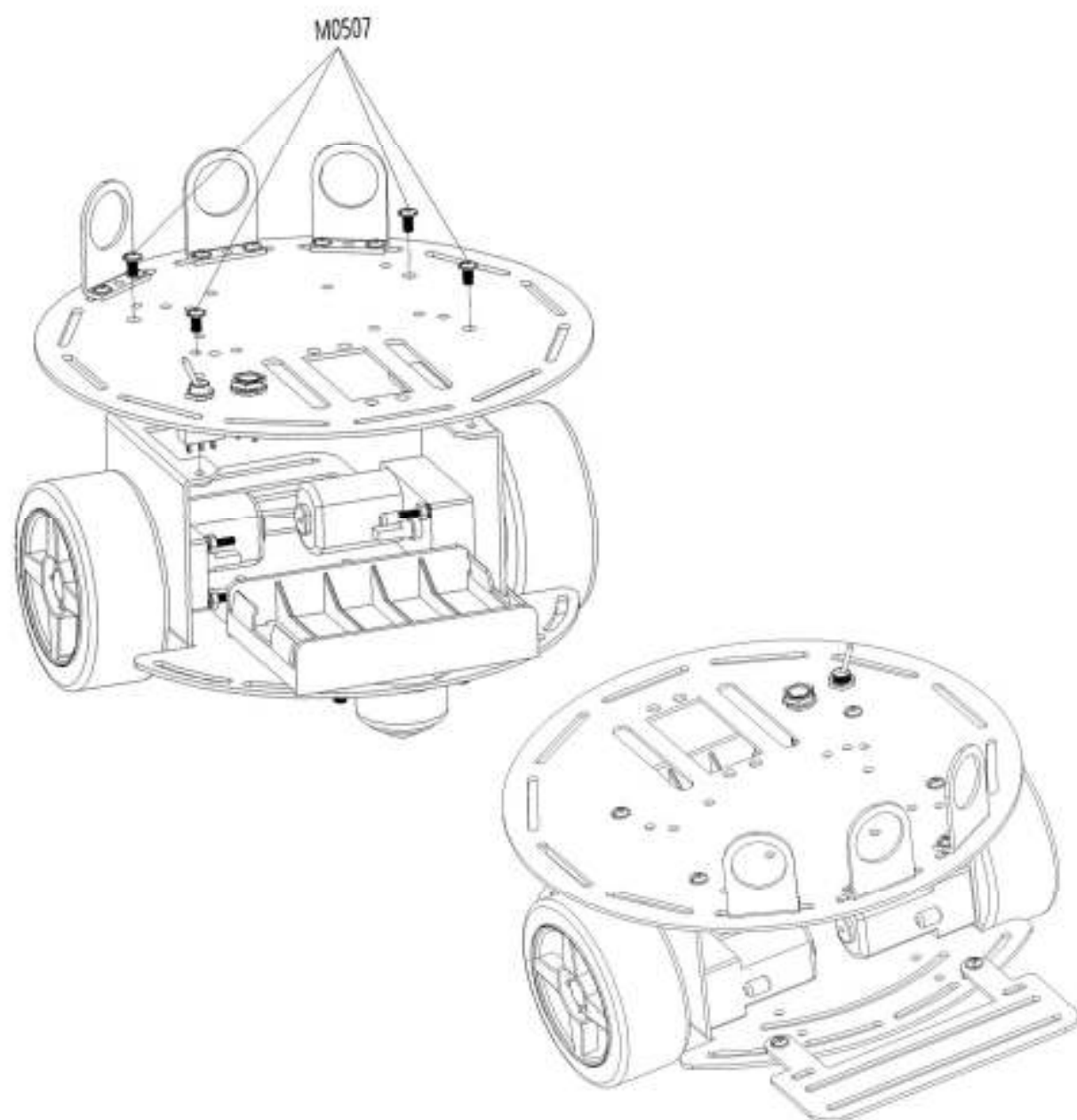

# 零部件清单 Parts List

编号 Product NO.	盒编号 BOX	袋编号 Packet	名称 Name	数量 Amount	备注 Remark
F0501		A1	车身下板 Fuselage Lower Plate	1	
F0502		A1	车身上板 Fuselage Upper Plate	1	
F0503		A1	传感器支架 Sensor Mounting Grill	1	
F0504		A2	红外传感器支架 IR Sensor Mounting Bracket	3	
F0505		A3	牛眼轮 Caster	1	
M0501		A4	M2.5x25mm 半圆头十字螺丝 Philips Truss Screw (M2.5x25mm)	4	
M0502		A4	M2.5 垫片 M2.5 Washer	4	
M0503		A4	M2.5 弹簧垫圈 M2.5 Spring Washer	4	
M0504		A4	M2.5 螺母 M2.5 Nut	4	
M0505		A5	M4X8mm 半圆头十字螺丝 Philips Truss Screw (M4X8mm)	2	
M0506		A5	M4 螺母 M4 Nut	2	
M0507		A6	M3x6mm 平圆头十字带垫螺丝 Philips Flange Screw (M3x6mm)	19	
M0508		A6	M3 螺母 M3 Nut	19	
M0509		A7	M3x5mm 沉头十字螺丝 Philips Countersunk Screw (M3x5mm)	2	
M0510		A8	M6 螺母 M6 Nut	2	
M0511		A8	M6 专用垫片 M6 Special Washer	1	
M0512		A8	电源开关 Power Switch	1	
M0513		A9	M8 螺母 M8 Nut	1	
M0514		A9	M8 弹簧垫圈 M8 Spring Washer	1	
M0515		A9	电源插口 Power Jack	1	
M0516		A10	M3x10mm 铜支柱 Copper Pillar (M3x10mm)	4	
P0501		A11	轮子 Wheel	2	
P0502		A12	电机 Motor	2	
P0503		A13	电池盒 Battery Holder	1	

设计与监制	北京龙凡汇众机器人科技有限公司
Design & Executive	Beijing LongFanHuiZhong Robotics Technology CO.,LTD
服务支持	
Service	service@dfrobot.com
网站	
Website	www.dfrobot.com

本说明书最终解释权归DFRobot所有

DFRobot has the final authority of interpretation on this manual.