

REVISIONS					
REV	ECO	DESCRIPTION	DATE	BY	APPR
B1	-	RELEASED DRAWING	JAN-18-2014	ARROW	TOMMY

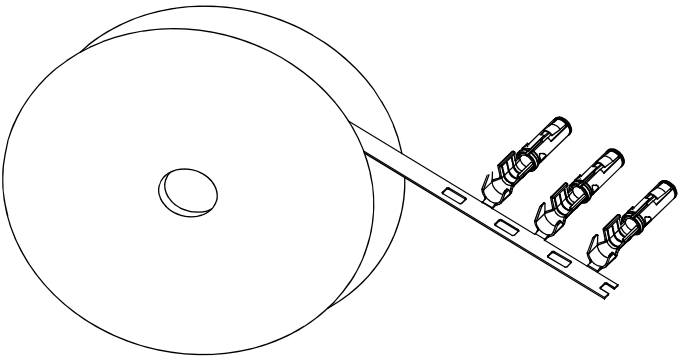

CONTACT ORIENTATION ON ROLL

NOTES : (UNLESS OTHERWISE SPECIFIED)

- 1. MATERIAL :**
 - 1.1. CONTACT BODY : COPPER ALLOY.**
 - 1.2. OUTER SPRING : STAINLESS STEEL.**
- 2. SPECIFICATIONS :**
 - 2.1 CURRENT RATING : 23A MAX.**
 - 2.2 TERMINATION TYPE : CRIMPING.**
 - 2.3 WIRE RANGE : 14~12AWG.**
 - 2.4 WIRE INSULATION DIA(MAX) : Ø4.3mm.**
- 3. ROHS COMPLIANT.**
- 4. ALL DIMENSIONS ARE FOR REFERENCE USE ONLY.**

P/N	CONTACT PLATING(MATING AREA)
SS12A1T	TIN PLATING OVER NICKEL.
SS12A1F	GOLD FLASH PLATING OVER NICKEL.
SS12A1G10	10µ" GOLD PLATING OVER NICKEL.
SS12A1G15	15µ" GOLD PLATING OVER NICKEL.
SS12A1G30	30µ" GOLD PLATING OVER NICKEL.

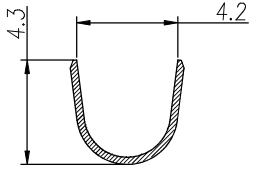

SECTION B-B

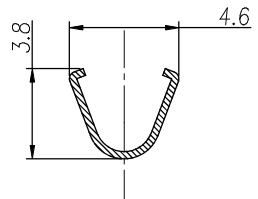

SECTION A-A

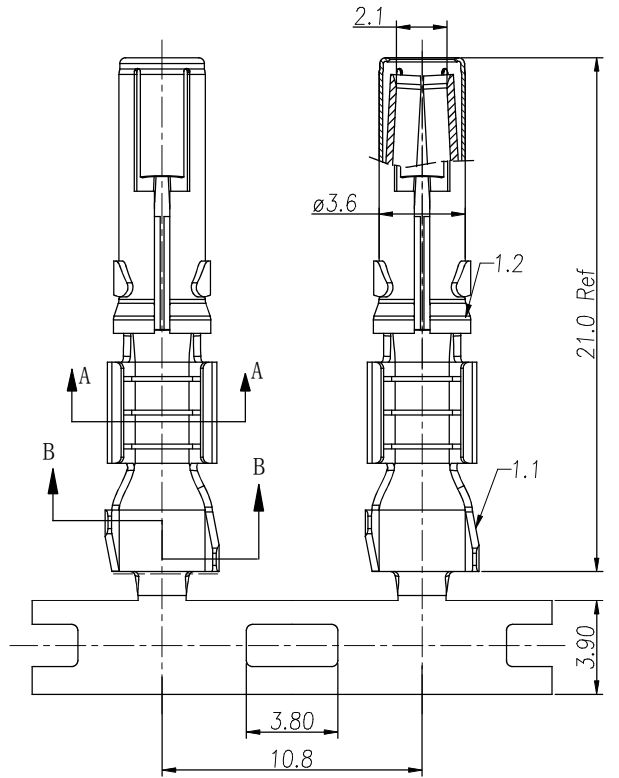

QUANTITY	PART NUMBER	DESCRIPTION	ITEM
MATERIALS LIST			
<small>UNLESS OTHERWISE SPECIFIED</small> 1) All dimensions are in metric(mm). 2) Tolerances are as follows: 1 PL DEC ±0.30 Fractions ±1/64 2 PL DEC ±0.15 3 PL DEC ±0.08 3) Note reference - Δ		<small>SIGNATURES</small> DRAWN: ARROW CHECKED: ENGINEER: APPROVAL:	<small>DATE</small> JAN-17-2014
<small>MATERIAL SPECIFICATIONS:</small>		<h1>Amphenol</h1> <p>Sine Systems - www.amphenol-sine.com 44724 Morley Drive Clinton Township, MI 48036</p>	
<small>PROCESS SPECIFICATIONS:</small>		ECO-MATE, SOCKET CONTACT, STAMPED, 14-12AWG, 2.5mm CONTACT	
<small>NEXT ASSY:</small>		<small>SIZE</small> B	<small>REVISION</small> B1
		<small>SCALE</small> NONE	<small>SHEET</small> 1 <small>OF</small> 1

TITLE: ECO-MATE, SOCKET CONTACT, STAMPED, 14-12AWG, 2.5mm
 DWG NO: SS12A1XX
 REV: B1
 SHEET: 1 OF 1