

LOC		DIST		REVISIONS			
AA	00	P	LTN	DESCRIPTION	DATE	DMN	APVD
		F1		ECR-12-003298	13FEB2012	JJ	AC
		G		ECO-15-006810	29DEC2015	LL	SH
		G1		ADD PN -9 WITH TOP 2 LEDS (DUAL COLOR)	10JAN2020	1T	SH
		G2		REVISED PER ECO-21-000623	28JUL2020	1T	SH

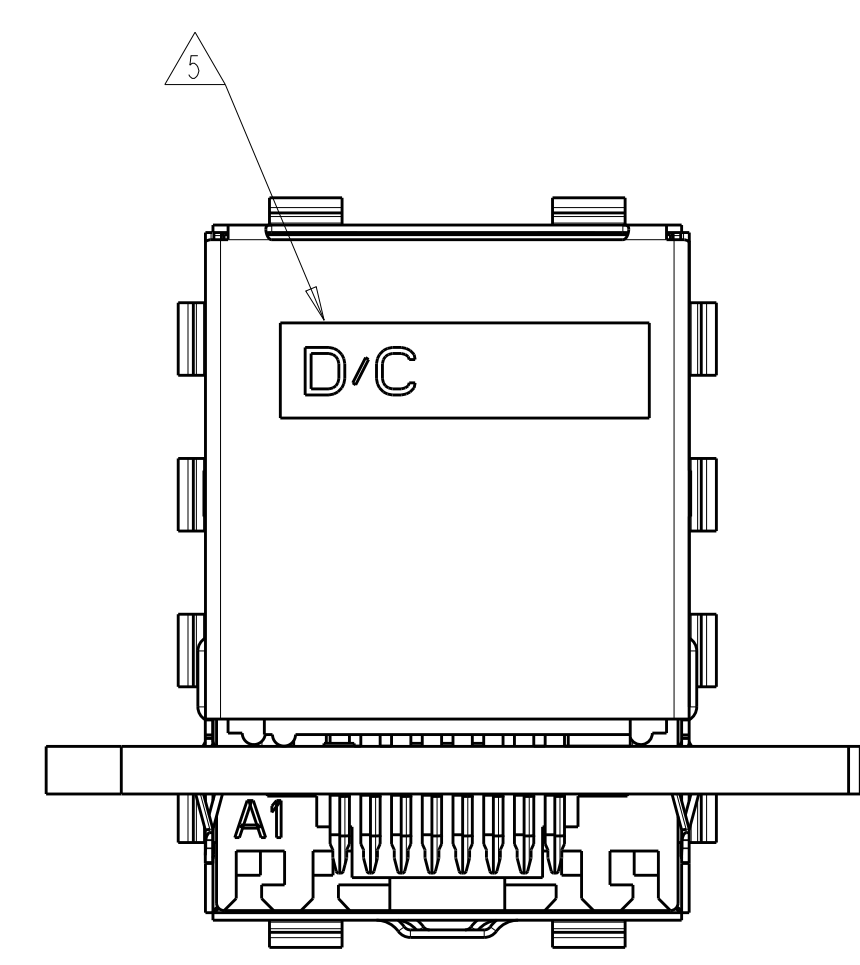

- MATERIAL:  
 HOUSING - PBT POLYESTER, BLACK, UL 94V-0  
 TERMINALS - 0.33 THICK PHOS BRONZE PLATED WITH 1.27um MINIMUM THICK HARD GOLD IN LOCALIZED AREA AND 2um MINIMUM THICK MATTE TIN IN ACTION PIN COMPLIANT PIN TERMINAL AREA OVER 1.27um MINIMUM THICK NICKEL UNDERPLATE  
 SHIELD - 0.25 THICK COPPER ALLOY PLATED WITH 1.27um MINIMUM NICKEL.  
 GROUNDING CLIP - 2.03 um MIN MATTE TIN OVER COPPER, PRE-PLATED COPPER ALLOY  
 LED - DIFFUSED EPOXY LENS 2.29 um SILVER OVER NICKEL PRE-PLATED CARBON STEEL LEADS  
 ACTION PIN - COMPLIANT PIN CONTACTS 0.3 THICK BRASS PLATED WITH 2um MINIMUM MATTE TIN OVER 1.27um MINIMUM NICKEL UNDERPLAT.
  - JACK CAVITY CONFORMS TO FCC RULES AND REGULATIONS, PART 68 SUBPART F.
- 3 DRILLED HOLE DIA = 1.020±0.025  
 COPPER THICKNESS = 0.025±0.075  
 TIN-LEAD THICKNESS = .008
- 4 DATUMS AND BASIC DIMENSIONS ESTABLISHED BY CUSTOMER
- 5 DATE CODE LOCATED ON REAR OF PART APPROXIMATELY AS SHOWN
- 6 CONTACTS ARE NOT INTENDED TO BE ALIGNED WITH EACH OTHER
- 7 OBSOLETE PARTS: OBSOLETE CIS STREAMLINING PER D.RENAUD/D.SINISI
- 8 ONLY FOR 6368168-7, -8  
 CONTACT AREA LUBRICATED WITH BELLCORE APPROVED LUBRICANT TECHNICAL REFERENCE GR-1217-CORE ISSUE 1, NOVEMBER 1995.

## 6368168-1 SHOWN SHEET 1

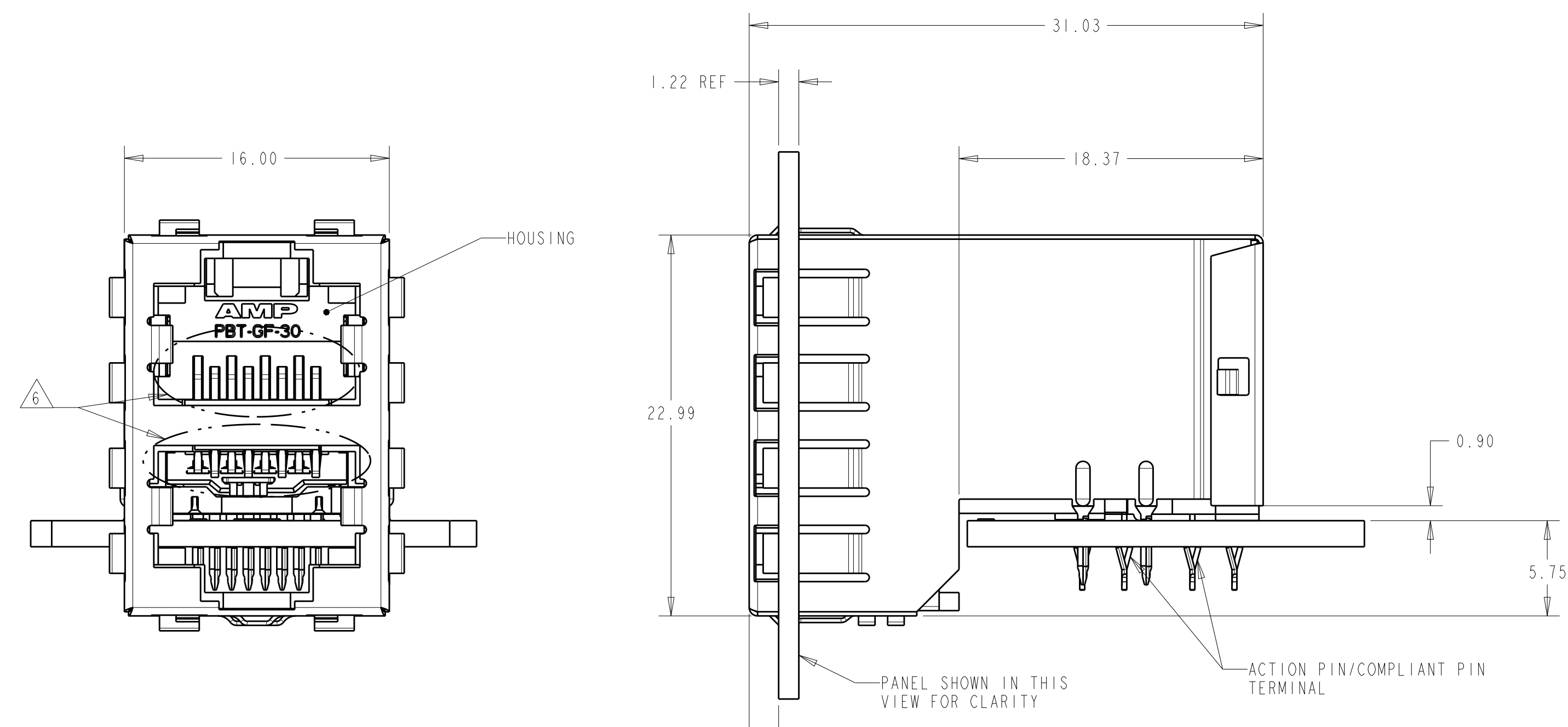
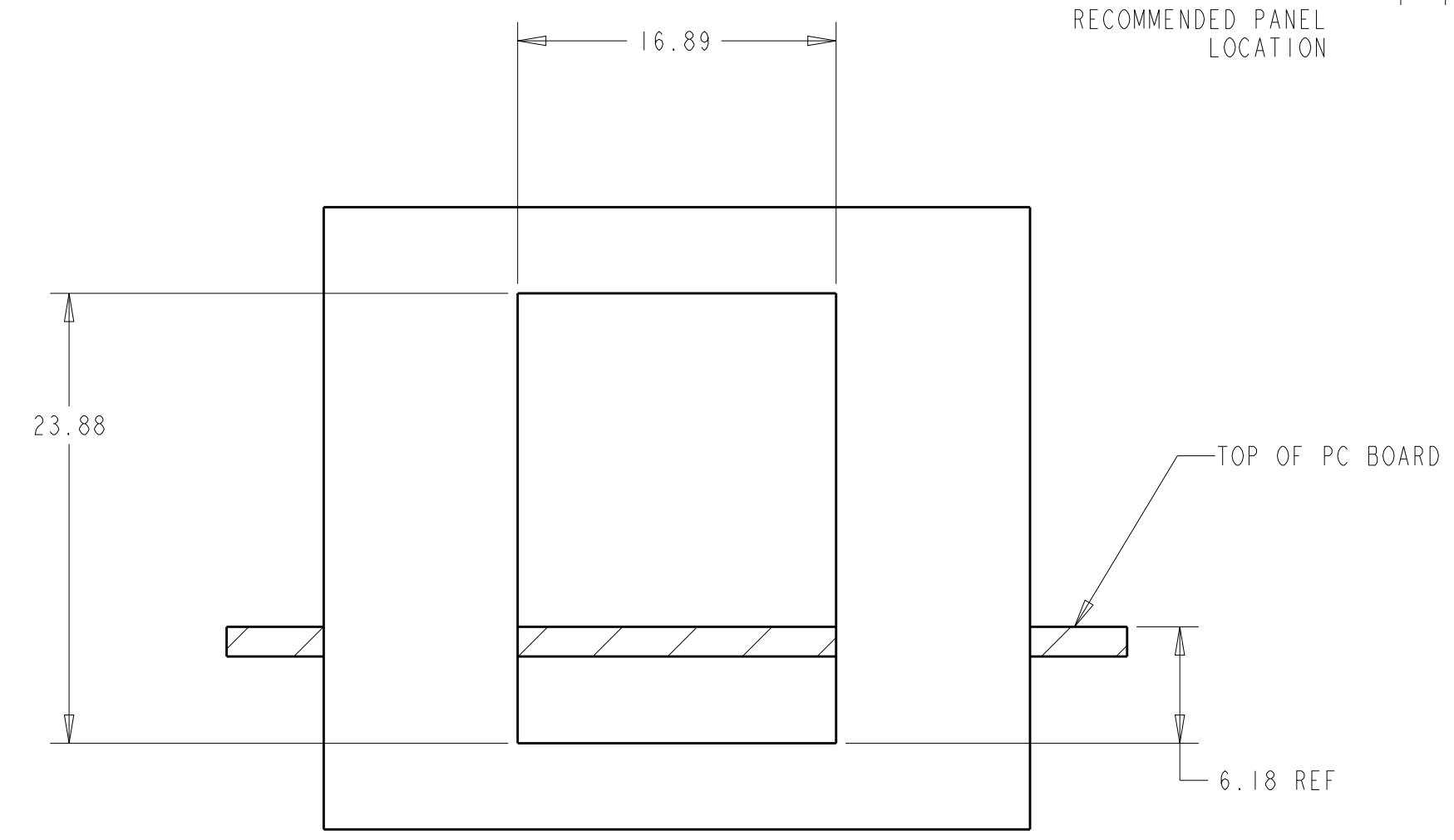

SHIELD WITH NO LED CUTOUTS AND STANDARD PANEL GROUNDS

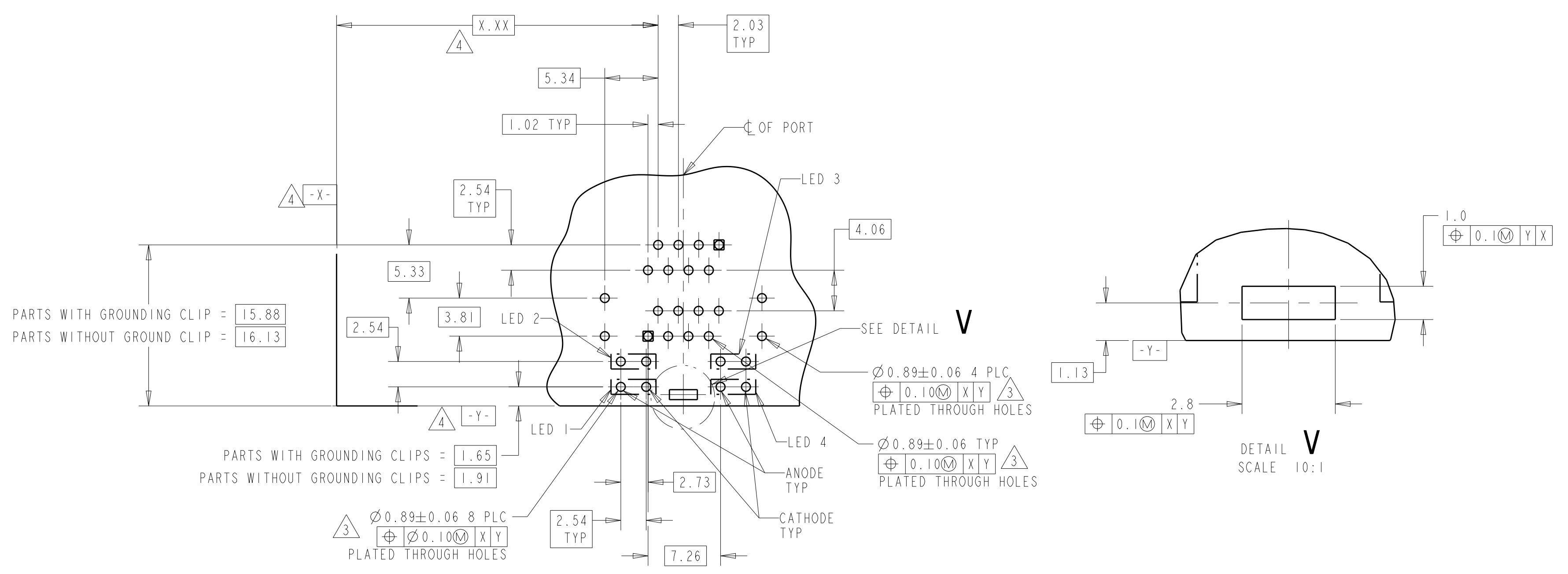
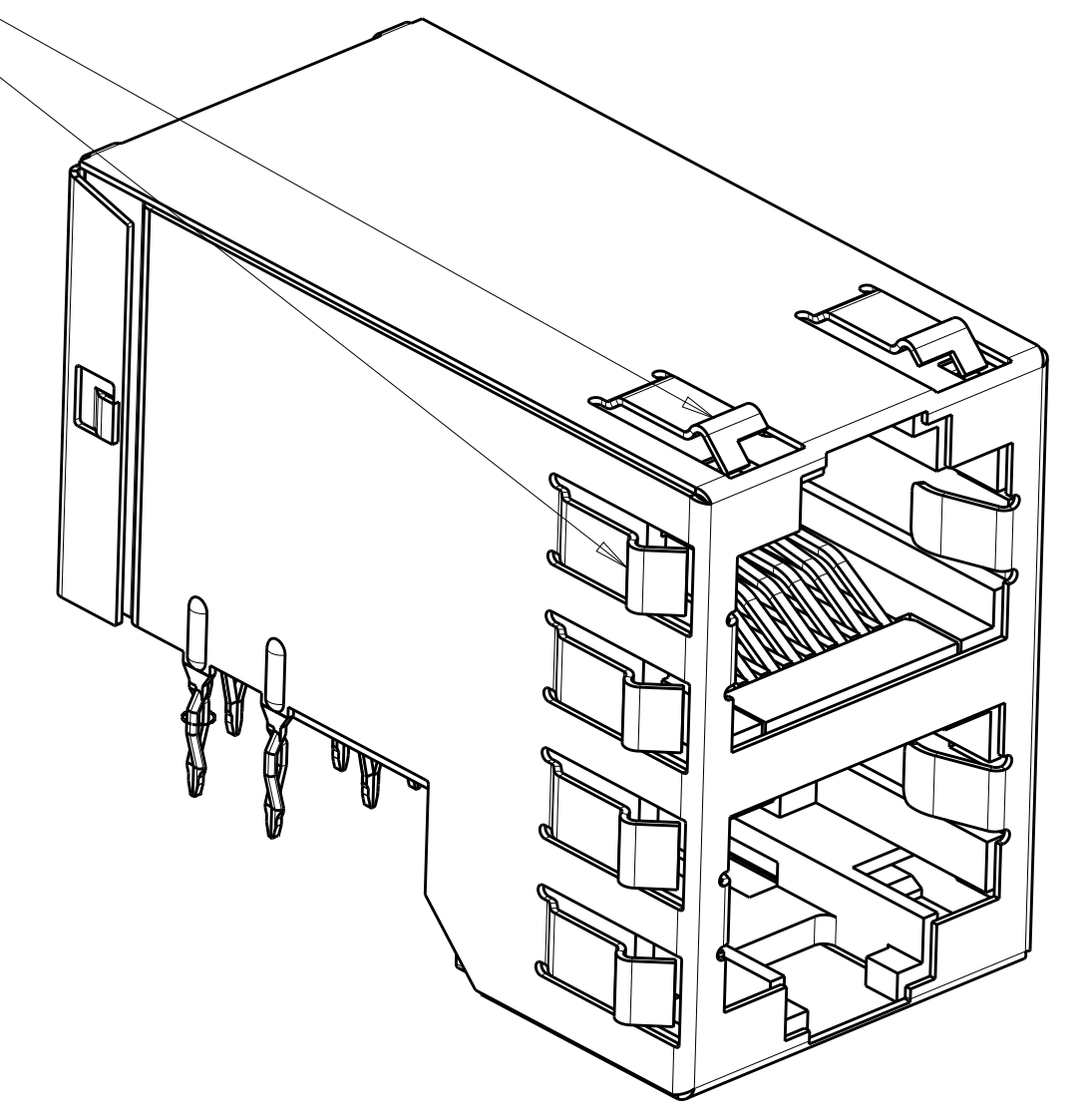

N/A	GREEN/YELLOW	GREEN/YELLOW	N/A	YES	WITH TOP 2 LED PORTS	6368168-9
N/A	N/A	N/A	N/A	NO	WITHOUT LED PORTS	6368168-8
GREEN	GREEN	GREEN	GREEN	NO	WITH LED PORTS	6368168-7
GREEN	GREEN	YELLOW	YELLOW	YES	WITH LED PORTS	6368168-6
GREEN	GREEN	GREEN	GREEN	YES	WITH LED PORTS	6368168-5
YELLOW	YELLOW	GREEN	GREEN	YES	WITH LED PORTS	6368168-4
N/A	N/A	N/A	N/A	YES	WITHOUT LED PORTS	6368168-2
N/A	N/A	N/A	N/A	NO	WITHOUT LED PORTS	6368168-1
LED #4	LED #3	LED #2	LED #1	GROUNDING CLIP	SHIELD STYLE	PART NUMBER

### PC BOARD LAYOUT (COMPONENT SIDE)

THIS DRAWING IS A CONTROLLED DOCUMENT. DWG: A.FERNANDEZ-DOCK 28 JUL 2005  
 CHG: J.WESTMAN 28 JUL 2005  
 APVD: S.FLICKINGER 28 JUL 2005

TE Connectivity

NAME: STACKED MODULAR JACK ASSEMBLY, 2X1, 8 POSITION, SHIELDED PANEL GROUND, OFFSET, CAT 5

PRODUCT SPEC: 108-1854  
 APPLICATION SPEC: 114-2160  
 WEIGHT: -  
 SCALE: 3:1 SHEET 1 OF 2 REV: G2

SIZE: A1 CAGE CODE: 00779 DRAWING NO: 6368168

LOC		DIST		REVISIONS			
AA	00	P	LYR	DESCRIPTION	DATE	DWN	APVD
		-		SEE SHEET 1			

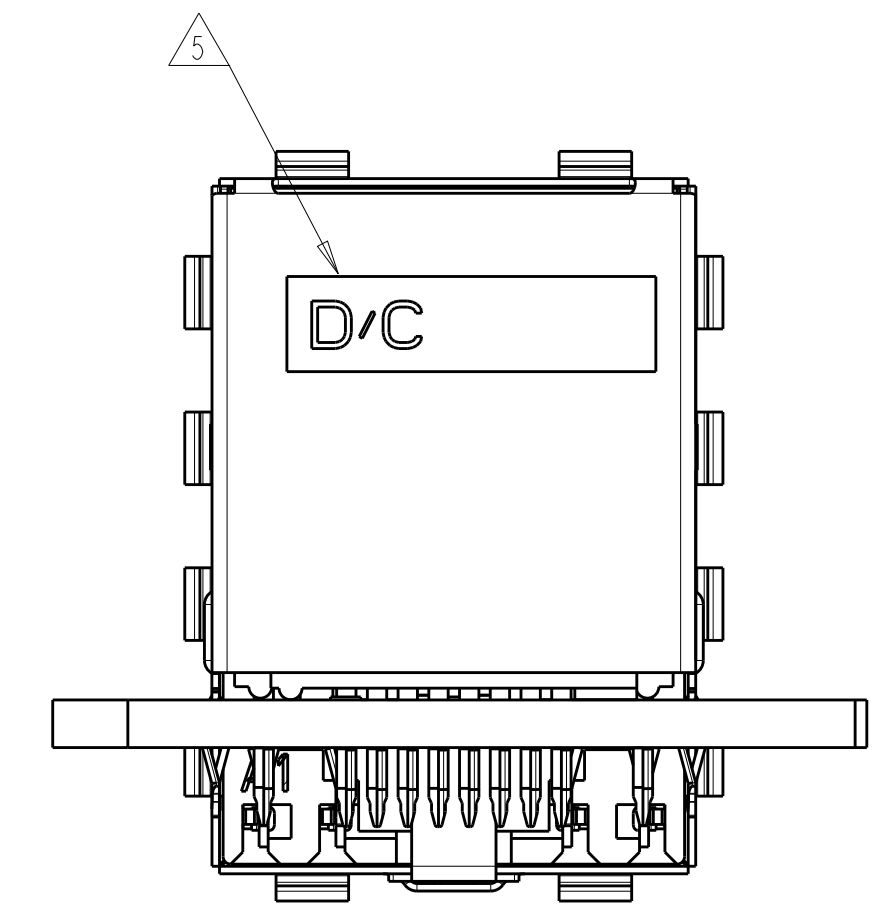
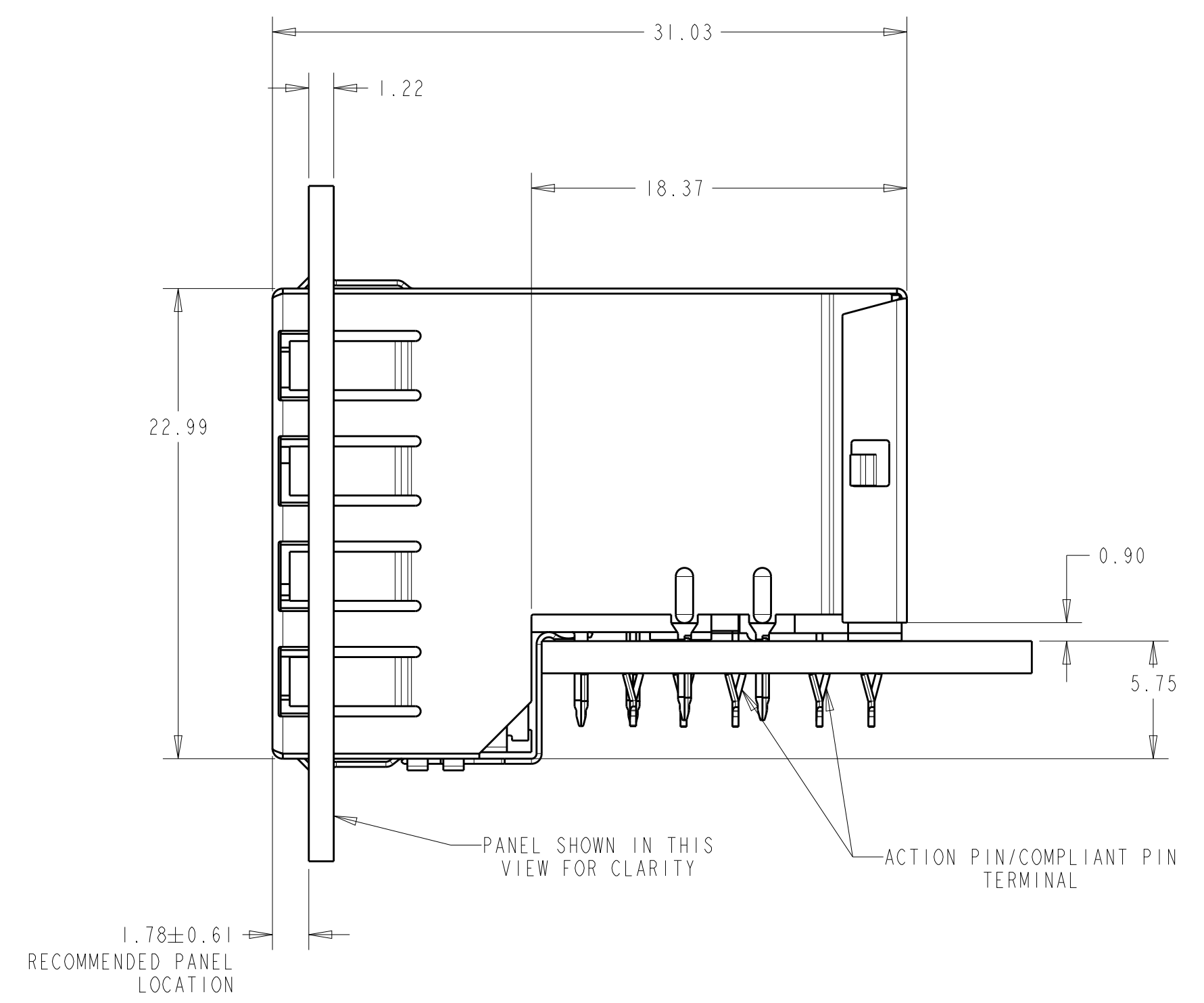
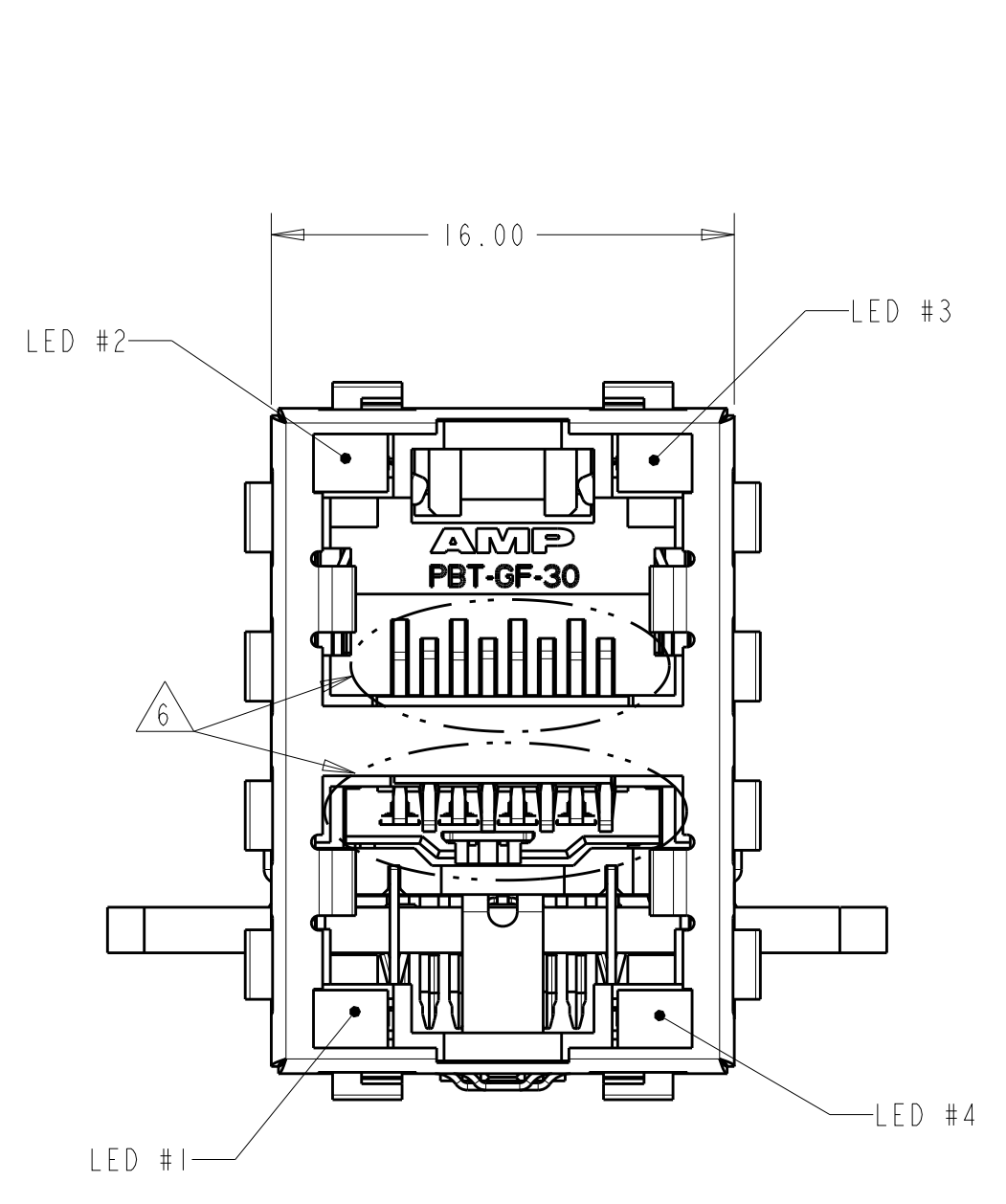

**6368168-6 AS SHOWN**

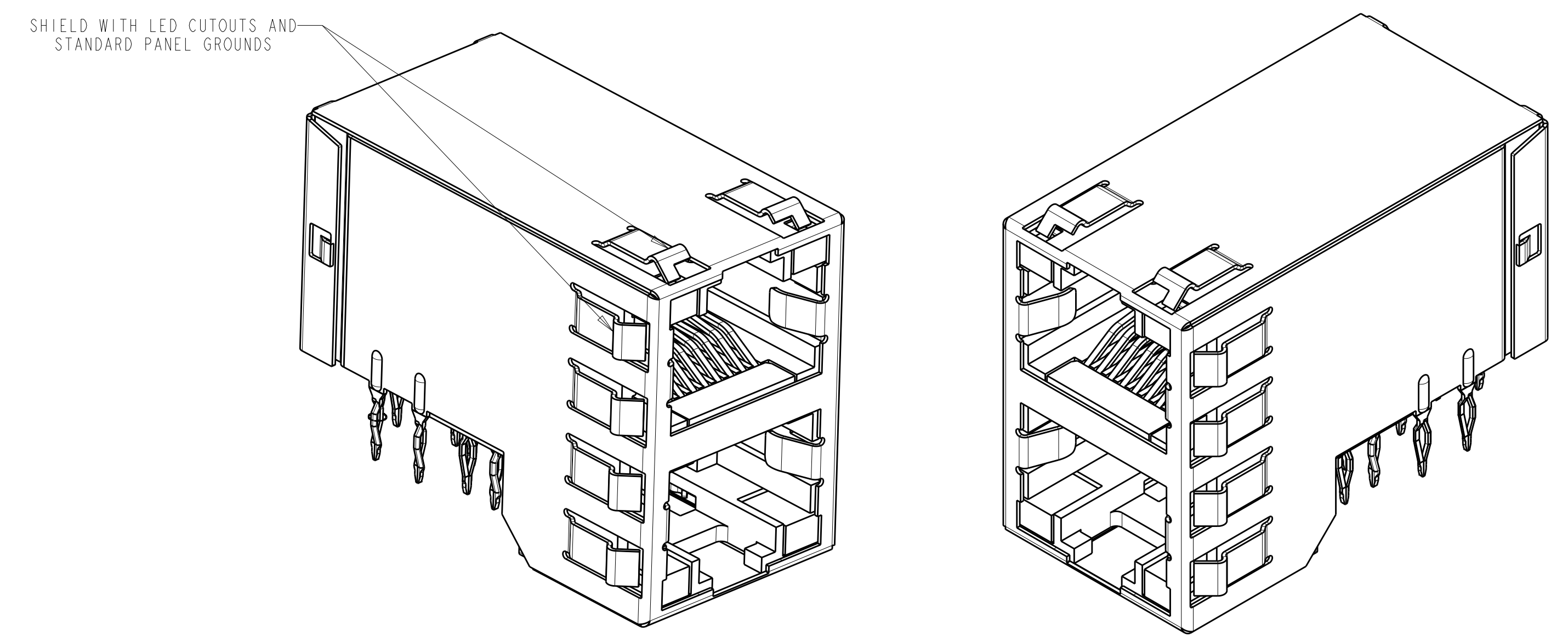

**6368168-6 3D VIEW**

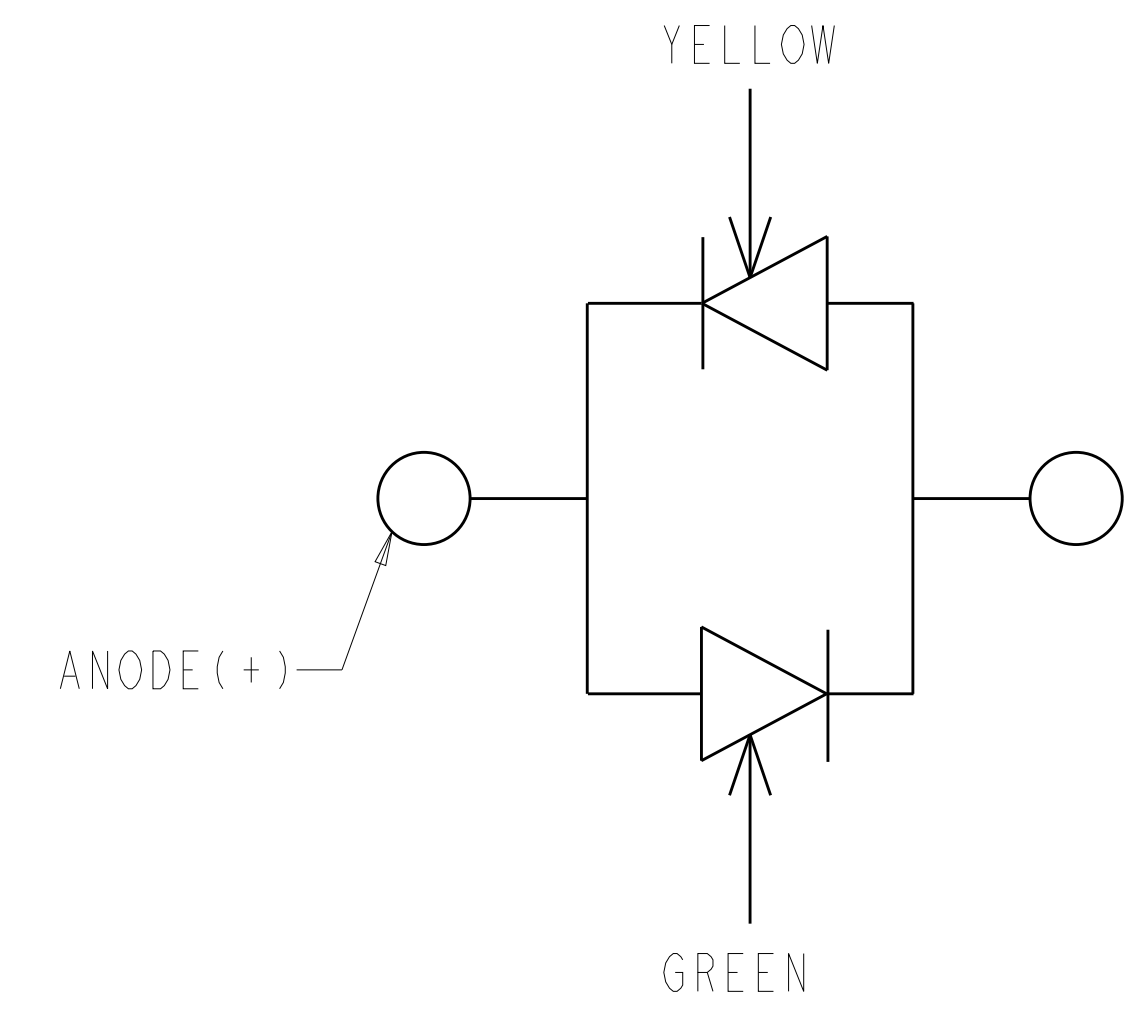
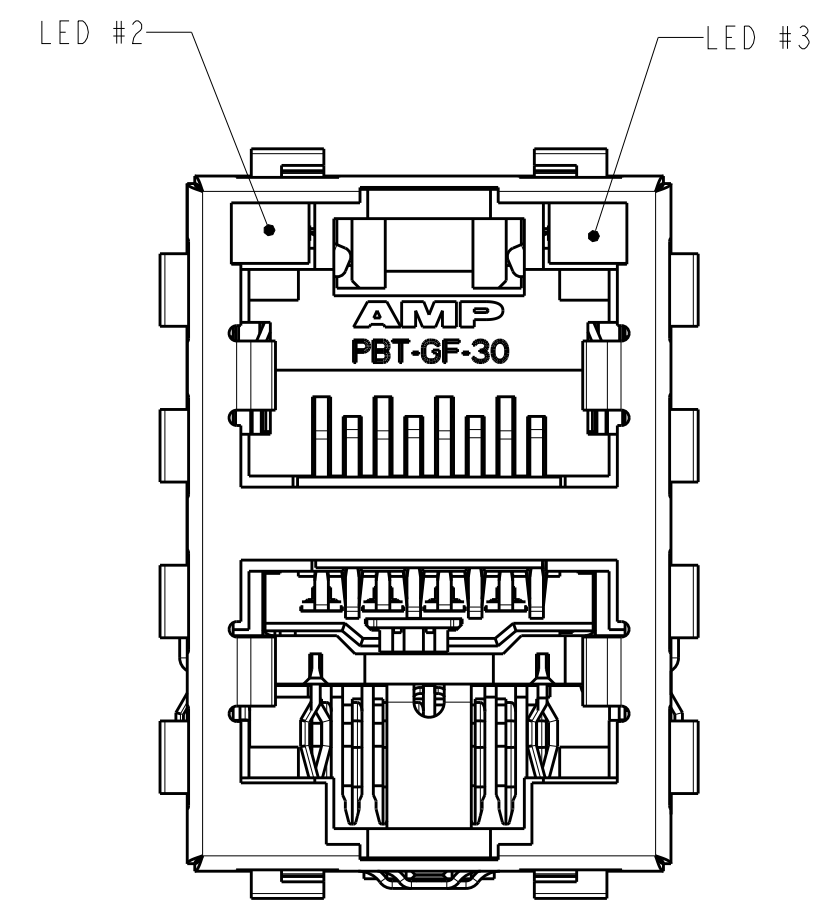

6368168-9 AS SHOWN  
 UNMARKED DIMENSIONS SAME  
 AS 6368168-1

6368168-9  
 LED CURRENT DIAGRAM

THIS DRAWING IS A CONTROLLED DOCUMENT.		DWN A. FERNANDEZ 28 JUL 2005	TE Connectivity	
DIMENSIONS: mm		CHK J. WESTMAN 28 JUL 2005		
TOLERANCES UNLESS OTHERWISE SPECIFIED: 0 PLC ± 2 PLC ±0.1 3 PLC ±0.13 4 PLC ± ANGLES ±		APVD S. FLICKINGER 28 JUL 2005		
MATERIAL SEE NOTE 1		FINISH SEE NOTE 1	PRODUCT SPEC 108-1854	SIZE A1
		WEIGHT	APPLICATION SPEC 114-2160	CAGE CODE 00779
			REVISIONS C=6368168	SCALE 3:1
			CUSTOMER DRAWING	SHEET 2 OF 2
				REV G2