

**ARM® Cortex®-M  
32-bit Microcontroller****NuMicro® Family  
Nano100 Series  
Datasheet**

*The information described in this document is the exclusive intellectual property of Nuvoton Technology Corporation and shall not be reproduced without permission from Nuvoton.*

*Nuvoton is providing this document only for reference purposes of NuMicro microcontroller based system design. Nuvoton assumes no responsibility for errors or omissions.*

*All data and specifications are subject to change without notice.*

For additional information or questions, please contact: Nuvoton Technology Corporation.

[www.nuvoton.com](http://www.nuvoton.com)

**Table of Contents**

*LIST OF FIGURES*..... 6

*LIST OF TABLES*..... 7

1 GENERAL DESCRIPTION ..... 8

2 FEATURES ..... 10

    2.1 Nano100 Features – Base Line ..... 10

    2.2 Nano110 Features – LCD Line ..... 16

    2.3 Nano120 Features – USB Connectivity Line..... 22

    2.4 Nano130 Features – Advanced Line..... 28

3 PARTS INFORMATION LIST AND PIN CONFIGURATION ..... 34

    3.1 NuMicro® Nano100 Series Selection Code ..... 34

    3.2 NuMicro® Nano100 Products Selection Guide ..... 35

        3.2.1 NuMicro® Nano100 Base Line Selection Guide..... 35

        3.2.2 NuMicro® Nano110 LCD Line Selection Guide..... 35

        3.2.3 NuMicro® Nano120 USB Connectivity Line Selection Guide ..... 35

        3.2.4 NuMicro® Nano130 Advanced Line Selection Guide ..... 36

    3.3 Pin Configuration ..... 37

        3.3.1 NuMicro® Nano100 Pin Diagrams ..... 37

        3.3.2 NuMicro® Nano110 Pin Diagrams ..... 40

        3.3.3 NuMicro® Nano120 Pin Diagrams ..... 42

        3.3.4 NuMicro® Nano130 Pin Diagrams ..... 45

    3.4 Pin Description ..... 47

        3.4.1 NuMicro® Nano100 Pin Description ..... 47

        3.4.2 NuMicro® Nano110 Pin Description ..... 58

        3.4.3 NuMicro® Nano120 Pin Description ..... 72

        3.4.4 NuMicro® Nano130 Pin Description ..... 83

4 BLOCK DIAGRAM ..... 97

    4.1 Nano100 Block Diagram ..... 97

    4.2 Nano110 Block Diagram ..... 98

    4.3 Nano120 Block Diagram ..... 99

    4.4 Nano130 Block Diagram ..... 100

5 FUNCTIONAL DESCRIPTION..... 101

    5.1 Memory Organization ..... 101

        5.1.1 Overview ..... 101

        5.1.2 Memory Map ..... 101

    5.2 Nested Vectored Interrupt Controller (NVIC) ..... 103

        5.2.1 Overview ..... 103

        5.2.2 Features ..... 103

    5.3 System Manager ..... 104

        5.3.1 Overview ..... 104

        5.3.2 Features ..... 104

    5.4 Clock Controller ..... 105

        5.4.1 Overview ..... 105

5.4.2	Features .....	105
5.5	Analog to Digital Converter (ADC) .....	106
5.5.1	Overview .....	106
5.5.2	Features .....	106
5.6	Digital to Analog Converter (DAC) .....	107
5.6.1	Overview .....	107
5.6.2	Features .....	107
5.7	DMA Controller .....	108
5.7.1	Overview .....	108
5.7.2	Features .....	108
5.8	External Bus Interface .....	110
5.8.1	Overview .....	110
5.8.2	Features .....	110
5.9	FLASH Memory Controller (FMC) .....	111
5.9.1	Overview .....	111
5.9.2	Features .....	111
5.10	General Purpose I/O Controller .....	112
5.10.1	Overview .....	112
5.10.2	Features .....	112
5.11	I <sup>2</sup> C .....	113
5.11.1	Overview .....	113
5.11.2	Features .....	114
5.12	I <sup>2</sup> S .....	115
5.12.1	Overview .....	115
5.12.2	Features .....	115
5.13	LCD Display Driver .....	116
5.13.1	Overview .....	116
5.13.2	Features .....	116
5.14	Pulse Width Modulation (PWM) .....	117
5.14.1	Overview .....	117
5.14.2	Features .....	118
5.15	RTC .....	119
5.15.1	Overview .....	119
5.15.2	Features .....	119
5.16	Smart Card Host Interface (SC) .....	119
5.16.1	Overview .....	119
5.16.2	Features .....	119
5.17	SPI .....	121
5.17.1	Overview .....	121
5.17.2	Features .....	121
5.18	Timer Controller .....	122
5.18.1	Overview .....	122
5.18.2	Features .....	122
5.19	UART Controller .....	123

- 5.19.1 Overview ..... 123
- 5.19.2 The LIN mode is selected by setting the LIN\_EN bit in UART\_FUN\_SEL register. In LIN mode, one start bit and 8-bit data format with 1-bit stop bit are required in accordance with the LIN standard. Features..... 124
- 5.20 USB ..... 126
  - 5.20.1 Overview ..... 126
  - 5.20.2 Features ..... 126
- 5.21 Watchdog Timer Controller ..... 127
  - 5.21.1 Overview ..... 127
  - 5.21.2 Features ..... 127
- 5.22 Window Watchdog Timer Controller ..... 128
  - 5.22.1 Overview ..... 128
  - 5.22.2 Features ..... 128
- 6 ARM® CORTEX™-M0 CORE ..... 129
  - 6.1 Overview..... 129
  - 6.2 Features ..... 129
- 7 APPLICATION CIRCUIT ..... 131
  - 7.1 LCD Charge Pump ..... 131
    - 7.1.1 C-type 1/3 Bias ..... 131
    - 7.1.2 C-type 1/2 Bias ..... 131
    - 7.1.3 Internal R-type ..... 131
    - 7.1.4 External R-type..... 132
  - 7.2 ADC Application Circuit ..... 133
    - 7.2.1 Voltage Reference Source ..... 133
  - 7.3 DAC Application Circuit ..... 135
    - 7.3.1 Voltage Reference Source ..... 135
  - 7.4 Whole Chip Application Circuit ..... 137
- 8 POWER COMSUMPTION ..... 138
- 9 ELECTRICAL CHARACTERISTIC ..... 139
  - 9.1 Absolute Maximum Ratings..... 139
  - 9.2 Nano100/Nano110/Nano120/Nano130 DC Electrical Characteristics ..... 139
  - 9.3 AC Electrical Characteristics ..... 145
    - 9.3.1 External Input Clock ..... 145
    - 9.3.2 External 4~24 MHz XTAL Oscillator ..... 145
    - 9.3.3 External 32.768 kHz Crystal ..... 146
    - 9.3.4 Internal 12 MHz Oscillator ..... 146
    - 9.3.5 Internal 10 kHz Oscillator ..... 146
  - 9.4 Analog Characteristics ..... 146
    - 9.4.1 12-bit ADC ..... 146
    - 9.4.2 Brown-out Detector..... 147
    - 9.4.3 Power-on Reset..... 148
    - 9.4.4 Temperature Sensor..... 148
    - 9.4.5 12-bit DAC ..... 148
    - 9.4.6 LCD ..... 149
    - 9.4.7 Internal Voltage Reference ..... 149

9.4.8 USB PHY Specifications..... 149

9.5 Flash DC Electrical Characteristics ..... 151

10 PACKAGE DIMENSIONS ..... 152

10.1 LQFP128 (14x14x1.4 mm footprint 2.0 mm)..... 152

10.2 LQFP64 (10x10x1.4 mm footprint 2.0 mm)..... 153

10.3 LQFP64 (7x7x1.4 mm footprint 2.0 mm)..... 154

10.4 LQFP48 (7x7x1.4 mm footprint 2.0 mm)..... 156

10.5 QFN48 (7x7x0.85 mm)..... 157

11 REVISION HISTORY ..... 158

*LIST OF FIGURES*

Figure 3-1 NuMicro® Nano100 Series Selection Code..... 34

Figure 3-2 NuMicro® Nano100 LQFP 128-pin Diagram ..... 37

Figure 3-3 NuMicro® Nano100 LQFP 64-pin Diagram ..... 38

Figure 3-4 NuMicro® Nano100 LQFP 48-pin Diagram..... 39

Figure 3-5 NuMicro® Nano110 LQFP 128-pin Diagram..... 40

Figure 3-6 NuMicro® Nano110 LQFP 64-pin Diagram..... 41

Figure 3-7 NuMicro® Nano120 LQFP 128-pin Diagram..... 42

Figure 3-8 NuMicro® Nano120 LQFP 64-pin Diagram..... 43

Figure 3-9 NuMicro® Nano120 LQFP 48-pin Diagram..... 44

Figure 3-10 NuMicro® Nano130 LQFP 128-pin Diagram..... 45

Figure 3-11 NuMicro® Nano130 LQFP 64-pin Diagram..... 46

Figure 4-1 NuMicro® Nano100 Block Diagram ..... 97

Figure 4-2 NuMicro® Nano110 Block Diagram ..... 98

Figure 4-3 NuMicro® Nano120 Block Diagram ..... 99

Figure 4-4 NuMicro® Nano130 Block Diagram ..... 100

Figure 6-1 M0 Functional Block..... 129

Figure 9-1 Typical Crystal Application Circuit..... 145

*LIST OF TABLES*

Table 1-1 Connectivity Support Table ..... 9

Table 3-1 Nano100 Base Line Selection Table ..... 35

Table 3-2 Nano110 LCD Line Selection Table ..... 35

Table 3-3 Nano120 USB Connectivity Line Selection Table ..... 35

Table 3-4 Nano130 Advanced Line Selection Table ..... 36

Table 5-12 UART Baud Rate Equation ..... 123

Table 5-13 UART Baud Rate Setting ..... 124

## 1 GENERAL DESCRIPTION

The Nano100 series ultra-low power 32-bit microcontroller is embedded with ARM® Cortex™-M0 core operated at a wide voltage range from 1.8V to 3.6V and runs up to 42 MHz frequency with 32K/64K/128K bytes embedded Flash and 8K/16K-byte embedded SRAM. Integrating LCD 4x40 or 6x38 (COM/Segment), USB 2.0 full-speed function, RTC, 12-bit SAR ADC, 12-bit DAC and provides high performance connectivity peripheral interfaces such as UART, SPI, I<sup>2</sup>C, I<sup>2</sup>S, GPIOs, EBI (External Bus Interface) for external memory-mapped device access and ISO-7816-3 for Smart card, the Nano100 series supports Brown-out Detector, Power-down mode with RAM retention and fast wake-up via many peripheral interfaces.

The Nano100 series provides low power voltage, low power consumption, low standby current, high integration peripherals, high-efficiency operation, fast wake-up function and the lowest cost 32-bit microcontrollers. The Nano100 series is suitable for a wide range of battery device applications such as:

- Portable Data Collector
- Portable Medical Monitor
- Portable RFID Reader
- Portable Barcode Scanner
- Security Alarm System
- System Supervisors
- Power Metering
- USB Accessories
- Smart Card Reader
- Wireless Game Control Device
- IPTV Remote Smart Keyboard
- Wireless Sensors Node Device (WSN)
- Wireless RF4CE Remote Control
- Wireless Audio
- Wireless Automatic Meter Reader (AMR)
- Electronic Toll Collection (ETC)

The Nano100 Base line, an ultra-low power 32-bit microcontroller with the embedded ARM® Cortex™-M0 core, operates at wide voltage range from 1.8V to 3.6V and runs up to 42 MHz frequency with 32K/64K/128K bytes embedded flash and 8K/16K bytes embedded SRAM. It integrates RTC, 12- channels 12-bit SAR ADC, 2-channels 12-bit DAC and provides high performance connectivity peripheral interfaces such as 2xUART, 3xSPI, 2xI<sup>2</sup>C, I<sup>2</sup>S, GPIOs, EBI (External Bus Interface) for external memory-mapped device access and 3xISO-7816-3 for Smart card. The Nano100 Base line supports Brown-out Detector, Power-down mode with RAM retention and fast wake-up via many peripheral interfaces.

The Nano110 LCD line, an ultra-low power 32-bit microcontroller with the embedded ARM® Cortex™-M0 core, operates at wide voltage range from 1.8V to 3.6V and runs up to 42 MHz frequency with 32K/64K/128K bytes embedded flash and 8K/16K bytes embedded SRAM. It integrates LCD 4x40 or 6x38 (COM/Segment). RTC, 12-channels 12-bit SAR ADC, 2-channels 12-bit DAC and provides high performance connectivity peripheral interfaces such as 2xUART, 2xSPI, 2xI<sup>2</sup>C, I<sup>2</sup>S, GPIOs, EBI (External Bus Interface) for external memory-mapped device access and 3xISO-7816-3 for Smart card. The Nano110 LCD line supports Brown-out Detector, Power-down mode with RAM retention and fast wake-up via many peripheral interfaces.



The Nano120 USB Connectivity line, an ultra-low power 32-bit microcontroller with the embedded ARM® Cortex™-M0 core, operates at wide voltage range from 1.8V to 3.6V and runs up to 42 MHz frequency with 32K/64K/128K bytes embedded flash and 8K/16K bytes embedded SRAM. It integrates USB 2.0 full-speed device function, RTC, 12-channels 12-bit SAR ADC, 2-channels 12-bit DAC and provides high performance connectivity peripheral interfaces such as 2xUART, 3xSPI, 2xI2C, I2S, GPIOs, EBI (External Bus Interface) for external memory-mapped device access and 3xISO-7816-3 for Smart card. The Nano120 USB Connectivity line supports Brown-out Detector, Power-down mode with RAM retention and fast wake-up via many peripheral interfaces.

The Nano130 Advanced line, an ultra-low power 32-bit microcontroller with the embedded ARM® Cortex™-M0 core, operates at wide voltage range from 1.8V to 3.6V and runs up to 42 MHz frequency with 32K/64K/128K bytes embedded flash and 8K/16K bytes embedded SRAM. It integrated LCD 4x40 or 6x38 (COM/Segment), USB 2.0 full-speed device function, RTC, 8-channels 12-bit SAR ADC, 2-channels 12-bit DAC and provides high performance connectivity peripheral interfaces such as 2xUART, 2xSPI, 2xI<sup>2</sup>C, I<sup>2</sup>S, GPIOs, EBI (External Bus Interface) for external memory-mapped device access and 3xISO-7816-3 for Smart card. The Nano130 Advanced line supports Brown-out Detector, Power-down mode with RAM retention and fast wake-up via many peripheral interfaces.

Product Line	UART	SPI	I <sup>2</sup> C	I <sup>2</sup> S	USB	LCD	ADC	DAC	RTC	EBI	SC	Timer
Nano100	●	●	●	●			●	●	●	●	●	●
Nano110	●	●	●	●		●	●	●	●	●	●	●
Nano120	●	●	●	●	●		●	●	●	●	●	●
Nano130	●	●	●	●	●	●	●	●	●	●	●	●

Table 1-1 Connectivity Support Table

## 2 FEATURES

The equipped features are dependent on the product line and their sub products.

### 2.1 Nano100 Features – Base Line

- Core
  - ◆ ARM® Cortex™-M0 core running up to 42 MHz
  - ◆ One 24-bit system timer
  - ◆ Supports Low Power Sleep mode
  - ◆ Single-cycle 32-bit hardware multiplier
  - ◆ NVIC for the 32 interrupt inputs, each with 4-levels of priority
  - ◆ Serial Wire Debug supports with 2 watchpoints/4 breakpoints
- Brown-out
  - ◆ Built-in 2.5V/2.0V/1.7V BOD for wide operating voltage range operation
- Flash EPROM Memory
  - ◆ Runs up to 42 MHz with zero wait state for discontinuous address read access
  - ◆ 64K/32K/123K bytes application program memory (APROM)
  - ◆ 4 KB in system programming (ISP) loader program memory (LDRM)
  - ◆ Programmable data flash start address and memory size with 512 bytes page erase unit
  - ◆ In System Program (ISP)/In Application Program (IAP) to update on-chip Flash EPROM
- SRAM Memory
  - ◆ 16K/8K bytes embedded SRAM
  - ◆ Supports DMA mode
- DMA: Supports 8 channels: one VDMA channel, 6 PDMA channels and one CRC channel
  - ◆ VDMA
    - Memory-to-memory transfer
    - Supports block transfer with stride
    - Supports word/half-word/byte boundary address
    - Supports address direction: increment and decrement
  - ◆ PDMA
    - Peripheral-to-memory, memory-to-peripheral, and memory-to-memory transfer
    - Supports word boundary address
    - Supports word alignment transfer length in memory-to-memory mode
    - Supports word/half-word/byte alignment transfer length in peripheral-to-memory and memory-to-peripheral mode
    - Supports word/half-word/byte transfer data width from/to peripheral

- Supports address direction: increment, fixed, and wrap around
  - ◆ CRC
    - Supports four common polynomials CRC-CCITT, CRC-8, CRC-16, and CRC-32
      - ◆ CRC-CCITT:  $X^{16} + X^{12} + X^5 + 1$
      - ◆ CRC-8:  $X^8 + X^2 + X + 1$
      - ◆ CRC-16:  $X^{16} + X^{15} + X^2 + 1$
      - ◆ CRC-32:  $X^{32} + X^{26} + X^{23} + X^{22} + X^{16} + X^{12} + X^{11} + X^{10} + X^8 + X^7 + X^5 + X^4 + X^2 + X + 1$
- Clock Control
  - ◆ Flexible selection for different applications
  - ◆ Built-in 12 MHz OSC, can be trimmed to 0.25% deviation within all temperature range when turning on auto-trim function (system must have external 32.768 kHz crystal input) otherwise 12 MHz OSC has 2 % deviation within all temperature range.
  - ◆ Low power 10 kHz OSC for watchdog and low power system operation
  - ◆ Supports one PLL, up to 120 MHz, for high performance system operation and USB application (48 MHz).
  - ◆ External 4~24 MHz crystal input for precise timing operation
  - ◆ External 32.768 kHz crystal input for RTC function and low power system operation
- GPIO
  - ◆ Three I/O modes:
    - Push-Pull output
    - Open-Drain output
    - Input only with high impedance
  - ◆ All inputs with Schmitt trigger
  - ◆ I/O pin configured as interrupt source with edge/level setting
  - ◆ Supports High Driver and High Sink I/O mode
  - ◆ Supports input 5V tolerance, except PA.0 ~ PA.7, PD.0 ~ PD.1 and PC.6 ~ PC.7
- Timer
  - ◆ Supports 4 sets of 32-bit timers, each with 24-bit up-counting timer and one 8-bit pre-scale counter
  - ◆ Independent Clock Source for each timer
  - ◆ Provides one-shot, periodic, output toggle and continuous operation modes
  - ◆ Internal trigger event to ADC, DAC and PDMA
  - ◆ Supports PDMA mode
  - ◆ Wake system up from Power-down mode
- Watchdog Timer
  - ◆ Clock Source from LIRC (Internal 10 kHz Low Speed Oscillator Clock)

- ◆ Selectable time-out period from 1.6 ms ~ 26 sec (depending on clock source)
- ◆ Interrupt or reset selectable when watchdog time-out
- ◆ Wake system up from Power-down mode
- Window Watchdog Timer(WWDT)
  - ◆ 6-bit down counter and 6-bit compare value to make the window period flexible
  - ◆ Selectable WWDT clock pre-scale counter to make WWDT time-out interval variable.
- RTC
  - ◆ Supports software compensation by setting frequency compensate register (FCR)
  - ◆ Supports RTC counter (second, minute, hour) and calendar counter (day, month, year)
  - ◆ Supports Alarm registers (second, minute, hour, day, month, year)
  - ◆ Selectable 12-hour or 24-hour mode
  - ◆ Automatic leap year recognition
  - ◆ Supports periodic time tick interrupt with 8 periodic options 1/128, 1/64, 1/32, 1/16, 1/8, 1/4, 1/2 and 1 second
  - ◆ Wake system up from Power-down mode
  - ◆ Supports 80 bytes spare registers and a snoop pin to clear the content of these spare registers
- PWM/Capture
  - ◆ Supports 2 PWM modules, each has two 16-bit PWM generators
  - ◆ Provides eight PWM outputs or four complementary paired PWM outputs
  - ◆ Each PWM generator equipped with one clock divider, one 8-bit prescaler, two clock selectors, and one Dead-zone generator for complementary paired PWM
  - ◆ (Shared with PWM timers) with eight 16-bit digital capture timers provides eight rising/ falling/both capture inputs.
  - ◆ Supports One-shot and Continuous mode
  - ◆ Supports Capture interrupt
- UART
  - ◆ Up to two 16-byte FIFO UART controllers
  - ◆ UART ports with flow control (TX, RX, CTSn and RTSn)
  - ◆ Supports IrDA (SIR) function
  - ◆ Supports LIN function
  - ◆ Supports RS-485 9 bit mode and direction control.
  - ◆ Programmable baud rate generator
  - ◆ Supports PDMA mode
  - ◆ Wake system up from Power-down mode
- SPI
  - ◆ Up to three sets of SPI controller

- ◆ Master up to 32 MHz, and Slave up to 16 MHz
- ◆ Supports SPI/MICROWIRE Master/Slave mode
- ◆ Full duplex synchronous serial data transfer
- ◆ Variable length of transfer data from 4 to 32 bits
- ◆ MSB or LSB first data transfer
- ◆ RX and TX on both rising or falling edge of serial clock independently
- ◆ Two slave/device select lines when SPI controller is used as the master, and 1 slave/device select line when SPI controller is used as the slave
- ◆ Supports byte suspend mode in 32-bit transmission
- ◆ Supports two channel PDMA requests, one for transmit and another for receive
- ◆ Supports three wire mode, no slave select signal, bi-direction interface
- ◆ Wake system up from Power-down mode
- I<sup>2</sup>C
  - ◆ Up to two sets of I<sup>2</sup>C device
  - ◆ Master/Slave up to 1 Mbit/s
  - ◆ Bi-directional data transfer between masters and slaves
  - ◆ Multi-master bus (no central master)
  - ◆ Arbitration between simultaneously transmitting masters without corruption of serial data on the bus
  - ◆ Serial clock synchronization allows devices with different bit rates to communicate via one serial bus
  - ◆ Serial clock synchronization used as a handshake mechanism to suspend and resume serial transfer
  - ◆ Built-in 14-bit time-out counter requesting the I<sup>2</sup>C interrupt if the I<sup>2</sup>C bus hangs up and timer-out counter overflows
  - ◆ Programmable clocks allowing for versatile rate control
  - ◆ Supports 7-bit addressing mode
  - ◆ Supports multiple address recognition (four slave addresses with mask option)
- I<sup>2</sup>S
  - ◆ Interface with external audio CODEC
  - ◆ Operated as either Master or Slave mode
  - ◆ Capable of handling 8, 16, 24 and 32 bit word sizes
  - ◆ Supports Mono and stereo audio data
  - ◆ Supports I<sup>2</sup>S and MSB justified data format
  - ◆ Provides two 8 word FIFO data buffers: one for transmitting and the other for receiving
  - ◆ Generates interrupt requests when buffer levels cross a programmable boundary
  - ◆ Supports two PDMA requests: one for transmitting and the other for receiving
- ADC

- ◆ 12-bit SAR ADC up to 2Msps conversion rate
- ◆ Up to 12-ch single-ended input from external pin (PA.0 ~ PA.7 and PD.0 ~ PD.3)
- ◆ Six internal channels from DAC0, DAC1, internal reference voltage (Int\_VREF), Temperature sensor, AVDD, and AVSS.
- ◆ Supports three reference voltage sources from VREF pin, internal reference voltage (Int\_VREF), and AVDD.
- ◆ Supports Single Scan, Single Cycle Scan, and Continuous Scan mode
- ◆ Each channel with individual result register
- ◆ Only scan on enabled channels
- ◆ Threshold voltage detection (comparator function)
- ◆ Conversion started by software programming or external input
- ◆ Supports PDMA mode
- ◆ Supports up to four timer time-out events (TMR0, TMR1, TMR2 and TMR3) to enable ADC
- DAC
  - ◆ 12-bit monotonic output with 400K conversion rate
  - ◆ Supports three reference voltage sources from VREF pin, internal reference voltage (Int\_VREF), and AVDD.
  - ◆ Synchronized update capability for two DACs (group function)
  - ◆ Supports up to four timer time-out events (TMR0, TMR1, TMR2 and TMR3), software or PDMA to trigger DAC to conversion
- SmartCard (SC)
  - ◆ Compliant to ISO-7816-3 T=0, T=1
  - ◆ Supports up to three ISO-7816-3 ports
  - ◆ Separates receive/transmit 4 bytes entry FIFO for data payloads
  - ◆ Programmable transmission clock frequency
  - ◆ Programmable receiver buffer trigger level
  - ◆ Programmable guard time selection (11 ETU ~ 266 ETU)
  - ◆ A 24-bit and two 8-bit time-out counters for Answer to Reset (ATR) and waiting times processing
  - ◆ Supports auto inverse convention function
  - ◆ Supports stop clock level and clock stop (clock keep) function
  - ◆ Supports transmitter and receiver error retry and error limit function
  - ◆ Supports hardware activation sequence process
  - ◆ Supports hardware warm reset sequence process
  - ◆ Supports hardware deactivation sequence process
  - ◆ Supports hardware auto deactivation sequence when detect the card is removal
  - ◆ Supports UART mode (Half Duplex)
- EBI (External bus interface) support

- ◆ Accessible space: 64 KB in 8-bit mode or 128 KB in 16-bit mode
- ◆ Supports 8bit/16bit data width
- ◆ Supports byte write in 16-bit Data Width mode
- One built-in temperature sensor with 1°C resolution
- 96-bit unique ID
- 128-bit unique customer ID
- Operating Temperature: -40°C~85°C
- Packages:
  - ◆ All Green package (RoHS)
  - ◆ LQFP 128-pin(14x14) / 64-pin(7x7) / 48-pin(7x7) / QFN 48-pin(7x7)

## 2.2 Nano110 Features – LCD Line

- Core
  - ◆ ARM® Cortex™-M0 core running up to 42 MHz
  - ◆ One 24-bit system timer
  - ◆ Supports Low Power Sleep mode
  - ◆ Single-cycle 32-bit hardware multiplier
  - ◆ NVIC for the 32 interrupt inputs, each with 4-levels of priority
  - ◆ Serial Wire Debug supports with 2 watchpoints/4 breakpoints
- Brown-out
  - ◆ Built-in 2.5V/2.0V/1.7V BOD for wide operating voltage range operation
- Flash EPROM Memory
  - ◆ Runs up to 42 MHz with zero wait state for discontinuous address read access.
  - ◆ 64K/32K/123K bytes application program memory (APROM)
  - ◆ 4 KB In System Programming (ISP) loader program memory (LDROM)
  - ◆ Programmable data flash start address and memory size with 512 bytes page erase unit
  - ◆ In System Program (ISP)/In Application Program (IAP) to update on chip Flash EPROM
- SRAM Memory
  - ◆ 16K/8K bytes embedded SRAM
  - ◆ Supports DMA mode
- DMA : Supports 8 channels: one VDMA channel, 6 PDMA channels, and one CRC channel
  - ◆ VDMA
    - Memory-to-memory transfer
    - Supports block transfer with stride
    - Supports word/half-word/byte boundary address
    - Supports address direction: increment and decrement
  - ◆ PDMA
    - Peripheral-to-memory, memory-to-peripheral, and memory-to-memory transfer
    - Supports word boundary address
    - Supports word alignment transfer length in memory-to-memory mode
    - Supports word/half-word/byte alignment transfer length in peripheral-to-memory and memory-to-peripheral mode
    - Supports word/half-word/byte transfer data width from/to peripheral
    - Supports address direction: increment, fixed, and wrap around
  - ◆ CRC
    - Supports four common polynomials CRC-CCITT, CRC-8, CRC-16, and



CRC-32

- ◆ CRC-CCITT:  $X^{16} + X^{12} + X^5 + 1$
- ◆ CRC-8:  $X^8 + X^2 + X + 1$
- ◆ CRC-16:  $X^{16} + X^{15} + X^2 + 1$
- ◆ CRC-32:  $X^{32} + X^{26} + X^{23} + X^{22} + X^{16} + X^{12} + X^{11} + X^{10} + X^8 + X^7 + X^5 + X^4 + X^2 + X + 1$

- Clock Control
  - ◆ Flexible selection for different applications
  - ◆ Built-in 12 MHz OSC, can be trimmed to 0.25% deviation within all temperature range when turning on auto-trim function (system must have external 32.768 kHz crystal input) otherwise 12 MHz OSC has 2 % deviation within all temperature range.
  - ◆ Low power 10 kHz OSC for watchdog and low power system operation
  - ◆ Supports one PLL, up to 120 MHz, for high performance system operation and USB application (48 MHz).
  - ◆ External 4~24 MHz crystal input for precise timing operation
  - ◆ External 32.768 kHz crystal input for RTC function and low power system operation
- GPIO
  - ◆ Three I/O modes:
    - Push-Pull output
    - Open-Drain output
    - Input only with high impedance
  - ◆ All inputs with Schmitt trigger
  - ◆ I/O pin configured as interrupt source with edge/level setting
  - ◆ Supports High Driver and High Sink I/O mode
  - ◆ Supports input 5V tolerance, except PA.0 ~ PA.7, PD.0 ~ PD.1 and PC.6 ~ PC.7)
- Timer
  - ◆ Supports 4 sets of 32-bit timers, each with 24-bit up-timer and one 8-bit pre-scale counter
  - ◆ Independent Clock Source for each timer
  - ◆ Provides one-shot, periodic, output toggle and continuous operation modes
  - ◆ Internal trigger event to ADC, DAC and PDMA module
  - ◆ Supports PDMA mode
  - ◆ Wake system up from Power-down mode
- Watchdog Timer
  - ◆ Clock Source from LIRC (Internal 10 kHz Low Speed Oscillator Clock)
  - ◆ Selectable time-out period from 1.6 ms ~ 26 sec (depending on clock source)
  - ◆ Interrupt or reset selectable when watchdog time-out

- ◆ Wake system up from Power-down mode
- Window Watchdog Timer(WWDT)
  - ◆ 6-bit down counter and 6-bit compare value to make the window period flexible
  - ◆ Selectable WWDT clock pre-scale counter to make WWDT time-out interval variable.
- RTC
  - ◆ Supports software compensation by setting frequency compensate register (FCR)
  - ◆ Supports RTC counter (second, minute, hour) and calendar counter (day, month, year)
  - ◆ Supports Alarm registers (second, minute, hour, day, month, year)
  - ◆ Selectable 12-hour or 24-hour mode
  - ◆ Automatic leap year recognition
  - ◆ Supports periodic time tick interrupt with 8 periodic options 1/128, 1/64, 1/32, 1/16, 1/8, 1/4, 1/2 and 1 second
  - ◆ Wake system up from Power-down mode
  - ◆ Supports 80 bytes spare registers and a snoop pin to clear the content of these spare registers
- PWM/Capture
  - ◆ Supports 2 PWM modules, each has two 16-bit PWM generators
  - ◆ Provides eight PWM outputs or four complementary paired PWM outputs
  - ◆ Each PWM generator equipped with one clock divider, one 8-bit prescaler, two clock selectors, and one Dead-zone generator for complementary paired PWM
  - ◆ (Shared with PWM timers) with eight 16-bit digital capture timers provides eight rising/ falling/both capture inputs.
  - ◆ Supports Capture interrupt
- UART
  - ◆ Up to two 16-byte FIFO UART controllers
  - ◆ UART ports with flow control (TX, RX, CTSn and RTSn)
  - ◆ Supports IrDA (SIR) function
  - ◆ Supports LIN function
  - ◆ Supports RS-485 9 bit mode and direction control (Low Density Only)
  - ◆ Programmable baud rate generator
  - ◆ Supports PDMA mode
  - ◆ Wake system up from Power-down mode
- SPI
  - ◆ Up to three sets of SPI controller
  - ◆ Master up to 32 MHz, and Slave up to 16 MHz
  - ◆ Supports SPI/MICROWIRE Master/Slave mode
  - ◆ Full duplex synchronous serial data transfer

- ◆ Variable length of transfer data from 4 to 32 bits
- ◆ MSB or LSB first data transfer
- ◆ RX and TX on both rising or falling edge of serial clock independently
- ◆ Two slave/device select lines when SPI controller is as the master, and 1 slave/device select line when SPI controller is as the slave
- ◆ Supports byte suspend mode in 32-bit transmission
- ◆ Supports two channel PDMA requests, one for transmit and another for receive
- ◆ Supports three wire mode, no slave select signal, bi-direction interface
- ◆ Wake system up from Power-down mode
- I<sup>2</sup>C
  - ◆ Up to two sets of I<sup>2</sup>C device
  - ◆ Master/Slave up to 1Mbit/s
  - ◆ Bidirectional data transfer between masters and slaves
  - ◆ Multi-master bus (no central master)
  - ◆ Arbitration between simultaneously transmitting masters without corruption of serial data on the bus
  - ◆ Serial clock synchronization allowing devices with different bit rates to communicate via one serial bus
  - ◆ Serial clock synchronization used as a handshake mechanism to suspend and resume serial transfer
  - ◆ Built-in 14-bit time-out counter requestING the I<sup>2</sup>C interrupt if the I<sup>2</sup>C bus hangs up and timer-out counter overflows
  - ◆ Programmable clocks allow versatile rate control
  - ◆ Supports 7-bit addressing mode
  - ◆ Supports multiple address recognition (four slave address with mask option)
- I<sup>2</sup>S
  - ◆ Interface with external audio CODEC
  - ◆ Operated as either Master or Slave mode
  - ◆ Capable of handling 8, 16, 24 and 32 bit word sizes
  - ◆ Supports Mono and stereo audio data
  - ◆ Supports I<sup>2</sup>S and MSB justified data format
  - ◆ Provides two 8 word FIFO data buffers: one for transmitting and the other for receiving
  - ◆ Generates interrupt requests when buffer levels cross a programmable boundary
  - ◆ Supports two PDMA requests: one for transmitting and the other for receiving
- ADC
  - ◆ 12-bit SAR ADC up to 2Msps conversion rate
  - ◆ Up to 12-ch single-ended input from external pin (PA.0 ~ PA.7 and PD.0 ~ PD.3)
  - ◆ Six internal channels from DAC0, DAC1, internal reference voltage (Int\_VREF),

- ◆ Temperature sensor, AVDD, and AVSS
  - ◆ Supports three reference voltage sources from VREF pin, internal reference voltage (Int\_VREF), and AVDD.
  - ◆ Single scan/single cycle scan/continuous scan
  - ◆ Each channel with individual result register
  - ◆ Only scan on enabled channels
  - ◆ Threshold voltage detection (comparator function)
  - ◆ Conversion start by software programming or external input
  - ◆ Supports PDMA mode
  - ◆ Supports up to four timer time-out events (TMR0, TMR1, TMR2, and TMR3) to enable ADC
- DAC
  - ◆ 12-bit monotonic output with 400K conversion rate
  - ◆ Supports three reference voltage sources from VREF pin, internal reference voltage (Int\_VREF), and AVDD.
  - ◆ Synchronized update capability for two DACs (group function)
  - ◆ Supports up to four timer time-out events (TMR0, TMR1, TMR2 and TMR3), software or PDMA to trigger DAC to conversion
- SmartCard (SC)
  - ◆ Compliant to ISO-7816-3 T=0, T=1
  - ◆ Supports up to three ISO-7816-3 ports
  - ◆ Separates receive / transmit 4 bytes entry FIFO for data payloads
  - ◆ Programmable transmission clock frequency
  - ◆ Programmable receiver buffer trigger level
  - ◆ Programmable guard time selection (11 ETU ~ 266 ETU)
  - ◆ A 24-bit and two 8-bit time-out counter for Answer to Reset (ATR) and waiting times processing
  - ◆ Supports auto inverse convention function
  - ◆ Supports stop clock level and clock stop (clock keep) function
  - ◆ Supports transmitter and receiver error retry and error limit function
  - ◆ Supports hardware activation sequence process
  - ◆ Supports hardware warm reset sequence process
  - ◆ Supports hardware deactivation sequence process
  - ◆ Supports hardware auto deactivation sequence when detect the card is removal
  - ◆ Supports UART mode (Half Duplex)
- LCD
  - ◆ LCD driver for up to 4 COM x 40 SEG or 6 COM x 38 SEG
  - ◆ Supports Static, 1/2 bias and 1/3 bias voltage
  - ◆ Four display modes; Static, 1/2 duty, 1/3 duty, 1/4 duty, 1/5 duty and 1/6 duty.

- ◆ Selectable LCD frequency by frequency divider
- ◆ Configurable frame frequency
- ◆ Internal Charge pump, adjustable contrast adjustment
- ◆ Configurable Charge pump frequency
- ◆ Blinking capability
- ◆ Supports R-type/C-type method
- ◆ LCD frame interrupt
- One built-in temperature sensor with 1 °C resolution
- 96-bit unique ID
- 128-bit unique customer ID
- Operating Temperature: -40°C~85°C
- Packages:
  - ◆ All Green package (RoHS)
  - ◆ LQFP 128-pin(14x14) / 64-pin(10x10) / 64-pin(7x7)

### 2.3 Nano120 Features – USB Connectivity Line

- Core
  - ◆ ARM® Cortex™-M0 core running up to 42 MHz
  - ◆ One 24-bit system timer
  - ◆ Supports Low Power Sleep mode
  - ◆ Single-cycle 32-bit hardware multiplier
  - ◆ NVIC for the 32 interrupt inputs, each with 4-levels of priority
  - ◆ Serial Wire Debug supports with 2 watchpoints/4 breakpoints
- Brown-out
  - ◆ Built-in 2.5V/2.0V/1.7V BOD for wide operating voltage range operation
- Flash EPROM Memory
  - ◆ Runs up to 42 MHz with zero wait state for discontinuous address read access.
  - ◆ 64K/32K/123K bytes application program memory (APROM)
  - ◆ 4KB in system programming (ISP) loader program memory (LDROM)
  - ◆ Programmable data flash start address and memory size with 512 bytes page erase unit
  - ◆ In System Program (ISP)/In Application Program (IAP) to update on chip Flash EPROM
- SRAM Memory
  - ◆ 16K/8K bytes embedded SRAM
  - ◆ Supports PDMA mode
- DMA: Support 8 channels: one VDMA channel, 6 PDMA channels, and one CRC channel
  - ◆ VDMA
    - Memory-to-memory transfer
    - Supports block transfer with stride
    - Supports word/half-word/byte boundary address
    - Supports address direction: increment and decrement
  - ◆ PDMA
    - Peripheral-to-memory, memory-to-peripheral, and memory-to-memory transfer
    - Supports word boundary address
    - Supports word alignment transfer length in memory-to-memory mode
    - Supports word/half-word/byte alignment transfer length in peripheral-to-memory and memory-to-peripheral mode
    - Supports word/half-word/byte transfer data width from/to peripheral
    - Supports address: increment, fixed, and wrap around
  - ◆ CRC
    - Supports four common polynomials CRC-CCITT, CRC-8, CRC-16, and

CRC-32

- ◆ CRC-CCITT:  $X^{16} + X^{12} + X^5 + 1$
- ◆ CRC-8:  $X^8 + X^2 + X + 1$
- ◆ CRC-16:  $X^{16} + X^{15} + X^2 + 1$
- ◆ CRC-32:  $X^{32} + X^{26} + X^{23} + X^{22} + X^{16} + X^{12} + X^{11} + X^{10} + X^8 + X^7 + X^5 + X^4 + X^2 + X + 1$

- Clock Control
  - ◆ Flexible selection for different applications
  - ◆ Built-in 12MHz OSC, can be trimmed to 0.25% deviation within all temperature range when turning on auto-trim function (system must have external 32.768 kHz crystal input) otherwise 12 MHz OSC has 2 % deviation within all temperature range
  - ◆ Low power 10 kHz OSC for watchdog and low power system operation
  - ◆ Supports one PLL, up to 120 MHz, for high performance system operation and USB application (48 MHz).
  - ◆ External 4~24 MHz crystal input for precise timing operation
  - ◆ External 32.768 kHz crystal input for RTC function and low power system operation
- GPIO
  - ◆ Three I/O modes:
    - Push-Pull output
    - Open-Drain output
    - Input only with high impedance
  - ◆ All inputs with Schmitt trigger
  - ◆ I/O pin can be configured as interrupt source with edge/level setting
  - ◆ High driver and high sink IO mode support
  - ◆ Supports input 5V tolerance (except ADC and DAC shared pins)
- Timer
  - ◆ Supports 4 sets of 32-bit timers, each with 24-bit up-timer and one 8-bit pre-scale counter
  - ◆ Independent Clock Source for each timer
  - ◆ Provides one-shot, periodic, output toggle and continuous operation modes
  - ◆ Internal trigger event to ADC, DAC and PDMA module
  - ◆ Supports PDMA mode
  - ◆ Wake system up from Power-down mode
- Watchdog Timer
  - ◆ Clock Source from LIRC. (Internal 10 kHz Low Speed Oscillator Clock)
  - ◆ Selectable time-out period from 1.6 ms ~ 26 sec (depending on clock source)
  - ◆ Interrupt or reset selectable on watchdog time-out
  - ◆ Wake system up from Power-down mode

- Window Watchdog Timer(WWDT)
  - ◆ 6-bit down counter and 6-bit compare value to make the window period flexible
  - ◆ Selectable WWDT clock pre-scale counter to make WWDT time-out interval variable.
- RTC
  - ◆ Supports software compensation by setting frequency compensate register (FCR)
  - ◆ Supports RTC counter (second, minute, hour) and calendar counter (day, month, year)
  - ◆ Supports Alarm registers (second, minute, hour, day, month, year)
  - ◆ Selectable 12-hour or 24-hour mode
  - ◆ Automatic leap year recognition
  - ◆ Supports periodic time tick interrupt with 8 periodic options 1/128, 1/64, 1/32, 1/16, 1/8, 1/4, 1/2 and 1 second
  - ◆ Wake system up from Power-down or Idle mode
  - ◆ Support 80 bytes spare registers and a snoop pin to clear the content of these spare registers
- PWM/Capture
  - ◆ Supports 2 PWM module, each has two 16-bit PWM generators
  - ◆ Provide eight PWM outputs or four complementary paired PWM outputs
  - ◆ Each PWM generator equipped with one clock divider, one 8-bit prescaler, two clock selectors, and one Dead-Zone generator for complementary paired PWM
  - ◆ (Shared with PWM timers) with eight 16-bit digital capture timers provides eight rising/ falling/both capture inputs.
  - ◆ Supports one shot and continuous mode
  - ◆ Supports Capture interrupt
- UART
  - ◆ Up to two 16-byte FIFO UART controllers
  - ◆ UART ports with flow control (TX, RX, CTSn and RTSn)
  - ◆ Supports IrDA (SIR) function
  - ◆ Supports LIN function
  - ◆ Supports RS-485 9 bit mode and direction control. (Low Density Only)
  - ◆ Programmable baud rate generator
  - ◆ Supports PDMA mode
  - ◆ Wake system up from Power-down mode
- SPI
  - ◆ Up to three sets of SPI controller
  - ◆ Master up to 32 MHz, and Slave up to 16 MHz
  - ◆ Supports SPI/MICROWIRE Master/Slave mode
  - ◆ Full duplex synchronous serial data transfer



- ◆ Variable length of transfer data from 4 to 32 bits
- ◆ MSB or LSB first data transfer
- ◆ RX and TX on both rising or falling edge of serial clock independently
- ◆ Two slave/device select lines when SPI controller is as the master, and 1 slave/device select line when SPI controller is as the slave
- ◆ Supports byte suspend mode in 32-bit transmission
- ◆ Supports two channel PDMA requests, one for transmit and another for receive
- ◆ Supports three wire, no slave select signal, bi-direction interface
- ◆ Wake system up from Power-down mode
- I<sup>2</sup>C
  - ◆ Up to two sets of I<sup>2</sup>C device
  - ◆ Master/Slave up to 1Mbit/s
  - ◆ Bi-directional data transfer between masters and slaves
  - ◆ Multi-master bus (no central master)
  - ◆ Arbitration between simultaneously transmitting masters without corruption of serial data on the bus
  - ◆ Serial clock synchronization allowing devices with different bit rates to communicate via one serial bus
  - ◆ Serial clock synchronization used as a handshake mechanism to suspend and resume serial transfer
  - ◆ Built-in 14-bit time-out counter requesting the I<sup>2</sup>C interrupt if the I<sup>2</sup>C bus hangs up and timer-out counter overflows
  - ◆ Programmable clocks allow versatile rate control
  - ◆ Supports 7-bit addressing mode
  - ◆ Supports multiple address recognition (four slave addresses with mask option)
- I<sup>2</sup>S
  - ◆ Interface with external audio CODEC
  - ◆ Operated as either Master or Slave mode
  - ◆ Capable of handling 8, 16, 24 and 32 bit word sizes
  - ◆ Supports Mono and stereo audio data
  - ◆ Supports I<sup>2</sup>S and MSB justified data format
  - ◆ Provides two 8 word FIFO data buffers: one for transmitting and the other for receiving
  - ◆ Generates interrupt requests when buffer levels cross a programmable boundary
  - ◆ Supports two PDMA requests: one for transmitting and the other for receiving
- ADC
  - ◆ 12-bit SAR ADC up to 2Msps conversion rate
  - ◆ Up to 12-ch single-ended input from external pin (PA.0 ~ PA.7 and PD.0 ~ PD.3).

- ◆ Six internal channels from DAC0, DAC1, internal reference voltage (Int\_VREF), Temperature sensor, AVDD, and AVSS.
- ◆ Supports three reference voltage sources from VREF pin, internal reference voltage (Int\_VREF), and AVDD
- ◆ Supports single scan, single cycle scan, and continuous scan modes
- ◆ Each channel with individual result register
- ◆ Only scan on enabled channels
- ◆ Threshold voltage detection (comparator function)
- ◆ Conversion start by software programming or external input
- ◆ Supports PDMA mode
- ◆ Supports up to four timer time-out events (TMR0, TMR1, TMR2 and TMR3) to enable ADC
- DAC
  - ◆ 12-bit monotonic output with 400K conversion rate
  - ◆ Supports three reference voltage sources from VREF pin, internal reference voltage (Int\_VREF), and AVDD.
  - ◆ Synchronized update capability for two DACs (group function)
  - ◆ Supports up to four timer time-out event (TMR0, TMR1, TMR2 and TMR3), software or PDMA to trigger DAC to conversion
- SmartCard (SC)
  - ◆ Compliant to ISO-7816-3 T=0, T=1
  - ◆ Supports up to three ISO-7816-3 ports
  - ◆ Separates receive / transmit 4 bytes entry FIFO for data payloads
  - ◆ Programmable transmission clock frequency
  - ◆ Programmable receiver buffer trigger level
  - ◆ Programmable guard time selection (11 ETU ~ 266 ETU)
  - ◆ A 24-bit and two 8-bit time-out counter for Answer to Reset (ATR) and waiting times processing
  - ◆ Supports auto inverse convention function
  - ◆ Supports stop clock level and clock stop (clock keep) function
  - ◆ Supports transmitter and receiver error retry and error limit function
  - ◆ Supports hardware activation sequence process
  - ◆ Supports hardware warm reset sequence process
  - ◆ Supports hardware deactivation sequence process
  - ◆ Supports hardware auto deactivation sequence when detect the card is removal
  - ◆ Supports UART mode (Half Duplex)
- USB 2.0 Full-Speed Device
  - ◆ One set of USB 2.0 FS Device 12 Mbps
  - ◆ On-chip USB Transceiver

- ◆ Provides 1 interrupt source with 4 interrupt events
- ◆ Supports Control, Bulk In/Out, Interrupt and Isochronous transfers
- ◆ Auto suspend function when no bus signaling for 3 ms
- ◆ Provides 8 programmable endpoints
- ◆ Includes 512 Bytes internal SRAM as USB buffer
- ◆ Provides remote wake-up capability
- EBI (External bus interface) support
  - ◆ Accessible space: 64 KB in 8-bit mode or 128 KB in 16-bit mode
  - ◆ Supports 8bit/16bit data width
  - ◆ Supports byte write in 16-bit Data Width mode
- One built-in temperature sensor with 1 °C resolution
- 96-bit unique ID
- 128-bit unique customer ID
- Operating Temperature: -40°C~85°C
- Packages:
  - ◆ All Green package (RoHS)
  - ◆ LQFP 128-pin(14x14) / 64-pin(7x7) / 48-pin(7x7)

## 2.4 Nano130 Features – Advanced Line

- Core
  - ◆ ARM® Cortex™-M0 core running up to 42 MHz
  - ◆ One 24-bit system timer
  - ◆ Supports Low Power Sleep mode
  - ◆ Single-cycle 32-bit hardware multiplier
  - ◆ NVIC for the 32 interrupt inputs, each with 4-levels of priority
  - ◆ Serial Wire Debug supports with 2 watchpoints/4 breakpoints
- Brown-out
  - ◆ Built-in 2.5V/2.0V/1.7V BOD for wide operating voltage range operation
- Flash EPROM Memory
  - ◆ Runs up to 42 MHz with zero wait state for discontinuous address read access.
  - ◆ 64K/32K/123K bytes application program memory (APROM)
  - ◆ 4KB in system programming (ISP) loader program memory (LDROM)
  - ◆ Programmable data flash start address and memory size with 512 bytes page erase unit
  - ◆ In System Program (ISP)/In Application Program (IAP) to update on chip Flash EPROM
- SRAM Memory
  - ◆ 16K/8K bytes embedded SRAM
  - ◆ Supports DMA mode
- DMA : Supports 8 channels: one VDMA channel, 6 PDMA channels, and one CRC egiste
  - ◆ VDMA
    - Memory-to-memory transfer
    - Supports block transfer with stride
    - Supports word/half-word/byte boundary address
    - Supports address direction: increment and decrement
  - ◆ PDMA
    - Peripheral-to-memory, memory-to-peripheral, and memory-to-memory transfer
    - Supports word boundary address
    - Supports word alignment transfer length in memory-to-memory mode
    - Supports word/half-word/byte alignment transfer length in peripheral-to-memory and memory-to-peripheral mode
    - Supports word/half-word/byte transfer data width from/to peripheral
    - Supports address direction: increment, fixed, and wrap around
  - ◆ CRC
    - Supports four common polynomials CRC-CCITT, CRC-8, CRC-16, and

CRC-32

- ◆ CRC-CCITT:  $X^{16} + X^{12} + X^5 + 1$
- ◆ CRC-8:  $X^8 + X^2 + X + 1$
- ◆ CRC-16:  $X^{16} + X^{15} + X^2 + 1$
- ◆ CRC-32:  $X^{32} + X^{26} + X^{23} + X^{22} + X^{16} + X^{12} + X^{11} + X^{10} + X^8 + X^7 + X^5 + X^4 + X^2 + X + 1$

- Clock Control
  - ◆ Flexible selection for different applications
  - ◆ Built-in 12MHz OSC, can be trimmed to 0.25% deviation within all temperature range when turning on auto-trim function (system must have external 32.768 kHz crystal input) otherwise 12 MHz OSC has 2 % deviation within all temperature range.
  - ◆ Low power 10 kHz OSC for watchdog and low power system operation
  - ◆ Supports one PLL, up to 120 MHz, for high performance system operation and USB application (48 MHz).
  - ◆ External 4~24 MHz crystal input for precise timing operation
  - ◆ External 32.768 kHz crystal input for RTC function and low power system operation
- GPIO
  - ◆ Three I/O modes:
    - Push-Pull output
    - Open-Drain output
    - Input only with high impedance
  - ◆ All inputs with Schmitt trigger
  - ◆ I/O pin configured as interrupt source with edge/level setting
  - ◆ Supports High Driver and High Sink I/O mode
  - ◆ Supports input 5V tolerance (except ADC and DAC shared pins)
- Timer
  - ◆ Supports 4 sets of 32-bit timers with 24-bit up-timer and one 8-bit pre-scale counter
  - ◆ Independent Clock Source for each timer
  - ◆ Provides one-shot,periodic, output toggle and continuous operation modes
  - ◆ Supports internal trigger event to ADC, DAC and PDMA module
  - ◆ Wake system up from Power-down mode
- Watchdog Timer
  - ◆ Clock Source is from LIRC. (Internal 10 kHz Low Speed Oscillator Clock)
  - ◆ Selectable time-out period from 1.6ms ~ 26sec (depends on clock source)
  - ◆ Interrupt or reset selectable on watchdog time-out
  - ◆ WDT can wake system up from Power-down mode
- Window Watchdog Timer(WWDT)

- ◆ 6-bit down counter and 6-bit compare value to make the window period flexible
- ◆ Selectable WWDT clock pre-scale counter to make WWDT time-out interval variable.
- RTC
  - ◆ Supports software compensation by setting frequency compensate register (FCR)
  - ◆ Supports RTC counter (second, minute, hour) and calendar counter (day, month, year)
  - ◆ Supports Alarm registers (second, minute, hour, day, month, year)
  - ◆ Selectable 12-hour or 24-hour mode
  - ◆ Automatic leap year recognition
  - ◆ Supports periodic time tick interrupt with 8 periodic options 1/128, 1/64, 1/32, 1/16, 1/8, 1/4, 1/2 and 1 second
  - ◆ Wake system up from Power-down or Idle mode
  - ◆ Supports 80 bytes spare registers and a snoop pin to clear the content of these spare registers
- PWM/Capture
  - ◆ Supports 2 PWM module, each with two 16-bit PWM generators
  - ◆ Provides eight PWM outputs or four complementary paired PWM outputs
  - ◆ Each PWM generator equipped with one clock divider, one 8-bit prescaler, two clock selectors, and one Dead-Zone generator for complementary paired PWM
  - ◆ (Shared with PWM timers) with eight 16-bit digital capture timers provides eight rising/ falling/both capture inputs.
  - ◆ Supports Capture interrupt
- UART
  - ◆ Up to two 16-byte FIFO UART controllers
  - ◆ UART ports with flow control (TX, RX, CTSn and RTSn)
  - ◆ Supports IrDA (SIR) function
  - ◆ Supports LIN function
  - ◆ Supports RS-485 9 bit mode and direction control (Low Density Only)
  - ◆ Programmable baud rate generator
  - ◆ Supports PDMA mode
  - ◆ Wake system up from Power-down or Idle mode
- SPI
  - ◆ Up to 3 sets of SPI controller
  - ◆ Master up to 32 MHz, and Slave up to 16 MHz
  - ◆ Supports SPI/MICROWIRE Master/Slave mode
  - ◆ Full duplex synchronous serial data transfer
  - ◆ Variable length of transfer data from 4 to 32 bits
  - ◆ MSB or LSB first data transfer

- ◆ RX and TX on both rising or falling edge of serial clock independently
- ◆ Two slave/device select lines when used as the master, and 1 slave/device select line when used as the slave
- ◆ Supports byte suspend mode in 32-bit transmission
- ◆ Supports two channel PDMA request, one for transmit and another for receive
- ◆ Supports three wire, no slave select signal, bi-direction interface
- ◆ Wake system up from Power-down or Idle mode
- I<sup>2</sup>C
  - ◆ Up to two sets of I<sup>2</sup>C device
  - ◆ Master/Slave up to 1Mbit/s
  - ◆ Bi-directional data transfer between masters and slaves
  - ◆ Multi-master bus (no central master)
  - ◆ Arbitration between simultaneously transmitting masters without corruption of serial data on the bus
  - ◆ Serial clock synchronization allowing devices with different bit rates to communicate via one serial bus
  - ◆ Serial clock synchronization can be used as a handshake mechanism to suspend and resume serial transfer
  - ◆ Built-in 14-bit time-out counter will request the I<sup>2</sup>C interrupt if the I<sup>2</sup>C bus hangs up and timer-out counter overflows
  - ◆ Programmable clocks allowing for versatile rate control
  - ◆ Supports 7-bit addressing mode
  - ◆ Supports multiple address recognition (four slave addresses with mask option)
- I<sup>2</sup>S
  - ◆ Interface with external audio CODEC
  - ◆ Operate as either Master or Slave mode
  - ◆ Capable of handling 8, 16, 24 and 32 bit word sizes
  - ◆ Supports Mono and stereo audio data
  - ◆ Supports I<sup>2</sup>S and MSB justified data format
  - ◆ Provides two 8 word FIFO data buffers: one for transmitting and the other for receiving
  - ◆ Generates interrupt requests when buffer levels cross a programmable boundary
  - ◆ Supports two PDMA requests: one for transmitting and the other for receiving
- ADC
  - ◆ 12-bit SAR ADC up to 2Msps conversion rate
  - ◆ Up to 12-ch single-ended input from external pin (PA.0 ~ PA.7 and PD.0 ~ PD.3)
  - ◆ Six internal channels from DAC0, DAC1, internal reference voltage (Int\_VREF), Temperature sensor, AVDD, and AVSS.
  - ◆ Supports three reference voltage sources from VREF pin, internal reference

- ◆ voltage (Int\_VREF), and AVDD
  - ◆ Single scan/single cycle scan/continuous scan
  - ◆ Each channel with individual result register
  - ◆ Scan on enabled channels
  - ◆ Threshold voltage detection (comparator function)
  - ◆ Conversion start by software programming or external input
  - ◆ Supports PDMA mode
  - ◆ Supports up to four timer time-out events (TMR0, TMR1, TMR2 and TMR3) to enable ADC
- DAC
  - ◆ 12-bit monotonic output with 400K conversion rate
  - ◆ Supports three reference voltage sources from VREF pin, internal reference voltage (Int\_VREF), and AVDD.
  - ◆ Synchronized update capability for two DACs (group function)
  - ◆ Supports up to four timer time-out events (TMR0, TMR1, TMR2 and TMR3), software or PDMA to trigger DAC to conversion
- SmartCard (SC)
  - ◆ Compliant to ISO-7816-3 T=0, T=1
  - ◆ Supports up to three ISO-7816-3 ports
  - ◆ Separates receive/transmit 4 bytes entry FIFO for data payloads
  - ◆ Programmable transmission clock frequency
  - ◆ Programmable receiver buffer trigger level
  - ◆ Programmable guard time selection (11 ETU ~ 266 ETU)
  - ◆ A 24-bit and two 8-bit time-out counter for Answer to Reset (ATR) and waiting times processing
  - ◆ Supports auto inverse convention function
  - ◆ Supports stop clock level and clock stop (clock keep) function
  - ◆ Supports transmitter and receiver error retry and error limit function
  - ◆ Supports hardware activation sequence process
  - ◆ Supports hardware warm reset sequence process
  - ◆ Supports hardware deactivation sequence process
  - ◆ Supports hardware auto deactivation sequence when detecting the card is removed
  - ◆ Support UART mode (Half Duplex)
- LCD
  - ◆ LCD driver for up to 4 COM x 40 SEG or 6 COM x 38 SEG
  - ◆ Supports Static, 1/2 bias and 1/3 bias voltage
  - ◆ Four display modes: Static, 1/2 duty, 1/3 duty, 1/4 duty, 1/5 duty and 1/6 duty.
  - ◆ Selectable LCD frequency by frequency divider



- ◆ Configurable frame frequency
- ◆ Internal Charge pump, adjustable contrast adjustment
- ◆ Configurable Charge pump frequency
- ◆ Blinking capability
- ◆ Supports R-type/C-type method
- ◆ LCD frame interrupt
- USB 2.0 Full-speed Device
  - ◆ One set of USB 2.0 FS Device 12 Mbps
  - ◆ On-chip USB Transceiver
  - ◆ Provides 1 interrupt source with 4 interrupt events
  - ◆ Supports Control, Bulk In/Out, Interrupt and Isochronous transfers
  - ◆ Auto suspend function when no bus signaling for 3 ms
  - ◆ Provides 8 programmable endpoints
  - ◆ Includes 512 Bytes internal SRAM as USB buffer
  - ◆ Provides remote wake-up capability
- EBI (External bus interface)
  - ◆ Accessible space: 64 KB in 8-bit mode or 128 KB in 16-bit mode
  - ◆ Supports 8bit/16bit data width
  - ◆ Supports byte write in 16-bit data width mode
- One built-in temperature sensor with 1 °C resolution
- 96-bit unique ID
- 128-bit unique customer ID
- Operating Temperature: -40°C~85°C
- Packages:
  - ◆ All Green package (RoHS)
  - ◆ LQFP 128-pin(14x14) / 64-pin (7x7)

### 3 PARTS INFORMATION LIST AND PIN CONFIGURATION

#### 3.1 NuMicro® Nano100 Series Selection Code

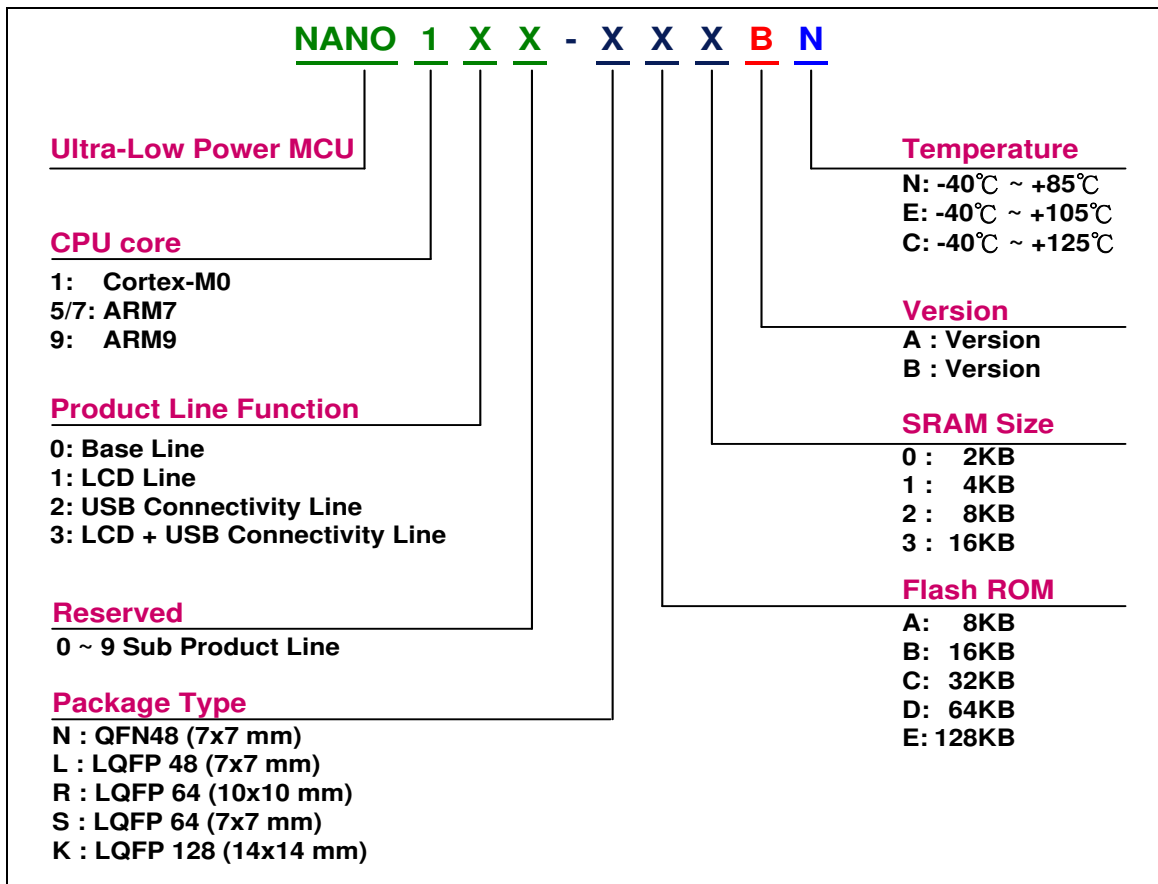

Figure 3-1 NuMicro® Nano100 Series Selection Code

### 3.2 NuMicro® Nano100 Products Selection Guide

#### 3.2.1 NuMicro® Nano100 Base Line Selection Guide

Part No.	Flash (Kbytes)	SRAM (Kbytes)	Data Flash (Kbytes)	ISP ROM (Kbytes)	I/O	Timer (32-bit)	Connectivity				I <sup>2</sup> S	PWM (16-bit)	ADC (12-bit)	RTC	EBI	PDMA	LCD	DAC (12-bit)	ISO-7816-3*	ICP ISP IAP	IRC 10KHz 12MHz	Package	Operating Temp. Range (°C)
							UART*	SPI	I <sup>2</sup> C	USB													
NANO100NC2BN	32	8	Configurable	4	38	4	2+2	3	2	-	1	6	7	√	-	8	-	2	2	√	√	QFN48	-40 to +85
NANO100ND2BN	64	8	Configurable	4	38	4	2+2	3	2	-	1	6	7	√	-	8	-	2	2	√	√	QFN48	-40 to +85
NANO100ND3BN	64	16	Configurable	4	38	4	2+2	3	2	-	1	6	7	√	-	8	-	2	2	√	√	QFN48	-40 to +85
NANO100NE3BN	128	16	Configurable	4	38	4	2+2	3	2	-	1	6	7	√	-	8	-	2	2	√	√	QFN48	-40 to +85
NANO100LC2BN	32	8	Configurable	4	38	4	2+2	3	2	-	1	6	7	√	-	8	-	2	2	√	√	LQFP48	-40 to +85
NANO100LD2BN	64	8	Configurable	4	38	4	2+2	3	2	-	1	6	7	√	-	8	-	2	2	√	√	LQFP48	-40 to +85
NANO100LD3BN	64	16	Configurable	4	38	4	2+2	3	2	-	1	6	7	√	-	8	-	2	2	√	√	LQFP48	-40 to +85
NANO100LE3BN	128	16	Configurable	4	38	4	2+2	3	2	-	1	6	7	√	-	8	-	2	2	√	√	LQFP48	-40 to +85
NANO100SC2BN	32	8	Configurable	4	52	4	2+3	3	2	-	1	8	7	√	-	8	-	2	3	√	√	LQFP64*	-40 to +85
NANO100SD2BN	64	8	Configurable	4	52	4	2+3	3	2	-	1	8	7	√	-	8	-	2	3	√	√	LQFP64*	-40 to +85
NANO100SD3BN	64	16	Configurable	4	52	4	2+3	3	2	-	1	8	7	√	-	8	-	2	3	√	√	LQFP64*	-40 to +85
NANO100SE3BN	128	16	Configurable	4	52	4	2+3	3	2	-	1	8	7	√	-	8	-	2	3	√	√	LQFP64*	-40 to +85
NANO100KD3BN	64	16	Configurable	4	86	4	2+3	3	2	-	1	8	12	√	√	8	-	2	3	√	√	LQFP128	-40 to +85
NANO100KE3BN	128	16	Configurable	4	86	4	2+3	3	2	-	1	8	12	√	√	8	-	2	3	√	√	LQFP128	-40 to +85

\*Marked in the table (2+3) means 2 UART+ 3 ISO-7816 UART.

LQFP64\*:7X7mm

\*ISO-7816 UART supports half duplex mode.

Table 3-1 Nano100 Base Line Selection Table

#### 3.2.2 NuMicro® Nano110 LCD Line Selection Guide

Part No.	Flash (Kbytes)	SRAM (Kbytes)	Data Flash (Kbytes)	ISP ROM (Kbytes)	I/O	Timer (32-bit)	Connectivity				I <sup>2</sup> S	PWM (16-bit)	ADC (12-bit)	RTC	EBI	PDMA	LCD	DAC (12-bit)	ISO-7816-3*	ICP ISP IAP	IRC 10KHz 12MHz	Package	Operating Temp. Range (°C)
							UART*	SPI	I <sup>2</sup> C	USB													
NANO110SC2BN	32	8	Configurable	4	51	4	2+3	3	2	-	1	7	7	√	-	8	4x31, 6x29	2	3	√	√	LQFP64*	-40 to +85
NANO110SD2BN	64	8	Configurable	4	51	4	2+3	3	2	-	1	7	7	√	-	8	4x31, 6x29	2	3	√	√	LQFP64*	-40 to +85
NANO110SD3BN	64	16	Configurable	4	51	4	2+3	3	2	-	1	7	7	√	-	8	4x31, 6x29	2	3	√	√	LQFP64*	-40 to +85
NANO110SE3BN	128	16	Configurable	4	51	4	2+3	3	2	-	1	7	7	√	-	8	4x31, 6x29	2	3	√	√	LQFP64*	-40 to +85
NANO110RC2BN	32	8	Configurable	4	51	4	2+3	3	2	-	1	7	7	√	-	8	4x31, 6x29	2	3	√	√	LQFP64	-40 to +85
NANO110RD2BN	64	8	Configurable	4	51	4	2+3	3	2	-	1	7	7	√	-	8	4x31, 6x29	2	3	√	√	LQFP64	-40 to +85
NANO110RD3BN	64	16	Configurable	4	51	4	2+3	3	2	-	1	7	7	√	-	8	4x31, 6x29	2	3	√	√	LQFP64	-40 to +85
NANO110RE3BN	128	16	Configurable	4	51	4	2+3	3	2	-	1	7	7	√	-	8	4x31, 6x29	2	3	√	√	LQFP64	-40 to +85
NANO110KC2BN	32	8	Configurable	4	86	4	2+3	3	2	-	1	8	12	√	√	8	4x40, 6x38	2	3	√	√	LQFP128	-40 to +85
NANO110KD2BN	64	8	Configurable	4	86	4	2+3	3	2	-	1	8	12	√	√	8	4x40, 6x38	2	3	√	√	LQFP128	-40 to +85
NANO110KD3BN	64	16	Configurable	4	86	4	2+3	3	2	-	1	8	12	√	√	8	4x40, 6x38	2	3	√	√	LQFP128	-40 to +85
NANO110KE3BN	128	16	Configurable	4	86	4	2+3	3	2	-	1	8	12	√	√	8	4x40, 6x38	2	3	√	√	LQFP128	-40 to +85

\*Marked in the table (2+3) means 2 UART+ 3 ISO-7816 UART.

LQFP64\*:7X7mm

\*ISO-7816 UART supports half duplex mode.

Table 3-2 Nano110 LCD Line Selection Table

#### 3.2.3 NuMicro® Nano120 USB Connectivity Line Selection Guide

Part No.	Flash (Kbytes)	SRAM (Kbytes)	Data Flash (Kbytes)	ISP ROM (Kbytes)	I/O	Timer (32-bit)	Connectivity				I <sup>2</sup> S	PWM (16-bit)	ADC (12-bit)	RTC	EBI	PDMA	LCD	DAC (12-bit)	ISO-7816-3*	ICP ISP IAP	IRC 10KHz 12MHz	Package	Operating Temp. Range (°C)
							UART*	SPI	I <sup>2</sup> C	USB													
NANO120LC2BN	32	8	Configurable	4	34	4	2+2	3	2	1	1	4	7	√	-	8	-	2	2	√	√	LQFP48	-40 to +85
NANO120LD2BN	64	8	Configurable	4	34	4	2+2	3	2	1	1	4	7	√	-	8	-	2	2	√	√	LQFP48	-40 to +85
NANO120LD3BN	64	16	Configurable	4	34	4	2+2	3	2	1	1	4	7	√	-	8	-	2	2	√	√	LQFP48	-40 to +85
NANO120LE3BN	128	16	Configurable	4	34	4	2+2	3	2	1	1	4	7	√	-	8	-	2	2	√	√	LQFP48	-40 to +85
NANO120SC2BN	32	8	Configurable	4	48	4	2+3	3	2	1	1	8	7	√	-	8	-	2	3	√	√	LQFP64*	-40 to +85
NANO120SD2BN	64	8	Configurable	4	48	4	2+3	3	2	1	1	8	7	√	-	8	-	2	3	√	√	LQFP64*	-40 to +85
NANO120SD3BN	64	16	Configurable	4	48	4	2+3	3	2	1	1	8	7	√	-	8	-	2	3	√	√	LQFP64*	-40 to +85
NANO120SE3BN	128	16	Configurable	4	48	4	2+3	3	2	1	1	8	7	√	-	8	-	2	3	√	√	LQFP64*	-40 to +85
NANO120KD3BN	64	16	Configurable	4	86	4	2+3	3	2	1	1	8	8	√	√	8	-	2	3	√	√	LQFP128	-40 to +85
NANO120KE3BN	128	16	Configurable	4	86	4	2+3	3	2	1	1	8	8	√	√	8	-	2	3	√	√	LQFP128	-40 to +85

\*Marked in the table (2+3) means 2 UART+ 3 ISO-7816 UART.

LQFP64\*:7X7mm

\*ISO-7816 UART supports half duplex mode.

Table 3-3 Nano120 USB Connectivity Line Selection Table

3.2.4 NuMicro® Nano130 Advanced Line Selection Guide

Part No.	Flash (Kbytes)	SRAM (Kbytes)	Data Flash (Kbytes)	ISP ROM (Kbytes)	I/O	Timer (32-bit)	Connectivity				I <sup>2</sup> S	PWM (16-bit)	ADC (12-bit)	RTC	EBI	PDMA	LCD	DAC (12-bit)	ISO-7816-3*	ICP ISP IAP	IRC 10KHz 12MHz	Package	Operating Temp. Range (°C)
							UART*	SPI	I <sup>2</sup> C	USB													
NANO130SC2BN	32	8	Configurable	4	47	4	2+3	3	2	1	1	7	7	√	-	8	4x31, 6x29	2	3	√	√	LQFP64*	-40 to +85
NANO130SD2BN	64	8	Configurable	4	47	4	2+3	3	2	1	1	7	7	√	-	8	4x31, 6x29	2	3	√	√	LQFP64*	-40 to +85
NANO130SD3BN	64	16	Configurable	4	47	4	2+3	3	2	1	1	7	7	√	-	8	4x31, 6x29	2	3	√	√	LQFP64*	-40 to +85
NANO130SE3BN	128	16	Configurable	4	47	4	2+3	3	2	1	1	7	7	√	-	8	4x31, 6x29	2	3	√	√	LQFP64*	-40 to +85
NANO130KC2BN	32	8	Configurable	4	86	4	2+3	3	2	1	1	8	8	√	√	8	4x40, 6x38	2	3	√	√	LQFP128	-40 to +85
NANO130KD2BN	64	8	Configurable	4	86	4	2+3	3	2	1	1	8	8	√	√	8	4x40, 6x38	2	3	√	√	LQFP128	-40 to +85
NANO130KD3BN	64	16	Configurable	4	86	4	2+3	3	2	1	1	8	8	√	√	8	4x40, 6x38	2	3	√	√	LQFP128	-40 to +85
NANO130KE3BN	128	16	Configurable	4	86	4	2+3	3	2	1	1	8	8	√	√	8	4x40, 6x38	2	3	√	√	LQFP128	-40 to +85

\*Marked in the table (2+3) means 2 UART+ 3 ISO-7816 UART.

LQFP64\*:7X7mm

\*ISO-7816 UART supports half duplex mode.

Table 3-4 Nano130 Advanced Line Selection Table

### 3.3 Pin Configuration

#### 3.3.1 NuMicro® Nano100 Pin Diagrams

##### 3.3.1.1 NuMicro® Nano100 LQFP 128-pin

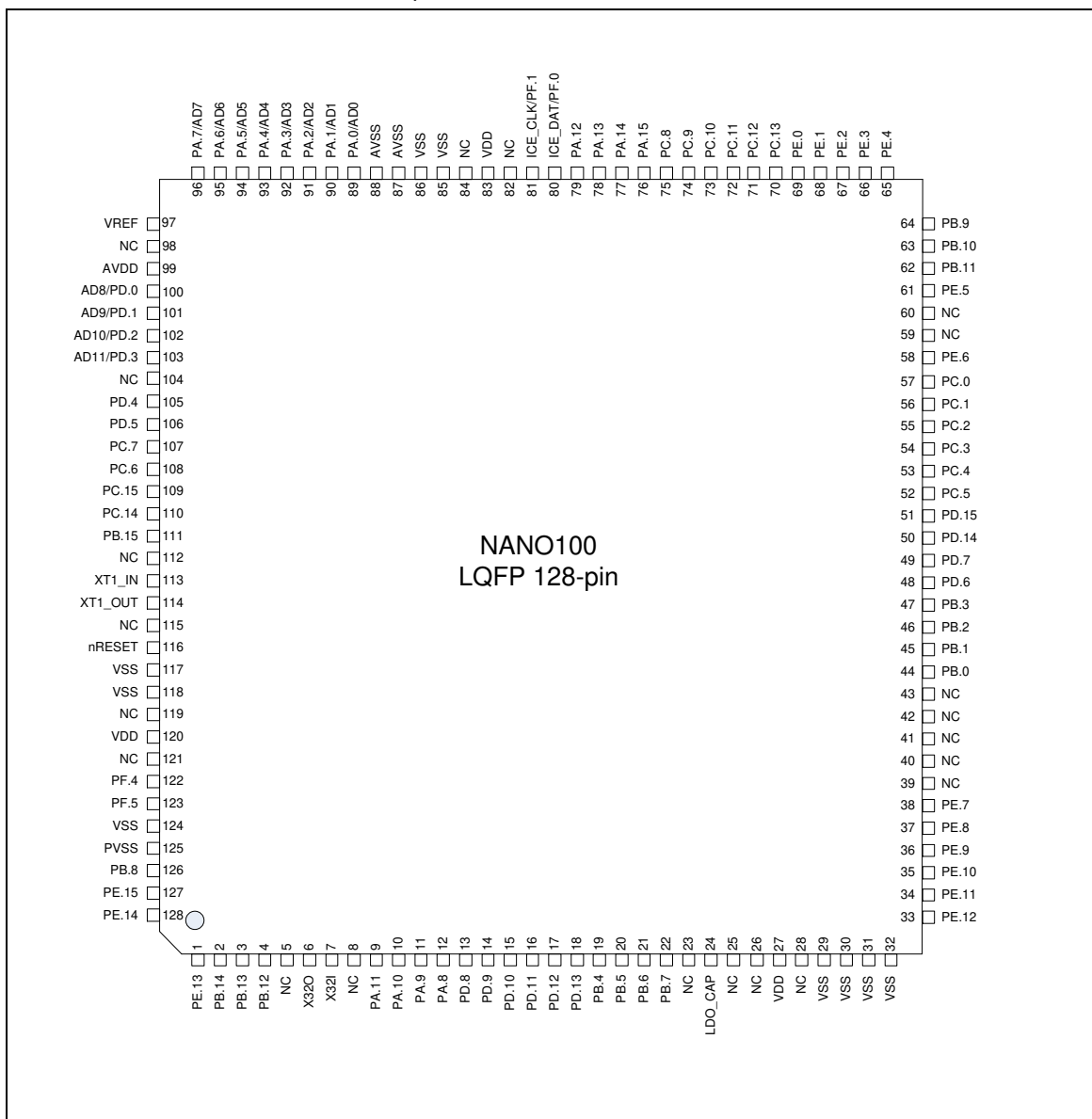

Figure 3-2 NuMicro® Nano100 LQFP 128-pin Diagram

3.3.1.2 NuMicro® Nano100 LQFP 64-pin

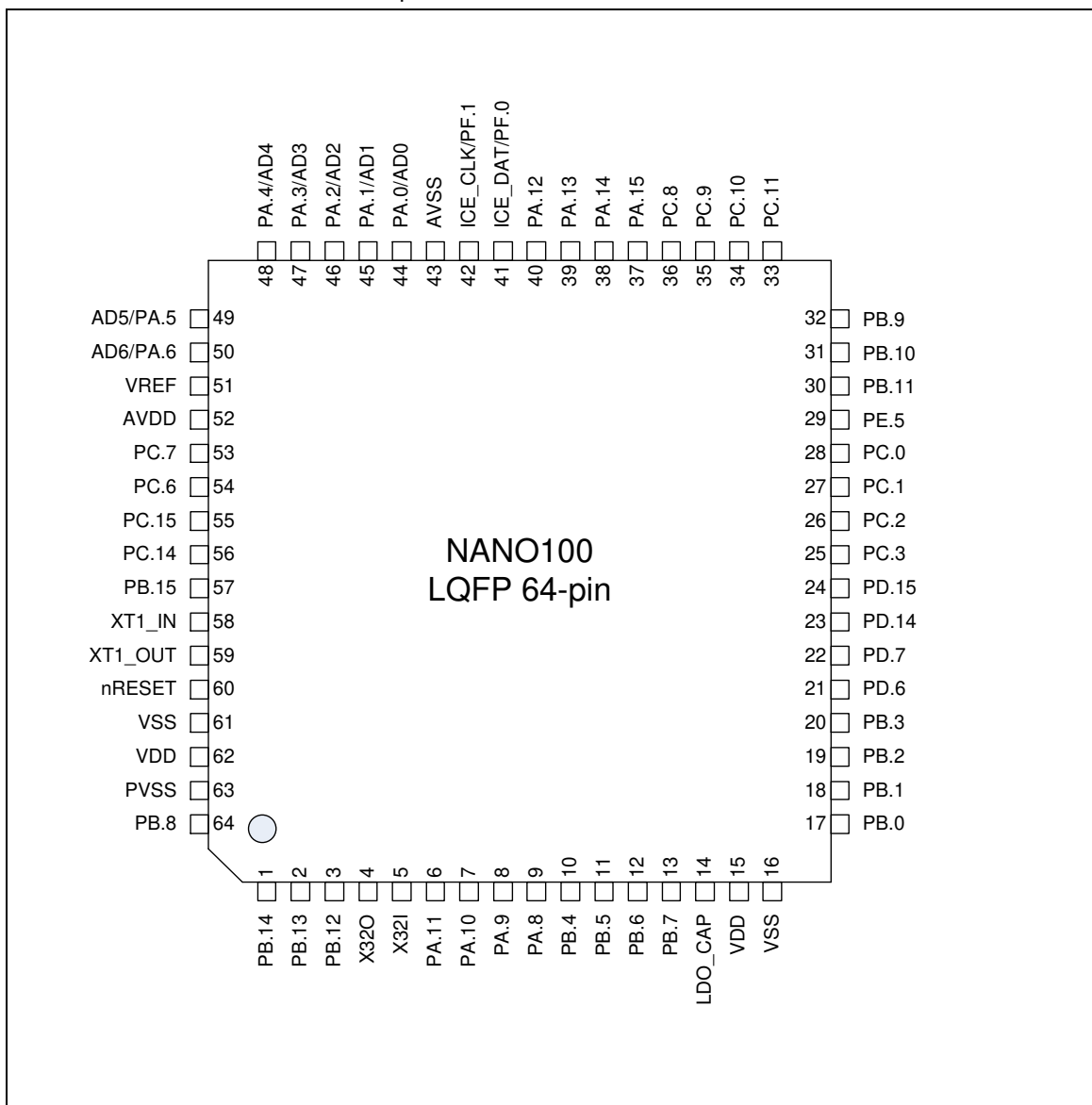

Figure 3-3 NuMicro® Nano100 LQFP 64-pin Diagram

3.3.1.3 NuMicro® Nano100 LQFP/QFN 48-pin

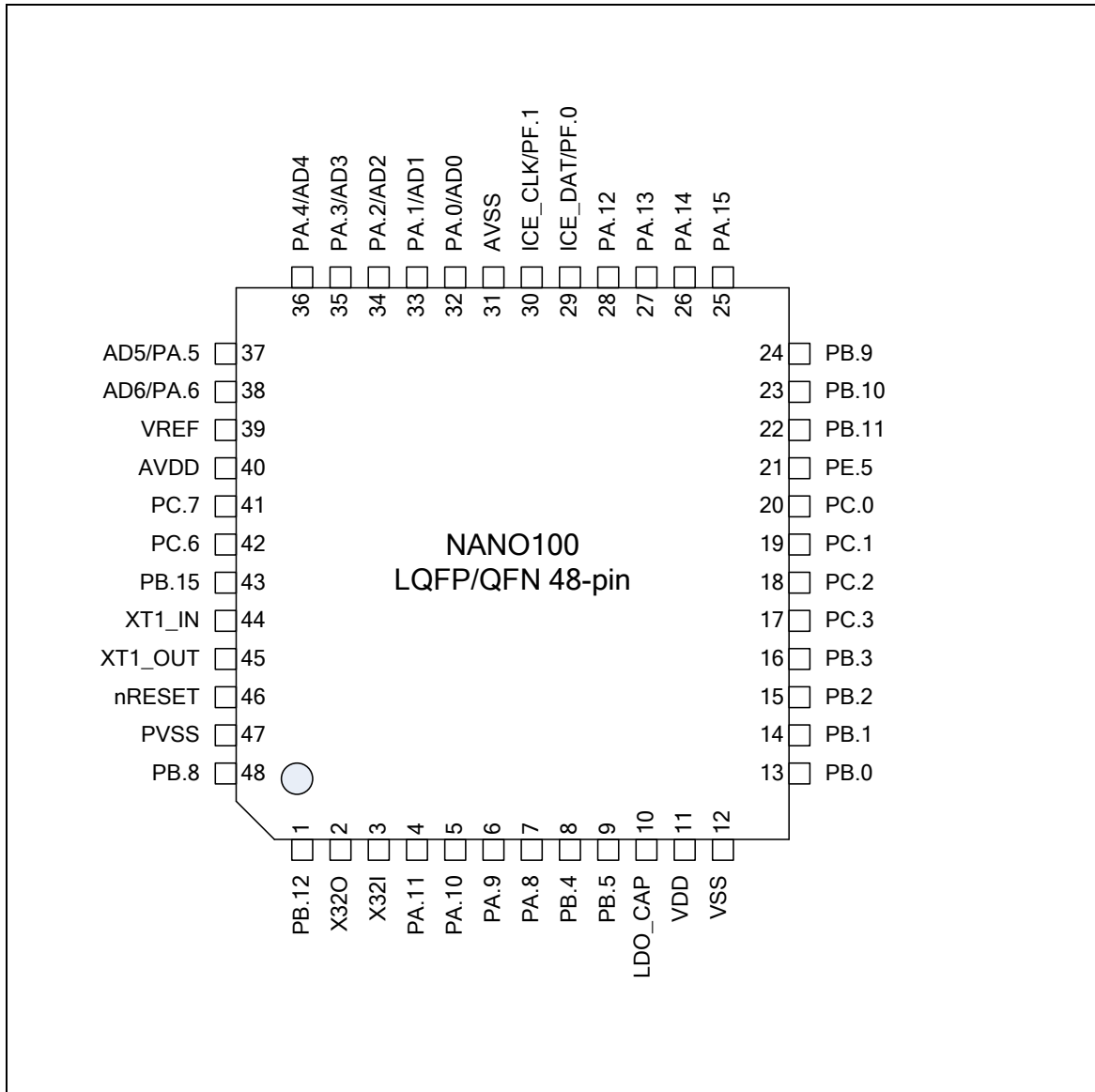

Figure 3-4 NuMicro® Nano100 LQFP 48-pin Diagram

3.3.2 NuMicro® Nano110 Pin Diagrams

3.3.2.1 NuMicro® Nano110 LQFP 128-pin

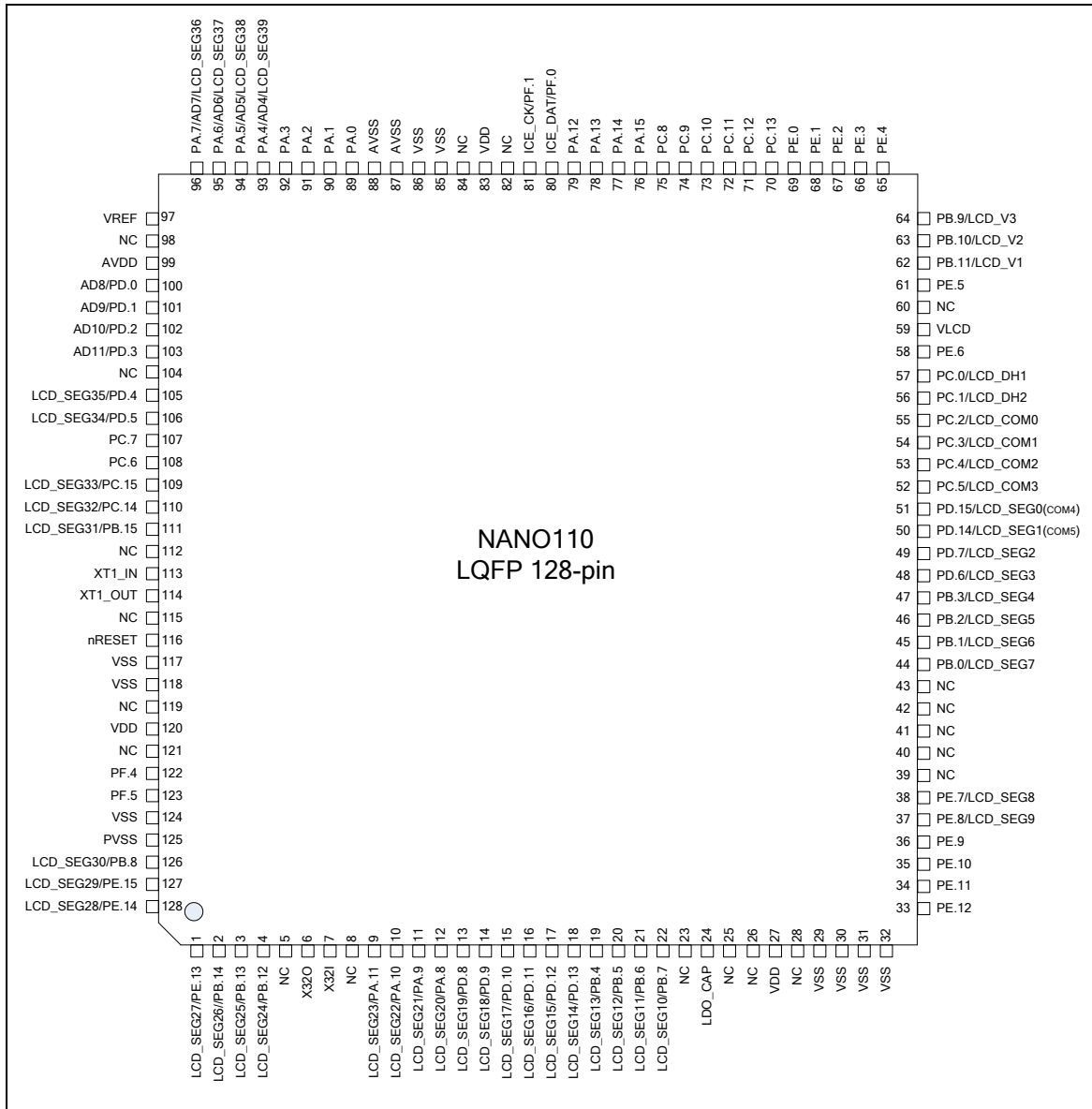

Figure 3-5 NuMicro® Nano110 LQFP 128-pin Diagram



3.3.2.2 NuMicro® Nano110 LQFP 64-pin

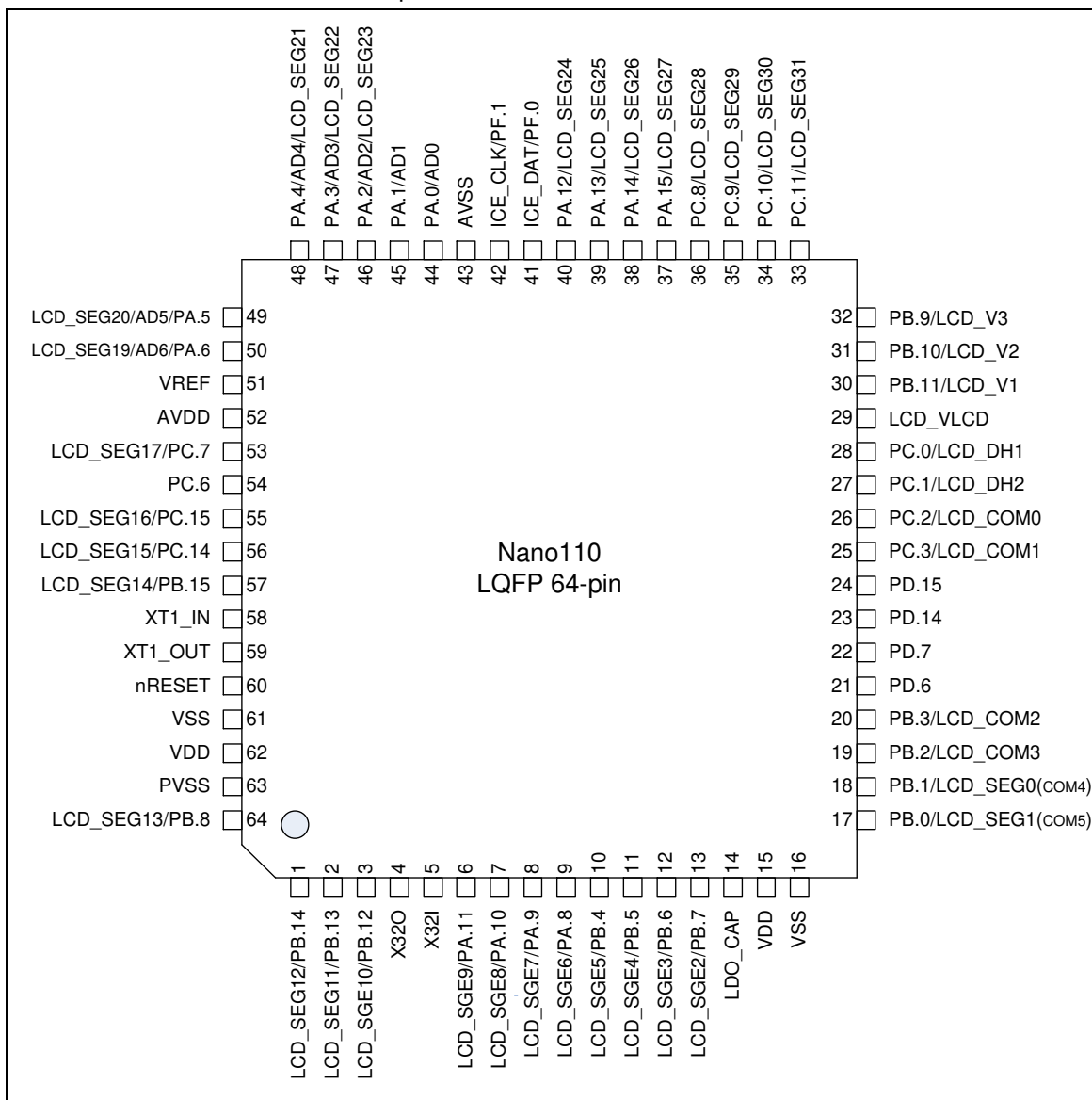

Figure 3-6 NuMicro® Nano110 LQFP 64-pin Diagram

3.3.3 NuMicro® Nano120 Pin Diagrams

3.3.3.1 NuMicro® Nano120 LQFP 128-pin

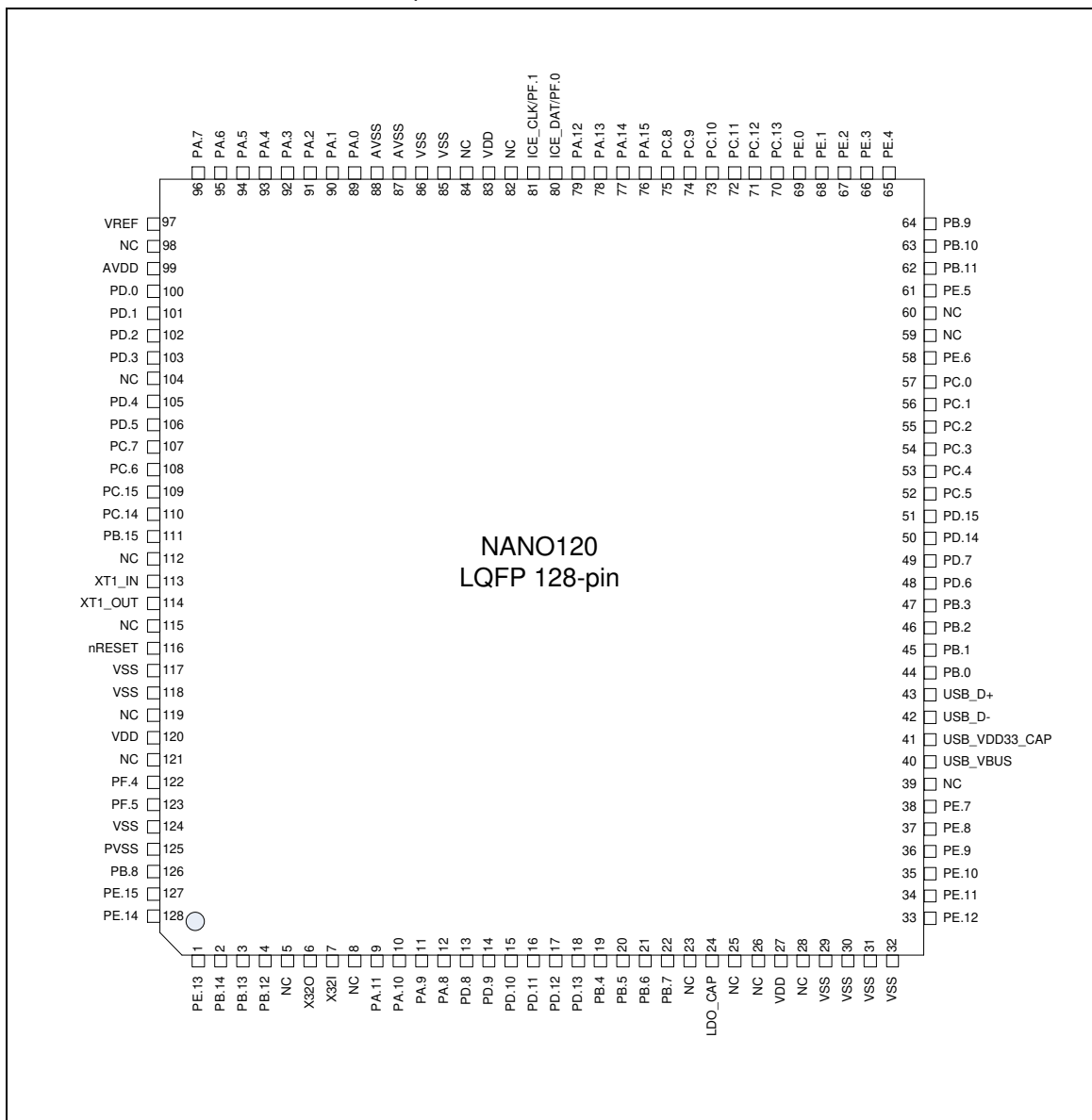

Figure 3-7 NuMicro® Nano120 LQFP 128-pin Diagram

3.3.3.2 NuMicro® Nano120 LQFP 64-pin

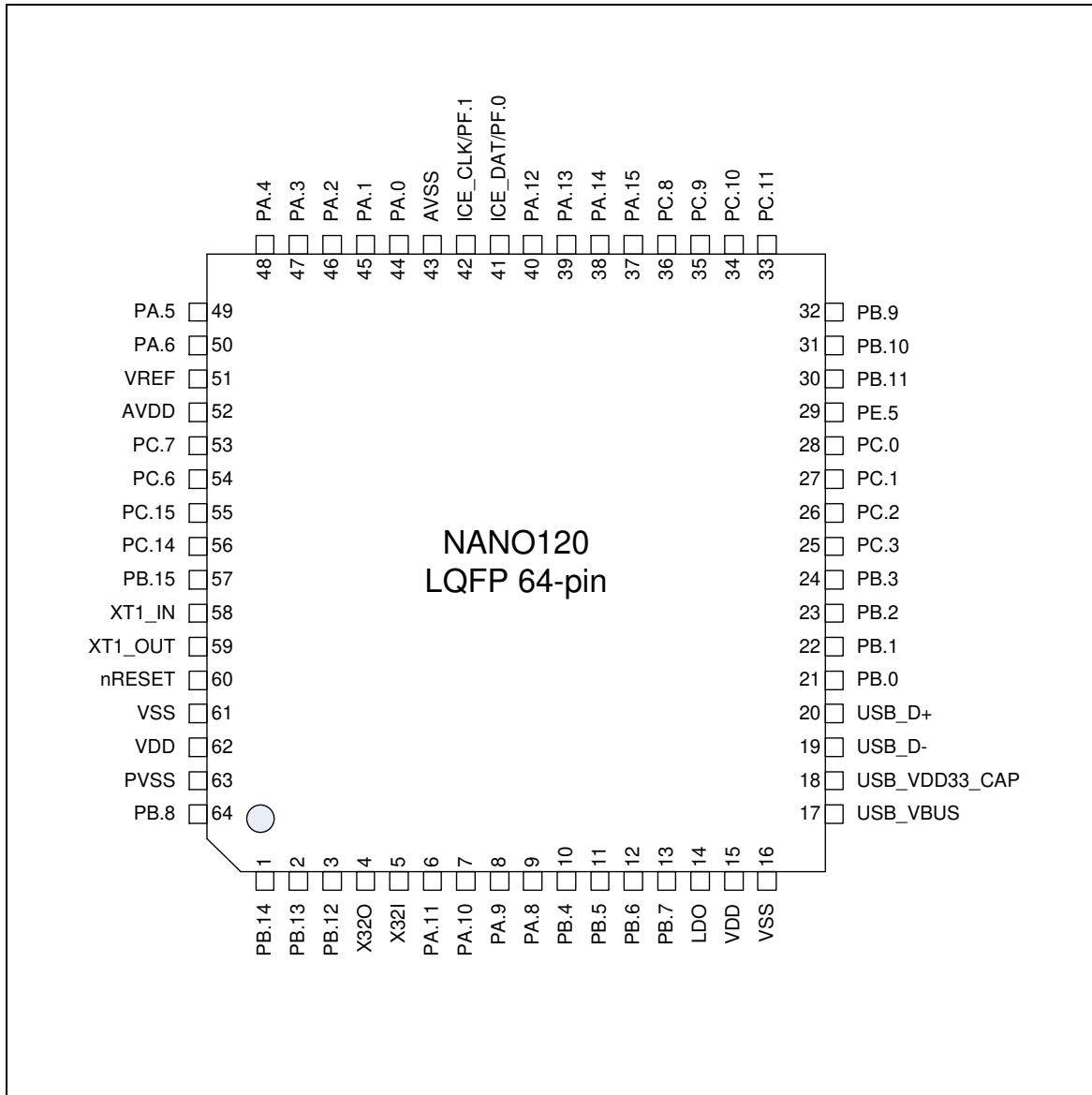

Figure 3-8 NuMicro® Nano120 LQFP 64-pin Diagram

3.3.3.3 NuMicro® Nano120 LQFP 48-pin

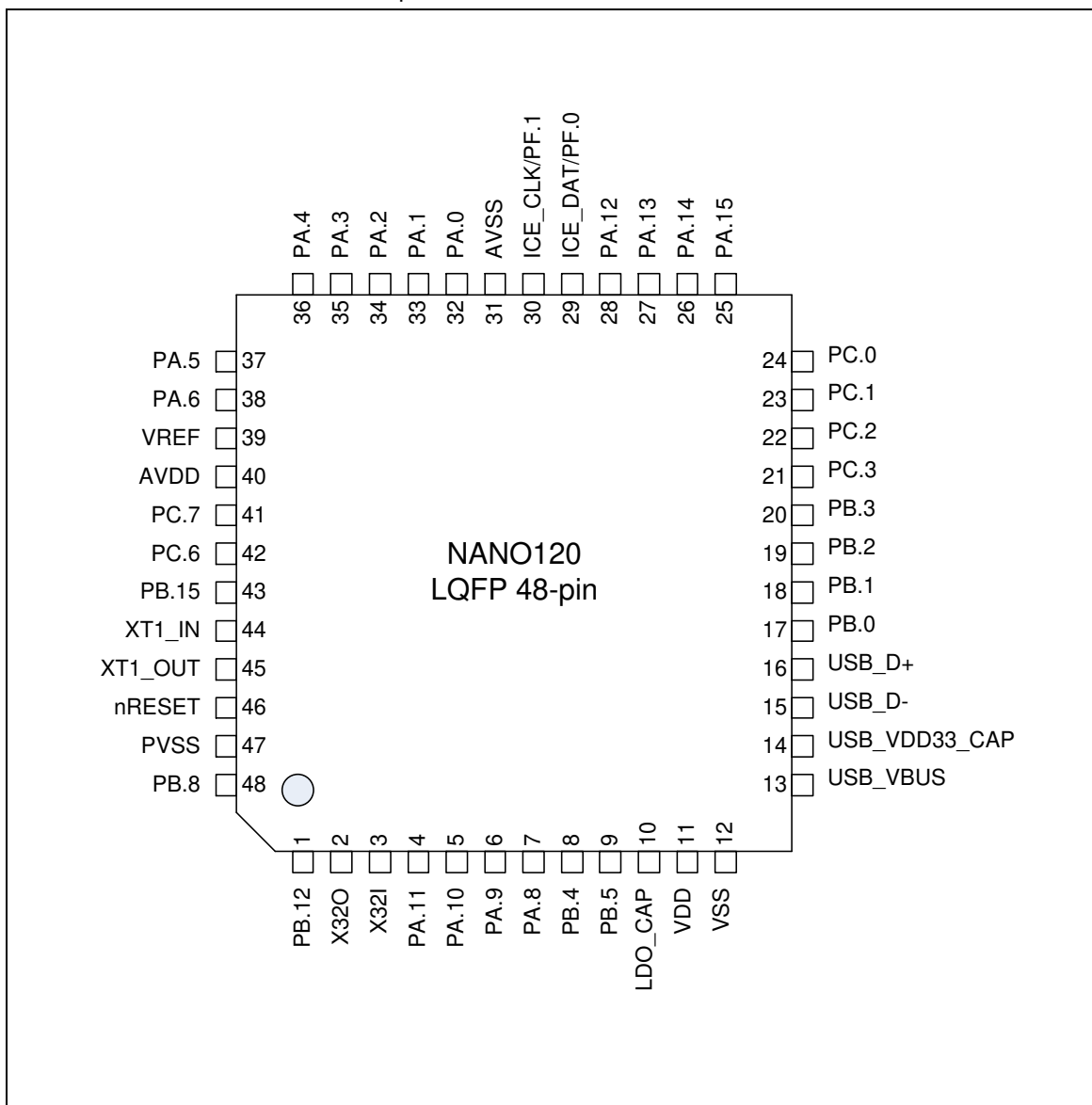
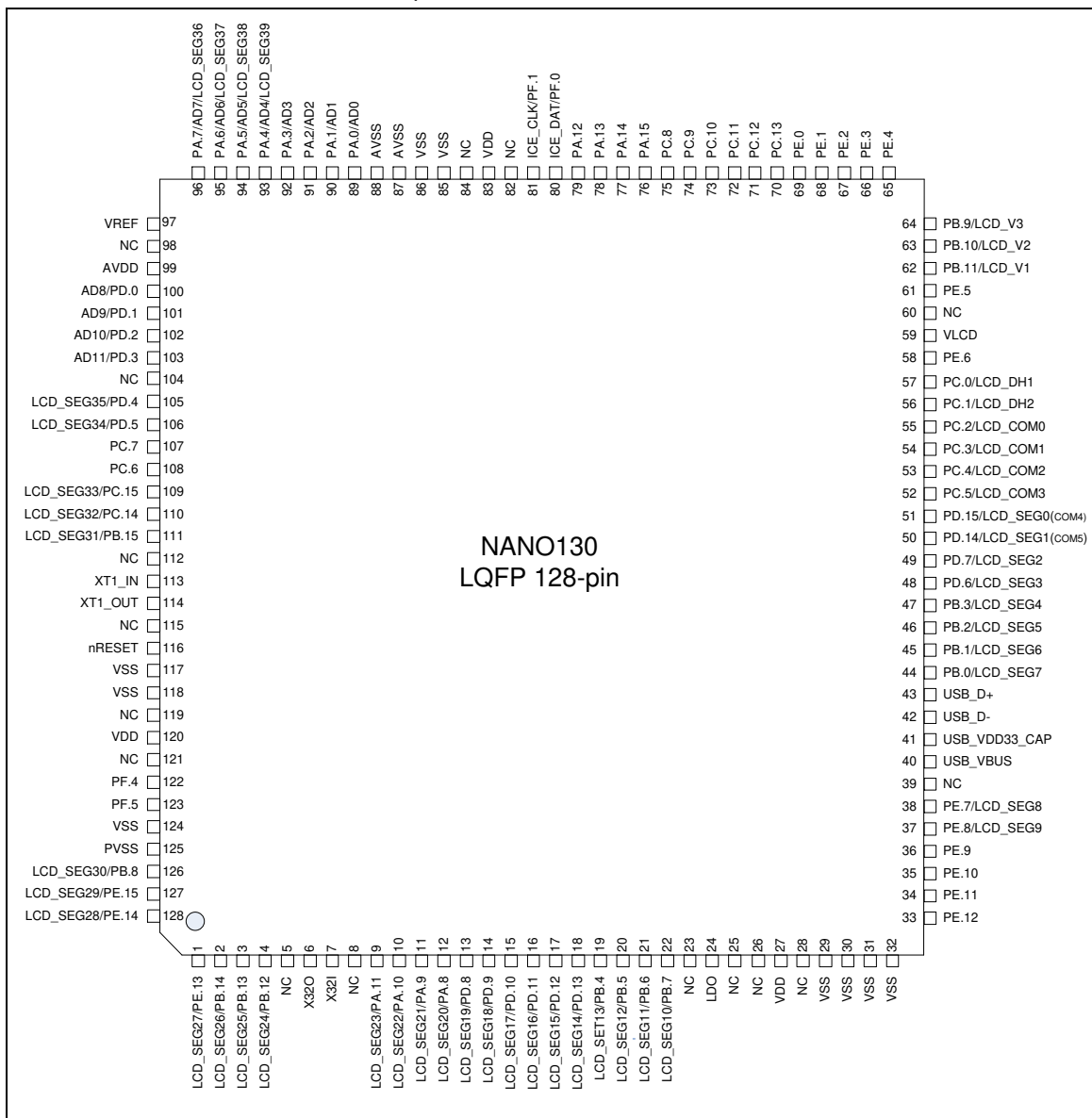

Figure 3-9 NuMicro® Nano120 LQFP 48-pin Diagram

3.3.4 NuMicro® Nano130 Pin Diagrams

3.3.4.1 NuMicro® Nano130 LQFP 128-pin



3.3.4.2 NuMicro® Nano130 LQFP 64-pin

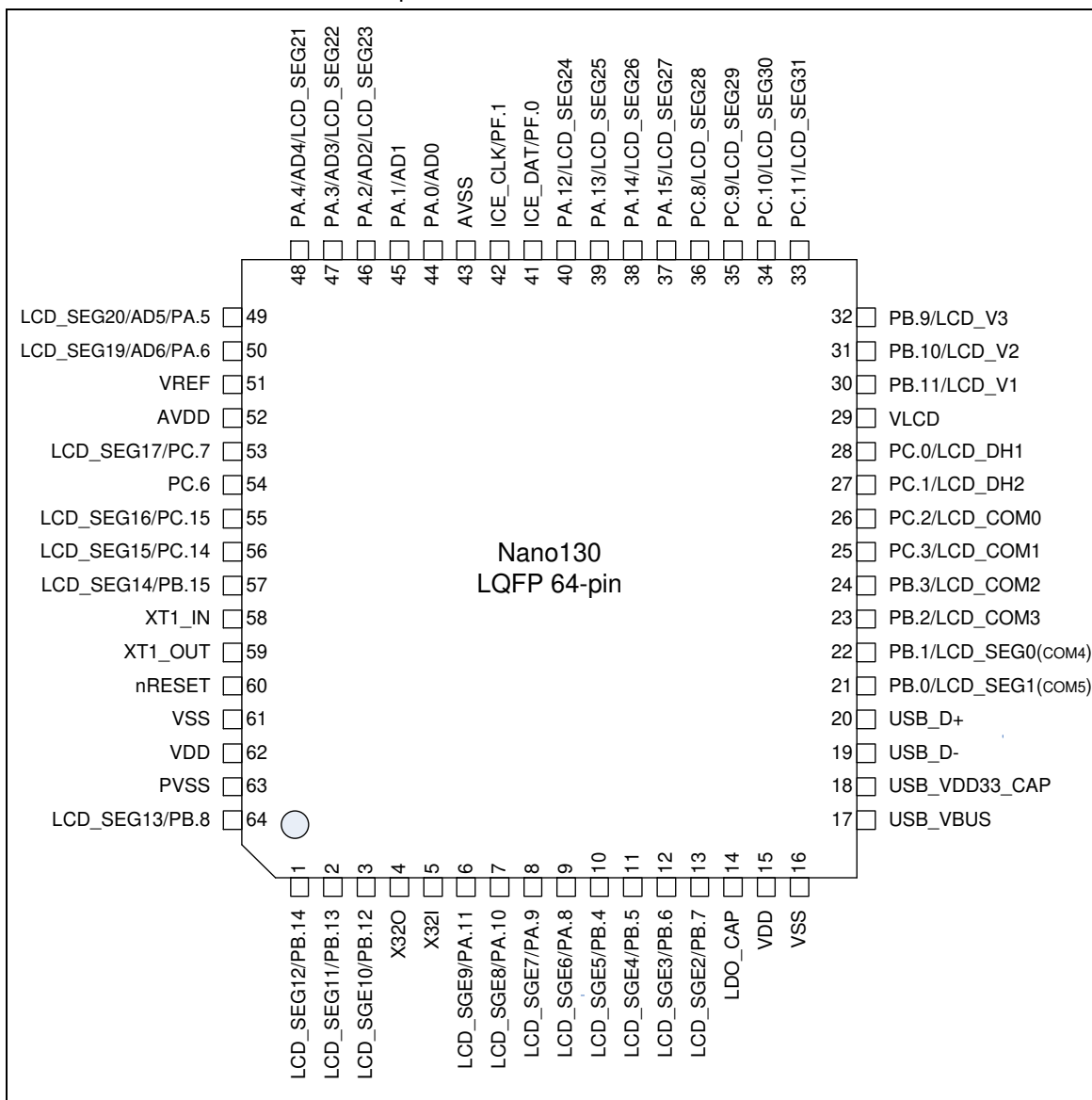

Figure 3-11 NuMicro® Nano130 LQFP 64-pin Diagram

### 3.4 Pin Description

#### 3.4.1 NuMicro® Nano100 Pin Description

Pin No.			Pin Name	Pin Type	Description
LQFP 128-pin	LQFP 64-pin	LQFP/QFN 48-pin			
1			PE.13	I/O	General purpose digital I/O pin
2	1		PB.14	I/O	General purpose digital I/O pin
			INT0	I	External interrupt0 input pin
			SC2_CD	I	SmartCard2 card detect pin
			SPI2_SS1	I/O	SPI2 2 <sup>nd</sup> slave select pin
3	2		PB.13	I/O	General purpose digital I/O pin
			EBI_AD1	I/O	EBI Address/Data bus bit1
4	3	1	PB.12	I/O	General purpose digital I/O pin
			EBI_AD0	I/O	EBI Address/Data bus bit0
			FCLKO	O	Frequency Divider output pin
5					NC
6	4	2	X32O	O	External 32.768 kHz crystal output pin
7	5	3	X32I	I	External 32.768 kHz crystal input pin
8					NC
9	6	4	PA.11	I/O	General purpose digital I/O pin
			I2C1_SCL	I/O	I <sup>2</sup> C1 clock pin
			EBI_nRD	O	EBI read enable output pin
			SC0_RST	O	SmartCard0 RST pin
			SPI2_MOSI0	I/O	SPI2 1 <sup>st</sup> MOSI (Master Out, Slave In) pin
10	7	5	PA.10	I/O	General purpose digital I/O pin
			I2C1_SDA	I/O	I <sup>2</sup> C1 data I/O pin
			EBI_nWR	O	EBI write enable output pin
			SC0_PWR	O	SmartCard0 Power pin
			SPI2_MISO0	I/O	SPI2 1 <sup>st</sup> MISO (Master In, Slave Out) pin
11	8	6	PA.9	I/O	General purpose digital I/O pin
			I2C0_SCL	I/O	I <sup>2</sup> C0 clock pin
			SC0_DAT	I/O	SmartCard0 DATA pin(SC0_UART_RXD)
			SPI2_CLK	I/O	SPI2 serial clock pin

Pin No.			Pin Name	Pin Type	Description
LQFP 128-pin	LQFP 64-pin	LQFP/QFN 48-pin			
12	9	7	PA.8	I/O	General purpose digital I/O pin
			I2C0_SDA	I/O	I <sup>2</sup> C0 data I/O pin
			SC0_CLK	O	SmartCard0 clock pin(SC0_UART_TXD)
			SPI2_SS0	I/O	SPI2 1 <sup>st</sup> slave select pin
13			PD.8	I/O	General purpose digital I/O pin
14			PD.9	I/O	General purpose digital I/O pin
15			PD.10	I/O	General purpose digital I/O pin
16			PD.11	I/O	General purpose digital I/O pin
17			PD.12	I/O	General purpose digital I/O pin
18			PD.13	I/O	General purpose digital I/O pin
19	10	8	PB.4	I/O	General purpose digital I/O pin
			UART1_RXD	I	UART1 Data receiver input pin
			SC0_CD	I	SmartCard0 card detect pin
			SPI2_SS0	I/O	SPI2 1 <sup>st</sup> slave select pin
20	11	9	PB.5	I/O	General purpose digital I/O pin
			UART1_TXD	O	UART1 Data transmitter output pin
			SC0_RST	O	SmartCard0 RST pin
			SPI2_CLK	I/O	SPI2 serial clock pin
21	12		PB.6	I/O	General purpose digital I/O pin
			UART1_RTSn	O	UART1 Request to Send output pin
			EBI_ALE	O	EBI address latch enable output pin
			SPI2_MISO0	I/O	SPI2 1 <sup>st</sup> MISO (Master In, Slave Out) pin
22	13		PB.7	I/O	General purpose digital I/O pin
			UART1_CTSn	I	UART1 Clear to Send input pin
			EBI_nCS	O	EBI chip select enable output pin
			SPI2_MOSI0	I/O	SPI2 1 <sup>st</sup> MOSI (Master Out, Slave In) pin
23					NC
24	14	10	LDO_CAP	P	LDO output pin
25					NC
26					NC



Pin No.			Pin Name	Pin Type	Description
LQFP 128-pin	LQFP 64-pin	LQFP/QFN 48-pin			
27	15	11	VDD	P	Power supply for I/O ports and LDO source
28					NC
29	16	12	VSS	P	Ground
30			VSS	P	Ground
31			VSS	P	Ground
32			VSS	P	Ground
33			PE.12	I/O	General purpose digital I/O pin
34			PE.11	I/O	General purpose digital I/O pin
35			PE.10	I/O	General purpose digital I/O pin
36			PE.9	I/O	General purpose digital I/O pin
37			PE.8	I/O	General purpose digital I/O pin
38			PE.7	I/O	General purpose digital I/O pin
39					NC
40					NC
41					NC
42					NC
43					NC
44	17	13	PB.0	I/O	General purpose digital I/O pin
			UART0_RXD	I	UART0 Data receiver input pin
			SPI1_MOSI0	I/O	SPI1 1 <sup>st</sup> MOSI (Master Out, Slave In) pin
45	18	14	PB.1	I/O	General purpose digital I/O pin
			UART0_TXD	O	UART0 Data transmitter output pin
			SPI1_MISO0	I/O	SPI1 1 <sup>st</sup> MISO (Master In, Slave Out) pin
46	19	15	PB.2	I/O	General purpose digital I/O pin
			UART0_RTSn	O	UART0 Request to Send output pin
			EBI_nWRL	O	EBI low byte write enable output pin
			SPI1_CLK	I/O	SPI1 serial clock pin
47	20	16	PB.3	I/O	General purpose digital I/O pin
			UART0_CTSn	I	UART0 Clear to Send input pin
			EBI_nWRH	O	EBI high byte write enable output pin

Pin No.			Pin Name	Pin Type	Description
LQFP 128-pin	LQFP 64-pin	LQFP/QFN 48-pin			
			SPI1_SS0	I/O	SPI1 1 <sup>st</sup> slave select pin
48	21		PD.6	I/O	General purpose digital I/O pin
49	22		PD.7	I/O	General purpose digital I/O pin
50	23		PD.14	I/O	General purpose digital I/O pin
51	24		PD.15	I/O	General purpose digital I/O pin
52			PC.5	I/O	General purpose digital I/O pin
			SPI0_MOSI1	I/O	SPI0 2 <sup>nd</sup> MOSI (Master Out, Slave In) pin
53			PC.4	I/O	General purpose digital I/O pin
			SPI0_MISO1	I/O	SPI0 2 <sup>nd</sup> MISO (Master In, Slave Out) pin
54	25	17	PC.3	I/O	General purpose digital I/O pin
			SPI0_MOSI0	I/O	SPI0 1 <sup>st</sup> MOSI (Master Out, Slave In) pin
			I2S_DO	O	I <sup>2</sup> S data output
			SC1_RST	O	SmartCard1 RST pin
55	26	18	PC.2	I/O	General purpose digital I/O pin
			SPI0_MISO0	I/O	SPI0 1 <sup>st</sup> MISO (Master In, Slave Out) pin
			I2S_DI	I	I <sup>2</sup> S data input
			SC1_PWR	O	SmartCard1 PWR pin
56	27	19	PC.1	I/O	General purpose digital I/O pin
			SPI0_CLK	I/O	SPI0 serial clock pin
			I2S_BCLK	I/O	I <sup>2</sup> S bit clock pin
			SC1_DAT	I/O	SmartCard1 DATA pin(SC1_UART_RXD)
57	28	20	PC.0 / MCLKO	I/O	General purpose digital I/O pin / Module clock output pin
			SPI0_SS0	I/O	SPI0 1 <sup>st</sup> slave select pin
			I2S_LRCLK	I/O	I <sup>2</sup> S left right channel clock
			SC1_CLK	O	SmartCard1 clock pin(SC1_UART_TXD)
58			PE.6	I/O	General purpose digital I/O pin
59					NC
60					NC
61	29	21	PE.5	I/O	General purpose digital I/O pin
			PWM1_CH1	I/O	PWM1 Channel1 output

Pin No.			Pin Name	Pin Type	Description
LQFP 128-pin	LQFP 64-pin	LQFP/QFN 48-pin			
62	30	22	PB.11	I/O	General purpose digital I/O pin
			PWM1_CH0	I/O	PWM1 Channel0 output
			TM3	O	Timer3 external counter input
			SC2_DAT	I/O	SmartCard2 DATA pin(SC2_UART_RXD)
			SPI0_MISO0	I/O	SPI0 1 <sup>st</sup> MISO (Master In, Slave Out) pin
63	31	23	PB.10	I/O	General purpose digital I/O pin
			SPI0_SS1	I/O	SPI0 2 <sup>nd</sup> slave select pin
			TM2	O	Timer2 external counter input
			SC2_CLK	O	SmartCard2 clock pin(SC2_UART_TXD)
			SPI0_MOSI0	I/O	SPI0 1 <sup>st</sup> MOSI (Master Out, Slave In) pin
64	32	24	PB.9	I/O	General purpose digital I/O pin
			SPI1_SS1	I/O	SPI1 2 <sup>nd</sup> slave select pin
			TM1	O	Timer1 external counter input
			SC2_RST	O	SmartCard2 RST pin
			INT0	I	External interrupt0 input pin
65			PE.4	I/O	General purpose digital I/O pin
			SPI0_MOSI0	I/O	SPI0 1 <sup>st</sup> MOSI (Master Out, Slave In) pin
66			PE.3	I/O	General purpose digital I/O pin
			SPI0_MISO0	I/O	SPI0 1 <sup>st</sup> MISO (Master In, Slave Out) pin
67			PE.2	I/O	General purpose digital I/O pin
			SPI0_CLK	I/O	SPI0 serial clock pin
68			PE.1	I/O	General purpose digital I/O pin.
			PWM1_CH3	I/O	PWM1 Channel3 output
			SPI0_SS0	I/O	SPI0 1 <sup>st</sup> slave select pin
69			PE.0	I/O	General purpose digital I/O pin
			PWM1_CH2	I/O	PWM1 Channel2 output
			I2S_MCLK	O	I <sup>2</sup> S master clock output pin
70			PC.13	I/O	General purpose digital I/O pin
			SPI1_MOSI1	I/O	SPI1 2 <sup>nd</sup> MOSI (Master Out, Slave In) pin
			PWM1_CH1	O	PWM1 Channel1 output

Pin No.			Pin Name	Pin Type	Description
LQFP 128-pin	LQFP 64-pin	LQFP/QFN 48-pin			
			SNOOPER	I	Snooper pin
			INT1	I	External interrupt 1
			I2C0_SCL	O	I <sup>2</sup> C0 clock pin
71			PC.12	I/O	General purpose digital I/O pin
			SPI1_MISO1	I/O	SPI1 2 <sup>nd</sup> MISO (Master In, Slave Out) pin
			PWM1_CH0	O	PWM1 Channel0 output
			INT0	I	External interrupt0 input pin
			I2C0_SDA	I/O	I <sup>2</sup> C0 data I/O pin
72	33		PC.11	I/O	General purpose digital I/O pin
			SPI1_MOSI0	I/O	SPI1 1 <sup>st</sup> MOSI (Master Out, Slave In) pin
			UART1_TXD	O	UART1 Data transmitter output pin
73	34		PC.10	I/O	General purpose digital I/O pin
			SPI1_MISO0	I/O	SPI1 1 <sup>st</sup> MISO (Master In, Slave Out) pin
			UART1_RXD	I	UART1 Data receiver input pin
74	35		PC.9	I/O	General purpose digital I/O pin
			SPI1_CLK	I/O	SPI1 serial clock pin
			I2C1_SCL	I/O	I <sup>2</sup> C1 clock pin
75	36		PC.8	I/O	General purpose digital I/O pin
			SPI1_SS0	I/O	SPI1 1 <sup>st</sup> slave select pin
			EBI_MCLK	O	EBI external clock output pin
			I2C1_SDA	I/O	I <sup>2</sup> C1 data I/O pin
76	37	25	PA.15	I/O	General purpose digital I/O pin
			PWM0_CH3	I/O	PWM0 Channel3 output
			I2S_MCLK	O	I <sup>2</sup> S master clock output pin
			TC3	I	Timer3 capture input
			SC0_PWR	O	SmartCard0 Power pin
			UART0_TXD	O	UART0 Data transmitter output pin
77	38	26	PA.14	I/O	General purpose digital I/O pin
			PWM0_CH2	I/O	PWM0 Channel2 output
			EBI_AD15	I/O	EBI Address/Data bus bit15

NANO100 SERIES DATASHEET

Pin No.			Pin Name	Pin Type	Description
LQFP 128-pin	LQFP 64-pin	LQFP/QFN 48-pin			
			TC2	I	Timer2 capture input
			UART0_RXD	I	UART0 Data receiver input pin
78	39	27	PA.13	I/O	General purpose digital I/O pin
			PWM0_CH1	I/O	PWM0 Channel1 output
			EBI_AD14	I/O	EBI Address/Data bus bit14
			TC1	I	Timer1 capture input
			I2C0_SCL	I/O	I <sup>2</sup> C0 clock pin
79	40	28	PA.12	I/O	General purpose digital I/O pin
			PWM0_CH0	I/O	PWM0 Channel0 output
			EBI_AD13	I/O	EBI Address/Data bus bit13
			TC0	I	Timer0 capture input
			I2C0_SDA	I/O	I <sup>2</sup> C0 data I/O pin
80	41	29	ICE_DAT	I/O	Serial Wired Debugger Data pin
			PF.0	I/O	General purpose digital I/O pin
			INT0	I	External interrupt0 input pin
81	42	30	ICE_CLK	I	Serial Wired Debugger Clock pin
			PF.1	I/O	General purpose digital I/O pin
			FCLKO	O	Frequency Divider output pin
			INT1	I	External interrupt1 input pin
82					NC
83			VDD	P	Power supply for I/O ports and LDO source for internal PLL and digital circuit
84					NC
85			VSS	P	Ground
86			VSS	P	Ground
87	43	31	AVSS	AP	Ground Pin for analog circuit
88			AVSS	AP	Ground Pin for analog circuit
89	44	32	PA.0	I/O	General purpose digital I/O pin
			AD0	AI	ADC analog input0
			SC2_CD	I	SmartCard2 card detect
90	45	33	PA.1	I/O	General purpose digital I/O pin

Pin No.			Pin Name	Pin Type	Description
LQFP 128-pin	LQFP 64-pin	LQFP/QFN 48-pin			
			AD1	AI	ADC analog input1
			EBI_AD12	I/O	EBI Address/Data bus bit12
91	46	34	PA.2	I/O	General purpose digital I/O pin
			AD2	AI	ADC analog input2
			EBI_AD11	I/O	EBI Address/Data bus bit11
			UART1_RXD	I	UART1 Data receiver input pin
92	47	35	PA.3	I/O	General purpose digital I/O pin
			AD3	AI	ADC analog input3
			EBI_AD10	I/O	EBI Address/Data bus bit10
			UART1_TXD	O	UART1 Data transmitter output pin
93	48	36	PA.4	I/O	General purpose digital I/O pin
			AD4	AI	ADC analog input4
			EBI_AD9	I/O	EBI Address/Data bus bit9
			SC2_PWR	O	SmartCard2 Power pin
			I2C0_SDA	I/O	I <sup>2</sup> C0 data I/O pin
94	49	37	PA.5	I/O	General purpose digital I/O pin
			AD5	AI	ADC analog input5
			EBI_AD8	I/O	EBI Address/Data bus bit8
			SC2_RST	O	SmartCard2 RST pin
			I2C0_SCL	I/O	I <sup>2</sup> C0 clock pin
95	50	38	PA.6	I/O	General purpose digital I/O pin
			AD6	AI	ADC analog input6
			EBI_AD7	I/O	EBI Address/Data bus bit7
			TC3	I	Timer3 capture input
			SC2_CLK	O	SmartCard2 clock pin(SC2_UART_TXD)
			PWM0_CH3	O	PWM0 Channel3 output
96			PA.7	I/O	General purpose digital I/O pin
			AD7	AI	ADC analog input7
			EBI_AD6	I/O	EBI Address/Data bus bit6
			TC2	I	Timer2 capture input

Pin No.			Pin Name	Pin Type	Description
LQFP 128-pin	LQFP 64-pin	LQFP/QFN 48-pin			
			SC2_DAT	I/O	SmartCard2 DATA pin(SC2_UART_RXD)
			PWM0_CH2	O	PWM0 Channel2 output
97	51	39	VREF	AP	Voltage reference input for ADC
98					NC
99	52	40	AVDD	AP	Power supply for internal analog circuit
100			PD.0	I/O	General purpose digital I/O pin
			UART1_RXD	I	UART1 Data receiver input pin
			SPI2_SS0	I/O	SPI2 1 <sup>st</sup> slave select pin
			SC1_CLK	O	SmartCard1 clock pin(SC1_UART_TXD)
			AD8	AI	ADC analog input8
101			PD.1	I/O	General purpose digital I/O pin
			UART1_TXD	O	UART1 Data transmitter output pin
			SPI2_CLK	I/O	SPI2 serial clock pin
			SC1_DAT	I/O	SmartCard1 DATA pin(SC1_UART_RXD).
			AD9	AI	ADC analog input9
102			PD.2	I/O	General purpose digital I/O pin
			UART1_RTSn	O	UART1 Request to Send output pin
			I2S_LRCLK	I/O	I <sup>2</sup> S left right channel clock
			SPI2_MISO0	I/O	SPI2 1 <sup>st</sup> MISO (Master In, Slave Out) pin
			SC1_PWR	O	SmartCard1 Power pin
			AD10	AI	ADC analog input10
103			PD.3	I/O	General purpose digital I/O pin
			UART1_CTSn	I	UART1 Clear to Send input pin
			I2S_BCLK	I/O	I <sup>2</sup> S bit clock pin
			SPI2_MOSI0	I/O	SPI2 1 <sup>st</sup> MOSI (Master Out, Slave In) pin
			SC1_RST	O	SmartCard1 RST pin
			AD11	AI	ADC analog input11
104					NC
105			PD.4	I/O	General purpose digital I/O pin
			I2S_DI	I	I <sup>2</sup> S data input

Pin No.			Pin Name	Pin Type	Description
LQFP 128-pin	LQFP 64-pin	LQFP/QFN 48-pin			
			SPI2_MISO1	I/O	SPI2 2 <sup>nd</sup> MISO (Master In, Slave Out) pin
			SC1_CD	I	SmartCard1 card detect
106			PD.5	I/O	General purpose digital I/O pin
			I2S_DO	O	I <sup>2</sup> S data output
			SPI2_MOSI1	I/O	SPI2 2 <sup>nd</sup> MOSI (Master Out, Slave In) pin
107	53	41	PC.7	I/O	General purpose digital I/O pin
			DA1_OUT	AO	DAC 1 output
			EBI_AD5	I/O	EBI Address/Data bus bit5
			TC1	I	Timer1 capture input
			PWM0_CH1	O	PWM1 Channel1 output
108	54	42	PC.6	I/O	General purpose digital I/O pin
			DA0_OUT	I	DAC0 output
			EBI_AD4	I/O	EBI Address/Data bus bit4
			TC0	I	Timer0 capture input
			SC1_CD	I	SmartCard1 card detect pin
			PWM0_CH0	O	PWM0 Channel0 output
109	55		PC.15	I/O	General purpose digital I/O pin
			EBI_AD3	I/O	EBI Address/Data bus bit3
			TC0	I	Timer0 capture input
			PWM1_CH2	O	PWM1 Channel1 output
110	56		PC.14	I/O	General purpose digital I/O pin
			EBI_AD2	I/O	EBI Address/Data bus bit2
			PWM1_CH3	I/O	PWM1 Channel3 output
111	57	43	PB.15	I/O	General purpose digital I/O pin
			INT1	I	External interrupt1 input pin
			SNOOPER	I	Snooper pin
			SC1_CD	I	SmartCard1 card detect
112					NC
113	58	44	XT1_IN	O	External 4~24 MHz crystal output pin
			PF.3	I/O	General purpose digital I/O pin



Pin No.			Pin Name	Pin Type	Description
LQFP 128-pin	LQFP 64-pin	LQFP/QFN 48-pin			
114	59	45	XT1_OUT	I	External 4~24 MHz crystal input pin
			PF.2	I/O	General purpose digital I/O pin
115					NC
116	60	46	nRESET	I	External reset input: Low active, set this pin low reset chip to initial state. With internal pull-up.
117	61		VSS	P	Ground
118			VSS	P	Ground
119					NC
120	62		VDD	P	Power supply for I/O ports and LDO source for internal PLL and digital circuit
121					NC
122			PF.4	I/O	General purpose digital I/O pin
			I2C0_SDA	I/O	I <sup>2</sup> C0 data I/O pin
123			PF.5	I/O	General purpose digital I/O pin
			I2C0_SCL	I/O	I <sup>2</sup> C0 clock pin
124			VSS	P	Ground
125	63	47	PVSS	P	PLL Ground
126	64	48	PB.8	I/O	General purpose digital I/O pin
			STADC	I	ADC external trigger input.
			TM0	I	Timer0 external counter input
			INT0	I	External interrupt0 input pin
			SC2_PWR	O	SmartCard2 Power pin
127			PE.15	I/O	General purpose digital I/O pin
128			PE.14	I/O	General purpose digital I/O pin

**Note:**

Pin Type: I = Digital Input, O = Digital Output; AI = Analog Input; AO = Analog Output; P = Power Pin; AP = Analog Power.

3.4.2 NuMicro® Nano110 Pin Description

Pin No.			Pin Name	Pin Type	Description
LQFP 128-pin	LQFP 64-pin	LQFP 48-pin			
1			PE.13	I/O	General purpose digital I/O pin
			LCD_SEG27	O	LCD segment output 27 at LQFP128
2	1		PB.14	I/O	General purpose digital I/O pin
			INT0	I	External interrupt0 input pin
			SC2_CD	I	SmartCard2 card detect
			SPI2_SS1	I/O	SPI2 2 <sup>nd</sup> slave select pin
			LCD_SEG12	O	LCD segment output 12 at LQFP64
			LCD_SEG26	O	LCD segment output 26 at LQFP128
3	2		PB.13	I/O	General purpose digital I/O pin
			EBI_AD1	I/O	EBI Address/Data bus bit1
			LCD_SEG11	O	LCD segment output 11 at LQFP64
			LCD_SEG25	O	LCD segment output 25 at LQFP128
4	3		PB.12	I/O	General purpose digital I/O pin
			EBI_AD0	I/O	EBI Address/Data bus bit0
			FCLKO	O	Frequency Divider output pin
			LCD_SEG10	O	LCD segment output 10 at LQFP64
			LCD_SEG24	O	LCD segment output 24 at LQFP128
5					NC
6	4		X32O	O	External 32.768 kHz crystal output pin
7	5		X32I	I	External 32.768 kHz crystal input pin
8					NC
9	6		PA.11	I/O	General purpose digital I/O pin
			I2C1_SCL	I/O	I <sup>2</sup> C1 clock pin
			EBI_nRD	O	EBI read enable output pin
			SC0_RST	O	SmartCard0 RST pin
			SPI2_MOSI0	I/O	SPI2 1 <sup>st</sup> MOSI (Master Out, Slave In) pin
			LCD_SEG9	O	LCD segment output 9 at LQFP64
			LCD_SEG23	O	LCD segment output 23 at LQFP128
10	7		PA.10	I/O	General purpose digital I/O pin
			I2C1_SDA	I/O	I <sup>2</sup> C1 data I/O pin

Pin No.			Pin Name	Pin Type	Description
LQFP 128-pin	LQFP 64-pin	LQFP 48-pin			
			EBI_nWR	O	EBI write enable output pin
			SC0_PWR	O	SmartCard0 Power pin
			SPI2_MISO0	I/O	SPI2 1 <sup>st</sup> MISO (Master In, Slave Out) pin
			LCD_SEG8	O	LCD segment output 8 at LQFP64
			LCD_SEG22	O	LCD segment output 22 at LQFP128
11	8		PA.9	I/O	General purpose digital I/O pin
			I2C0_SCL	I/O	I <sup>2</sup> C0 clock pin
			SC0_DAT	I/O	SmartCard0 DATA pin(SC0_UART_RXD)
			SPI2_CLK	I/O	SPI2 serial clock pin
			LCD_SEG7	O	LCD segment output 7 at LQFP64
			LCD_SEG21	O	LCD segment output 21 at LQFP128
12	9		PA.8	I/O	General purpose digital I/O pin
			I2C0_SDA	I/O	I <sup>2</sup> C0 data I/O pin
			SC0_CLK	O	SmartCard0 clock pin(SC0_UART_TXD)
			SPI2_SS0	I/O	SPI2 1 <sup>st</sup> slave select pin
			LCD_SEG6	O	LCD segment output 6 at LQFP64
			LCD_SEG20	O	LCD segment output 20 at LQFP128
13			PD.8	I/O	General purpose digital I/O pin
			LCD_SEG19	O	LCD segment output 19 at LQFP128
14			PD.9	I/O	General purpose digital I/O pin
			LCD_SEG18	O	LCD segment output 18 at LQFP128
15			PD.10	I/O	General purpose digital I/O pin
			LCD_SEG17	O	LCD segment output 17 at LQFP128
16			PD.11	I/O	General purpose digital I/O pin
			LCD_SEG16	O	LCD segment output 16 at LQFP128
17			PD.12	I/O	General purpose digital I/O pin
			LCD_SEG15	O	LCD segment output 15 at LQFP128
18			PD.13	I/O	General purpose digital I/O pin
			LCD_SEG14	O	LCD segment output 14 at LQFP128
19	10		PB.4	I/O	General purpose digital I/O pin

Pin No.			Pin Name	Pin Type	Description
LQFP 128-pin	LQFP 64-pin	LQFP 48-pin			
			UART1_RXD	I	UART1 Data receiver input pin
			SC0_CD	I	SmartCard0 card detect pin
			SPI2_SS0	I/O	SPI2 1 <sup>st</sup> slave select pin
			LCD_SEG5	O	LCD segment output 5 at LQFP64
			LCD_SEG13	O	LCD segment output 13 at LQFP128
20	11		PB.5	I/O	General purpose digital I/O pin
			UART1_TXD	O	UART1 Data transmitter output pin
			SC0_RST	O	SmartCard0 RST pin
			SPI2_CLK	I/O	SPI2 serial clock pin
			LCD_SEG4	O	LCD segment output 4 at LQFP64
			LCD_SEG12	O	LCD segment output 12 at LQFP128
21	12		PB.6	I/O	General purpose digital I/O pin
			UART1_RTSn	O	UART1 Request to Send output pin
			EBI_ALE	O	EBI address latch enable output pin
			SPI2_MISO0	I/O	SPI2 1 <sup>st</sup> MISO (Master In, Slave Out) pin
			LCD_SEG3	O	LCD segment output 3 at LQFP64
			LCD_SEG11	O	LCD segment output 11 at LQFP128
22	13		PB.7	I/O	General purpose digital I/O pin
			UART1_CTSn	I	UART1 Clear to Send input pin
			EBI_nCS	O	EBI chip select enable output pin
			SPI2_MOSI0	I/O	SPI2 1 <sup>st</sup> MOSI (Master Out, Slave In) pin
			LCD_SEG2	O	LCD segment output 2 at LQFP64
			LCD_SEG10	O	LCD segment output 10 at LQFP128
23					NC
24	14		LDO_CAP	P	LDO output pin
25					NC
26					NC
27	15		VDD	P	Power supply for I/O ports and LDO source
28					NC
29	16		VSS	P	Ground

Pin No.			Pin Name	Pin Type	Description
LQFP 128-pin	LQFP 64-pin	LQFP 48-pin			
30			VSS	<b>P</b>	Ground
31			VSS	<b>P</b>	Ground
32			VSS	<b>P</b>	Ground
33			PE.12	<b>I/O</b>	General purpose digital I/O pin
			UART1_CTSn	<b>I</b>	UART1 Clear to Send input pin
34			PE.11	<b>I/O</b>	General purpose digital I/O pin
			UART1_RTSn	<b>O</b>	UART1 Request to Send output pin
35			PE.10	<b>I/O</b>	General purpose digital I/O pin
			UART1_TXD	<b>O</b>	UART1 Data transmitter output pin
36			PE.9	<b>I/O</b>	General purpose digital I/O pin
			UART1_RXD	<b>I</b>	UART1 Data receiver input pin
37			PE.8	<b>I/O</b>	General purpose digital I/O pin
			LCD_SEG9	<b>O</b>	LCD segment output 9 at LQFP128
38			PE.7	<b>I/O</b>	General purpose digital I/O pin
			LCD_SEG8	<b>O</b>	LCD segment output 8 at LQFP128
39					NC
40					NC
41					NC
42					NC
43					NC
44	17		PB.0	<b>I/O</b>	General purpose digital I/O pin
			UART0_RXD	<b>I</b>	UART0 Data receiver input pin
			SPI1_MOSI0	<b>I/O</b>	SPI1 1 <sup>st</sup> MOSI (Master Out, Slave In) pin
			LCD_SEG1	<b>O</b>	LCD segment output 1 at LQFP64 (or as LD_COM5)
			LCD_SEG7	<b>O</b>	LCD segment output 7 at LQFP128
45	18		PB.1	<b>I/O</b>	General purpose digital I/O pin
			UART0_TXD	<b>O</b>	UART0 Data transmitter output pin
			SPI1_MISO0	<b>I/O</b>	SPI1 1 <sup>st</sup> MISO (Master In, Slave Out) pin
			LCD_SEG0	<b>O</b>	LCD segment output 0 at LQFP64 (or as LCD_COM4)

Pin No.			Pin Name	Pin Type	Description
LQFP 128-pin	LQFP 64-pin	LQFP 48-pin			
			LCD_SEG6	O	LCD segment output 6 at LQFP128
46	19		PB.2	I/O	General purpose digital I/O pin
			UART0_RTSn	O	UART0 Request to Send output pin
			EBI_nWRL	O	EBI low byte write enable output pin
			SPI1_CLK	I/O	SPI1 serial clock pin
			LCD_COM3	O	LCD common output 3 at LQFP64
			LCD_SEG5	O	LCD segment output 5 at LQFP128
47	20		PB.3	I/O	General purpose digital I/O pin
			UART0_CTSn	I	UART0 Clear to Send input pin
			EBI_nWRH	O	EBI high byte write enable output pin
			SPI1_SS0	I/O	SPI1 1 <sup>st</sup> slave select pin
			LCD_COM2	O	LCD common output 2 at LQFP64
			LCD_SEG4	O	LCD segment output 4 at LQFP128
48	21		PD.6	I/O	General purpose digital I/O pin
			LCD_SEG3	O	LCD segment output 3 at LQFP128
49	22		PD.7	I/O	General purpose digital I/O pin
			LCD_SEG2	O	LCD segment output 2 at LQFP128
50	23		PD.14	I/O	General purpose digital I/O pin
			LCD_SEG1	O	LCD segment output 1 at LQFP128 (or as LCD_COM5)
51	24		PD.15	I/O	General purpose digital I/O pin
			LCD_SEG0	O	LCD segment output 0 at LQFP128 (or as LCD_COM4)
52			PC.5	I/O	General purpose digital I/O pin
			SPI0_MOSI1	I/O	SPI0 2 <sup>nd</sup> MOSI (Master Out, Slave In) pin
			LCD_COM3	O	LCD common output 3 at LQFP128
53			PC.4	I/O	General purpose digital I/O pin
			SPI0_MISO1	I/O	SPI0 2 <sup>nd</sup> MISO (Master In, Slave Out) pin
			LCD_COM2	O	LCD common output 2 at LQFP128
54	25		PC.3	I/O	General purpose digital I/O pin
			SPI0_MOSI0	I/O	SPI0 1 <sup>st</sup> MOSI (Master Out, Slave In) pin

Pin No.			Pin Name	Pin Type	Description
LQFP 128-pin	LQFP 64-pin	LQFP 48-pin			
			I2S_DO	O	I <sup>2</sup> S data output
			SC1_RST	O	SmartCard1 RST pin
			LCD_COM1	O	LCD common output 1 at LQFP64
			LCD_COM1	O	LCD common output 1 at LQFP128
55	26		PC.2	I/O	General purpose digital I/O pin
			SPI0_MISO0	I/O	SPI0 1 <sup>st</sup> MISO (Master In, Slave Out) pin
			I2S_DI	I	I <sup>2</sup> S data input
			SC1_PWR	O	SmartCard1 PWR pin
			LCD_COM0	O	LCD common output 0 at LQFP64
			LCD_COM0	O	LCD common output 0 at LQFP128
56	27		PC.1	I/O	General purpose digital I/O pin
			SPI0_CLK	I/O	SPI0 serial clock pin
			I2S_BCLK	I/O	I <sup>2</sup> S bit clock pin
			SC1_DAT	I/O	SmartCard1 DATA pin(SC1_UART_RXD)
			LCD_DH2	O	LCD external capacitor pin of charge pump circuit at LQFP64
			LCD_DH2	O	LCD external capacitor pin of charge pump circuit at LQFP128
57	28		PC.0 / MCLKO	I/O	General purpose digital I/O pin / Module clock output pin
			SPI0_SS0	I/O	SPI0 1 <sup>st</sup> slave select pin
			I2S_LRCLK	I/O	I <sup>2</sup> S left right channel clock
			SC1_CLK	O	SmartCard1 clock pin(SC1_UART_TXD)
			LCD_DH1	O	LCD external capacitor pin of charge pump circuit at LQFP64
			LCD_DH1	O	LCD external capacitor pin of charge pump circuit at LQFP128
58			PE.6	I/O	General purpose digital I/O pin
59	29		LCD_VLCD	AO	LCD power supply pin
60					NC
61			PE.5	I/O	General purpose digital I/O pin
62	30		PB.11	I/O	General purpose digital I/O pin
			PWM1_CH0	I/O	PWM1 Channel0 output

Pin No.			Pin Name	Pin Type	Description
LQFP 128-pin	LQFP 64-pin	LQFP 48-pin			
			TM3	O	Timer3 external counter input
			SC2_DAT	I/O	SmartCard2 DATA pin(SC2_UART_RXD)
			SPI0_MISO0	I/O	SPI0 1 <sup>st</sup> MISO (Master In, Slave Out) pin
			LCD_V1	O	Unit voltage for LCD charge pump circuit at LQFP64
			LCD_V1	O	LCD Unit voltage for LCD charge pump circuit at LQFP128
63	31		PB.10	I/O	General purpose digital I/O pin
			SPI0_SS1	I/O	SPI0 2 <sup>nd</sup> slave select pin
			TM2	O	Timer2 external counter input
			SC2_CLK	O	SmartCard2 clock pin(SC2_UART_TXD)
			SPI0_MOSI0	I/O	SPI0 1 <sup>st</sup> MOSI (Master Out, Slave In) pin
			LCD_V2	O	LCD driver biasing voltage at LQFP64
			LCD_V2	O	LCD driver biasing voltage at LQFP128
64	32		PB.9	I/O	General purpose digital I/O pin
			SPI1_SS1	I/O	SPI1 2 <sup>nd</sup> slave select pin
			TM1	O	Timer1 external counter input
			SC2_RST	O	SmartCard2 RST pin
			INT0	I	External interrupt0 input pin
			LCD_V3	O	LCD driver biasing voltage at LQFP64
			LCD_V3	O	LCD driver biasing voltage at LQFP128
65			PE.4	I/O	General purpose digital I/O pin
			SPI0_MOSI0	I/O	SPI0 1 <sup>st</sup> MOSI (Master Out, Slave In) pin
66			PE.3	I/O	General purpose digital I/O pin
			SPI0_MISO0	I/O	SPI0 1 <sup>st</sup> MISO (Master In, Slave Out) pin
67			PE.2	I/O	General purpose digital I/O pin
			SPI0_CLK	I/O	SPI0 serial clock pin
68			PE.1	I/O	General purpose digital I/O pin
			PWM1_CH3	I/O	PWM1 Channel3 output
			SPI0_SS0	I/O	SPI0 1 <sup>st</sup> slave select pin
69			PE.0	I/O	General purpose digital I/O pin



Pin No.			Pin Name	Pin Type	Description
LQFP 128-pin	LQFP 64-pin	LQFP 48-pin			
			PWM1_CH2	I/O	PWM1 Channel2 output
			I2S_MCLK	O	I <sup>2</sup> S master clock output pin
70			PC.13	I/O	General purpose digital I/O pin
			SPI1_MOSI1	I/O	SPI1 2 <sup>nd</sup> MOSI (Master Out, Slave In) pin
			PWM1_CH1	O	PWM1 Channel1 output
			SNOOPER	I	Snooper pin
			INT1	I	External interrupt 1
			I2C0_SCL	O	I <sup>2</sup> C0 clock pin
71			PC.12	I/O	General purpose digital I/O pin
			SPI1_MISO1	I/O	SPI1 2 <sup>nd</sup> MISO (Master In, Slave Out) pin
			PWM1_CH0	O	PWM1 Channel0 output
			INT0	I	External interrupt0 input pin
			I2C0_SDA	I/O	I <sup>2</sup> C0 data I/O pin
72	33		PC.11	I/O	General purpose digital I/O pin
			SPI1_MOSI0	I/O	SPI1 1 <sup>st</sup> MOSI (Master Out, Slave In) pin
			UART1_TXD	O	UART1 Data transmitter output pin
			LCD_SEG31	O	LCD segment output 31 at LQFP64
73	34		PC.10	I/O	General purpose digital I/O pin
			SPI1_MISO0	I/O	SPI1 1 <sup>st</sup> MISO (Master In, Slave Out) pin
			UART1_RXD	I	UART1 Data receiver input pin
			LCD_SEG30	O	LCD segment output 30 at LQFP64
74	35		PC.9	I/O	General purpose digital I/O pin
			SPI1_CLK	I/O	SPI1 serial clock pin
			I2C1_SCL	I/O	I <sup>2</sup> C1 clock pin
			LCD_SEG29	O	LCD segment output 29 at LQFP64
75	36		PC.8	I/O	General purpose digital I/O pin
			SPI1_SS0	I/O	SPI1 1 <sup>st</sup> slave select pin
			EBI_MCLK	O	EBI external clock output pin
			I2C1_SDA	I/O	I <sup>2</sup> C1 data I/O pin
			LCD_SEG28	O	LCD segment output 28 at LQFP64

Pin No.			Pin Name	Pin Type	Description
LQFP 128-pin	LQFP 64-pin	LQFP 48-pin			
76	37		PA.15	I/O	General purpose digital I/O pin
			PWM0_CH3	I/O	PWM0 Channel3 output
			I2S_MCLK	O	I <sup>2</sup> S master clock output pin
			TC3	I	Timer3 capture input
			SC0_PWR	O	SmartCard0 Power pin
			UART0_TXD	O	UART0 Data transmitter output pin
			LCD_SEG27	O	LCD segment output 27 at LQFP64
77	38		PA.14	I/O	General purpose digital I/O pin
			PWM0_CH2	I/O	PWM0 Channel2 output
			EBI_AD15	I/O	EBI Address/Data bus bit15
			TC2	I	Timer2 capture input
			UART0_RXD	I	UART0 Data receiver input pin
			LCD_SEG26	O	LCD segment output 26 at LQFP64
78	39		PA.13	I/O	General purpose digital I/O pin
			PWM0_CH1	I/O	PWM0 Channel1 output
			EBI_AD14	I/O	EBI Address/Data bus bit14
			TC1	I	Timer1 capture input
			I2C0_SCL	I/O	I <sup>2</sup> C0 clock pin
			LCD_SEG25	O	LCD segment output 25 at LQFP64
79	40		PA.12	I/O	General purpose digital I/O pin
			PWM0_CH0	I/O	PWM0 Channel0 output
			EBI_AD13	I/O	EBI Address/Data bus bit13
			TC0	I	Timer0 capture input
			I2C0_SDA	I/O	I <sup>2</sup> C0 data I/O pin
			LCD_SEG24	O	LCD segment output 24 at LQFP64
80	41		ICE_DAT	I/O	Serial Wired Debugger Data pin
			PF.0	I/O	General purpose digital I/O pin
			INT0	I	External interrupt0 input pin
81	42		ICE_CLK	I	Serial Wired Debugger Clock pin
			PF.1	I/O	General purpose digital I/O pin

Pin No.			Pin Name	Pin Type	Description
LQFP 128-pin	LQFP 64-pin	LQFP 48-pin			
			FCLKO	<b>O</b>	Frequency Divider output pin
			INT1	<b>I</b>	External interrupt1 input pin
82					NC
83			VDD	<b>P</b>	Power supply for I/O ports and LDO source for internal PLL and digital circuit
84					NC
85			VSS	<b>P</b>	Ground
86			VSS	<b>P</b>	Ground
87	43		AVSS	<b>AP</b>	Ground Pin for analog circuit
88			AVSS	<b>AP</b>	Ground Pin for analog circuit
89	44		PA.0	<b>I/O</b>	General purpose digital I/O pin
			AD0	<b>AI</b>	ADC analog input0
			SC2_CD	<b>I</b>	SmartCard2 card detect
90	45		PA.1	<b>I/O</b>	General purpose digital I/O pin
			AD1	<b>AI</b>	ADC analog input1
			EBI_AD12	<b>I/O</b>	EBI Address/Data bus bit12
91	46		PA.2	<b>I/O</b>	General purpose digital I/O pin
			AD2	<b>AI</b>	ADC analog input2
			EBI_AD11	<b>I/O</b>	EBI Address/Data bus bit11
			UART1_RXD	<b>I</b>	UART1 Data receiver input pin
			LCD_SEG23*	<b>AO</b>	LCD segment output 23 at LQFP64
92	47		PA.3	<b>I/O</b>	General purpose digital I/O pin
			AD3	<b>AI</b>	ADC analog input3
			EBI_AD10	<b>I/O</b>	EBI Address/Data bus bit10
			UART1_TXD	<b>O</b>	UART1 Data transmitter output pin
			LCD_SEG22*	<b>AO</b>	LCD segment output 22 at LQFP64
93	48		PA.4	<b>I/O</b>	General purpose digital I/O pin
			AD4	<b>AI</b>	ADC analog input4
			EBI_AD9	<b>I/O</b>	EBI Address/Data bus bit9
			SC2_PWR	<b>O</b>	SmartCard2 Power pin
			I2C0_SDA	<b>I/O</b>	I <sup>2</sup> C0 data I/O pin

Pin No.			Pin Name	Pin Type	Description
LQFP 128-pin	LQFP 64-pin	LQFP 48-pin			
			LCD_SEG21*	<b>AO</b>	LCD segment output 21 at LQFP64
			LCD_SEG39*	<b>AO</b>	LCD segment output 39 at LQFP128
94	49		PA.5	<b>I/O</b>	General purpose digital I/O pin
			AD5	<b>AI</b>	ADC analog input5
			EBI_AD8	<b>I/O</b>	EBI Address/Data bus bit8
			SC2_RST	<b>O</b>	SmartCard2 RST pin
			I2C0_SCL	<b>I/O</b>	I <sup>2</sup> C0 clock pin
			LCD_SEG20*	<b>AO</b>	LCD segment output 19 at LQFP64
			LCD_SEG38*	<b>AO</b>	LCD segment output 37 at LQFP128
95	50		PA.6	<b>I/O</b>	General purpose digital I/O pin
			AD6	<b>AI</b>	ADC analog input6
			EBI_AD7	<b>I/O</b>	EBI Address/Data bus bit7
			TC3	<b>I</b>	Timer3 capture input
			SC2_CLK	<b>O</b>	SmartCard2 clock pin(SC2_UART_TXD)
			PWM0_CH3	<b>O</b>	PWM0 Channel3 output
			LCD_SEG19*	<b>AO</b>	LCD segment output 19 at LQFP64
			LCD_SEG37*	<b>AO</b>	LCD segment output 37 at LQFP128
96			PA.7	<b>I/O</b>	General purpose digital I/O pin
			AD7	<b>AI</b>	ADC analog input7
			EBI_AD6	<b>I/O</b>	EBI Address/Data bus bit6
			TC2	<b>I</b>	Timer2 capture input
			SC2_DAT	<b>I/O</b>	SmartCard2 DATA pin(SC2_UART_RXD)
			PWM0_CH2	<b>O</b>	PWM0 Channel2 output
			LCD_SEG36*	<b>AO</b>	LCD segment output 36 output at LQFP128
97	51		VREF	<b>AP</b>	Voltage reference input for ADC
98					NC
99	52		AVDD	<b>AP</b>	Power supply for internal analog circuit
100			PD.0	<b>I/O</b>	General purpose digital I/O pin
			UART1_RXD	<b>I</b>	UART1 Data receiver input pin
			SPI2_SS0	<b>I/O</b>	SPI2 1 <sup>st</sup> slave select pin

Pin No.			Pin Name	Pin Type	Description
LQFP 128-pin	LQFP 64-pin	LQFP 48-pin			
			SC1_CLK	<b>O</b>	SmartCard1 clock pin(SC1_UART_TXD)
			AD8	<b>AI</b>	ADC analog input8
101			PD.1	<b>I/O</b>	General purpose digital I/O pin
			UART1_TXD	<b>O</b>	UART1 Data transmitter output pin
			SPI2_CLK	<b>I/O</b>	SPI2 serial clock pin
			SC1_DAT	<b>I/O</b>	SmartCard1 DATA pin(SC1_UART_RXD)
			AD9	<b>AI</b>	ADC analog input9
102			PD.2	<b>I/O</b>	General purpose digital I/O pin
			UART1_RTSn		UART1 Request to Send output pin
			I2S_LRCLK	<b>I/O</b>	I <sup>2</sup> S left right channel clock
			SPI2_MISO0	<b>I/O</b>	SPI2 1 <sup>st</sup> MISO (Master In, Slave Out) pin
			SC1_PWR	<b>O</b>	SmartCard1 Power pin
			AD10	<b>AI</b>	ADC analog input10
103			PD.3	<b>I/O</b>	General purpose digital I/O pin
			UART1_CTSn		UART1 Clear to Send input pin
			I2S_BCLK	<b>I/O</b>	I <sup>2</sup> S bit clock pin
			SPI2_MOSI0	<b>I/O</b>	SPI2 1 <sup>st</sup> MOSI (Master Out, Slave In) pin
			SC1_RST	<b>O</b>	SmartCard1 RST pin
			AD11	<b>AI</b>	ADC analog input11
104					NC
105			PD.4	<b>I/O</b>	General purpose digital I/O pin
			I2S_DI	<b>I</b>	I <sup>2</sup> S data input
			SPI2_MISO1	<b>I/O</b>	SPI2 2 <sup>nd</sup> MISO (Master In, Slave Out) pin
			SC1_CD	<b>I</b>	SmartCard1 card detect
			LCD_SEG35	<b>AO</b>	LCD segment output 35 at LQFP10
106			PD.5	<b>I/O</b>	General purpose digital I/O pin
			I2S_DO	<b>O</b>	I <sup>2</sup> S data output
			SPI2_MOSI1	<b>I/O</b>	SPI2 2 <sup>nd</sup> MOSI (Master Out, Slave In) pin
			LCD_SEG34	<b>AO</b>	LCD segment output 34 at LQFP128
107	53		PC.7	<b>I/O</b>	General purpose digital I/O pin

Pin No.			Pin Name	Pin Type	Description
LQFP 128-pin	LQFP 64-pin	LQFP 48-pin			
			DA1_OUT	<b>AO</b>	DAC 1 output
			EBI_AD5	<b>I/O</b>	EBI Address/Data bus bit5
			TC1	<b>I</b>	Timer1 capture input
			PWM0_CH1	<b>O</b>	PWM1 Channel1 output
			LCD_SEG17*	<b>AO</b>	LCD segment output 17 at LQFP64
108	54		PC.6	<b>I/O</b>	General purpose digital I/O pin
			DA0_OUT	<b>I</b>	DAC0 output
			EBI_AD4	<b>I/O</b>	EBI Address/Data bus bit4
			TC0	<b>I</b>	Timer0 capture input
			SC1_CD	<b>I</b>	SmartCard1 card detect pin
			PWM0_CH0	<b>O</b>	PWM0 Channel0 output
109	55		PC.15	<b>I/O</b>	General purpose digital I/O pin
			EBI_AD3	<b>I/O</b>	EBI Address/Data bus bit3
			TC0	<b>I</b>	Timer0 capture input
			PWM1_CH2	<b>O</b>	PWM1 Channel1 output
			LCD_SEG16	<b>AO</b>	LCD segment output 16 at LQFP64
			LCD_SEG33	<b>AO</b>	LCD segment output 33 at LQFP128
110	56		PC.14	<b>I/O</b>	General purpose digital I/O pin
			EBI_AD2	<b>I/O</b>	EBI Address/Data bus bit2
			PWM1_CH3	<b>I/O</b>	PWM1 Channel3 output
			LCD_SEG15	<b>AO</b>	LCD segment output 15 at LQFP64
			LCD_SEG32	<b>AO</b>	LCD segment output 32 at LQFP128
111	57		PB.15	<b>I/O</b>	General purpose digital I/O pin
			INT1	<b>I</b>	External interrupt1 input pin
			SNOOPER	<b>I</b>	Snooper pin
			LCD_SEG14	<b>AO</b>	LCD segment output 14 at LQFP64
			LCD_SEG31	<b>AO</b>	LCD segment output 31 at LQFP128
112					NC
113	58		XT1_IN	<b>O</b>	External 4~24 MHz crystal output pin
			PF.3	<b>I/O</b>	General purpose digital I/O pin

Pin No.			Pin Name	Pin Type	Description
LQFP 128-pin	LQFP 64-pin	LQFP 48-pin			
114	59		XT1_OUT	I	External 4~24 MHz crystal input pin
			PF.2	I/O	General purpose digital I/O pin
115					NC
116	60		nRESET	I	External reset input: Low active, set this pin low reset chip to initial state. With internal pull-up.
117	61		VSS	P	Ground
118			VSS	P	Ground
119					NC
120	62		VDD	P	Power supply for I/O ports and LDO source for internal PLL and digital circuit
121					NC
122			PF.4	I/O	General purpose digital I/O pin
			I2C0_SDA	I/O	I <sup>2</sup> C0 data I/O pin
123			PF.5	I/O	General purpose digital I/O pin
			I2C0_SCL	I/O	I <sup>2</sup> C0 clock pin
124			VSS	P	Ground
125	63		PVSS	P	PLL Ground
126	64		PB.8	I/O	General purpose digital I/O pin
			STADC	I	ADC external trigger input.
			TM0	I	Timer0 external counter input
			INT0	I	External interrupt0 input pin
			SC2_PWR	O	SmartCard2 Power pin
			LCD_SEG13	AO	LCD segment output 13 at LQFP64
			LCD_SEG30	AO	LCD segment output 30 at LQFP128
127			PE.15	I/O	General purpose digital I/O pin
			LCD_SEG29	O	LCD segment output 29 at LQFP128
128			PE.14	I/O	General purpose digital I/O pin
			LCD_SEG28	O	LCD segment output 28 at LQFP128

**Note:**

1. Pin Type: I = Digital Input, O=Digital Output; AI=Analog Input; AO= Analog Output; P=Power Pin; AP=Analog Power;
2. \* : Output voltage for ADC/LCD shared pins cannot be higher than VDD because these pins are without 5V tolerance.

3.4.3 NuMicro® Nano120 Pin Description

Pin No.			Pin Name	Pin Type	Description
LQFP 128	LQFP 64	LQFP 48			
1			PE.13	I/O	General purpose digital IO pin
2	1		PB.14	I/O	General purpose digital IO pin
			INT0	I	External interrupt0 input pin
			SC2_CD	I	SmartCard2 card detect
			SPI2_SS1	I/O	SPI2 2 <sup>nd</sup> slave select pin
3	2		PB.13	I/O	General purpose digital IO pin
			EBI_AD1	I/O	EBI Address/Data bus bit1
4	3	1	PB.12	I/O	General purpose digital IO pin
			EBI_AD0	I/O	EBI Address/Data bus bit0
			FCLKO	O	Frequency Divider output pin
5					NC
6	4	2	X32O	O	External 32.768 kHz crystal output pin
7	5	3	X32I	I	External 32.768 kHz crystal input pin
8					NC
9	6	4	PA.11	I/O	General purpose digital IO pin
			I2C1_SCL	I/O	I <sup>2</sup> C 1 clock pin
			EBI_nRD	O	EBI read enable output pin
			SC0_RST	O	SmartCard0 RST pin
			SPI2_MOSI0	I/O	SPI2 1 <sup>st</sup> MOSI (Master Out, Slave In) pin
10	7	5	PA.10	I/O	General purpose digital IO pin
			I2C1_SDA	I/O	I <sup>2</sup> C 1 data I/O pin
			EBI_nWR	O	EBI write enable output pin
			SC0_PWR	O	SmartCard0 Power pin
			SPI2_MISO0	I/O	SPI2 1 <sup>st</sup> MISO (Master In, Slave Out) pin
11	8	6	PA.9	I/O	General purpose digital IO pin
			I2C0_SCL	I/O	I <sup>2</sup> C 0 clock pin
			SC0_DAT	I/O	SmartCard0 DATA pin(SC0_UART_RXD)
			SPI2_CLK	I/O	SPI2 serial clock pin
12	9	7	PA.8	I/O	General purpose digital IO pin



Pin No.			Pin Name	Pin Type	Description
LQFP 128	LQFP 64	LQFP 48			
			I2C0_SDA	I/O	I <sup>2</sup> C 0 data I/O pin
			SC0_CLK	O	SmartCard0 clock pin(SC0_UART_TXD)
			SPI2_SS0	I/O	SPI2 1 <sup>st</sup> slave select pin
13			PD.8	I/O	General purpose digital IO pin
14			PD.9	I/O	General purpose digital IO pin
15			PD.10	I/O	General purpose digital IO pin
16			PD.11	I/O	General purpose digital IO pin
17			PD.12	I/O	General purpose digital IO pin
18			PD.13	I/O	General purpose digital IO pin
19	10	8	PB.4	I/O	General purpose digital IO pin
			UART1_RXD	I	UART1 Data receiver input pin
			SC0_CD	I	SmartCard0 card detect pin
			SPI2_SS0	I/O	SPI2 1 <sup>st</sup> slave select pin
20	11	9	PB.5	I/O	General purpose digital IO pin
			UART1_TXD	O	UART1 Data transmitter output pin
			SC0_RST	O	SmartCard0 RST pin
			SPI2_CLK	I/O	SPI2 serial clock pin
21	12		PB.6	I/O	General purpose digital IO pin
			UART1_nRTS	O	UART1 Request to Send output pin
			EBI_ALE	O	EBI address latch enable output pin
			SPI2_MISO0	I/O	SPI2 1 <sup>st</sup> MISO (Master In, Slave Out) pin
22	13		PB.7	I/O	General purpose digital IO pin
			UART1_nCTS	I	UART1 Clear to Send input pin
			EBI_nCS	O	EBI chip select enable output pin
			SPI2_MOSI0	I/O	SPI2 1 <sup>st</sup> MOSI (Master Out, Slave In) pin
23					NC
24	14	10	LDO_CAP	P	LDO output pin
25					NC
26					NC
27	15	11	VDD	P	Power supply for I/O ports and LDO source

Pin No.			Pin Name	Pin Type	Description
LQFP 128	LQFP 64	LQFP 48			
28					NC
29	16	12	VSS	<b>P</b>	Ground
30			VSS	<b>P</b>	Ground
31			VSS	<b>P</b>	Ground
32			VSS	<b>P</b>	Ground
33			PE.12	<b>I/O</b>	General purpose digital IO pin
34			PE.11	<b>I/O</b>	General purpose digital IO pin
35			PE.10	<b>I/O</b>	General purpose digital IO pin
36			PE.9	<b>I/O</b>	General purpose digital IO pin
37			PE.8	<b>I/O</b>	General purpose digital IO pin
38			PE.7	<b>I/O</b>	General purpose digital IO pin
39					NC
40	17	13	USB_VBUS	<b>USB</b>	POWER SUPPLY: From USB Host or HUB.
41	18	14	USB_VDD33_C AP	<b>USB</b>	Internal Power Regulator Output 3.3V Decoupling Pin
42	19	15	USB_D-	<b>USB</b>	USB Differential Signal D-
43	20	16	USB_D+	<b>USB</b>	USB Differential Signal D+
44	21	17	PB.0	<b>I/O</b>	General purpose digital IO pin
			UART0_RXD	<b>I</b>	UART0 Data receiver input pin
			SPI1_MOSI0	<b>I/O</b>	SPI1 1 <sup>st</sup> MOSI (Master Out, Slave In) pin
45	22	18	PB.1	<b>I/O</b>	General purpose digital IO pin
			UART0_TXD	<b>O</b>	UART0 Data transmitter output pin
			SPI1_MISO0	<b>I/O</b>	SPI1 1 <sup>st</sup> MISO (Master In, Slave Out) pin
46	23	19	PB.2	<b>I/O</b>	General purpose digital IO pin
			UART0_nRTS	<b>O</b>	UART0 Request to Send output pin
			EBI_nWRL	<b>O</b>	EBI low byte write enable output pin
			SPI1_CLK	<b>I/O</b>	SPI1 serial clock pin
47	24	20	PB.3	<b>I/O</b>	General purpose digital IO pin
			UART0_nCTS	<b>I</b>	UART0 Clear to Send input pin
			EBI_nWRH	<b>O</b>	EBI high byte write enable output pin
			SPI1_SS0	<b>I/O</b>	SPI1 1 <sup>st</sup> slave select pin

Pin No.			Pin Name	Pin Type	Description
LQFP 128	LQFP 64	LQFP 48			
48			PD.6	I/O	General purpose digital IO pin
49			PD.7	I/O	General purpose digital IO pin
50			PD.14	I/O	General purpose digital IO pin
51			PD.15	I/O	General purpose digital IO pin
52			PC.5	I/O	General purpose digital IO pin
			SPI0_MOSI1	I/O	SPI0 2 <sup>nd</sup> MOSI (Master Out, Slave In) pin
53			PC.4	I/O	General purpose digital IO pin
			SPI0_MISO1	I/O	SPI0 2 <sup>nd</sup> MISO (Master In, Slave Out) pin
54	25	21	PC.3	I/O	General purpose digital IO pin
			SPI0_MOSI0	I/O	SPI0 1 <sup>st</sup> MOSI (Master Out, Slave In) pin
			I2S_DO	O	I <sup>2</sup> S data output
			SC1_RST	O	SmartCard1 RST pin
55	26	22	PC.2	I/O	General purpose digital IO pin
			SPI0_MISO0	I/O	SPI0 1 <sup>st</sup> MISO (Master In, Slave Out) pin
			I2S_DI	I	I <sup>2</sup> S data input
			SC1_PWR	O	SmartCard1 PWR pin
56	27	23	PC.1	I/O	General purpose digital IO pin
			SPI0_CLK	I/O	SPI0 serial clock pin
			I2S_BCLK	I/O	I <sup>2</sup> S bit clock pin
			SC1_DAT	I/O	SmartCard1 DATA pin(SC1_UART_RXD)
57	28	24	PC.0 / MCLKO	I/O	General purpose digital IO pin / Module clock output pin
			SPI0_SS0	I/O	SPI0 1 <sup>st</sup> slave select pin
			I2S_LRCLK	I/O	I <sup>2</sup> S left right channel clock
			SC1_CLK	O	SmartCard1 clock pin(SC1_UART_TXD)
58			PE.6	I/O	General purpose digital IO pin
59					NC
60					NC
61	29		PE.5	I/O	General purpose digital IO pin
			PWM1_CH1	I/O	PWM1 Channel1 output
62	30		PB.11	I/O	General purpose digital IO pin

Pin No.			Pin Name	Pin Type	Description
LQFP 128	LQFP 64	LQFP 48			
			PWM1_CH0	I/O	PWM1 Channel0 output
			TM3	O	Timer3 external counter input
			SC2_DAT	I/O	SmartCard2 DATA pin(SC2_UART_RXD)
			SPI0_MISO0	I/O	SPI0 1 <sup>st</sup> MISO (Master In, Slave Out) pin
63	31		PB.10	I/O	General purpose digital IO pin
			SPI0_SS1	I/O	SPI0 2 <sup>nd</sup> slave select pin
			TM2	O	Timer2 external counter input
			SC2_CLK	O	SmartCard2 clock pin(SC2_UART_TXD)
			SPI0_MOSI0	I/O	SPI0 1 <sup>st</sup> MOSI (Master Out, Slave In) pin
64	32		PB.9	I/O	General purpose digital IO pin
			SPI1_SS1	I/O	SPI1 2 <sup>nd</sup> slave select pin
			TM1	O	Timer1 external counter input
			SC2_RST	O	SmartCard2 RST pin
			INT0	I	External interrupt0 input pin
65			PE.4	I/O	General purpose digital IO pin
			SPI0_MOSI0	I/O	SPI0 1 <sup>st</sup> MOSI (Master Out, Slave In) pin
66			PE.3	I/O	General purpose digital IO pin
			SPI0_MISO0	I/O	SPI0 1 <sup>st</sup> MISO (Master In, Slave Out) pin
67			PE.2	I/O	General purpose digital IO pin
			SPI0_CLK	I/O	SPI0 serial clock pin
68			PE.1	I/O	General purpose digital IO pin
			PWM1_CH3	I/O	PWM1 Channel3 output
			SPI0_SS0	I/O	SPI0 1 <sup>st</sup> slave select pin
69			PE.0	I/O	General purpose digital IO pin
			PWM1_CH2	I/O	PWM1 Channel2 output
			I2S_MCLK	O	I <sup>2</sup> S master clock output pin
70			PC.13	I/O	General purpose digital IO pin
			SPI1_MOSI1	I/O	SPI1 2 <sup>nd</sup> MOSI (Master Out, Slave In) pin
			PWM1_CH1	O	PWM1 Channel1 output
			SNOOPER	I	Snooper pin

Pin No.			Pin Name	Pin Type	Description
LQFP 128	LQFP 64	LQFP 48			
			INT1	I	External interrupt 1 input pin
			I2C0_SCL	O	I <sup>2</sup> C 0 clock pin
71			PC.12	I/O	General purpose digital IO pin
			SPI1_MISO1	I/O	SPI1 2 <sup>nd</sup> MISO (Master In, Slave Out) pin
			PWM1_CH0	O	PWM1 Channel 0 output
			INT0	I	External interrupt 0 input pin
			I2C0_SDA	I/O	I <sup>2</sup> C 0 data I/O pin
72	33		PC.11	I/O	General purpose digital IO pin
			SPI1_MOSI0	I/O	SPI1 1 <sup>st</sup> MOSI (Master Out, Slave In) pin
			UART1_TXD	O	UART1 Data transmitter output pin
73	34		PC.10	I/O	General purpose digital IO pin
			SPI1_MISO0	I/O	SPI1 1 <sup>st</sup> MISO (Master In, Slave Out) pin
			UART1_RXD	I	UART1 Data receiver input pin
74	35		PC.9	I/O	General purpose digital IO pin
			SPI1_CLK	I/O	SPI1 serial clock pin
			I2C1_SCL	I/O	I <sup>2</sup> C 1 clock pin
75	36		PC.8	I/O	General purpose digital IO pin
			SPI1_SS0	I/O	SPI1 1 <sup>st</sup> slave select pin
			EBI_MCLK	O	EBI external clock output pin
			I2C1_SDA	I/O	I <sup>2</sup> C 1 data I/O pin
76	37	25	PA.15	I/O	General purpose digital IO pin
			PWM0_CH3	I/O	PWM0 Channel3 output
			I2S_MCLK	O	I <sup>2</sup> S master clock output pin
			TC3	I	Timer3 capture input
			SC0_PWR	O	SmartCard0 Power pin
			UART0_TXD	O	UART0 Data transmitter output pin
77	38	26	PA.14	I/O	General purpose digital IO pin
			PWM0_CH2	I/O	PWM0 Channel2 output
			EBI_AD15	I/O	EBI Address/Data bus bit15
			TC2	I	Timer 2 capture input

Pin No.			Pin Name	Pin Type	Description
LQFP 128	LQFP 64	LQFP 48			
			UART0_RXD	I	UART0 Data receiver input pin
78	39	27	PA.13	I/O	General purpose digital IO pin
			PWM0_CH1	I/O	PWM0 Channel1 output
			EBI_AD14	I/O	EBI Address/Data bus bit14
			TC1	I	Timer1 capture input
			I2C0_SCL	I/O	I <sup>2</sup> C 0 clock pin
79	40	28	PA.12	I/O	General purpose digital IO pin
			PWM0_CH0	I/O	PWM0 Channel0 output
			EBI_AD13	I/O	EBI Address/Data bus bit13
			TC0	I	Timer 0 capture input
			I2C0_SDA	I/O	I <sup>2</sup> C 0 data I/O pin
80	41	29	ICE_DAT	I/O	Serial Wired Debugger Data pin
			PF.0	I/O	General purpose digital IO pin
			INT0	I	External interrupt0 input pin
81	42	30	ICE_CLK	I	Serial Wired Debugger Clock pin
			PF.1	I/O	General purpose digital IO pin
			FCLKO	O	Frequency Divider output pin
			INT1	I	External interrupt1 input pin
82					NC
83			VDD	P	Power supply for I/O ports and LDO source for internal PLL and digital circuit
84					NC
85			VSS	P	Ground
86			VSS	P	Ground
87	43	31	AVSS	AP	Ground Pin for analog circuit
88			AVSS	AP	Ground Pin for analog circuit
89	44	32	PA.0	I/O	General purpose digital IO pin
			AD0	AI	ADC analog input0
			SC2_CD	I	SmartCard2 card detect
90	45	33	PA.1	I/O	General purpose digital IO pin
			AD1	AI	ADC analog input1

Pin No.			Pin Name	Pin Type	Description
LQFP 128	LQFP 64	LQFP 48			
			EBI_AD12	I/O	EBI Address/Data bus bit12
91	46	34	PA.2	I/O	General purpose digital IO pin
			AD2	AI	ADC analog input2
			EBI_AD11	I/O	EBI Address/Data bus bit11
			UART1_RXD	I	UART1 Data receiver input pin
92	47	35	PA.3	I/O	General purpose digital IO pin
			AD3	AI	ADC analog input3
			EBI_AD10	I/O	EBI Address/Data bus bit10
			UART1_TXD	O	UART1 Data transmitter output pin
93	48	36	PA.4	I/O	Digital GPIO pin
			AD4	AI	ADC analog input4
			EBI_AD9	I/O	EBI Address/Data bus bit9
			SC2_PWR	O	SmartCard2 Power pin
			I2C0_SDA	I/O	I <sup>2</sup> C 0 data I/O pin
94	49	37	PA.5	I/O	General purpose digital IO pin
			AD5	AI	ADC analog input5
			EBI_AD8	I/O	EBI Address/Data bus bit8
			SC2_RST	O	SmartCard2 RST pin
			I2C0_SCL	I/O	I <sup>2</sup> C 0 clock pin
95	50	38	PA.6	I/O	General purpose digital IO pin
			AD6	AI	ADC analog input6
			EBI_AD7	I/O	EBI Address/Data bus bit7
			TC3	I	Timer3 capture input
			SC2_CLK	O	SmartCard2 clock pin(SC2_UART_TXD)
			PWM0_CH3	O	PWM0 Channel3 output
96			PA.7	I/O	General purpose digital IO pin
			AD7	AI	ADC analog input7
			EBI_AD6	I/O	EBI Address/Data bus bit6
			TC2	I	Timer2 capture input
			SC2_DAT	I/O	SmartCard2 DATA pin(SC2_UART_RXD)

Pin No.			Pin Name	Pin Type	Description
LQFP 128	LQFP 64	LQFP 48			
			PWM0_CH2	<b>O</b>	PWM0 Channel2 output
97	51	39	VREF	<b>AP</b>	Voltage reference input for ADC
98					NC
99	52	40	AVDD	<b>AP</b>	Power supply for internal analog circuit
100			PD.0	<b>I/O</b>	General purpose digital IO pin
			UART1_RXD	<b>I</b>	UART1 Data receiver input pin
			SPI2_SS0	<b>I/O</b>	SPI2 1 <sup>st</sup> slave select pin
			SC1_CLK	<b>O</b>	SmartCard1 clock pin(SC1_UART_TXD)
			AD8	<b>AI</b>	ADC analog input8
101			PD.1	<b>I/O</b>	General purpose digital IO pin
			UART1_TXD	<b>O</b>	UART1 Data transmitter output pin
			SPI2_CLK	<b>I/O</b>	SPI2 serial clock pin
			SC1_DAT	<b>I/O</b>	SmartCard1 DATA pin(SC1_UART_RXD)
			AD9	<b>AI</b>	ADC analog input9
102			PD.2	<b>I/O</b>	General purpose digital IO pin
			UART1_nRTS	<b>O</b>	UART1 Request to Send output pin
			I2S_LRCLK	<b>I/O</b>	I <sup>2</sup> S left right channel clock
			SPI2_MISO0	<b>I/O</b>	SPI2 1 <sup>st</sup> MISO (Master In, Slave Out) pin
			SC1_PWR	<b>O</b>	SmartCard1 Power pin
			AD10	<b>AI</b>	ADC analog input10
103			PD.3	<b>I/O</b>	General purpose digital IO pin
			UART1_nCTS	<b>I</b>	UART1 Clear to Send input pin
			I2S_BCLK	<b>I/O</b>	I <sup>2</sup> S bit clock pin
			SPI2_MOSI0	<b>I/O</b>	SPI2 1 <sup>st</sup> MOSI (Master Out, Slave In) pin
			SC1_RST	<b>O</b>	SmartCard1 RST pin
			AD11	<b>AI</b>	ADC analog input11
104					NC
105			PD.4	<b>I/O</b>	General purpose digital IO pin
			I2S_DI	<b>I</b>	I <sup>2</sup> S data input
			SPI2_MISO1	<b>I/O</b>	SPI2 2 <sup>nd</sup> MISO (Master In, Slave Out) pin



Pin No.			Pin Name	Pin Type	Description
LQFP 128	LQFP 64	LQFP 48			
			SC1_CD	I	SmartCard1 card detect
106			PD.5	I/O	General purpose digital IO pin
			I2S_DO	O	I <sup>2</sup> S data output
			SPI2_MOSI1	I/O	SPI2 2 <sup>nd</sup> MOSI (Master Out, Slave In) pin
107	53	41	PC.7	I/O	General purpose digital IO pin
			DA1+OUT	AO	DAC 1 output
			EBI_AD5	I/O	EBI Address/Data bus bit5
			TC1	I	Timer1 capture input
			PWM0_CH1	O	PWM1 Channel1 output
108	54	42	PC.6	I/O	General purpose digital IO pin
			DA0_OUT	I	DAC0 output
			EBI_AD4	I/O	EBI Address/Data bus bit4
			TC0	I	Timer 0 capture input
			SC1_CD		SmartCard1 card detect pin
			PWM0_CH0	O	PWM0 Channel0 output
109	55		PC.15	I/O	General purpose digital IO pin
			EBI_AD3	I/O	EBI Address/Data bus bit3
			TC0	I	Timer0 capture input
			PWM1_CH2	O	PWM1 Channel1 output
110	56		PC.14	I/O	General purpose digital IO pin
			EBI_AD2	I/O	EBI Address/Data bus bit2
			PWM1_CH3	I/O	PWM1 Channel3 output
111	57	43	PB.15	I/O	General purpose digital IO pin
			INT1	I	External interrupt1 input pin
			SNOOPER	I	Snooper pin
			SC1_CD	I	SmartCard1 card detect
112					NC
113	58	44	XT1_IN	O	External 4~24 MHz crystal output pin
			PF.3	I/O	General purpose digital I/O pin
114	59	45	XT1_OUT	I	External 4~24 MHz crystal input pin

Pin No.			Pin Name	Pin Type	Description
LQFP 128	LQFP 64	LQFP 48			
			PF.2	I/O	General purpose digital I/O pin
115					NC
116	60	46	nRESET	I	External reset input: Low active, set this pin low reset chip to initial state. With internal pull-up.
117	61		VSS	P	Ground
118			VSS	P	Ground
119					NC
120	62		VDD	P	Power supply for I/O ports and LDO source for internal PLL and digital circuit
121					NC
122			PF.4	I/O	General purpose digital IO pin
			I2C0_SDA	I/O	I <sup>2</sup> C 0 data I/O pin
123			PF.5	I/O	General purpose digital IO pin
			I2C0_SCL	I/O	I <sup>2</sup> C 0 clock pin
124			VSS	P	Ground
125	63	47	PVSS	P	PLL Ground
126	64	48	PB.8	I/O	General purpose digital IO pin
			STADC	I	ADC external trigger input.
			TM0	I	Timer0 external counter input
			INT0	I	External interrupt0 input pin
			SC2_PWR	O	SmartCard2 Power pin
127			PE.15	I/O	General purpose digital IO pin
128			PE.14	I/O	General purpose digital IO pin

**Note:**

1. Pin Type: I = Digital Input, O=Digital Output; AI=Analog Input; AO= Analog Output; P=Power Pin; AP=Analog Power;

3.4.4 NuMicro® Nano130 Pin Description

Pin No.			Pin Name	Pin Type	Description
LQFP 128-pin	LQFP 64-pin	LQFP 48-pin			
1			PE.13	I/O	General purpose digital I/O pin
			LCD_SEG27	O	LCD segment output 27 at LQFP128
2	1		PB.14	I/O	General purpose digital I/O pin
			INT0	I	External interrupt0 input pin
			SC2_CD	I	SmartCard2 card detect
			SPI2_SS1	I/O	SPI2 2 <sup>nd</sup> slave select pin
			LCD_SEG12	O	LCD segment output 12 at LQFP64
			LCD_SEG26	O	LCD segment output 26 at LQFP128
3	2		PB.13	I/O	General purpose digital I/O pin
			EBI_AD1	I/O	EBI Address/Data bus bit1
			LCD_SEG11	O	LCD segment output 11 at LQFP64
			LCD_SEG25	O	LCD segment output 25 at LQFP128
4	3		PB.12	I/O	General purpose digital I/O pin
			EBI_AD0	I/O	EBI Address/Data bus bit0
			FCLKO	O	Frequency Divider output pin
			LCD_SEG10	O	LCD segment output 10 at LQFP64
			LCD_SEG24	O	LCD segment output 24 at LQFP128
5					NC
6	4		X32O	O	External 32.768 kHz crystal output pin
7	5		X32I	I	External 32.768 kHz crystal input pin
8					NC
9	6		PA.11	I/O	General purpose digital I/O pin
			I2C1_SCL	I/O	I <sup>2</sup> C1 clock pin
			EBI_nRD	O	EBI read enable output pin
			SC0_RST	O	SmartCard0 RST pin
			SPI2_MOSI0	I/O	SPI2 1 <sup>st</sup> MOSI (Master Out, Slave In) pin
			LCD_SEG9	O	LCD segment output 9 at LQFP64
			LCD_SEG23	O	LCD segment output 23 at LQFP128
10	7		PA.10	I/O	General purpose digital I/O pin
			I2C1_SDA	I/O	I <sup>2</sup> C1 data I/O pin

Pin No.			Pin Name	Pin Type	Description
LQFP 128-pin	LQFP 64-pin	LQFP 48-pin			
			EBI_nWR	O	EBI write enable output pin
			SC0_PWR	O	SmartCard0 Power pin
			SPI2_MISO0	I/O	SPI2 1 <sup>st</sup> MISO (Master In, Slave Out) pin
			LCD_SEG8	O	LCD segment output 8 at LQFP64
			LCD_SEG22	O	LCD segment output 22 at LQFP128
11	8		PA.9	I/O	General purpose digital I/O pin
			I2C0_SCL	I/O	I <sup>2</sup> C0 clock pin
			SC0_DAT	I/O	SmartCard0 DATA pin(SC0_UART_RXD)
			SPI2_CLK	I/O	SPI2 serial clock pin
			LCD_SEG7	O	LCD segment output 7 at LQFP64
			LCD_SEG21	O	LCD segment output 21 at LQFP128
12	9		PA.8	I/O	General purpose digital I/O pin
			I2C0_SDA	I/O	I <sup>2</sup> C0 data I/O pin
			SC0_CLK	O	SmartCard0 clock pin(SC0_UART_TXD)
			SPI2_SS0	I/O	SPI2 1 <sup>st</sup> slave select pin
			LCD_SEG6	O	LCD segment output 6 at LQFP64
			LCD_SEG20	O	LCD segment output 20 at LQFP128
13			PD.8	I/O	General purpose digital I/O pin
			LCD_SEG19	O	LCD segment output 19 at LQFP128
14			PD.9	I/O	General purpose digital I/O pin
			LCD_SEG18	O	LCD segment output 18 at LQFP128
15			PD.10	I/O	General purpose digital I/O pin
			LCD_SEG17	O	LCD segment output 17 at LQFP128
16			PD.11	I/O	General purpose digital I/O pin
			LCD_SEG16	O	LCD segment output 16 at LQFP128
17			PD.12	I/O	General purpose digital I/O pin
			LCD_SEG15	O	LCD segment output 15 at LQFP128
18			PD.13	I/O	General purpose digital I/O pin
			LCD_SEG14	O	LCD segment output 14 at LQFP128
19	10		PB.4	I/O	General purpose digital I/O pin

Pin No.			Pin Name	Pin Type	Description
LQFP 128-pin	LQFP 64-pin	LQFP 48-pin			
			UART1_RXD	I	UART1 Data receiver input pin
			SC0_CD	I	SmartCard0 card detect pin
			SPI2_SS0	I/O	SPI2 1 <sup>st</sup> slave select pin
			LCD_SEG5	O	LCD segment output 5 at LQFP64
			LCD_SEG13	O	LCD segment output 13 at LQFP128
20	11		PB.5	I/O	General purpose digital I/O pin
			UART1_TXD	O	UART1 Data transmitter output pin
			SC0_RST	O	SmartCard0 RST pin
			SPI2_CLK	I/O	SPI2 serial clock pin
			LCD_SEG4	O	LCD segment output 4 at LQFP64
			LCD_SEG12	O	LCD segment output 12 at LQFP128
21	12		PB.6	I/O	General purpose digital I/O pin
			UART1_RTSn	O	UART1 Request to Send output pin
			EBI_ALE	O	EBI address latch enable output pin
			SPI2_MISO0	I/O	SPI2 1 <sup>st</sup> MISO (Master In, Slave Out) pin
			LCD_SEG3	O	LCD segment output 3 at LQFP64
			LCD_SEG11	O	LCD segment output 11 at LQFP128
22	13		PB.7	I/O	General purpose digital I/O pin
			UART1_CTSn	I	UART1 Clear to Send input pin
			EBI_nCS	O	EBI chip select enable output pin
			SPI2_MOSI0	I/O	SPI2 1 <sup>st</sup> MOSI (Master Out, Slave In) pin
			LCD_SEG2	O	LCD segment output 2 at LQFP64
			LCD_SEG10	O	LCD segment output 10 at LQFP128
23					NC
24	14		LDO_CAP	P	LDO output pin
25					NC
26					NC
27	15		VDD	P	Power supply for I/O ports and LDO source
28					NC
29	16		VSS	P	Ground

Pin No.			Pin Name	Pin Type	Description
LQFP 128-pin	LQFP 64-pin	LQFP 48-pin			
30			VSS	P	Ground
31			VSS	P	Ground
32			VSS	P	Ground
33			PE.12	I/O	General purpose digital I/O pin
34			PE.11	I/O	General purpose digital I/O pin
35			PE.10	I/O	General purpose digital I/O pin
36			PE.9	I/O	General purpose digital I/O pin
37			PE.8	I/O	General purpose digital I/O pin
			LCD_SEG9	O	LCD segment output 9 at LQFP128
38			PE.7	I/O	General purpose digital I/O pin
			LCD_SEG8	O	LCD segment output 8 at LQFP128
39					NC
40	17		USB_VBUS	USB	POWER SUPPLY: From USB Host or HUB.
41	18		USB_VDD33_CAP	USB	Internal Power Regulator Output 3.3V Decoupling Pin
42	19		USB_D-	USB	USB Differential Signal D-
43	20		USB_D+	USB	USB Differential Signal D+
44	21		PB.0	I/O	General purpose digital I/O pin
			UART0_RXD	I	UART0 Data receiver input pin
			SPI1_MOSI0	I/O	SPI1 1 <sup>st</sup> MOSI (Master Out, Slave In) pin
			LCD_SEG1	O	LCD segment output 1 at LQFP64 (or as LCD_COM5)
			LCD_SEG7	O	LCD segment output 7 at LQFP128
45	22		PB.1	I/O	General purpose digital I/O pin
			UART0_TXD	O	UART0 Data transmitter output pin
			SPI1_MISO0	I/O	SPI1 1 <sup>st</sup> MISO (Master In, Slave Out) pin
			LCD_SEG0	O	LCD segment output 0 at LQFP64 (or as LCD_COM4)
			LCD_SEG6	O	LCD segment output 6 at LQFP128
46	23		PB.2	I/O	General purpose digital I/O pin
			UART0_RTSn	O	UART0 Request to Send output pin
			EBI_nWRL	O	EBI low byte write enable output pin

Pin No.			Pin Name	Pin Type	Description
LQFP 128-pin	LQFP 64-pin	LQFP 48-pin			
			SPI1_CLK	I/O	SPI1 serial clock pin
			LCD_COM3	O	LCD common output 3 at LQFP64
			LCD_SEG5	O	LCD segment output 5 at LQFP128
47	24		PB.3	I/O	General purpose digital I/O pin
			UART0_CTSn	I	UART0 Clear to Send input pin
			EBI_nWRH	O	EBI high byte write enable output pin
			SPI1_SS0	I/O	SPI1 1 <sup>st</sup> slave select pin
			LCD_COM2	O	LCD common output 2 at LQFP64
			LCD_SEG4	O	LCD segment output 4 at LQFP128
48			PD.6	I/O	General purpose digital I/O pin
			LCD_SEG3	O	LCD segment output 3 at LQFP128
49			PD.7	I/O	General purpose digital I/O pin
			LCD_SEG2	O	LCD segment output 2 at LQFP128
50			PD.14	I/O	General purpose digital I/O pin
			LCD_SEG1	O	LCD segment output 1 at LQFP128 (or as LCD_COM5)
51			PD.15	I/O	General purpose digital I/O pin
			LCD_SEG0	O	LCD segment output 0 at LQFP128 (or as LCD_COM4)
52			PC.5	I/O	General purpose digital I/O pin
			SPI0_MOSI1	I/O	SPI0 2 <sup>nd</sup> MOSI (Master Out, Slave In) pin
			LCD_COM3	O	LCD common output 3 at LQFP128
53			PC.4	I/O	General purpose digital I/O pin
			SPI0_MISO1	I/O	SPI0 2 <sup>nd</sup> MISO (Master In, Slave Out) pin
			LCD_COM2	O	LCD common output 2 at LQFP128
54	25		PC.3	I/O	General purpose digital I/O pin
			SPI0_MOSI0	I/O	SPI0 1 <sup>st</sup> MOSI (Master Out, Slave In) pin
			I2S_DO	O	I <sup>2</sup> S data output
			SC1_RST	O	SmartCard1 RST pin
			LCD_COM1	O	LCD common output 1 at LQFP64
			LCD_COM1	O	LCD common output 1 at LQFP128

Pin No.			Pin Name	Pin Type	Description
LQFP 128-pin	LQFP 64-pin	LQFP 48-pin			
55	26		PC.2	I/O	General purpose digital I/O pin
			SPI0_MISO0	I/O	SPI0 1 <sup>st</sup> MISO (Master In, Slave Out) pin
			I2S_DI	I	I <sup>2</sup> S data input
			SC1_PWR	O	SmartCard1 PWR pin
			LCD_COM0	O	LCD common output 0 at LQFP64
			LCD_COM0	O	LCD common output 0 at LQFP128
56	27		PC.1	I/O	General purpose digital I/O pin
			SPI0_CLK	I/O	SPI0 serial clock pin
			I2S_BCLK	I/O	I <sup>2</sup> S bit clock pin
			SC1_DAT	I/O	SmartCard1 DATA pin(SC1_UART_RXD)
			LCD_DH2	O	LCD external capacitor pin of charge pump circuit at LQFP64
			LCD_DH2	O	LCD external capacitor pin of charge pump circuit at LQFP128
57	28		PC.0 / MCLKO	I/O	General purpose digital I/O pin / Module clock output pin
			SPI0_SS0	I/O	SPI0 1 <sup>st</sup> slave select pin
			I2S_LRCLK	I/O	I <sup>2</sup> S left right channel clock
			SC1_CLK	O	SmartCard1 clock pin(SC1_UART_TXD)
			LCD_DH1	O	LCD external capacitor pin of charge pump circuit at LQFP64
			LCD_DH1	O	LCD external capacitor pin of charge pump circuit at LQFP128
58			PE.6	I/O	General purpose digital I/O pin
59	29		LCD_VLCD	AO	LCD power supply pin
60					NC
61			PE.5		General purpose digital I/O pin
62	30		PB.11	I/O	General purpose digital I/O pin
			PWM1_CH0	I/O	PWM1 Channel0 output
			TM3	O	Timer3 external counter input
			SC2_DAT	I/O	SmartCard2 DATA pin(SC2_UART_RXD)
			SPI0_MISO0	I/O	SPI0 1 <sup>st</sup> MISO (Master In, Slave Out) pin



Pin No.			Pin Name	Pin Type	Description
LQFP 128-pin	LQFP 64-pin	LQFP 48-pin			
			LCD_V1	O	LCD Unit voltage for LCD charge pump circuit at LQFP64
			LCD_V1	O	LCD Unit voltage for LCD charge pump circuit at LQFP128
63	31		PB.10	I/O	General purpose digital I/O pin
			SPI0_SS1	I/O	SPI0 2 <sup>nd</sup> slave select pin
			TM2	O	Timer2 external counter input
			SC2_CLK	O	SmartCard2 clock pin(SC2_UART_TXD)
			SPI0_MOSI0	I/O	SPI0 1 <sup>st</sup> MOSI (Master Out, Slave In) pin
			LCD_V2	O	LCD driver biasing voltage at LQFP64
			LCD_V2	O	LCD driver biasing voltage at LQFP128
64	32		PB.9	I/O	General purpose digital I/O pin
			SPI1_SS1	I/O	SPI1 2 <sup>nd</sup> slave select pin
			TM1	O	Timer1 external counter input
			SC2_RST	O	SmartCard2 RST pin
			INT0	I	External interrupt0 input pin
			LCD_V3	O	LCD driver biasing voltage at LQFP64
			LCD_V3	O	LCD driver biasing voltage at LQFP128
65			PE.4	I/O	General purpose digital I/O pin
			SPI0_MOSI0	I/O	SPI0 1 <sup>st</sup> MOSI (Master Out, Slave In) pin
66			PE.3	I/O	General purpose digital I/O pin
			SPI0_MISO0	I/O	SPI0 1 <sup>st</sup> MISO (Master In, Slave Out) pin
67			PE.2	I/O	General purpose digital I/O pin
			SPI0_CLK	I/O	SPI0 serial clock pin
68			PE.1	I/O	General purpose digital I/O pin
			PWM1_CH3	I/O	PWM1 Channel3 output
			SPI0_SS0	I/O	SPI0 1 <sup>st</sup> slave select pin
69			PE.0	I/O	General purpose digital I/O pin
			PWM1_CH2	I/O	PWM1 Channel2 output
			I2S_MCLK	O	I <sup>2</sup> S master clock output pin
70			PC.13	I/O	General purpose digital I/O pin

Pin No.			Pin Name	Pin Type	Description
LQFP 128-pin	LQFP 64-pin	LQFP 48-pin			
			SPI1_MOSI1	I/O	SPI1 2 <sup>nd</sup> MOSI (Master Out, Slave In) pin
			PWM1_CH1	O	PWM1 Channel1 output
			SNOOPER	I	Snooper pin
			INT1	I	External interrupt 1 input pin
			I2C0_SCL	O	I <sup>2</sup> C0 clock pin
71			PC.12	I/O	General purpose digital I/O pin
			SPI1_MISO1	I/O	SPI1 2 <sup>nd</sup> MISO (Master In, Slave Out) pin
			PWM1_CH0	O	PWM1 Channel0 output
			INT0	I	External interrupt0 input pin
			I2C0_SDA	I/O	I <sup>2</sup> C0 data I/O pin
72	33		PC.11	I/O	General purpose digital I/O pin
			SPI1_MOSI0	I/O	SPI1 1 <sup>st</sup> MOSI (Master Out, Slave In) pin
			UART1_TXD	O	UART1 Data transmitter output pin
			LCD_SEG31	O	LCD segment output 31 at LQFP64
73	34		PC.10	I/O	General purpose digital I/O pin
			SPI1_MISO0	I/O	SPI1 1 <sup>st</sup> MISO (Master In, Slave Out) pin
			UART1_RXD	I	UART1 Data receiver input pin
			LCD_SEG30	O	LCD segment output 30 at LQFP64
74	35		PC.9	I/O	General purpose digital I/O pin
			SPI1_CLK	I/O	SPI1 serial clock pin
			I2C1_SCL	I/O	I <sup>2</sup> C1 clock pin
			LCD_SEG29	O	LCD segment output 29 at LQFP64
75	36		PC.8	I/O	General purpose digital I/O pin
			SPI1_SS0	I/O	SPI1 1 <sup>st</sup> slave select pin
			EBI_MCLK	O	EBI external clock output pin
			I2C1_SDA	I/O	I <sup>2</sup> C1 data I/O pin
			LCD_SEG28	O	LCD segment output 28 at LQFP64
76	37		PA.15	I/O	General purpose digital I/O pin
			PWM0_CH3	I/O	PWM0 Channel3 output
			I2S_MCLK	O	I <sup>2</sup> S master clock output pin

Pin No.			Pin Name	Pin Type	Description
LQFP 128-pin	LQFP 64-pin	LQFP 48-pin			
			TC3	I	Timer3 capture input
			SC0_PWR	O	SmartCard0 Power pin
			UART0_TXD	O	UART0 Data transmitter output pin
			LCD_SEG27	O	LCD segment output 27 at LQFP64
77	38		PA.14	I/O	General purpose digital I/O pin
			PWM0_CH2	I/O	PWM0 Channel2 output
			EBI_AD15	I/O	EBI Address/Data bus bit15
			TC2	I	Timer2 capture input
			UART0_RXD	I	UART0 Data receiver input pin
			LCD_SEG26	O	LCD segment output 26 at LQFP64
78	39		PA.13	I/O	General purpose digital I/O pin
			PWM0_CH1	I/O	PWM0 Channel1 output
			EBI_AD14	I/O	EBI Address/Data bus bit14
			TC1	I	Timer1 capture input
			I2C0_SCL	I/O	I <sup>2</sup> C0 clock pin
			LCD_SEG25	O	LCD segment output 25 at LQFP64
79	40		PA.12	I/O	General purpose digital I/O pin
			PWM0_CH0	I/O	PWM0 Channel0 output
			EBI_AD13	I/O	EBI Address/Data bus bit13
			TC0	I	Timer0 capture input
			I2C0_SDA	I/O	I <sup>2</sup> C0 data I/O pin
			LCD_SEG24	O	LCD segment output 24 at LQFP64
80	41		ICE_DAT	I/O	Serial Wired Debugger Data pin
			PF.0	I/O	General purpose digital I/O pin
			INT0	I	External interrupt0 input pin
81	42		ICE_CLK	I	Serial Wired Debugger Clock pin
			PF.1	I/O	General purpose digital I/O pin
			FCLKO	O	Frequency Divider output pin
			INT1	I	External interrupt1 input pin
82					NC

Pin No.			Pin Name	Pin Type	Description
LQFP 128-pin	LQFP 64-pin	LQFP 48-pin			
83			VDD	<b>P</b>	Power supply for I/O ports and LDO source for internal PLL and digital circuit
84					NC
85			VSS	<b>P</b>	Ground
86			VSS	<b>P</b>	Ground
87	43		AVSS	<b>AP</b>	Ground Pin for analog circuit
88			AVSS	<b>AP</b>	Ground Pin for analog circuit
89	44		PA.0	<b>I/O</b>	General purpose digital I/O pin
			AD0	<b>AI</b>	ADC analog input0
			SC2_CD	<b>I</b>	SmartCard2 card detect
90	45		PA.1	<b>I/O</b>	General purpose digital I/O pin
			AD1	<b>AI</b>	ADC analog input1
			EBI_AD12	<b>I/O</b>	EBI Address/Data bus bit12
91	46		PA.2	<b>I/O</b>	General purpose digital I/O pin
			AD2	<b>AI</b>	ADC analog input2
			EBI_AD11	<b>I/O</b>	EBI Address/Data bus bit11
			UART1_RXD	<b>I</b>	UART1 Data receiver input pin
			LCD_SEG23*	<b>AO</b>	LCD segment output 23 at LQFP64
92	47		PA.3	<b>I/O</b>	General purpose digital I/O pin
			AD3	<b>AI</b>	ADC analog input3
			EBI_AD10	<b>I/O</b>	EBI Address/Data bus bit10
			UART1_TXD	<b>O</b>	UART1 Data transmitter output pin
			LCD_SEG22*	<b>AO</b>	LCD segment output 22 at LQFP64
93	48		PA.4	<b>I/O</b>	General purpose digital I/O pin
			AD4	<b>AI</b>	ADC analog input4
			EBI_AD9	<b>I/O</b>	EBI Address/Data bus bit9
			SC2_PWR	<b>O</b>	SmartCard2 Power pin
			I2C0_SDA	<b>I/O</b>	I <sup>2</sup> C0 data I/O pin
			LCD_SEG21*	<b>AO</b>	LCD segment output 21 at LQFP64
			LCD_SEG39*	<b>AO</b>	LCD segment output 39 at LQFP128
94	49		PA.5	<b>I/O</b>	General purpose digital I/O pin

Pin No.			Pin Name	Pin Type	Description
LQFP 128-pin	LQFP 64-pin	LQFP 48-pin			
			AD5	<b>AI</b>	ADC analog input5
			EBI_AD8	<b>I/O</b>	EBI Address/Data bus bit8
			SC2_RST	<b>O</b>	SmartCard2 RST pin
			I2C0_SCL	<b>I/O</b>	I <sup>2</sup> C0 clock pin
			LCD_SEG20*	<b>AO</b>	LCD segment output 20 at LQFP64
			LCD_SEG38*	<b>AO</b>	LCD segment output 38 at LQFP128
95	50		PA.6	<b>I/O</b>	General purpose digital I/O pin
			AD6	<b>AI</b>	ADC analog input6
			EBI_AD7	<b>I/O</b>	EBI Address/Data bus bit7
			TC3	<b>I</b>	Timer3 capture input
			SC2_CLK	<b>O</b>	SmartCard2 clock pin(SC2_UART_TXD)
			PWM0_CH3	<b>O</b>	PWM0 Channel3 output
			LCD_SEG19*	<b>AO</b>	LCD segment output 19 at LQFP64
			LCD_SEG37*	<b>AO</b>	LCD segment output 37 at LQFP128
96			PA.7	<b>I/O</b>	General purpose digital I/O pin
			AD7	<b>AI</b>	ADC analog input7
			EBI_AD6	<b>I/O</b>	EBI Address/Data bus bit6
			TC2	<b>I</b>	Timer2 capture input
			SC2_DAT	<b>I/O</b>	SmartCard2 DATA pin(SC2_UART_RXD)
			PWM0_CH2	<b>O</b>	PWM0 Channel2 output
			LCD_SEG36*	<b>AO</b>	LCD segment output 36 output at LQFP128
97	51		VREF	<b>AP</b>	Voltage reference input for ADC
98					NC
99	52		AVDD	<b>AP</b>	Power supply for internal analog circuit
100			PD.0	<b>I/O</b>	General purpose digital I/O pin
			UART1_RXD	<b>I</b>	UART1 Data receiver input pin
			SPI2_SS0	<b>I/O</b>	SPI2 1 <sup>st</sup> slave select pin
			SC1_CLK	<b>O</b>	SmartCard1 clock pin(SC1_UART_TXD)
			AD8	<b>AI</b>	ADC analog input8
101			PD.1	<b>I/O</b>	General purpose digital I/O pin

Pin No.			Pin Name	Pin Type	Description
LQFP 128-pin	LQFP 64-pin	LQFP 48-pin			
			TX1	<b>O</b>	UART1 Data transmitter output pin
			SPI2_CLK	<b>I/O</b>	SPI2 serial clock pin
			SC1_DAT	<b>I/O</b>	SmartCard1 DATA pin(SC1_UART_RXD)
			AD9	<b>AI</b>	ADC analog input9
102			PD.2	<b>I/O</b>	General purpose digital I/O pin
			UART1_RTSn	<b>O</b>	UART1 Request to Send output pin
			I2S_LRCLK	<b>I/O</b>	I <sup>2</sup> S left right channel clock
			SPI2_MISO0	<b>I/O</b>	SPI2 1 <sup>st</sup> MISO (Master In, Slave Out) pin
			SC1_PWR	<b>O</b>	SmartCard1 Power pin
			AD10	<b>AI</b>	ADC analog input10
103			PD.3	<b>I/O</b>	General purpose digital I/O pin
			UART1_CTSn	<b>I</b>	UART1 Clear to Send input pin
			I2S_BCLK	<b>I/O</b>	I <sup>2</sup> S bit clock pin
			SPI2_MOSI0	<b>I/O</b>	SPI2 1 <sup>st</sup> MOSI (Master Out, Slave In) pin
			SC1_RST	<b>O</b>	SmartCard1 RST pin
			AD11	<b>AI</b>	ADC analog input11
104					NC
105			PD.4	<b>I/O</b>	General purpose digital I/O pin
			I2S_DI	<b>I</b>	I <sup>2</sup> S data input
			SPI2_MISO1	<b>I/O</b>	SPI2 2 <sup>nd</sup> MISO (Master In, Slave Out) pin
			SC1_CD	<b>I</b>	SmartCard1 card detect
			LCD_SEG35	<b>AO</b>	LCD segment output 35 at LQFP128
106			PD.5	<b>I/O</b>	General purpose digital I/O pin
			I2S_DO	<b>O</b>	I <sup>2</sup> S data output
			SPI2_MOSI1	<b>I/O</b>	SPI2 2 <sup>nd</sup> MOSI (Master Out, Slave In) pin
			LCD_SEG34	<b>AO</b>	LCD segment output 34 at LQFP128
107	53		PC.7	<b>I/O</b>	General purpose digital I/O pin
			DA1_OUT	<b>AO</b>	DAC 1 output
			EBI_AD5	<b>I/O</b>	EBI Address/Data bus bit5
			TC1	<b>I</b>	Timer1 capture input

Pin No.			Pin Name	Pin Type	Description
LQFP 128-pin	LQFP 64-pin	LQFP 48-pin			
			PWM0_CH1	O	PWM1 Channel1 output
			LCD_SEG17*	AO	LCD segment output 17 at LQFP64
108	54		PC.6	I/O	General purpose digital I/O pin
			DA0_OUT	I	DAC0 output
			EBI_AD4	I/O	EBI Address/Data bus bit4
			TC0	I	Timer0 capture input
			SC1_CD		SmartCard1 card detect pin
			PWM0_CH0	O	PWM0 Channel0 output
109	55		PC.15	I/O	General purpose digital I/O pin
			EBI_AD3	I/O	EBI Address/Data bus bit3
			TC0	I	Timer0 capture input
			PWM1_CH2	O	PWM1 Channel1 output
			LCD_SEG16	AO	LCD segment output 16 at LQFP64
			LCD_SEG33	AO	LCD segment output 33 at LQFP128
110	56		PC.14	I/O	General purpose digital I/O pin
			EBI_AD2	I/O	EBI Address/Data bus bit2
			PWM1_CH3	I/O	PWM1 Channel3 output
			LCD_SEG15	AO	LCD segment output 15 at LQFP64
			LCD_SEG32	AO	LCD segment output 32 at LQFP128
111	57		PB.15	I/O	General purpose digital I/O pin
			INT1	I	External interrupt1 input pin
			SNOOPER	I	Snooper pin
			SC1_CD	I	SmartCard1 card detect
			LCD_SEG14	AO	LCD segment output 14 at LQFP64
			LCD_SEG31	AO	LCD segment output 31 at LQFP128
112					NC
113	58		XT1_IN	O	External 4~24 MHz crystal output pin
			PF.3	I/O	General purpose digital I/O pin
114	59		XT1_OUT	I	External 4~24 MHz crystal input pin
			PF.2	I/O	General purpose digital I/O pin

Pin No.			Pin Name	Pin Type	Description
LQFP 128-pin	LQFP 64-pin	LQFP 48-pin			
115					NC
116	60		nRESET	I	External reset input: Low active, set this pin low reset chip to initial state. With internal pull-up.
117	61		VSS	P	Ground
118			VSS	P	Ground
119					NC
120	62		VDD	P	Power supply for I/O ports and LDO source for internal PLL and digital circuit
121					NC
122			PF.4	I/O	General purpose digital I/O pin
			I2C0_SDA	I/O	I <sup>2</sup> C0 data I/O pin
123			PF.5	I/O	Digital GPI/O pin
			I2C0_SCL	I/O	I <sup>2</sup> C0 clock pin
124			VSS	P	Ground
125	63		PVSS	I/O	PLL Ground
126	64		PB.8	I/O	General purpose digital I/O pin
			STADC	I	ADC external trigger input.
			TM0	I	Timer0 external counter input
			INT0	I	External interrupt0 input pin
			SC2_PWR	O	SmartCard2 Power pin
			LCD_SEG13	AO	LCD segment output 13 at LQFP64
			LCD_SEG30	AO	LCD segment output 30 at LQFP128
127			PE.15	I/O	General purpose digital I/O pin
			LCD_SEG29	O	LCD segment output 29 at LQFP128
128			PE.14	I/O	General purpose digital I/O pin
			LCD_SEG28	O	LCD segment output 28 at LQFP128

**Note:**

1. Pin Type: I=Digital Input, O=Digital Output; AI=Analog Input; AO=Analog Output; P=Power Pin; AP=Analog Power
2. \* : Output voltage for ADC/LCD shared pins cannot be higher than VDD because these pins are without 5V tolerance.



4 BLOCK DIAGRAM

4.1 Nano100 Block Diagram

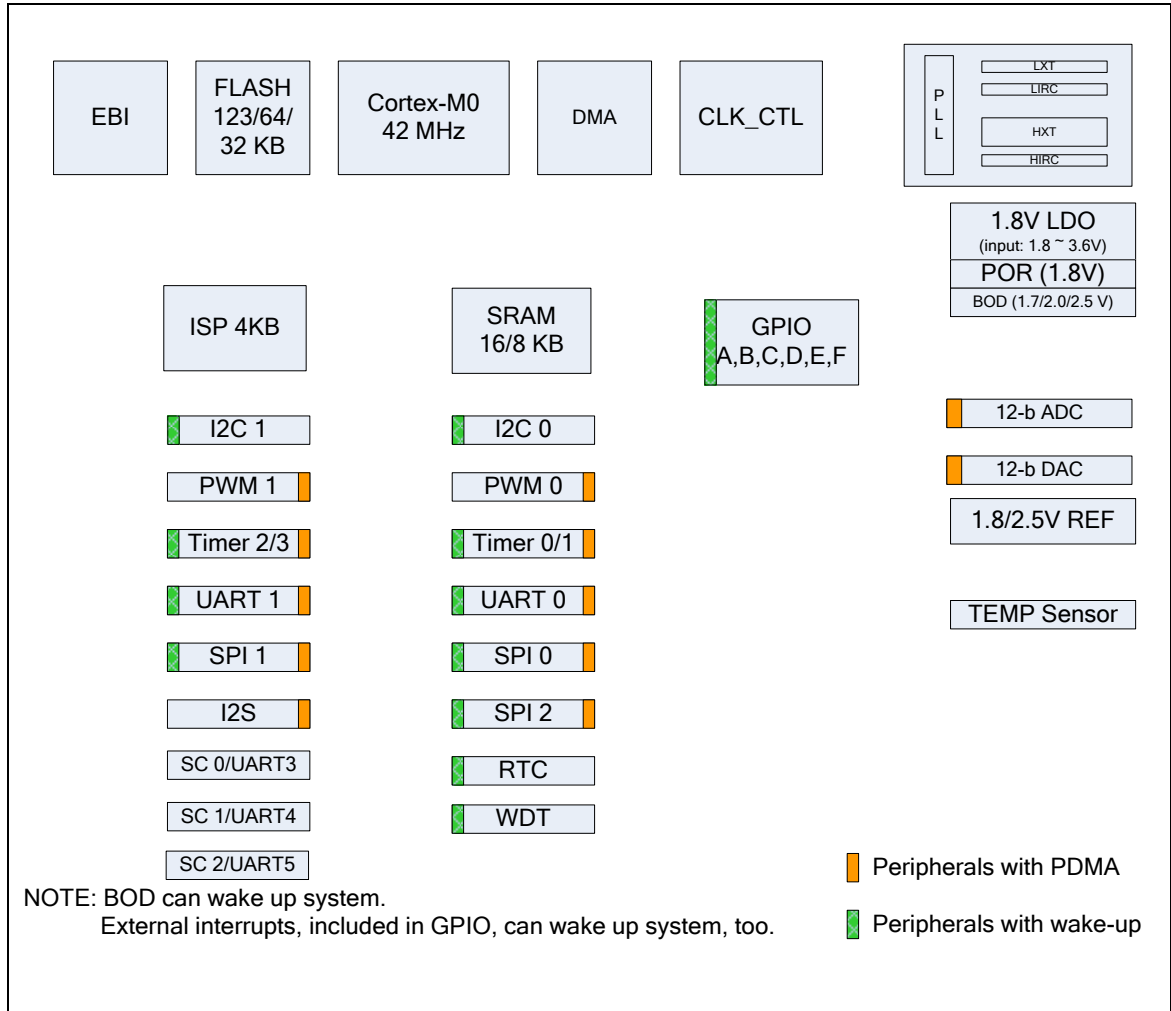

Figure 4-1 NuMicro® Nano100 Block Diagram

4.2 Nano110 Block Diagram

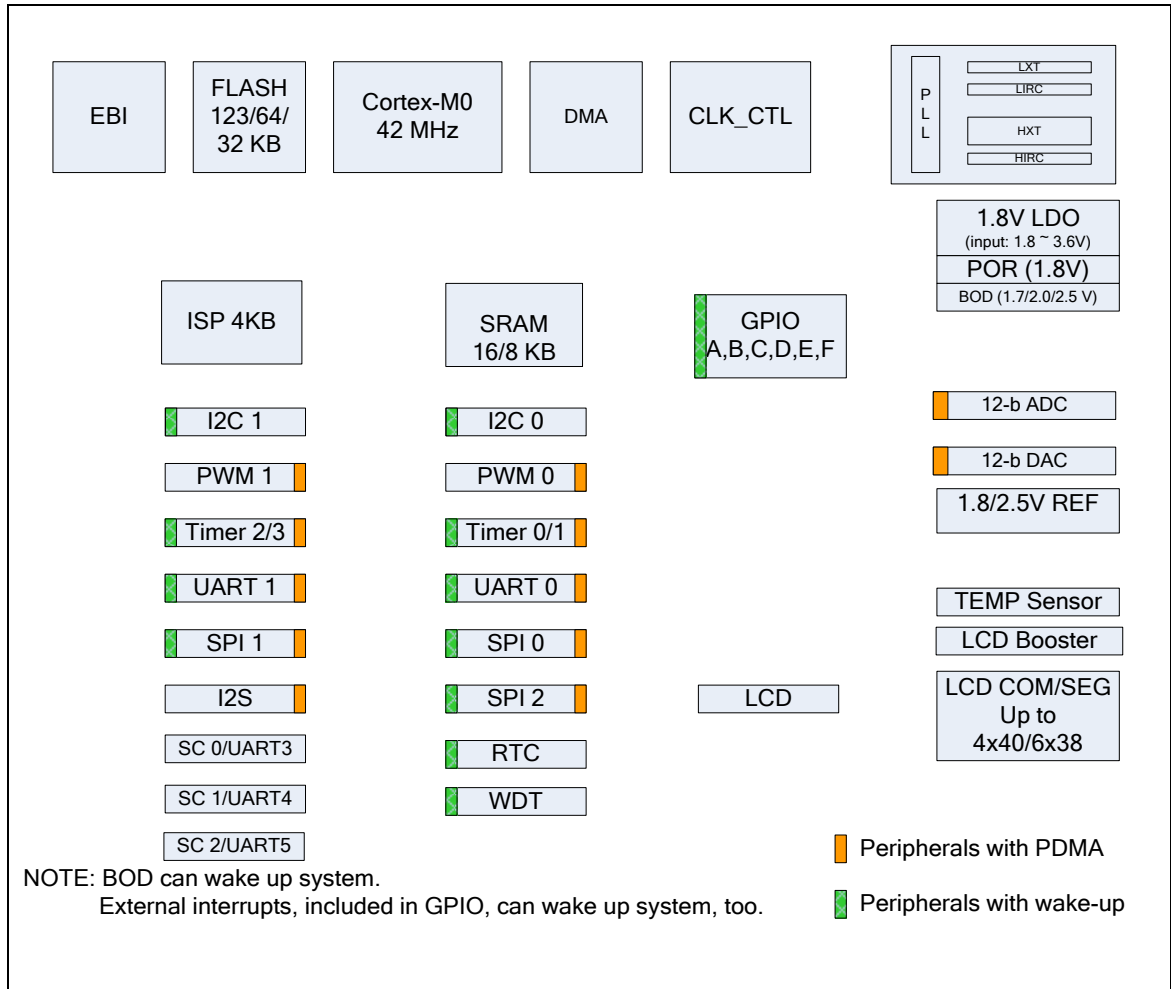

Figure 4-2 NuMicro® Nano110 Block Diagram

4.3 Nano120 Block Diagram

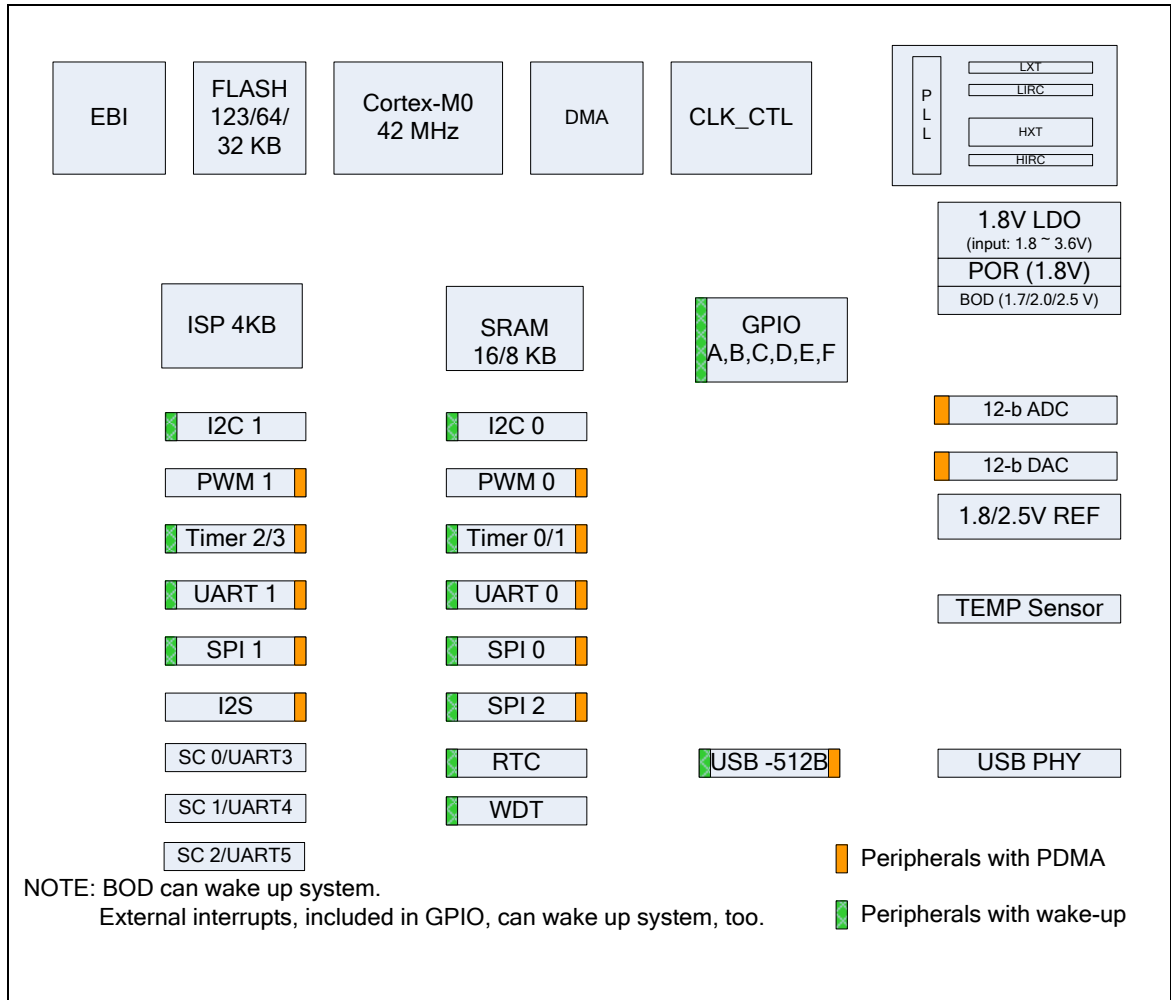

Figure 4-3 NuMicro® Nano120 Block Diagram

4.4 Nano130 Block Diagram

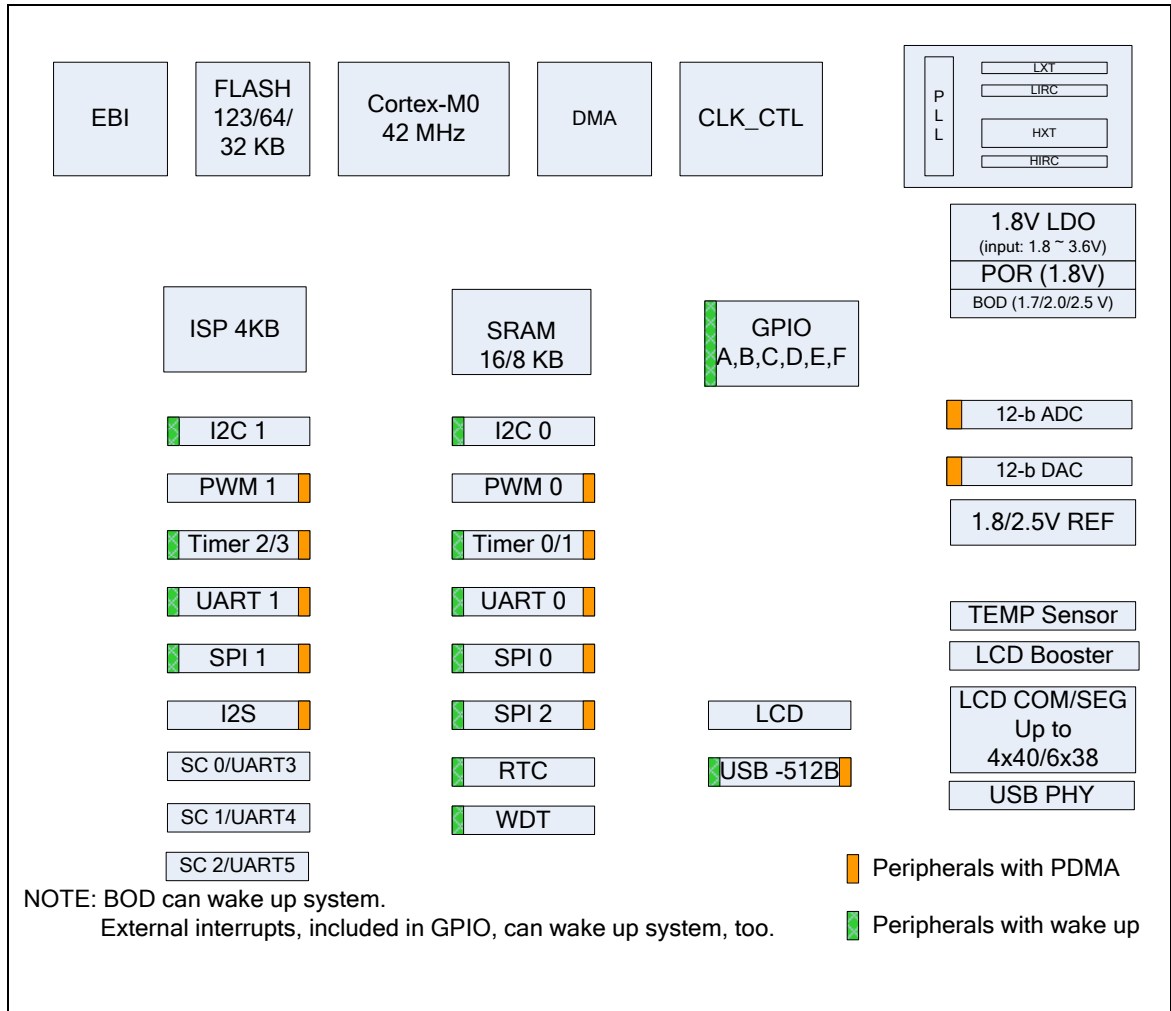

Figure 4-4 NuMicro® Nano130 Block Diagram

## 5 FUNCTIONAL DESCRIPTION

### 5.1 Memory Organization

#### 5.1.1 Overview

The Nano100 provides 4G-byte addressing space. The memory locations assigned to each on-chip modules are shown in following. The detailed register definition, memory space, and programming detailed will be described in the following sections for each on-chip module. The Nano100 series only supports little-endian data format.

#### 5.1.2 Memory Map

The memory locations assigned to each on-chip controllers are shown in the following table.

Address Space	Token	Modules
<b>Flash &amp; SRAM Memory Space</b>		
0x0000_0000 – 0x0001_FFFF	FLASH_BA	FLASH Memory Space (128KB)
0x2000_0000 – 0x2000_3FFF	SRAM_BA	SRAM Memory Space (16KB)
0x6000_0000 --- 0x6001_FFFF	EXTMEM_BA	External Memory Space(128KB)
<b>AHB Modules Space (0x5000_0000 – 0x501F_FFFF)</b>		
0x5000_0000 – 0x5000_01FF	GCR_BA	System Management Control Registers
0x5000_0200 – 0x5000_02FF	CLK_BA	Clock Control Registers
0x5000_0300 – 0x5000_03FF	INT_BA	Interrupt Multiplexer Control Registers
0x5000_4000 – 0x5000_7FFF	GPIO_BA	GPIO Control Registers
0x5000_8000 – 0x5000_BFFF	DMA_BA	DMA Control Registers
0x5000_C000 – 0x5000_FFFF	FMC_BA	Flash Memory Control Registers
0x5001_0000 – 0x5001_03FF	EBI_BA	External Bus Interface Control Registers
<b>APB1 Modules Space (0x4000_0000 ~ 0x400F_FFFF)</b>		
0x4000_4000 – 0x4000_7FFF	WDT_BA	Watchdog Timer Control Registers
0x4000_8000 – 0x4000_BFFF	RTC_BA	Real Time Clock (RTC) Control Register
0x4001_0000 – 0x4001_3FFF	TMR01_BA	Timer0 and Timer1 Control Registers
0x4002_0000 – 0x4002_3FFF	I2C0_BA	I <sup>2</sup> C0 Interface Control Registers
0x4003_0000 – 0x4003_3FFF	SPI0_BA	SPI0 with Master/Slave function Control Registers
0x4004_0000 – 0x4004_3FFF	PWM0_BA	PWM0 Control Registers
0x4005_0000 – 0x4005_3FFF	UART0_BA	UART0 Control Registers
0x4006_0000 – 0x4006_3FFF	USBD_BA	USB FS device Controller Registers
0x400A_0000 – 0x400A_3FFF	DAC_BA	Digital-Analog-Converter (DAC) Control Registers
0x400B_0000 – 0x400B_3FFF	LCD_BA	LCD Control Registers
0x400D_0000 – 0x400D_3FFF	SPI2_BA	SPI2 with Master/Slave function Control Registers

0x400E_0000 – 0x400E_3FFF	ADC12_BA	12-bit Analog-Digital-Converter (ADC12) Control Registers
<b>APB2 Modules Space (0x4010_0000 ~ 0x401F_FFFF)</b>		
0x4011_0000 – 0x4011_3FFF	TMR23_BA	Timer2 and Timer3 Control Registers
0x4012_0000 – 0x4012_3FFF	I2C1_BA	I <sup>2</sup> C1 Interface Control Registers
0x4013_0000 – 0x4013_3FFF	SPI1_BA	SPI1 with Master/Slave function Control Registers
0x4014_0000 – 0x4014_3FFF	PWM1_BA	PWM1 Control Registers
0x4015_0000 – 0x4015_3FFF	UART1_BA	UART1 Control Registers
0x4019_0000 – 0x4019_3FFF	SC0_BA	SmartCard0 Control Registers
0x401A_0000 – 0x401A_3FFF	I2S_BA	I <sup>2</sup> S Control Registers
0x401B_0000 – 0x401B_3FFF	SC1_BA	SmartCard1 Control Registers
0x401C_0000 – 0x401C_3FFF	SC2_BA	SmartCard2 Control Registers
<b>System Control Space (0xE000_E000 ~ 0xE000_EFFF)</b>		
0xE000_E010 – 0xE000_E0FF	SCS_BA	System Timer Control Registers
0xE000_E100 – 0xE000_ECFF	SCS_BA	External Interrupt Controller Control Registers
0xE000_ED00 – 0xE000_ED8F	SCS_BA	System Control Registers

## 5.2 Nested Vectored Interrupt Controller (NVIC)

### 5.2.1 Overview

The Cortex-M0 provides an interrupt controller as an integral part of the exception mode, named as “Nested Vectored Interrupt Controller (NVIC)”. It is closely coupled to the processor kernel and provides following features:

### 5.2.2 Features

- Nested and Vectored interrupt support
- Automatic processor state saving and restoration
- Dynamic priority changing
- Reduced and deterministic interrupt latency

The NVIC prioritizes and handles all supported exceptions. All exceptions are handled in “Handler Mode”. This NVIC architecture supports 32 (IRQ[31:0]) discrete interrupts with 4 levels of priority. All of the interrupts and most of the system exceptions can be configured to different priority levels. When an interrupt occurs, the NVIC will compare the priority of the new interrupt to the current running one’s priority. If the priority of the new interrupt is higher than the current one, the new interrupt handler will override the current handler.

When any interrupts is accepted, the starting address of the interrupt service routine (ISR) is fetched from a vector table in memory. There is no need to determine which interrupt is accepted and branch to the starting address of the correlated ISR by software. While the starting address is fetched, NVIC will also automatically save processor state including the registers “PC, PSR, LR, R0~R3, R12” to the stack. At the end of the ISR, the NVIC will restore the mentioned registers from stack and resume the normal execution. Thus it will take less and deterministic time to process the interrupt request.

The NVIC supports “Tail Chaining” which handles back-to-back interrupts efficiently without the overhead of states saving and restoration and therefore reduces delay time in switching to pending ISR at the end of current ISR. The NVIC also supports “Late Arrival” which improves the efficiency of concurrent ISRs. When a higher priority interrupt request occurs before the current ISR starts to execute (at the stage of state saving and starting address fetching), the NVIC will give priority to the higher one without delay penalty. Thus it advances the real-time capability.

For more detailed information, please refer to the “ARM® Cortex™-M0 Technical Reference Manual” and “ARM® v6-M Architecture Reference Manual”.

## 5.3 System Manager

### 5.3.1 Overview

System manager mainly controls the power modes, wake-up source, system resets and system memory map. It also provides information about product ID, chip reset, IP reset, and multi-function pin control.

### 5.3.2 Features

- Power modes and wake-up sources
- System resets
- System Memory Map
- System manager registers for :
  - ◆ Product ID
  - ◆ Chip and IP reset
  - ◆ Multi-functional pin control



## 5.4 Clock Controller

### 5.4.1 Overview

The clock controller generates clocks for the whole chip, including system clocks (CPU clock, HCLKx, and PCLKx) and all peripheral engine clocks. HCLKx means AHB bus clock for peripherals on AHB bus. PCLKx means APB bus clock for peripherals on APB bus. The clock controller also implements the power control function with the individually clock ON/OFF control, clock source selection and a 4-bit clock divider. The chip will not enter power-down mode until CPU sets the power down enable bit (PD\_EN) and CPU executes the WFI instruction. In the Power-down mode, clock controller turns off the external high frequency crystal, internal high frequency oscillator, and system clocks (CPU clock, HCLKx, and PCLKx) to reduce the power consumption to minimum.

### 5.4.2 Features

- Generates clocks for system clocks and all peripheral engine clocks.
- Each peripheral engine clock can be turned on/off.
- High frequency crystal, internal high frequency oscillator, and system clocks will be turned off when chip is in Power-down mode.

## 5.5 Analog to Digital Converter (ADC)

### 5.5.1 Overview

This chip contains one 12-bit successive approximation analog-to-digital converter (SAR A/D converter) with 12 external input channels and 6 internal channels. The A/D converter supports three operation modes: Single, Single-cycle Scan and Continuous Scan mode, and can be started by software and external STADC/PB.8 pin and timer event start.

Note that the I/O pins used as ADC analog input pins must be configured as input type and off digital function (GPIOA\_OFFD) should be turned on before ADC function is enabled.

### 5.5.2 Features

- Analog input voltage range: 0~Vref (Max to 3.6V)
- Selectable 12-bits, 10-bits, 8-bits and 6-bits resolution
- Supports sampling time settings (in ADC\_CLK unit) for channel 0~11 individually and channel 12~17 share the same one sampling time setting
- Supports two power-down modes:
  - ◆ Power-down mode
  - ◆ Standby mode
- Up to 12 external analog input channels (channel0 ~ channel11), and 6 internal channels (channel12~channel17) converting six voltage sources, including DAC0, DAC1, internal band-gap voltage, internal temperature sensor output, AVDD, and AVSS.
- Maximum ADC clock frequency is 42 MHz and each conversion is 19 clocks+ sampling time depending on the input resistance.
- Three operating modes
  - ◆ Single mode: A/D conversion is performed one time on a specified channel.
  - ◆ Single-cycle Scan mode: A/D conversion is performed one cycle on all specified channels with the sequence from the lowest numbered channel to the highest numbered channel.
  - ◆ Continuous Scan mode: A/D converter continuously performs Single-cycle scan mode until software stops A/D conversion.
- An A/D conversion can be started by:
  - ◆ Software write 1 to ADST bit
  - ◆ External pin STADC
  - ◆ Selects one from four timer events (TMR0, TMR1, TMR2 and TMR3) that enable ADC and transfer AD results by PDMA
- Conversion results held in data registers for each channel
- Conversion result can be compared with a specified value and user can select whether to generate an interrupt when conversion result is equal to the compare register setting.
- Supports Calibration and load Calibration words capability.

## 5.6 Digital to Analog Converter (DAC)

### 5.6.1 Overview

DAC is a 12-bit voltage-output digital-to-analog converter. Two DACs are implemented in this chip.

### 5.6.2 Features

DAC is a 12-bit voltage-output DAC. DAC can use in conjunction with the PDMA controller. When two DACs are present, they may be grouped together for synchronous update operation.

Features:

- Int\_VREF or VREF or AVDD reference voltage selection
- Synchronized update capability for two DACs
- DAC maximum conversion rate is 500 KSPS

## 5.7 DMA Controller

### 5.7.1 Overview

The DMA controller contains six channel peripheral direct memory access (PDMA) controllers, a video direct memory access (VDMA) controller and a cyclic redundancy check (CRC) generator. The PDMA controller can transfer data to and from memory or transfer data to and from APB devices. The DMA has eight channels of DMA including one channel VDMA (Memory-to-Memory) and six channels PDMA (Peripheral-to-Memory or Memory-to-Peripheral or Memory-to-Memory) and a CRC controller. For channel0 VDMA, it supports block transfer from memory to memory. For PDMA channel (DMA CH1~CH6), there is one-word buffer as transfer buffer between the Peripherals APB devices and Memory. And for channel 0 VDMA, there is a two-word buffer.

Software can stop the DMA operation by disable PDMA [PDMACEN]/VDMA [VDMACEN]. Software can recognize the completion of a DMA operation by software polling or when it receives an internal DMA interrupt. The DMA controller can increase source or destination address, fixed or wrap around them as well.

The DMA controller also contains a cyclic redundancy check (CRC) generator that can perform CRC calculation with programmable polynomial settings. The CRC engine support CPU PIO mode and DMA transfer mode.

### 5.7.2 Features

Seven DMA channels and a CRC generator: 1 VDMA channel and 6 PDMA channels. Each channel can support a unidirectional transfer.

AMBA AHB master/slave interface compatible, for data transfer and register read/write.

Hardware round robin priority scheme.

- VDMA
  - ◆ Memory-to-memory transfer
  - ◆ Supports block transfer with stride
  - ◆ Supports word/half-word/byte boundary address
  - ◆ Supports address direction: increment and decrement
- PDMA
  - ◆ Peripheral-to-memory, memory-to-peripheral, and memory-to-memory transfer
  - ◆ Supports word boundary address
  - ◆ Supports word alignment transfer length in memory-to-memory mode
  - ◆ Supports word/half-word/byte alignment transfer length in peripheral-to-memory and memory-to-peripheral mode
  - ◆ Supports word/half-word/byte transfer data width from/to peripheral
  - ◆ Supports address direction: increment, fixed, and wrap around
- Cyclic Redundancy Check (CRC)
  - ◆ Supports four common polynomials CRC-CCITT, CRC-8, CRC-16, and CRC-32
    - CRC-CCITT:  $X^{16} + X^{12} + X^5 + 1$
    - CRC-8:  $X^8 + X^2 + X + 1$
    - CRC-16:  $X^{16} + X^{15} + X^2 + 1$
    - CRC-32:  $X^{32} + X^{26} + X^{23} + X^{22} + X^{16} + X^{12} + X^{11} + X^{10} + X^8 + X^7 + X^5 + X^4 + X^2 + X + 1$

- ◆ Programmable seed value
- ◆ Supports programmable order reverse setting for input data and CRC checksum
- ◆ Supports programmable 1's complement setting for input data and CRC checksum
- ◆ Supports CPU PIO mode or DMA transfer mode
- ◆ Supports 8/16/32-bit of data width in CPU PIO mode
  - 8-bit write mode: 1-AHB clock cycle operation
  - 16-bit write mode: 2-AHB clock cycle operation
  - 32-bit write mode: 4-AHB clock cycle operation
- ◆ Supports byte alignment transfer length in CRC DMA mode

## 5.8 External Bus Interface

### 5.8.1 Overview

This chip is equipped with an external bus interface (EBI) to access external device. To save the connections between external device and this chip, EBI support address bus and data bus multiplex mode. Also, address latch enable (ALE) signal is used to differentiate the address and data cycle.

### 5.8.2 Features

- External devices with max. 64 Kbytes size (8-bit data width)/128 Kbytes (16-bit data width) supported
- Supports variable external bus base clock (MCLK)
- Supports 8-bit or 16-bit data width
- Supports variable data access time (tACC), address latch enable time (tALE) and address hold time (tAHD)
- Address bus and data bus multiplex mode supported to save the address pins
- Configurable idle cycle supported for different access condition: Write command finish (W2X), Read-to-Read (R2R), Read-to-Write (R2W)
- Supports PDMA and VDMA transfer

## 5.9 FLASH Memory Controller (FMC)

### 5.9.1 Overview

This chip is equipped with 32K/64K/123K bytes on-chip embedded Flash EPROM for application program memory (APROM) that can be updated through ISP/IAP procedure. In System Programming (ISP) function enables user to update program memory when chip is soldered on PCB. After chip powered on Cortex-M0 CPU fetches code from APROM or LDROM decided by boot select (CBS) in Config0. By the way, this chip also provides DATA Flash Region, the data flash is shared with original program memory and its start address is configurable and defined by user in Config1. The data flash size is defined by user application request.

### 5.9.2 Features

- AHB interface compatible
- Run up to 42 MHz with zero wait state for discontinuous address read access
- 32/64/123KB application program memory (APROM)
- 4KB in system programming (ISP) loader program memory (LDROM)
- Programmable data flash start address and memory size with 512 bytes page erase unit
- In System Program (ISP)/In Application Program (IAP) to update on chip Flash EPROM

## 5.10 General Purpose I/O Controller

### 5.10.1 Overview

Up to 86 General Purpose I/O pins can be shared with other function pins; it depends on the chip configuration. These 86 pins are arranged in 6 ports named with GPIOA, GPIOB, GPIOC, GPIOD, GPIOE and GPIOF. Ports A ~ E have the maximum of 16 pins while port F have 6 pins. Each one of the 86 pins is independent and has the corresponding register bits to control the pin mode function and data.

The I/O type of each of I/O pins can be independently software configured as input, output, and open-drain mode. Each I/O pin has a very weak individual pull-up resistor which is about 110 K $\Omega$ ~300 K $\Omega$  for VDD from 1.8 V to 3.6 V.

### 5.10.2 Features

- Up to 86 general purpose I/O pins
- Supports Input, Output, Open-drain Operation mode
- Programmable de-bounce timing
- Each I/O pin can be programmed as either edge-trigger or level-sensitive
- Each I/O pin can be programmed as either low-level active or high-level active
- Each I/O pin can be programmed as either falling-edge trigger or rising-edge trigger



## 5.11 I<sup>2</sup>C

### 5.11.1 Overview

I<sup>2</sup>C is a two-wire, bi-directional serial bus that provides a simple and efficient method of data exchange between devices. The I<sup>2</sup>C standard is a true multi-master bus including collision detection and arbitration that prevents data corruption if two or more masters attempt to control the bus simultaneously. Serial, 8-bit oriented bi-directional data transfers can be made up to 1.0 Mbps.

Data is transferred between a Master and a Slave synchronously to SCL on the SDA line on a byte-by-byte basis. Each data byte is 8-bit long. There is one SCL clock pulse for each data bit with the MSB being transmitted first. An acknowledge bit follows each transferred byte.

A transition on the SDA line while SCL is high is interpreted as a command (START or STOP). Each bit is sampled during the high period of SCL; therefore, the SDA line may be changed only during the low period of SCL and must be held stable during the high period of SCL.

The controller's on-chip I<sup>2</sup>C logic provides the serial interface that meets the I<sup>2</sup>C bus standard mode specification. The I<sup>2</sup>C controller handles byte transfers autonomously. Pull up resistor is needed for I<sup>2</sup>C operation as these are open drain pins.

The I<sup>2</sup>C controller is equipped with two slave address registers. The contents of the registers are irrelevant when I<sup>2</sup>C is in Master mode. In the Slave mode, the seven most significant bits must be loaded with the user's own slave address. The I<sup>2</sup>C hardware will react if the contents of I2CADDR are matched with the received slave address.

This controller supports the "General Call (GC)" function. If the GC bit is set this controller will respond to General Call address (00H). Clear GC bit to disable general call function. When GC bit is set and the I<sup>2</sup>C is in Slave mode, it can receive the general call address which is equal to 00H after master sends general call address to the I<sup>2</sup>C bus, then it will follow status of GC mode. If it is in Master mode, the ACK bit must be cleared when it sends general call address of 00H to the I<sup>2</sup>C bus.

The I<sup>2</sup>C-bus controller supports multiple address recognition with two address mask register. When the bit in the address mask register is set to one, it means the received corresponding address bit is don't-care. If the bit is set to zero, that means the received corresponding register bit should be exact the same as address register.

### 5.11.2 Features

- Acts as Master or Slave mode
- Bidirectional data transfer between masters and slaves
- Multi-master bus (no central master)
- Arbitration between simultaneously transmitting masters without corruption of serial data on the bus
- Serial clock synchronization allows devices with different bit rates to communicate via one serial bus
- Serial clock synchronization can be used as a handshake mechanism to suspend and resume serial transfer
- One built-in 14-bit time-out counter requesting the I<sup>2</sup>C interrupt if the I<sup>2</sup>C bus hangs up and timer-out counter overflows.
- Programmable clock divider allows versatile rate control
- Supports 7-bit addressing mode
- Supports multiple address recognition ( Two slave addresses with mask option)
- Supports Power-down wake-up function

## 5.12 I<sup>2</sup>S

### 5.12.1 Overview

The audio controller consists of I<sup>2</sup>S protocol to interface with external audio CODEC. Two 8 word deep FIFO for receiving path and transmitting path respectively and is capable of handling 8 ~ 32 bit word sizes. PDMA controller handles the data movement between FIFO and memory.

### 5.12.2 Features

- I<sup>2</sup>S can operate as either master or Slave mode.
- Capable of handling 8, 16, 24 and 32 bits word sizes.
- Mono and stereo of audio data are supported.
- I<sup>2</sup>S and MSB justified data format are supported.
- Two FIFO data buffers (each 32 bits) are provided, one is for transmitting and the other is for receiving.
- Generate interrupt when buffer levels cross a programmable boundary.
- Two PDMA channels request, one is for transmitting and the other is for receiving.

## 5.13 LCD Display Driver

### 5.13.1 Overview

The LCD driver can directly drive a LCD glass by creating the ac segment and common voltage signals automatically. It can support static, 1/2 duty, 1/3 duty, 1/4 duty, 1/5 duty and 1/6 duty LCD glass with up to 38 segments with 6 COM (segment 0 is used as LCD\_COM4 and segment 1 is used as LCD\_COM5) or 40 segments with 4 COM (LCD\_COM0 ~ LCD\_COM3).

A built-in charge pump function can be enabled to provide the LCD glass with higher voltage than the system voltage. The LCD driver would generate voltage higher than the threshold voltage in order to darken a segment and a voltage lower than threshold to make a segment clear. However, the LCD display segment will degrade if the applied voltage has a DC-component. To avoid this, the generated waveform by LCD driver are arranged such that average voltage of each segment is zero and the RMS(root-mean-square) voltage applied on a LCD segment lower than the segment threshold making LCD clear and RMS voltage higher than the segment threshold making LCD dark.

Note : Output voltage for ADC/LCD shared pins cannot be higher than VDD because these pins are without 5V tolerance.

(LQFP64 : LCD\_SEG17, LCD\_SEG19, LCD\_SEG20, LCD\_SEG21, LCD\_SEG22, LCD\_SEG23)

(LQFP128 : LCD\_SEG36, LCD\_SEG37, LCD\_SEG38, LCD\_SEG39)

### 5.13.2 Features

- Supports up to 174 dots (6x29) or 124 dots (4x31) in LQFP64 package and 228 dots (6x38) or 160 dots (4x40) in LQFP100/LQFP128 package Segment/Com pins:
- Common 0-5 multiplexing functions with GPI/O pins
- Segment 0-39 multiplexing function with GPI/O pins
- Supports Static, 1/2 bias and 1/3 bias voltage
- Six display modes: Static, 1/2 duty, 1/3 duty, 1/4 duty, 1/5 duty or 1/6 duty Selectable LCD frequency by frequency divider
- Configurable frame frequency
- Internal Charge pump, adjustable contrast adjustment
- Embedded LCD bias reference ladder (R-Type, 200kΩ resistors)
- Configurable Charge pump frequency
- Blinking capability
- Supports R/C-type method
- LCD frame interrupt

## 5.14 Pulse Width Modulation (PWM)

### 5.14.1 Overview

This chip has two PWM controllers, each controller has 4 independent PWM outputs, CH0~CH3, or as 2 complementary PWM pairs, (CH0, CH1), (CH2, CH3) with 2 programmable dead-zone generators.

Each two PWM outputs, (CH0, CH1), (CH2, CH3), share the same 8-bit prescaler, clock divider providing 5 divided frequencies (1, 1/2, 1/4, 1/8, 1/16). Each PWM output has independent 16-bit PWM down-count counter for PWM period control, and 16-bit comparators for PWM duty control. Each dead-zone generator has two outputs. The first dead-zone generator output is CH0 and CH1, and for the second dead-zone generator, the output is CH2 and CH3. The 2 sets of PWM controller total provide eight independent PWM interrupt flags which are set by hardware when the corresponding PWM period down counter reaches zero. PWM interrupt will be asserted when both PWM interrupt source and its corresponding enable bit are active. Each PWM output can be configured as one-shot mode to produce only one PWM cycle signal or continuous mode to output PWM waveform continuously.

When DZEN01 of PWMx\_CTL is set, CH0 and CH1 perform complementary PWM paired function; the paired PWM timing, period, duty and dead-time are determined by PWM channel 0 timer and Dead-zone generator 0. Similarly, When DZEN23 of PWMx\_CTL is set the complementary PWM pair of (CH2, CH3) is controlled by PWM channel 2.

To prevent PWM driving output pin with unsteady waveform, the 16-bit period down counter and 16-bit comparator are implemented with double buffer. When user writes data to counter/comparator buffer registers the updated value will be loaded into the 16-bit down counter/comparator at the time down counter reaching zero. The double buffering feature avoids glitch at PWM outputs.

When the 16-bit period down counter reaches zero, the interrupt request is generated. If PWM output is set as continuous mode, when the down counter reaches zero, it is reloaded with CN of PWMx\_DUTYy(y=0~3) Register automatically then start decreases, repeatedly. If the PWM output is set as one-shot mode, the down counter will stop and generate one interrupt request when it reaches zero.

The value of PWM counter comparator is used for pulse width modulation. The counter control logic changes the output level when down-counter value matches the value of compare register.

The alternate feature of the PWM is digital input capture function. If capture function is enabled the PWM output pin is switched as capture input pin. The capture channel 0 and PWM CH0 share one timer; and the capture channel 1 and PWM CH1 share one timer, and etc. Therefore user must setup the PWM timer before enabling capture feature. After capture feature is enabled, the capture always latches PWM timer to Capture Rising Latch Register (PWMx\_CRLy) where y=0~3, when input channel has a rising transition and latches PWM timer to Capture Falling Latch Register (PWMx\_CFLy) where y=0~3, when input channel has a falling transition. Capture channel 0 interrupt is programmable by setting PWMx\_CAPINTEN. Whenever Capture event latched for channel 0/1/2/3, the PWM timer 0/1/2/3 will be reload at this moment if the corresponding reload enable bit specified in CAPCTL are set.

The maximum captured frequency that PWM can capture is dominated by the capture interrupt latency. When capture interrupt occurs, software will do at least three steps, they are: Read PWMINTSTS to tell it from interrupt source and Read PWMx\_CRLy/PWMx\_CFLy(y=0~3) to get capture value and finally write 1 to clear PWMx\_INTSTS. If interrupt latency will take time T0 to finish, the capture signal mustn't transient during this interval. In this case, the maximum capture frequency will be 1/T0.

## 5.14.2 Features

### 5.14.2.1 PWM Function:

- Two PWM controllers, each controller having 4 independent PWM outputs, CH0~CH3, or as 2 complementary PWM pairs, (CH0, CH1), (CH2, CH3) with 2 programmable dead-zone generators
- Up to 8 PWM channels or 4 PWM paired channels
- Up to 16 bits PWM counter width
- PWM Interrupt request synchronous with PWM period
- Single-shot or Continuous mode
- Four Dead-Zone generators

### 5.14.2.2 Capture Function:

- Timing control logic shared with PWM timer.
- 8 Capture input channels shared with 8 PWM output channels.
- Each channel supports one rising latch register (PWMx\_CRLy), one falling latch register (PWMx\_CFLy) and Capture interrupt flag (CAPIFy) where x=0~1,y=0~3.
- Eight 16-bit counters for eight capture channels or four 32-bit counter for four capture channels when cascade is enabled: when CH01CASKEN is set, the original 16-bit counter of channel 1 will combine with channel 0's 16 bit counter for channel 0 input capture counting and so does CH23CASKEN for channel 2, 3
- Supports PDMA transfer function for PWMx channel 0, 2

## 5.15 RTC

### 5.15.1 Overview

Real Time Clock (RTC) unit provides user the real time and calendar message. The Clock Source of RTC is from an external 32.768 kHz crystal connected at pins X32I and X32O (reference to pin Description) or from an external 32.768 kHz oscillator output fed at pin X32I. The RTC unit provides the time message (second, minute, hour) in Time Loading Register (TLR) as well as calendar message (day, month, year) in Calendar Loading Register (CLR). The data message is expressed in BCD format. This unit offers alarm function that user can preset the alarm time in Time Alarm Register (TAR) and alarm calendar in Calendar Alarm Register (CAR).

The RTC unit supports periodic Time Tick and Alarm Match interrupts. The periodic interrupt has 8 period options 1/128, 1/64, 1/32, 1/16, 1/8, 1/4, 1/2 and 1 second which are selected by TTR (TTR[2:0]). When RTC counter in TLR and CLR is equal to alarm setting time registers TAR and CAR, the alarm interrupt status (RIIR.AIS) is set and the alarm interrupt is requested if the alarm interrupt is enabled (RIER.AIER=1). The RTC Time Tick (if wake-up CPU function is enabled, RTC\_TTR[TWKE] high) and Alarm Match can cause CPU wake-up from idle or Power-down mode.

### 5.15.2 Features

- One time counter (second, minute, hour) and calendar counter (day, month, year) for user to check the time
- Alarm register (second, minute, hour, day, month, year)
- 12-hour or 24-hour mode is selectable
- Leap year compensation automatically
- Day of week counter
- Frequency compensate register (FCR)
- All time and calendar message is expressed in BCD code
- Supports periodic time tick interrupt with 8 period options 1/128, 1/64, 1/32, 1/16, 1/8, 1/4, 1/2 and 1 second
- Supports RTC Time Tick and Alarm Match interrupt
- Supports wake-up CPU from Power-down mode
- Supports 80 bytes spare registers and a snoop pin to clear the content of these spare registers

## 5.16 Smart Card Host Interface (SC)

### 5.16.1 Overview

The Smart Card Interface controller (SC controller) is based on ISO/IEC 7816-3 standard and fully compliant with PC/SC Specifications. It also provides status of card insertion/removal.

### 5.16.2 Features

- ISO-7816-3 T = 0, T = 1 compliant
- EMV2000 compliant
- Supports up to three ISO-7816-3 ports
- Separates receive / transmit 4 byte entry buffer for data payloads
- Programmable transmission clock frequency

- Programmable receiver buffer trigger level
- Programmable guard time selection (11 ETU ~ 266 ETU)
- A 24-bit and two 8-bit counters for Answer to Reset (ATR) and waiting times processing
- Supports auto inverse convention function
- Supports stop clock level and clock stop (clock keep) function
- Supports transmitter and receiver error retry and error number limitation function
- Supports hardware activation sequence process
- Supports hardware warm reset sequence process
- Supports hardware deactivation sequence process
- Supports hardware auto deactivation sequence when detected the card removal.
- Support UART mode
  - ◆ Half duplex, asynchronous communications
  - ◆ Separate receiving / transmitting 4 bytes entry FIFO for data payloads
  - ◆ Support programmable baud rate generator for each channel
  - ◆ Support programmable receiver buffer trigger level
  - ◆ Programmable transmitting data delay time between the last stop bit leaving the TX-FIFO and the de-assertion by setting SCx\_EGTR [EGT] register
  - ◆ Programmable even, odd or no parity bit generation and detection
  - ◆ Programmable stop bit, 1 or 2 stop bit generation



## 5.17 SPI

### 5.17.1 Overview

The Serial Peripheral Interface (SPI) is a synchronous serial data communication protocol. Devices communicate in Master/Slave mode with 4-wire bi-direction interface. It is used to perform a serial-to-parallel conversion on data received from a peripheral device, and a parallel-to-serial conversion on data transmitted to a peripheral device. The SPI controller can be configured as a master or a slave device.

The SPI controller supports wake-up function. When this chip stays in power-down mode, it can be waked up chip by off-chip device.

This controller supports variable serial clock function for special application and 2-bit transfer mode to connect 2 off-chip slave devices at the same time. The SPI controller also supports PDMA function to access the data buffer.

### 5.17.2 Features

- Supports Master (max. 32 MHz) or Slave (max. 16 MHz) mode operation
- Supports 1 bit and 2 bit transfer mode
- Support Dual IO transfer mode
- Configurable bit length of a transaction from 8 to 32-bit
- Supports MSB first or LSB first transfer sequence
- Two slave select lines supported in Master mode
- Configurable byte or word suspend mode
- Supports byte re-ordering function
- Supports variable serial clock in Master mode
- Provide separate 8-level depth transmit and receive FIFO buffer
- Supports wake-up function
- Supports PDMA transfer
- Supports three wires, no slave select signal, bi-direction interface

## 5.18 Timer Controller

### 5.18.1 Overview

This chip is equipped with four timer modules including TIMER0, TIMER1, TIMER2 and TIMER3 (TIMER0/1 is at APB1 and TIMER2/3 is at APB2), which allow user to easily implement a counting scheme or timing control for applications. The timer can perform functions like frequency measurement, event counting, interval measurement, clock generation, delay timing, and so on. The timer can generate an interrupt signal upon timeout, or provide the current value of count during operation.

### 5.18.2 Features

- Independent Clock Source for each Timer (TMRx\_CLK, x= 0, 1,2,3)
- Time-out period = (Period of timer clock input) \* (8-bit pre-scale counter + 1) \* (24-bit TCMP)
- Counting cycle time =  $(1 / \text{TMRx\_CLK}) * (2^8) * (2^{24})$
- Internal 8-bit pre-scale counter
- Internal 24-bit up counter is readable through TDR (Timer Data Register)
- Supports One-shot, Periodic, Output Toggle and Continuous Counting Operation mode
- Supports external pin capture for interval measurement
- Supports external pin capture for timer counter reset
- Supports Inter-Timer trigger
- Supports Internal trigger event to ADC, DAC and PDMA

## 5.19 UART Controller

### 5.19.1 Overview

The UART controllers provides up to two channels of Universal Asynchronous Receiver/Transmitter (UART) modules that are UART0 and UART1. (UART0 is at APB1 and UART1 is at APB2).

The Universal Asynchronous Receiver/Transmitter (UART) performs a serial-to-parallel conversion on data received from the peripheral, and a parallel-to-serial conversion on data transmitted from the CPU. The UART controller also supports IrDA (SIR) function mode, LIN Master/Slave function mode and RS-485 function mode. Each UART channel supports nine types of interrupts including receiver threshold level reaching interrupt (INT\_RDA), transmitter FIFO empty interrupt (INT\_THRE), line status interrupt (break error, parity error, framing error or RS-485 interrupt) (INT\_RLS), time-out interrupt (INT\_TOUT), MODEM status interrupt (INT\_MODEM), Buffer error interrupt (INT\_BUF\_ERR), wake-up interrupt (INT\_WAKE), auto-baud rate detect or auto-baud rate counter overflow flag (INT\_ABAUD) and LIN function interrupt (INT\_LIN).

The UART0 and UART1 are built-in with a 16-byte transmitter FIFO (TX\_FIFO) and a 16-byte receiver FIFO (RX\_FIFO) that reduces the number of interrupts presented to the CPU. The CPU can read the status of the UART at any time during the operation. The reported status information includes the type and condition of the transfer operations being performed by the UART, as well as 3 error conditions (parity error, framing error or break interrupt) occur while receiving data. The UART controller supports auto-baud rate detection. The auto-baud rate detection controls the process of measuring the incoming clock/data rate for the baud rate generation and can be read and written at user discretion. The UART controller also support incoming data or CTSn wake-up function. When the system is in power-down mode, an incoming data or CTSn signal will wake-up CPU from power-down mode. The UART includes a programmable baud rate generator that is capable of dividing crystal clock input by divisors to produce the clock that transmitter and receiver need. The baud rate equation is  $Baud\ Rate = \frac{UART\_CLK}{[BRD + 1]}$ , where BRD are defined in UART Baud Rate Divider Register (UARTx\_BAUD). Below table lists the equations in the various conditions and the UART baud rate setting table.

DIV_16_EN	BRD	Baud Rate Equation
Disable (Mode 0)	A	$UART\_CLK / (A+1)$ , A must >8
Enable (Mode 1)	A	$UART\_CLK / [16 * (A+1)]$

Table 5-1 UART Baud Rate Equation

System clock =12 MHz		
Baud rate	Mode 0	Mode 1
921600	A=12	Not Supported
460800	A=25	Not Supported
230400	A=51	A=2
115200	A=103	A=6
57600	A=207	A=12
38400	A=311	A=19

19200	A=624	A=38
9600	A=1249	A=77
4800	A=2499	A=155

Table 5-2 UART Baud Rate Setting

5.19.1.1 Auto-Flow Control

The UART0 and UART1 controllers support auto-flow control function that uses two low-level signals, CTSn (clear-to-send) and RTSn (request-to-send) to control the flow of data transfer between the UART and external devices (ex: Modem). When auto-flow is enabled, the UART is not allowed to receive data until the UART asserts RTSn (RTSn high) to external device. When the number of bytes in the RX-FIFO equals the value of UART\_TLCTL [RTS\_TRI\_LEV], the RTSn is de-asserted. The UART sends data out when UART controller detects CTSn is asserted (CTSn high) from external device. If a valid asserted CTSn is not detected the UART controller will not send data out.

5.19.1.2 Auto-Baud Rate Detection

The UART0 and UART1 controllers support auto-baud rate detection. The auto-baud rate function can be used to measure the receiver incoming data baud rate. If enabled the auto-baud feature, UART controller will measure the bit time of the received data stream and set the divisor latch registers UART\_BARD. Auto-baud rate detection is started by setting the UART\_CTL [ABAUD\_EN].

5.19.1.3 UART Wake-Up Function

The UART0 and UART1 controllers support wake-up system function. The wake-up function includes CTSn wake-up function (UART\_CTL [WAKE\_CTS\_EN]) and data wake-up function (UART\_CTL [WAKE\_DATA\_EN]). When the system is operation in power-down mode, the UART can wake-up system by CTSn pin or by incoming data.

5.19.1.4 IrDA Function Mode

The UART controllers also provides Serial IrDA (SIR, Serial Infrared) function (User must set UART\_FUN\_SEL to select IrDA function). The SIR specification defines a short-range infrared asynchronous serial transmission mode with one start bit, 8 data bits, and 1 stop bit. The maximum data rate is 115.2 Kbps (half duplex). The IrDA SIR block contains an IrDA SIR Protocol encoder/decoder. The IrDA SIR protocol is half-duplex only. So it cannot transmit and receive data at the same time. The IrDA SIR physical layer specifies a minimum 10 ms transfer delay between transmission and reception, and in IrDA Operation mode the UART\_BAUD setting must be mode1 (UART\_BAUD [DIV\_16\_EN] = "1").

5.19.1.5 RS-485 Function Mode

Another alternate function of UART controllers is RS-485 9 bit mode function whose direction control can be controlled by RTSn pin or GPIO. The RS-485 function mode is selected by setting the UART\_FUN\_SEL register to select RS-485 function. The RS-485 driver control is implemented by using the RTSn control signal from an asynchronous serial port to enable the RS-485 driver. In RS-485 mode, many characteristics of the RX and TX are same as UART.

5.19.1.6 LIN Function Mode

**5.19.2 The LIN mode is selected by setting the LIN\_EN bit in UART\_FUN\_SEL register. In LIN mode, one start bit and 8-bit data format with 1-bit stop bit are required in accordance with the LIN standard. Features**

- Full duplex, asynchronous communications.

- Separate receiving / transmitting 16 bytes entry FIFO for data payloads.
- Supports hardware auto-flow control/flow control function (CTS<sub>n</sub>, RTS<sub>n</sub>) and programmable (CTS<sub>n</sub>, RTS<sub>n</sub>) flow control trigger level.
- Supports programmable baud rate generator for each channel.
- Supports auto-baud rate detect function.
- Supports programmable receiver buffer trigger level.
- Supports incoming data or CTS<sub>n</sub> to wake-up function.
- Supports 9 bit receiver buffer time-out detection function.
- All UART channels can be served by the PDMA controller.
- Programmable transmitting data delay time between the last stop bit leaving the TX-FIFO and the de-assertion by setting UART\_TMCTL [DLY] register.
- Supports break error, frame error, parity error and receiving / transmitting buffer overflow detect function.
- Fully programmable serial-interface characteristics:
  - ◆ Programmable number of data bit, 5, 6, 7, 8 character.
  - ◆ Programmable parity bit, even, odd, no parity or stick parity bit generation and detection.
  - ◆ Programmable stop bit, 1, 1.5, or 2 stop bit generation.
- Supports IrDA SIR function mode
  - ◆ Supports 3/16 bit period modulation.
- Supports LIN function mode.
  - ◆ Supports LIN Master/Slave mode
  - ◆ Supports programmable break generation function for transmitter.
  - ◆ Supports break detect function for receiver.
- Supports RS-485 function mode.
  - ◆ Supports RS-485 9bit mode.
  - ◆ Supports hardware or software controls RTS<sub>n</sub> or software control GPIO to control transfer direction.

## 5.20 USB

### 5.20.1 Overview

The USB controller is a USB 2.0 full-speed device controller. It is compliant with USB 2.0 full speed device specification and supports control/bulk/interrupt/isochronous transfer types.

In this device controller, there are two main interfaces: the APB bus and USB bus which comes from the USB PHY transceiver. For the APB bus, the CPU can program control registers through it. There is an internal 512-byte SRAM as data buffer in this controller. For IN token or OUT token transfer, it is necessary to write data to SRAM or read data from SRAM through the APB interface. Users need to allocate the effective starting address of SRAM for each endpoint buffer through “buffer segmentation register (BUFSEG)”.

This device controller contains 8 configurable endpoints. Each endpoint can be configured as IN or OUT endpoint. The function address of the device and endpoint number in each endpoint shall be configured properly in advance for receiving or transmitting a data packet correctly. The transmitting/receiving length in each endpoint is defined in maximum payload register (MXPLD) and the handshakes between Host and Device are also handled by it.

There are four different interrupt events in this controller. They are the wake-up function, device plug-in or plug-out event, USB events, like IN ACK, OUT ACK etc, and BUS events, like suspend and resume, etc. Any event will cause an interrupt, and users just need to check the related event flags in interrupt event status register (USB\_INTSTS) to acknowledge what kind of events occurring, and then check the related USB Endpoint Status Register (USB\_EPSTS) to acknowledge what kind of event occurring in this endpoint.

A software-disable function is also supported for this USB controller. It is used to simulate the disconnection of this device from the host. If user enables the DRVSE0 bit (USB\_CTL[4]), the USB controller will force USB\_DP and USB\_DM to level low and USB device function is disabled (disconnected). After disable the DRVSE0 bit, USB\_DP will be pulled high by internal pull-high circuit then host will enumerate the USB device connection again.

Reference: Universal Serial Bus Specification Revision 2.0

### 5.20.2 Features

This Universal Serial Bus (USB) performs a serial interface with a single connector type for attaching all USB peripherals to the host system. Following is the feature listing of this USB.

- Compliant with USB 2.0 Full-Speed specification.
- Provide 1 interrupt vector with 4 different interrupt events (WAKEUP, FLDET, USB and BUS).
- Supports Control/Bulk/Interrupt/Isochronous transfer type.
- Supports suspend function when no bus activity existing for 3 ms.
- Provide 8 endpoints for configurable Control/Bulk/Interrupt/Isochronous transfer types
- 512-byte SRAM buffer inside
- Provide remote wake-up capability.

## 5.21 Watchdog Timer Controller

### 5.21.1 Overview

The purpose of Watchdog Timer is to perform a system reset after the software running into a problem. This prevents system from hanging for an infinite period of time. Besides, this Watchdog Timer supports the function to wake-up CPU from power-down mode. The watchdog timer includes an 18-bit free running counter with programmable time-out intervals.

### 5.21.2 Features

- 18-bit free running WDT counter for Watchdog timer time-out interval.
- Selectable time-out interval ( $2^4 \sim 2^{18}$ ) and the time-out interval is 104 ms ~ 26.316 s (if WDT\_CLK = 10 kHz).
- Reset period =  $(1 / 10 \text{ kHz}) * 63$ , if WDT\_CLK = 10 kHz.

## 5.22 Window Watchdog Timer Controller

### 5.22.1 Overview

The purpose of Window Watchdog Timer is to perform a system reset within a specified window period to prevent software run to uncontrollable status by any unpredictable condition.

### 5.22.2 Features

- 6-bit down counter and 6-bit compare value to make the window period flexible
- Selectable WWDT clock pre-scale counter to make WWDT time-out interval variable



## 6 ARM® CORTEX™-M0 CORE

### 6.1 Overview

The Cortex™-M0 processor is a configurable, multistage, 32-bit RISC processor. It has an AMBA AHB-Lite interface and includes an NVIC component. It also has optional hardware debug functionality. The processor can execute Thumb code and is compatible with other Cortex-M profile processor. The profile supports two modes – Thread mode and Handler mode. Handler mode is entered as a result of an exception. An exception return can only be issued in Handler mode. Thread mode is entered on Reset, and can be entered as a result of an exception return. The following figure shows the functional controller of processor.

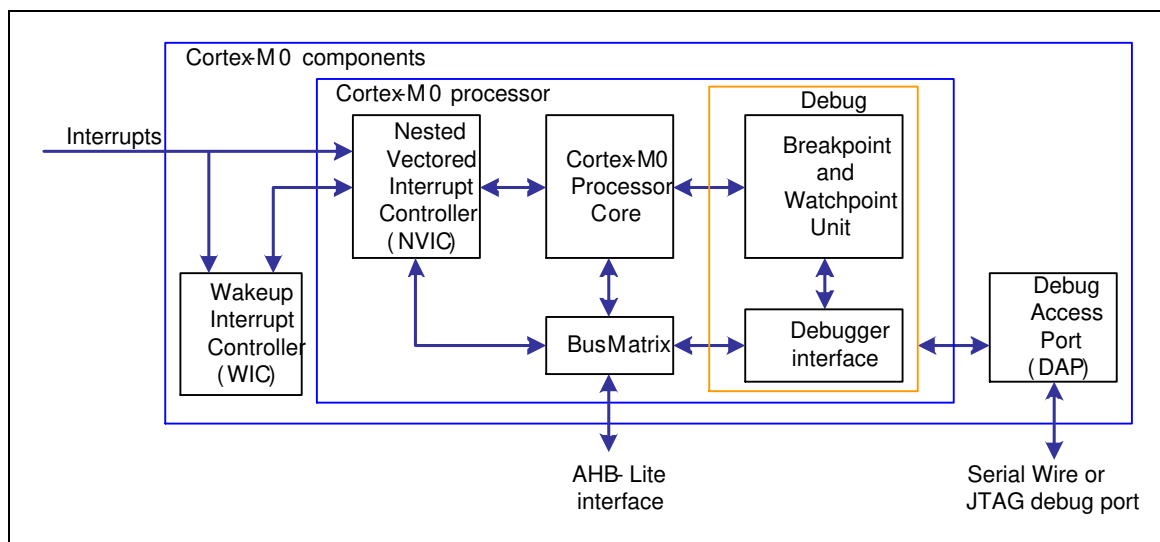

Figure 6-1 M0 Functional Block

### 6.2 Features

- A low gate count processor:
  - ◆ ARMv6-M Thumb® instruction set
  - ◆ Thumb-2 technology
  - ◆ ARMv6-M compliant 24-bit SysTick timer
  - ◆ A 32-bit hardware multiplier
  - ◆ Supports little-endian data accesses
  - ◆ Capable of deterministic, fixed-latency, interrupt handling
  - ◆ Load/store-multiples and multi-cycle-multiplies that can be abandoned and restarted to facilitate rapid interrupt handling
  - ◆ C Application Binary Interface compliant exception model. This is the ARMv6-M, C Application Binary Interface (C-ABI) compliant exception model that enables the use of pure C functions as interrupt handlers
  - ◆ Low Power Sleep mode entry using Wait For Interrupt (WFI), Wait For Event (WFE) instructions, or return from interrupt sleep-on-exit feature
- NVIC:
  - ◆ 32 external interrupt inputs, each with four levels of priority

- ◆ Dedicated Non-Maskable Interrupt (NMI) input
- ◆ Supports for both level-sensitive and pulse-sensitive interrupt lines
- ◆ Wake-up Interrupt Controller (WIC), providing Ultra-low Power Sleep mode support
- Debug support:
  - ◆ Four hardware breakpoints
  - ◆ Two watch points
  - ◆ Program Counter Sampling Register (PCSR) for non-intrusive code profiling
  - ◆ Single step and vector catch capabilities
- Bus interfaces:
  - ◆ Single 32-bit AMBA-3 AHB-Lite system interface providing simple integration to all system peripherals and memory
  - ◆ Single 32-bit slave port that supports the DAP (Debug Access Port)

## 7 APPLICATION CIRCUIT

### 7.1 LCD Charge Pump

#### 7.1.1 C-type 1/3 Bias

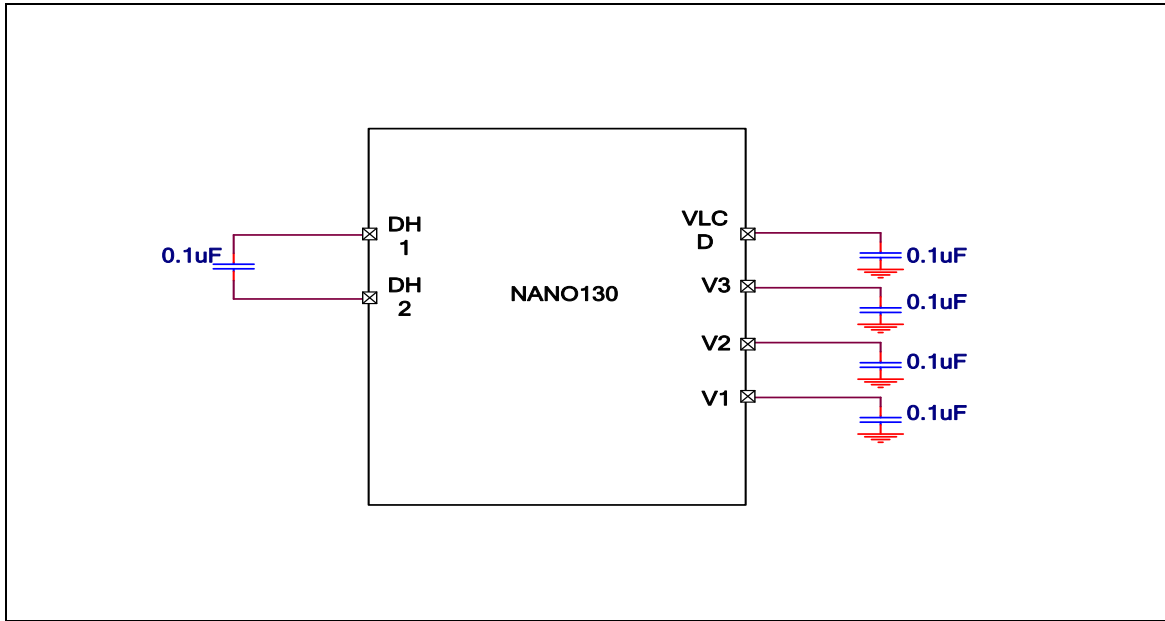

#### 7.1.2 C-type 1/2 Bias

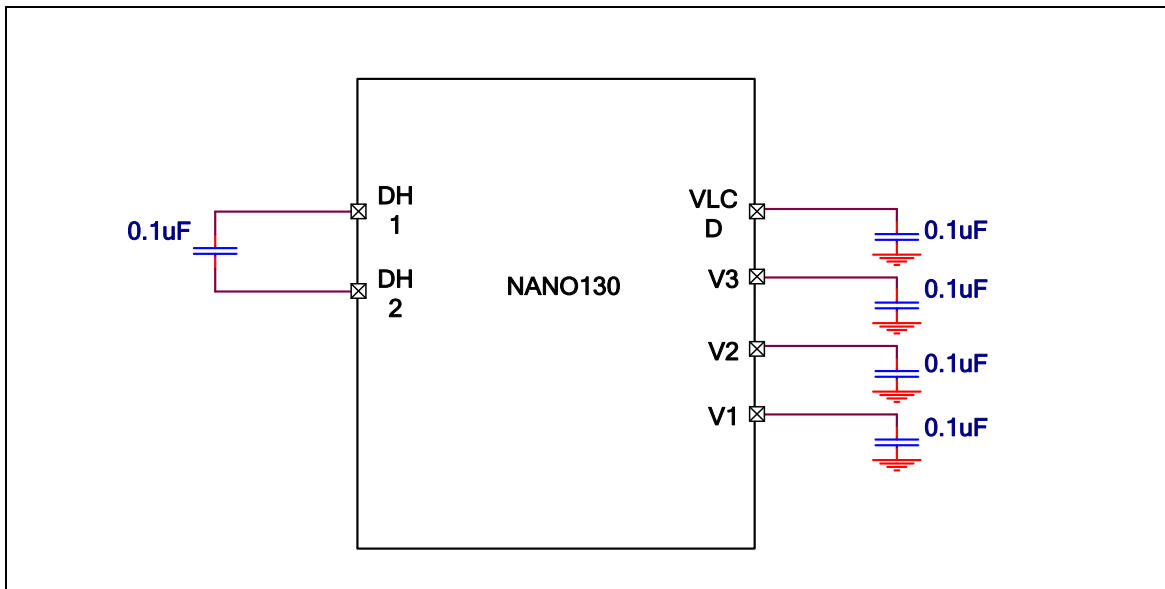

#### 7.1.3 Internal R-type

Nano110/130 series MCUs also support external R-type mode (bypass internal R) to reduce current consumption. For external R-type application, VLCD is normally connected to system VDD, or it can be connected to VDD through an external variable resistor (VR) which is used for adjusting LCD contrast.

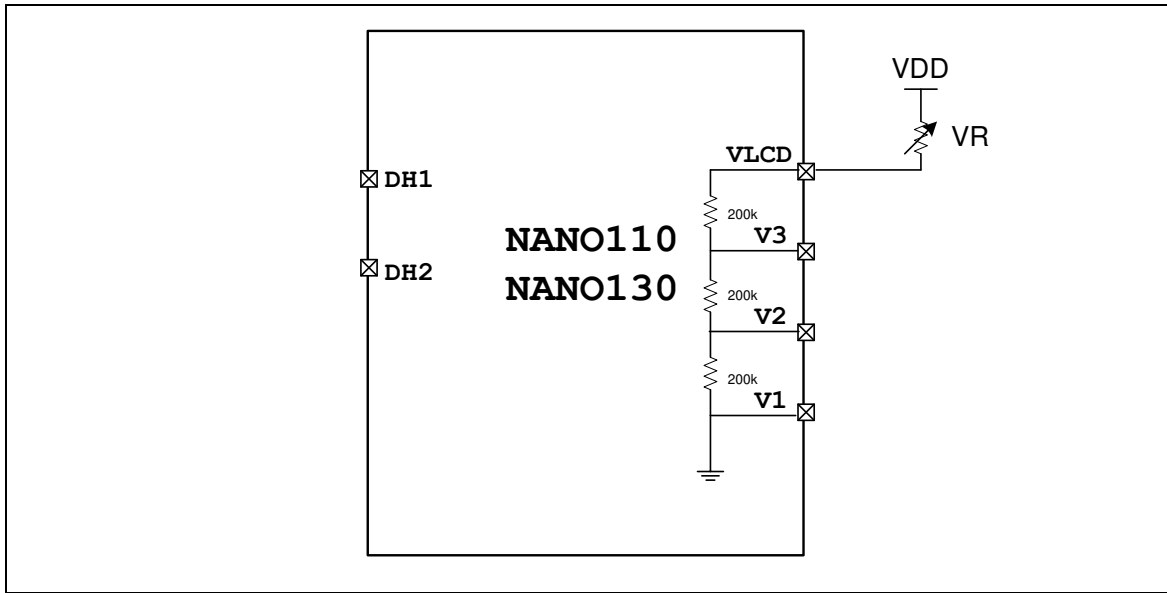

### 7.1.4 External R-type

To reduce the current, the resistor ladder value can be increased. At some point, when the resistor ladder value is increased, the contrast will become affected and the waveform shape will be altered. Therefore, capacitors around 0.1uF should be chosen and place closed to resistor ladder based on the contrast and size of the pixels on the glass.

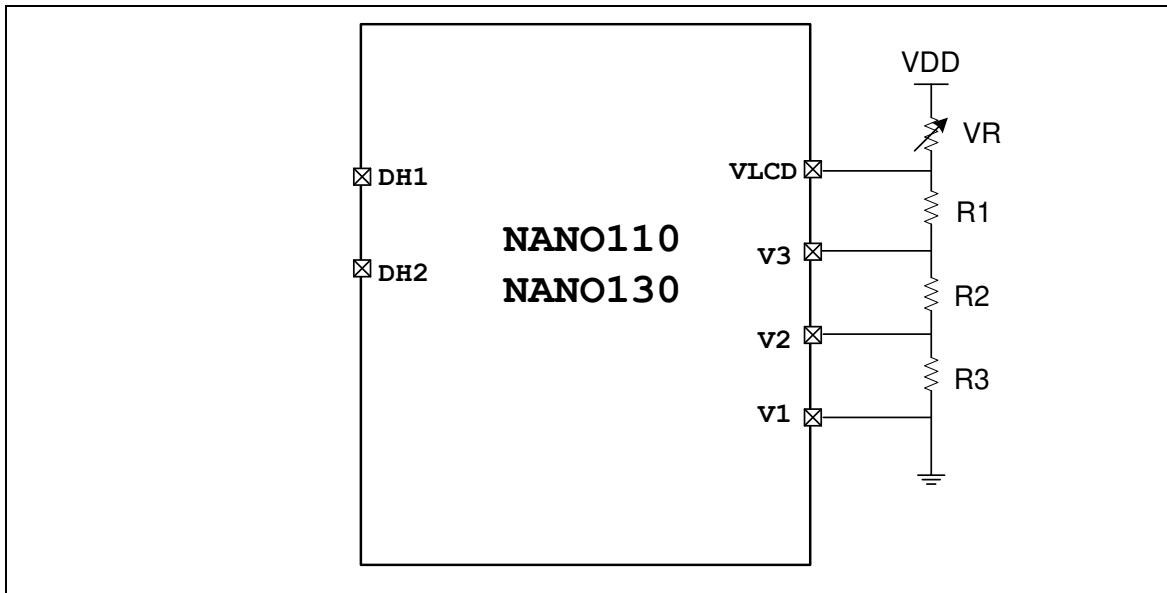

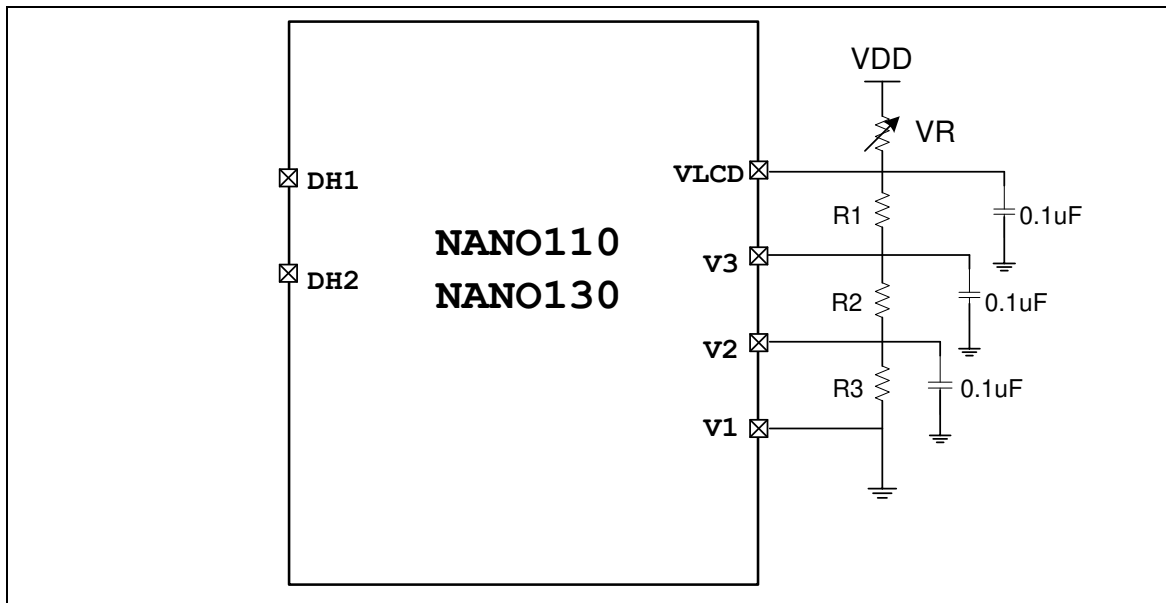

## 7.2 ADC Application Circuit

### 7.2.1 Voltage Reference Source

#### 7.2.1.1 AVDD

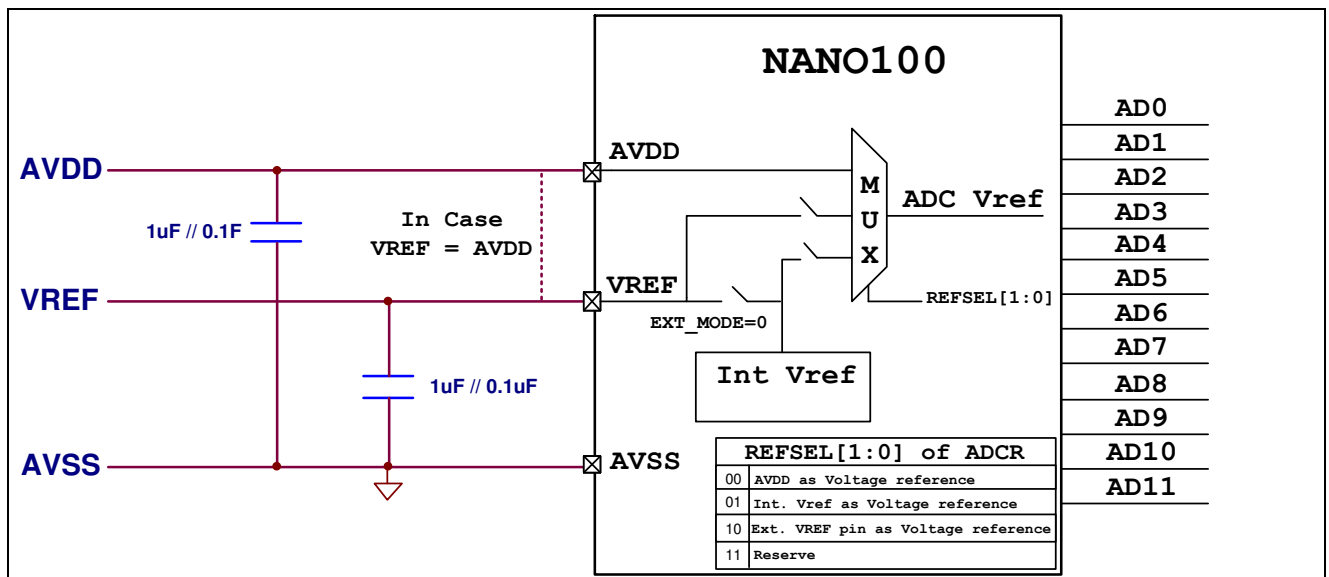

7.2.1.2 Vref Pin

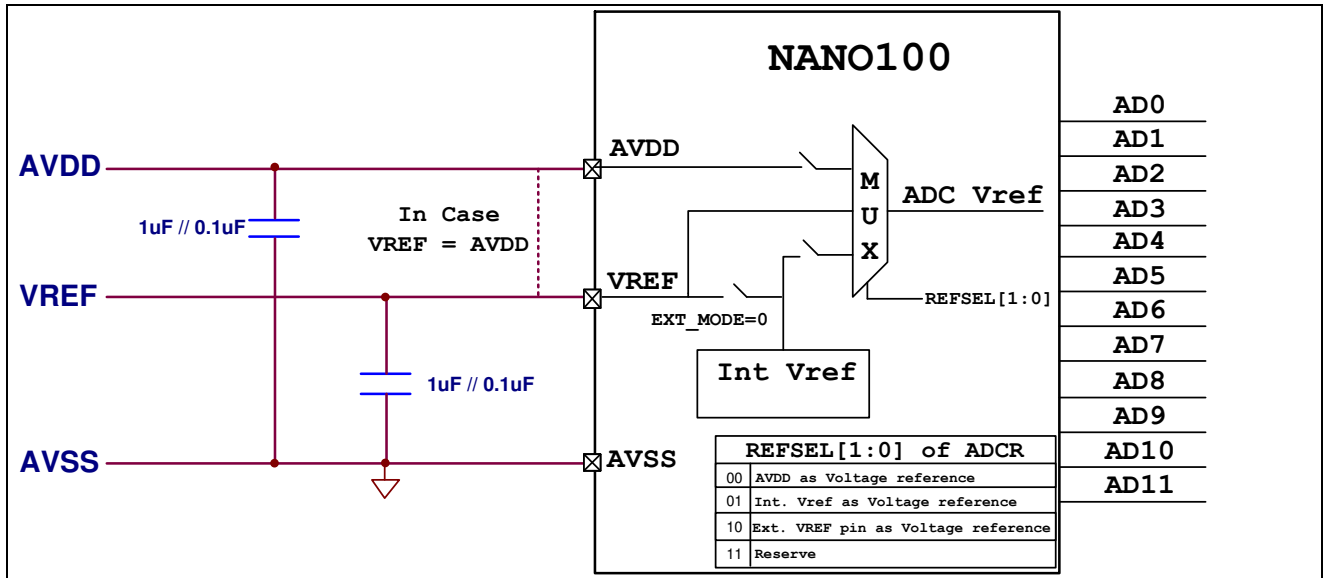

7.2.1.3 Int Vref

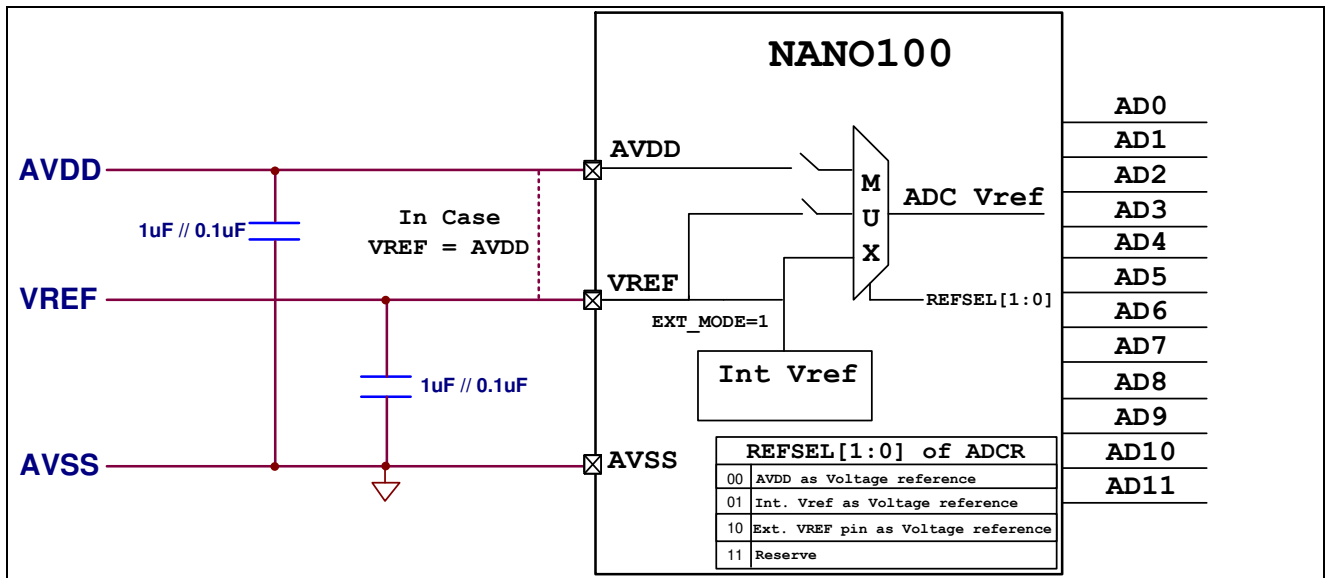

### 7.3 DAC Application Circuit

#### 7.3.1 Voltage Reference Source

##### 7.3.1.1 AVDD

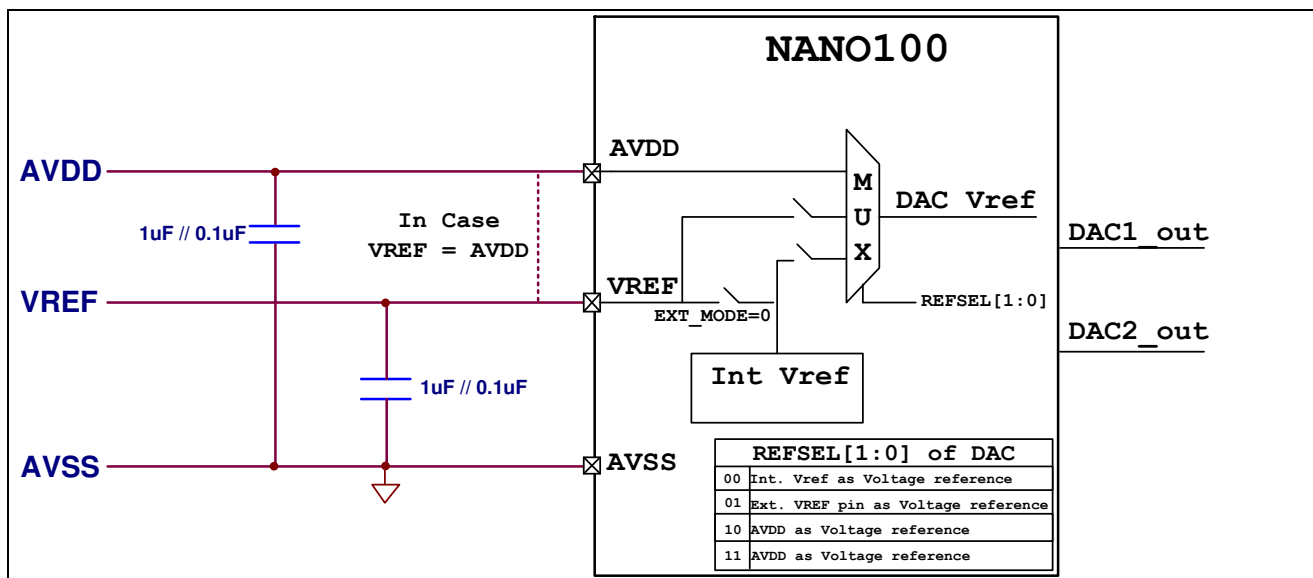

##### 7.3.1.2 Vref Pin

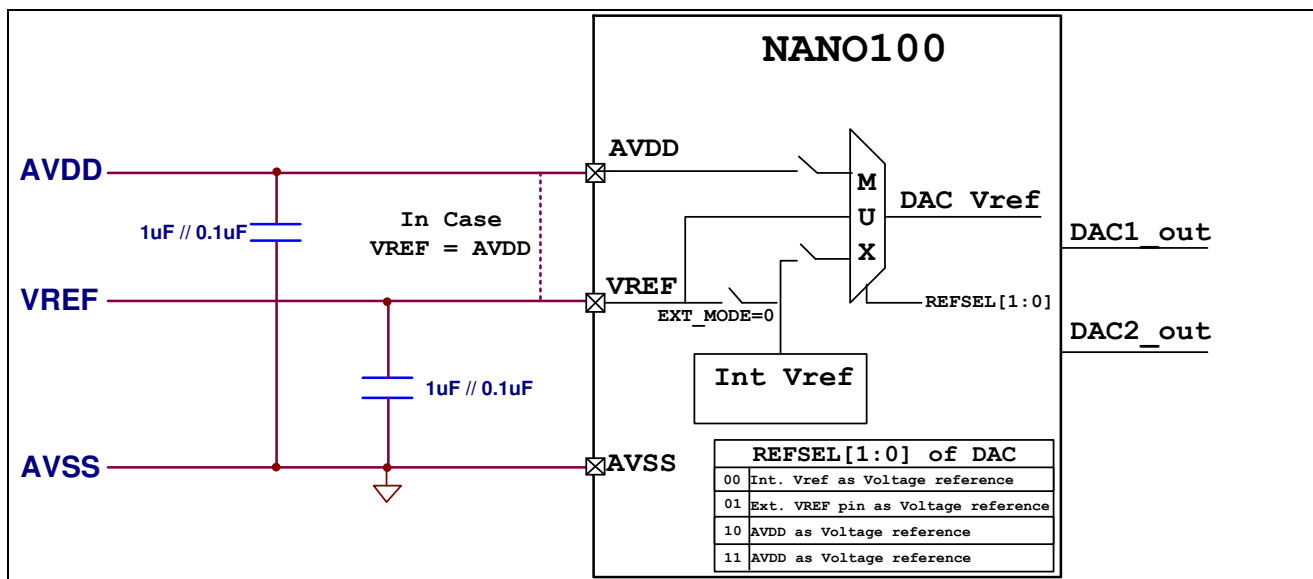

7.3.1.3 Int Vref

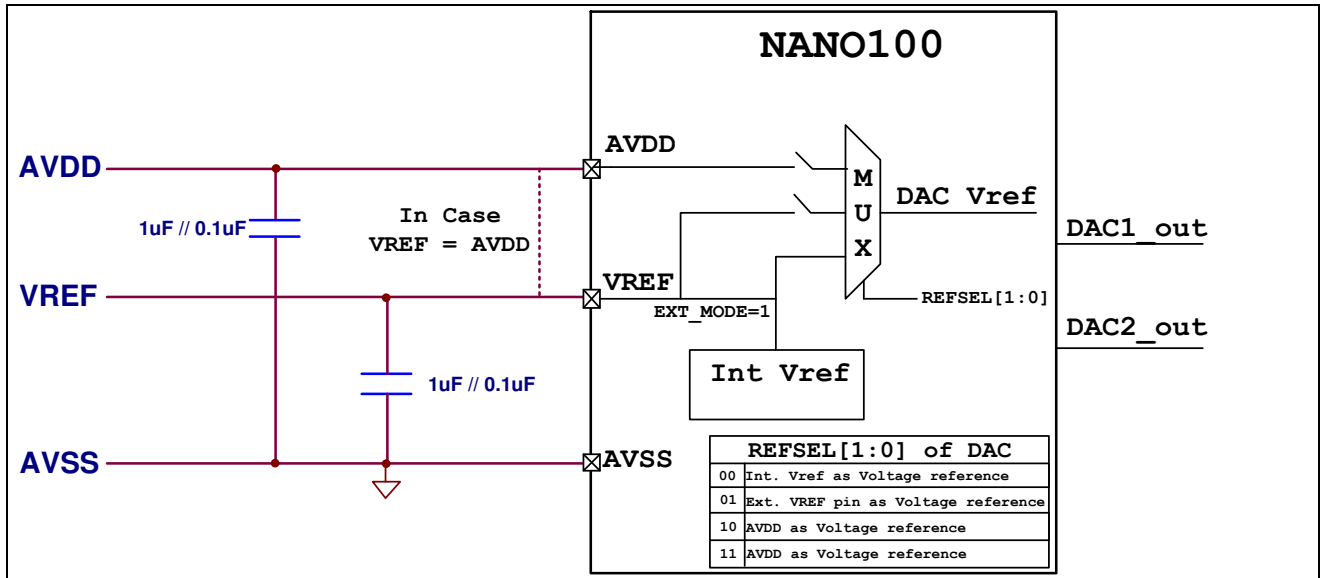



7.4 Whole Chip Application Circuit

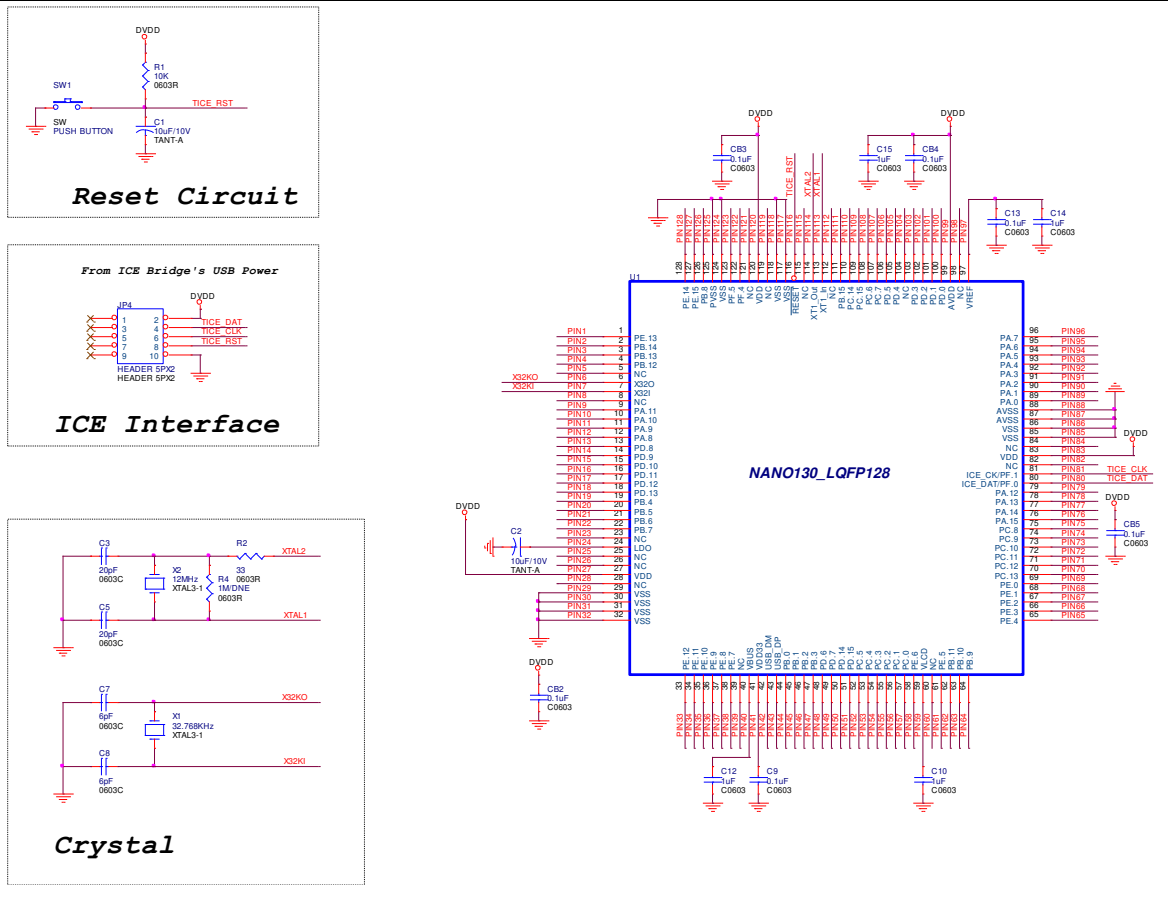

8 POWER COMSUMPTION

Part No	Test Condition	VDD	CPU Clock	Current		
<b>Nano100 (B) series</b> 128 KB Flash 16 KB RAM	<b>Operating Mode:</b> CPU run while(1) in FLASH ROM Clock = 12 MHz Crystal Oscillator Disable all peripheral	3.3V	12 MHz	2.41mA 200uA/MHz		
		1.8V	12 MHz	N/A		
	<b>Idle Mode:</b> CPU stop Clock = 12 MHz Crystal Oscillator Disable all peripheral	3.3V	12 MHz	900uA 75uA/MHz		
		1.8V	12 MHz	N/A		
	<b>RTC + LCD Mode: (RAM retention)</b> (Power down with 32K and LCD enabled) CPU stop Clock = 32.768 kHz Crystal Oscillator Disable all peripheral except RTC and LCD circuit Without panel loading	C-type	3.3V	-	10uA	
					Internal R-type ( With 200kΩ Resistor ladder )	8.5uA
					External R-type ( With 1MΩ Resistor ladder )	4.5uA
		C-type/R-type	1.8V	-	N/A	
	<b>RTC Mode: (RAM retention)</b> (Power down with 32K enabled) CPU stop Clock = 32.768 kHz Crystal Oscillator Disable all peripheral except RTC circuit	3.3V	-	2.5uA		
		1.8V	-	2.0uA		
	<b>Power-down Mode: (RAM retention)</b> CPU and all clocks stop	3.3V	-	1uA		
		1.8V	-	0.8uA		
	<b>Wake-Up from Power-down Mode</b>	3.3V	7us	N/A		

**Note:** Wake-up time: 7us from wake-up event to first CPU core valid clock; 10us from interrupt event to interrupt service routine first instruction.

## 9 ELECTRICAL CHARACTERISTIC

### 9.1 Absolute Maximum Ratings

SYMBOL	PARAMETER	MIN	MAX	UNIT
DC Power Supply	$V_{DD}-V_{SS}$	-0.3	+4.0	V
Input Voltage on 5V Tolerance Pin	$V_{IN}$	$V_{SS} - 0.3$	$V_{DD} + 3.7$	V
Input Voltage on Any Other Pin without 5V Tolerance Pin	$V_{IN}$	$V_{SS} - 0.3$	$V_{DD} + 0.3$	V
Oscillator Frequency	$1/t_{CLCL}$	4	24	MHz
Operating Temperature	$T_A$	-40	+85	°C
Storage Temperature	$T_{ST}$	-55	+150	°C
Maximum Current into VDD		-	150	mA
Maximum Current out of VSS		-	150	mA
Maximum Current sunk by a I/O Pin		-	25	mA
Maximum Current Sourced by a I/O Pin		-	25	mA
Maximum Current Sunk by Total I/O Pins		-	100	mA
Maximum Current Sourced by Total I/O Pins		-	100	mA

**Note :** Output voltage for ADC/LCD shared pins cannot be higher than VDD because these pins are without 5V tolerance.

(LQFP64 : LCD\_SEG17, LCD\_SEG19, LCD\_SEG20, LCD\_SEG21, LCD\_SEG22, LCD\_SEG23)

(LQFP128 : LCD\_SEG36, LCD\_SEG37, LCD\_SEG38, LCD\_SEG39)

### 9.2 Nano100/Nano110/Nano120/Nano130 DC Electrical Characteristics

(VDD-VSS=3.3V, TA = 25°C, FOSC = 32 MHz unless otherwise specified.)

PARAMETER	SYM.	SPECIFICATIONS				TEST CONDITIONS
		MIN.	TYP.	MAX.	UNIT	
Operation voltage	$V_{DD}$	1.8	-	3.6	V	$V_{DD} = 1.8V$ up to 42 MHz
Power Ground	$V_{SS}$ $AV_{SS}$	-0.3	-		V	
LDO Output Voltage	$V_{LDO1}$	1.62	1.8	1.98	V	MCU operating in Run or Idle mode
	$V_{LDO2}$	1.49	1.66	1.83	V	MCU operating in Power-down mode

PARAMETER	SYM.	SPECIFICATIONS				TEST CONDITIONS
		MIN.	TYP.	MAX.	UNIT	
Analog Operating Voltage	AV <sub>DD</sub>		V <sub>DD</sub>		V	
Reference Voltage	V <sub>ref</sub>	1.8		AV <sub>DD</sub>	V	
Run Mode at IRC = 12 MHz Crystal Oscillator Disable all peripheral						CPU run while(1) in FLASH ROM Clock = 12 MHz Crystal Oscillator Disable all peripheral
Operating Current Run Mode at XTAL 12 MHz, HCLK = 42 MHz	I <sub>DD1</sub>		20.5		mA	V <sub>DD</sub> = 3.6V at 42 MHz, all IP and PLL enabled <sup>[*5]</sup>
	I <sub>DD2</sub>		10.6		mA	V <sub>DD</sub> = 3.6V at 42 MHz all IP disabled and PLL enabled
	I <sub>DD3</sub>		19.1		mA	V <sub>DD</sub> = 1.8V at 42 MHz all IP and PLL enabled <sup>[*5]</sup>
	I <sub>DD4</sub>		10.3		mA	V <sub>DD</sub> = 1.8V at 42 MHz all IP disabled and PLL enabled
Operating Current Run Mode at XTAL 12 MHz, HCLK = 32 MHz	I <sub>DD5</sub>		16.2		mA	V <sub>DD</sub> = 3.6V at 32 MHz, all IP and PLL enabled <sup>[*5]</sup>
	I <sub>DD6</sub>		8.3		mA	V <sub>DD</sub> = 3.6V at 32 MHz all IP disabled and PLL enabled
	I <sub>DD7</sub>		15.3		mA	V <sub>DD</sub> = 1.8V at 32 MHz all IP and PLL enabled <sup>[*5]</sup>
	I <sub>DD8</sub>		8.0		mA	V <sub>DD</sub> = 1.8V at 32 MHz all IP disabled and PLL enabled
Operating Current Run Mode at XTAL 12 MHz, HCLK = 12 MHz	I <sub>DD9</sub>		6.4		mA	V <sub>DD</sub> = 3.6V at 12 MHz, all IP enabled and PLL disabled
	I <sub>DD10</sub>		2.8		mA	V <sub>DD</sub> = 3.6V at 12 MHz, all IP and PLL disabled
	I <sub>DD11</sub>		6.3		mA	V <sub>DD</sub> = 1.8V at 12 MHz, all IP enabled and PLL disabled
	I <sub>DD12</sub>		2.8		mA	V <sub>DD</sub> = 1.8V at 12 MHz, all IP and PLL disabled
Operating Current Run Mode	I <sub>DD13</sub>		6.7		mA	V <sub>DD</sub> = 3.6V at 12 MHz, all IP enabled and PLL disabled

PARAMETER	SYM.	SPECIFICATIONS				TEST CONDITIONS
		MIN.	TYP.	MAX.	UNIT	
at IRC 12 MHz, HCLK = 12 MHz	I <sub>DD14</sub>		3.0		mA	V <sub>DD</sub> = 3.6V at 12 MHz, all IP and PLL disabled
	I <sub>DD15</sub>		6.6		mA	V <sub>DD</sub> = 1.8V at 12 MHz, all IP enabled and PLL disabled
	I <sub>DD16</sub>		3.0		mA	V <sub>DD</sub> = 1.8V at 12 MHz, all IP and PLL disabled
Operating Current Run Mode at XTAL 4 MHz, HCLK = 4 MHz	I <sub>DD17</sub>		3.3		mA	V <sub>DD</sub> = 3.6V at 4 MHz, all IP enabled and PLL disabled
	I <sub>DD18</sub>		1.3		mA	V <sub>DD</sub> = 3.6V at 4 MHz, all IP and PLL disabled
	I <sub>DD19</sub>		3.2		mA	V <sub>DD</sub> = 1.8V at 4 MHz, all IP enabled and PLL disabled
	I <sub>DD20</sub>		1.3		mA	V <sub>DD</sub> = 1.8V at 4 MHz, all IP and PLL disabled
Operating Current Run Mode at XTAL 32.768 kHz, HCLK = 32.768 kHz	I <sub>DD21</sub>		82		uA	V <sub>DD</sub> = 3.6V at 32.768 kHz all IP enabled and PLL disabled,
	I <sub>DD22</sub>		74		uA	V <sub>DD</sub> = 3.6V at 32.768 kHz all IP and PLL disabled
	I <sub>DD23</sub>		77		uA	V <sub>DD</sub> = 1.8V at 32.768 kHz all IP enabled and PLL disabled
	I <sub>DD24</sub>		68		uA	V <sub>DD</sub> = 1.8V at 32.768 kHz all IP and PLL disabled
Operating Current Run Mode at IRC 10 kHz, HCLK = 10 kHz	I <sub>DD25</sub>		70		uA	V <sub>DD</sub> = 3.6V at 10 kHz all IP enabled and PLL disabled
	I <sub>DD26</sub>		68		uA	V <sub>DD</sub> = 3.6V at 10 kHz all IP and PLL disabled
	I <sub>DD27</sub>		65		uA	V <sub>DD</sub> = 1.8V at 10 kHz all IP enabled and PLL disabled
	I <sub>DD28</sub>		62		uA	V <sub>DD</sub> = 1.8V at 10 kHz all IP and PLL disabled
Operating Current Idle Mode at XTAL 12 MHz, HCLK = 42 MHz	I <sub>IDLE1</sub>		14.5		mA	V <sub>DD</sub> = 3.6V at 42 MHz all IP and PLL enabled <sup>[*5]</sup>
	I <sub>IDLE2</sub>		4.6		mA	V <sub>DD</sub> =3.6V at 42 MHz all IP disabled and PLL enabled

PARAMETER	SYM.	SPECIFICATIONS				TEST CONDITIONS
		MIN.	TYP.	MAX.	UNIT	
	I <sub>IDLE3</sub>		13.8		mA	V <sub>DD</sub> = 1.8V at 42MHz all IP and PLL enabled <sup>[*5]</sup>
	I <sub>IDLE4</sub>		4.5		mA	V <sub>DD</sub> = 1.8V at 42 MHz all IP disabled and PLL enabled
Operating Current Idle Mode at XTAL 12 MHz, HCLK = 32 MHz	I <sub>IDLE5</sub>		11.6		mA	V <sub>DD</sub> = 3.6V at 32 MHz all IP and PLL enabled <sup>[*5]</sup>
	I <sub>IDLE6</sub>		3.6		mA	V <sub>DD</sub> =3.6V at 32 MHz all IP disabled and PLL enabled
	I <sub>IDLE7</sub>		11.1		mA	V <sub>DD</sub> = 1.8V at 32MHz all IP and PLL enabled <sup>[*5]</sup>
	I <sub>IDLE8</sub>		3.6		mA	V <sub>DD</sub> = 1.8V at 32 MHz all IP disabled and PLL enabled
Operating Current Idle Mode at XTAL 12 MHz, HCLK = 12 MHz	I <sub>IDLE9</sub>		4.7		mA	V <sub>DD</sub> = 3.6V at 12 MHz, all IP enabled and PLL disabled
	I <sub>IDLE10</sub>		0.99		mA	V <sub>DD</sub> = 3.6V at 12 MHz, all IP and PLL disabled
	I <sub>IDLE11</sub>		4.6		mA	V <sub>DD</sub> = 1.8V at 12 MHz, all IP enabled and PLL disabled
	I <sub>IDLE12</sub>		0.94		mA	V <sub>DD</sub> = 1.8V at 12 MHz, all IP and PLL disabled
Operating Current Idle Mode at IRC 12 MHz, HCLK = 12 MHz	I <sub>IDLE13</sub>		5.9		mA	V <sub>DD</sub> = 3.6V at 12 MHz, all IP enabled and PLL disabled
	I <sub>IDLE14</sub>		1.3		mA	V <sub>DD</sub> = 3.6V at 12 MHz, all IP and PLL disabled
	I <sub>IDLE15</sub>		4.9		mA	V <sub>DD</sub> = 1.8V at 12 MHz, all IP enabled and PLL disabled
	I <sub>IDLE16</sub>		1.3		mA	V <sub>DD</sub> = 1.8V at 12 MHz, all IP and PLL disabled
Operating Current Idle Mode at XTAL 4 MHz, HCLK = 4 MHz	I <sub>IDLE17</sub>		2.7		mA	V <sub>DD</sub> = 3.6V at 4 MHz, all IP enabled and PLL disabled
	I <sub>IDLE18</sub>		0.66		mA	V <sub>DD</sub> = 3.6V at 4 MHz, all IP and PLL disabled
	I <sub>IDLE19</sub>		2.7		mA	V <sub>DD</sub> = 1.8V at 4 MHz, all IP enabled and PLL disabled

PARAMETER	SYM.	SPECIFICATIONS				TEST CONDITIONS
		MIN.	TYP.	MAX.	UNIT	
	I <sub>IDLE20</sub>		0.64		mA	V <sub>DD</sub> = 1.8V at 4 MHz, all IP and PLL disabled
Operating Current Idle Mode at XTAL 32.768 kHz, HCLK = 32.768 kHz	I <sub>IDLE21</sub>		78		uA	V <sub>DD</sub> = 3.6V at 32.768 kHz all IP enabled and PLL disabled
	I <sub>IDLE22</sub>		69		uA	V <sub>DD</sub> = 3.6V at 32.768 kHz all IP and PLL disabled
	I <sub>IDLE23</sub>		72		uA	V <sub>DD</sub> = 1.8V at 32.768 kHz all IP enabled and PLL disabled
	I <sub>IDLE24</sub>		63		uA	V <sub>DD</sub> = 1.8V at 32.768 kHz all IP and PLL disabled
Operating Current Idle Mode at IRC 10 kHz, HCLK = 10 kHz	I <sub>IDLE25</sub>		69		uA	V <sub>DD</sub> = 3.6V at 10 kHz all IP enabled and PLL disabled
	I <sub>IDLE26</sub>		66		uA	V <sub>DD</sub> = 3.6V at 10 kHz all IP and PLL disabled
	I <sub>IDLE27</sub>		63		uA	V <sub>DD</sub> = 1.8V at 10 kHz all IP enabled and PLL disabled
	I <sub>IDLE28</sub>		61		uA	V <sub>DD</sub> = 1.8V at 10 kHz all IP and PLL disabled
Standby Current Power-down Mode	I <sub>PWD1</sub>		1.2		μA	V <sub>DD</sub> = 3.6V, RTC OFF, all clock stop With RAM Retention, IO no loading
	I <sub>PWD2</sub>		0.8		μA	V <sub>DD</sub> = 1.8V, RTC OFF, all clock stop With RAM Retention, IO no loading
	I <sub>PWD3</sub>		2.8		μA	V <sub>DD</sub> = 3.6V, RTC ON, all clock stop except 32.768 kHz With RAM Retention, IO no loading
	I <sub>PWD4</sub>		2.0		μA	V <sub>DD</sub> = 1.8V, RTC ON, all clock stop except 32.768 kHz With RAM Retention, IO no loading
Input Pull Up Resistor PA, PB, PC, PD, PE, PF	R <sub>IN</sub>		40		KΩ	V <sub>DD</sub> = 3.3V
			98		KΩ	V <sub>DD</sub> = 1.8V
Input Leakage Current PA, PB, PC, PD, PE, PF	I <sub>LK</sub>	-0.1	-	+0.1	μA	V <sub>DD</sub> = 3.3V, 0 < V <sub>IN</sub> < V <sub>DD</sub>

PARAMETER	SYM.	SPECIFICATIONS				TEST CONDITIONS
		MIN.	TYP.	MAX.	UNIT	
Input Low Voltage PA, PB, PC, PD, PE, PF (Schmitt input)	V <sub>IL1</sub>		-	0.4V <sub>DD</sub>	V	
Input High Voltage PA, PB, PC, PD, PE, PF (Schmitt input)	V <sub>IH1</sub>	0.6V <sub>DD</sub>		5.5	V	ADC and DAC shared pins without Input 5V tolerance.
Hysteresis voltage of PA~PF (Schmitt input)	V <sub>HY</sub>		0.2V <sub>DD</sub>		V	
Input Low Voltage XT1_IN / XT1_OUT <sup>[*2]</sup>	V <sub>IL2</sub>	0	-	0.4		V <sub>DD</sub> = 1.8V
Input High Voltage XT1_IN / XT1_OUT <sup>[*2]</sup>	V <sub>IH2</sub>	1.5	-	V <sub>DD</sub> +0.2	V	V <sub>DD</sub> = 1.8V
Input Low Voltage X32I / X32O <sup>[*2]</sup>	V <sub>IL4</sub>	0	-	0.3	V	
Input High Voltage X32I / X32O <sup>[*2]</sup>	V <sub>IH4</sub>	1.5	-	1.98	V	
Negative going threshold (Schmitt input), /RESET	V <sub>ILS</sub>	1.28	1.33	1.37	V	V <sub>DD</sub> = 3.3V
Positive going threshold (Schmitt input), /RESET	V <sub>IHS</sub>	1.75	1.98	2.25	V	V <sub>DD</sub> = 3.3V
Source Current PA, PB, PC, PD, PE, PF (Push-pull Mode)	I <sub>SR21</sub>	-10	-14	-	mA	V <sub>DD</sub> = 3.3V, V <sub>S</sub> = V <sub>DD</sub> -0.7V
	I <sub>SR22</sub>	-3	-5	-	mA	V <sub>DD</sub> = 1.8V, V <sub>S</sub> = V <sub>DD</sub> -0.45V
Sink Current PA, PB, PC, PD, PE, PF (Push-pull Mode)	I <sub>SK21</sub>	10	15	-	mA	V <sub>DD</sub> = 3.3V, V <sub>S</sub> = 0.7V
	I <sub>SK22</sub>	3	6	-	mA	V <sub>DD</sub> = 1.8V, V <sub>S</sub> = 0.45V

**Note:**

1. /RESET pin is a Schmitt trigger input.
2. Crystal Input is a CMOS input.
3. It is recommended that a 10uF or higher capacitor and a 100nF bypass capacitor are connected between VDD and the closest VSS pin of the device.
4. For ensuring power stability, a 4.7uF or higher capacitor must be connected between LDO pin and the closest VSS pin of the device. Also a 100nF bypass capacitor between LDO and VSS help suppressing output noise.
5. All peripherals' clock source is from HXT (12 MHz), except SPI from HCLK.



### 9.3 AC Electrical Characteristics

#### 9.3.1 External Input Clock

PARAMETER	SYM.	SPECIFICATIONS				TEST CONDITION
		MIN.	TYP.	MAX.	UNIT	
Clock High Time	$t_{CHCX}$	10	-		nS	
Clock Low Time	$t_{CLCX}$	10	-		nS	
Clock Rise Time	$t_{CLCH}$	2	-	15	nS	
Clock Fall Time	$t_{CHCL}$	2	-	15	nS	

**Note:** Duty cycle is 50%.

#### 9.3.2 External 4~24 MHz XTAL Oscillator

PARAMETER	SYM.	SPECIFICATIONS				TEST CONDITION
		MIN.	TYP.	MAX.	UNIT	
Oscillator frequency	$f_{HXT}$	4	12	24	MHz	$V_{DD} = 1.8V \sim 3.6V$
Temperature	$T_{HXT}$	-40	-	+85	°C	
Operating current	$I_{HXT}$		0.3		mA	$V_{DD} = 3.0V$

##### 9.3.2.1 Typical Crystal Application Circuits

CRYSTAL	C1	C2	R
4MHz ~ 24 MHz	Optional(Depend on crystal specification)		without

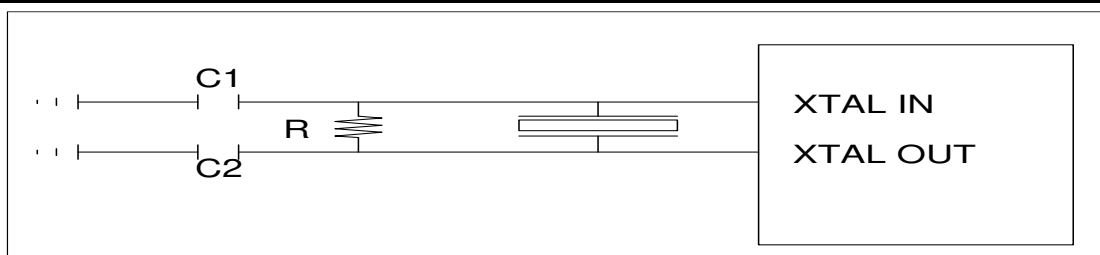

Figure 9-1 Typical Crystal Application Circuit

9.3.3 External 32.768 kHz Crystal

PARAMETER	SYM.	SPECIFICATIONS				TEST CONDITION
		MIN.	TYP.	MAX.	UNIT	
Oscillator frequency	f <sub>LXT</sub>		32.768		kHz	V <sub>DD</sub> = 1.8V ~ 3.6V
Temperature	T <sub>LXT</sub>	-40	-	+85	°C	
Operating current	I <sub>LXT</sub>		1.2		μA	V <sub>DD</sub> = 3.0V

9.3.4 Internal 12 MHz Oscillator

PARAMETER	SYM.	SPECIFICATIONS				TEST CONDITION
		MIN.	TYP.	MAX.	UNIT	
Supply voltage <sup>[1]</sup>	V <sub>HRC</sub>		1.8		V	
Calibrated Internal Oscillator Frequency	F <sub>HRC</sub>	11.88	12	12.12	MHz	25°C, V <sub>DD</sub> = 3V
		11.76	12	12.24	MHz	-40°C~+85°C, V <sub>DD</sub> = 1.8V~3.6V
		11.97	12	12.03	MHz	-40°C~+85°C, V <sub>DD</sub> = 1.8V~3.6V Enable 32.768K crystal oscillator and set TRIM_SEL[1:0]="10"
Operating current	I <sub>HRC</sub>		450		μA	

Note: Internal oscillator operation voltage comes from LDO.

9.3.5 Internal 10 kHz Oscillator

PARAMETER	SYM.	SPECIFICATIONS				TEST CONDITION
		MIN.	TYP.	MAX.	UNIT	
Supply voltage <sup>[1]</sup>	V <sub>LRC</sub>		1.8		V	
Center Frequency	F <sub>LRC</sub>	7	10	13	kHz	25°C, V <sub>DD</sub> = 3V
		5	10	15	kμHz	-40°C~+85°C, V <sub>DD</sub> = 1.8V~3.6V
Operating current	I <sub>LRC</sub>		0.7		μA	V <sub>DD</sub> = 3V

Note: Internal oscillator operation voltage comes from LDO.

9.4 Analog Characteristics

9.4.1 12-bit ADC

PARAMETER	SYM.	SPECIFICATIONS				TEST CONDITION
		MIN.	TYP.	MAX.	UNIT	
Operating voltage	AV <sub>DD</sub>	1.8		3.6	V	AV <sub>DD</sub> = V <sub>DD</sub>

PARAMETER	SYM.	SPECIFICATIONS				TEST CONDITION
		MIN.	TYP.	MAX.	UNIT	
Operating current	I <sub>ADC42</sub>		147		μA	AV <sub>DD</sub> = V <sub>DD</sub> = 3.0V ADC_VREF = AV <sub>DD</sub> ADC Clock Rate = 42 MHz
	I <sub>ADC12</sub>		50		μA	AV <sub>DD</sub> = V <sub>DD</sub> = 3.0V ADC_VREF = AV <sub>DD</sub> ADC Clock Rate = 12 MHz
Resolution	R <sub>ADC</sub>			12	Bit	
Reference voltage	V <sub>REF</sub>	1.8		A <sub>VDD</sub>	V	
Reference input current (Avg.)	I <sub>REF</sub>			10	μA	
ADC input voltage	V <sub>IN</sub>	0		V <sub>REF</sub>	V	
Conversion time	T <sub>CONV</sub>	0.5			μS	
Sampling Rate	F <sub>SPS</sub>			2M	Hz	V <sub>DD</sub> = 3V
Integral Non-Linearity Error	INL		±1	±2	LSB	V <sub>REF</sub> is external Vref pin
Differential Non-Linearity	DNL		±0.8	-1~+1.5	LSB	V <sub>REF</sub> is external Vref pin
Gain error	E <sub>G</sub>		-	±2	LSB	V <sub>REF</sub> is external Vref pin
Offset error	E <sub>OFFSET</sub>		-	±3	LSB	V <sub>REF</sub> is external Vref pin
Absolute error	E <sub>ABS</sub>		-	±6	LSB	V <sub>REF</sub> is external Vref pin
ADC Clock frequency	F <sub>ADC</sub>	0.25		42	MHz	
Clock cycle	AD <sub>CYC</sub>	20			Cycle	
Internal Capacitance	C <sub>IN</sub>	-	5	-	pF	
Monotonic	-	Guaranteed			-	

9.4.2 Brown-out Detector

PARAMETER	SYM.	SPECIFICATIONS				TEST CONDITION
		MIN.	TYP.	MAX.	UNIT	
Operating voltage	V <sub>BOD</sub>	1.8		3.6	V	
BOD17 Quiescent current	I <sub>BOD17</sub>		1		μA	AV <sub>DD</sub> = 3.0V, BOD17 enabled
BOD20 Quiescent current	I <sub>BOD20</sub>		1		μA	AV <sub>DD</sub> = 3.0V, BOD20 enabled
BOD25 Quiescent current	I <sub>BOD25</sub>		1		μA	AV <sub>DD</sub> = 3.0V, BOD25 enabled
BOD17 detection level	V <sub>B17dt</sub>	1.6	1.7	1.8	V	25°C
BOD20 detection level	V <sub>B20dt</sub>	1.9	2.0	2.1	V	25°C
BOD25 detection level	V <sub>B25dt</sub>	2.4	2.5	2.6	V	25°C

9.4.3 Power-on Reset

PARAMETER	SYM.	SPECIFICATIONS				TEST CONDITION
		MIN.	TYP.	MAX.	UNIT	
Reset voltage	V <sub>POR</sub>	-	1.6	-	V	
Quiescent current	I <sub>POR</sub>	-	1	-	nA	LDO output > Reset voltage

9.4.4 Temperature Sensor

PARAMETER	SYM.	SPECIFICATIONS				TEST CONDITION (SUPPLY VOLTAGE = 3.36V)
		MIN.	TYP.	MAX.	UNIT	
Detection Temperature	T <sub>DET</sub>	-40		+110	°C	
Operating current	I <sub>TEMP</sub>	-	5	-	μA	
Gain	V <sub>TG</sub>	-1.80	-1.73	-1.65	mV/°C	
Offset	V <sub>TO</sub>	730	740	750	mV	Temperature at 0 °C

Note: Internal operation voltage comes form LDO.

9.4.5 12-bit DAC

PARAMETER	SYM.	SPECIFICATIONS				TEST CONDITION
		MIN.	TYP.	MAX.	UNIT	
Operating voltage	AV <sub>DD</sub>	2.0		3.6	V	AV <sub>DD</sub> = V <sub>DD</sub>
Operating current	I <sub>DAC</sub>		2.20		mA	AV <sub>DD</sub> = V <sub>DD</sub> = 3.0V, DAC_VREF = AV <sub>DD</sub> DAC conversion rate 500kHz
Resolution	R <sub>ADC</sub>			12	Bit	
Reference voltage	V <sub>REF</sub>	1.8		A <sub>VDD</sub>	V	
Reference input current (Avg.)	I <sub>REF</sub>		0.85		mA	AV <sub>DD</sub> = V <sub>DD</sub> = 3.0V DAC_VREF=Ext_Vref DAC conversion rate 500kHz
DAC output swin range	V <sub>OUT</sub>	0.1 x V <sub>REF</sub>	-	0.9 x V <sub>REF</sub>	V	
Conversion Rate (code to adjacent code)	F <sub>SPS</sub>			500	kHz	V <sub>DD</sub> = 3V
Integral Non-Linearity Error	INL		±4	±5	LSB	V <sub>REF</sub> is external Vref pin Not include offset and gain error
Differential Non-Linearity	DNL		±1	±2	LSB	V <sub>REF</sub> is external Vref pin Not include offset and gain error
Gain error	E <sub>G</sub>		290		LSB	
Offset error	E <sub>OFFSET</sub>		150		LSB	

9.4.6 LCD

PARAMETER	SYM.	SPECIFICATIONS				TEST CONDITION
		MIN.	TYP.	MAX.	UNIT	
Operating voltage	V <sub>DD</sub>	1.8	-	3.6	V	
VLCD voltage	V <sub>LCD34</sub>	-	3.4	-	V	CPUMP_VOL_SET=111, no loading
VLCD voltage	V <sub>LCD33</sub>	-	3.3	-	V	CPUMP_VOL_SET=110, no loading
VLCD voltage	V <sub>LCD32</sub>	-	3.2	-	V	CPUMP_VOL_SET=101, no loading
VLCD voltage	V <sub>LCD31</sub>	-	3.1	-	V	CPUMP_VOL_SET=100, no loading
VLCD voltage	V <sub>LCD30</sub>	-	3.0	-	V	CPUMP_VOL_SET=011, no loading
VLCD voltage	V <sub>LCD29</sub>	-	2.9	-	V	CPUMP_VOL_SET=010, no loading
VLCD voltage	V <sub>LCD28</sub>	-	2.8	-	V	CPUMP_VOL_SET=001, no loading
VLCD voltage	V <sub>LCD27</sub>	-	2.7	-	V	CPUMP_VOL_SET=000, no loading
Operating current	I <sub>LCD</sub>	-	10	-	μA	V <sub>DD</sub> = 3V, frame rate = 32Hz Without loading

9.4.7 Internal Voltage Reference

PARAMETER	SYM.	SPECIFICATIONS				TEST CONDITION
		MIN.	TYP.	MAX.	UNIT	
Operating voltage	AV <sub>DD</sub>	1.8	-	3.6	V	
1.8V voltage reference	V <sub>REF1</sub>	1.69	1.8	1.87	V	AV <sub>DD</sub> ≥ 2.0V (-40°C ~85°C)
2.5V voltage reference	V <sub>REF2</sub>	2.35	2.5	2.60	V	AV <sub>DD</sub> ≥ 2.8V (-40°C ~85°C)
Stable Time	T <sub>REFTAB</sub>	-	1	-	ms	
Operating current	I <sub>VREF</sub>	-	30	-	μA	AV <sub>DD</sub> = 3V

9.4.8 USB PHY Specifications

9.4.8.1 USB PHY DC Electrical Characteristics

SYMBOL	PARAMETER	CONDITION	MIN.	TYP.	MAX.	UNIT
V <sub>IH</sub>	Input high (driven)		2.0	-		V
V <sub>IL</sub>	Input low			-	0.8	V
V <sub>DI</sub>	Differential input sensitivity	PADP-PADM	0.2	-		V

V <sub>CM</sub>	Differential common-mode range	Includes V <sub>DI</sub> range	0.8	-	2.5	V
V <sub>SE</sub>	Single-ended receiver threshold		0.8	-	2.0	V
	Receiver hysteresis			200		mV
V <sub>OL</sub>	Output low (driven)		0	-	0.3	V
V <sub>OH</sub>	Output high (driven)		2.8	-	3.6	V
V <sub>CRS</sub>	Output signal cross voltage		1.3	-	2.0	V
R <sub>PU</sub>	Pull-up resistor		1.425	-	1.575	kΩ
R <sub>PD</sub>	Pull-down resistor		14.25	-	15.75	kΩ
V <sub>TRM</sub>	Termination Voltage for upstream port pull up (RPU)		3.0	-	3.6	V
Z <sub>DRV</sub>	Driver output resistance	Steady state drive*		10		Ω
C <sub>IN</sub>	Transceiver capacitance	Pin to GND		-	20	pF

\*Driver output resistance doesn't include series resistor resistance.

9.4.8.2 USB PHY Full-Speed Driver Electrical Characteristics

SYMBOL	PARAMETER	CONDITION	MIN.	TYP.	MAX.	UNIT
T <sub>FR</sub>	Rise Time	C <sub>L</sub> =50p	4	-	20	ns
T <sub>FF</sub>	Fall Time	C <sub>L</sub> =50p	4	-	20	ns
T <sub>FRFF</sub>	Rise and fall time matching	T <sub>FRFF</sub> =T <sub>FR</sub> /T <sub>FF</sub>	90	-	111.11	%

9.4.8.3 USB PHY Power Dissipation

SYMBOL	PARAMETER	CONDITION	MIN.	TYP.	MAX.	UNIT
I <sub>VDDREG</sub> (Full Speed)	V <sub>DDD</sub> and V <sub>DDREG</sub> Supply Current (Steady State)	Standby		50		uA

9.4.8.4 USB LDO DC Electrical Characteristics

SYMBOL	PARAMETER	CONDITION	MIN.	TYP.	MAX.	UNIT
V <sub>BUS</sub>				5		V
V <sub>33</sub>	Output voltage	V <sub>BUS</sub> = 5V, 25°C	2.97	3.3	3.63	V
I <sub>op</sub>	Operation Current			100		uA

9.5 Flash DC Electrical Characteristics

Symbol	Parameter	Min	Typ	Max	Unit	Test Condition
V <sub>FLA</sub> <sup>[2]</sup>	Supply Voltage	1.62	1.8	1.98	V	
N <sub>ENDUR</sub>	Endurance	20000			cycles <sup>[1]</sup>	
T <sub>RET</sub>	Data Retention	100			year	T <sub>A</sub> = 25°C
T <sub>ERASE</sub>	Page Erase Time	-	20	-	ms	
T <sub>PROG</sub>	Program Time	-	40	-	us	
I <sub>DD1</sub>	Read Current			0.150	mA/MHz	
I <sub>DD2</sub>	Program Current			7	mA	
I <sub>DD3</sub>	Erase Current			7	mA	

Notes:

1. Number of program/erase cycles.
2. V<sub>FLA</sub> is source from chip LDO output voltage.
3. Guaranteed by design, not test in production.

10 PACKAGE DIMENSIONS

10.1 LQFP128 (14x14x1.4 mm footprint 2.0 mm)

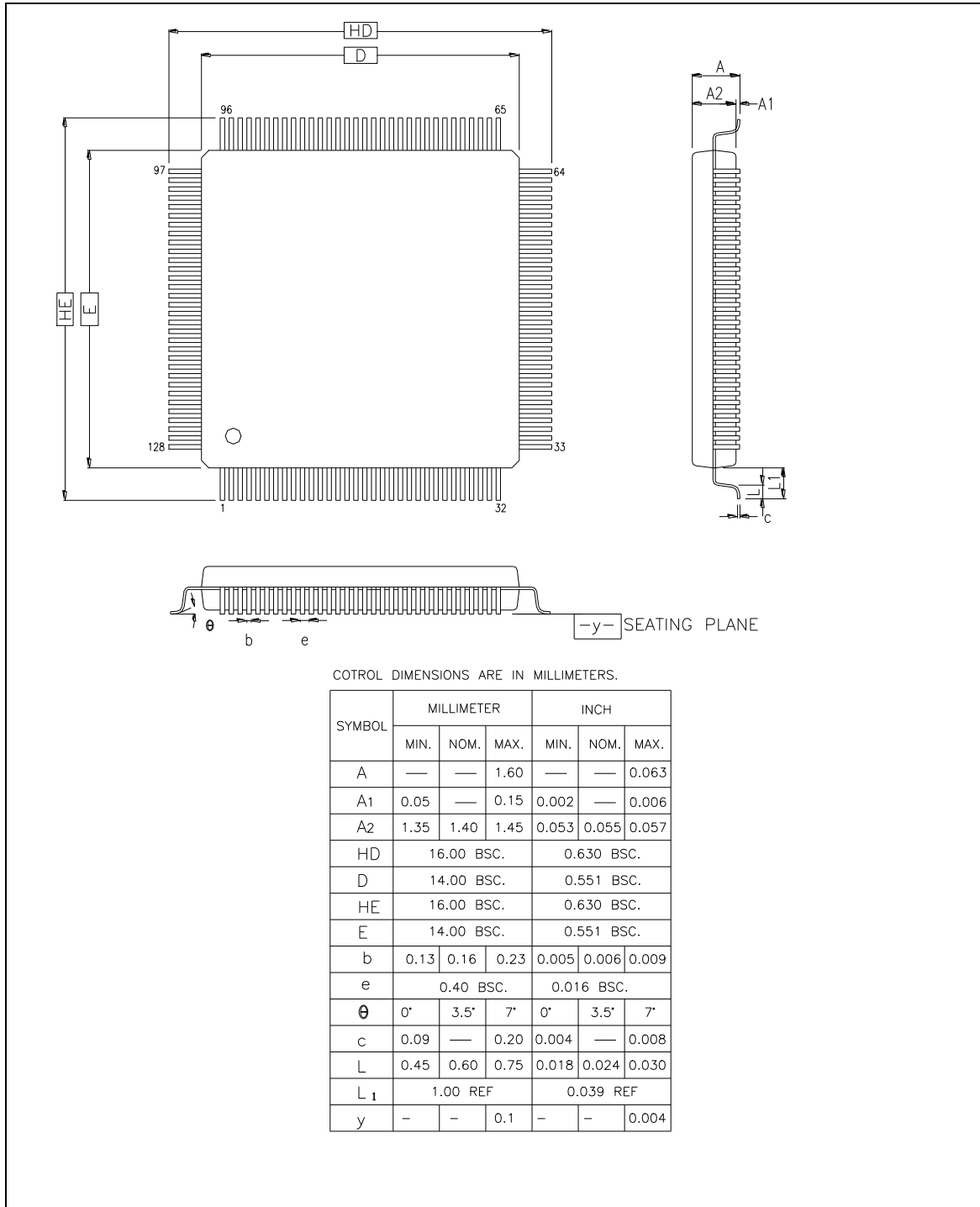



10.2 LQFP64 (10x10x1.4 mm footprint 2.0 mm)

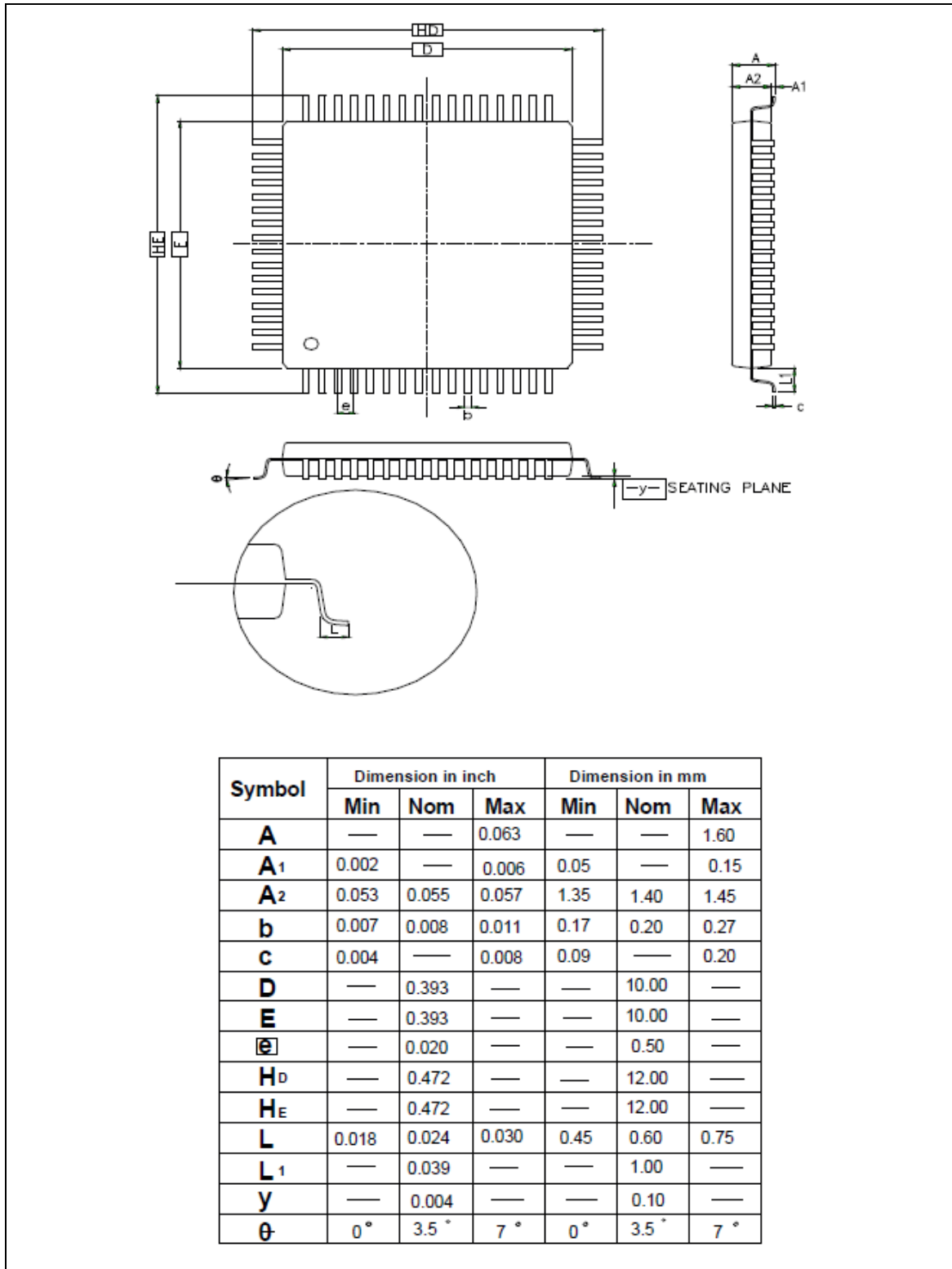

10.3 LQFP64 (7x7x1.4 mm footprint 2.0 mm)

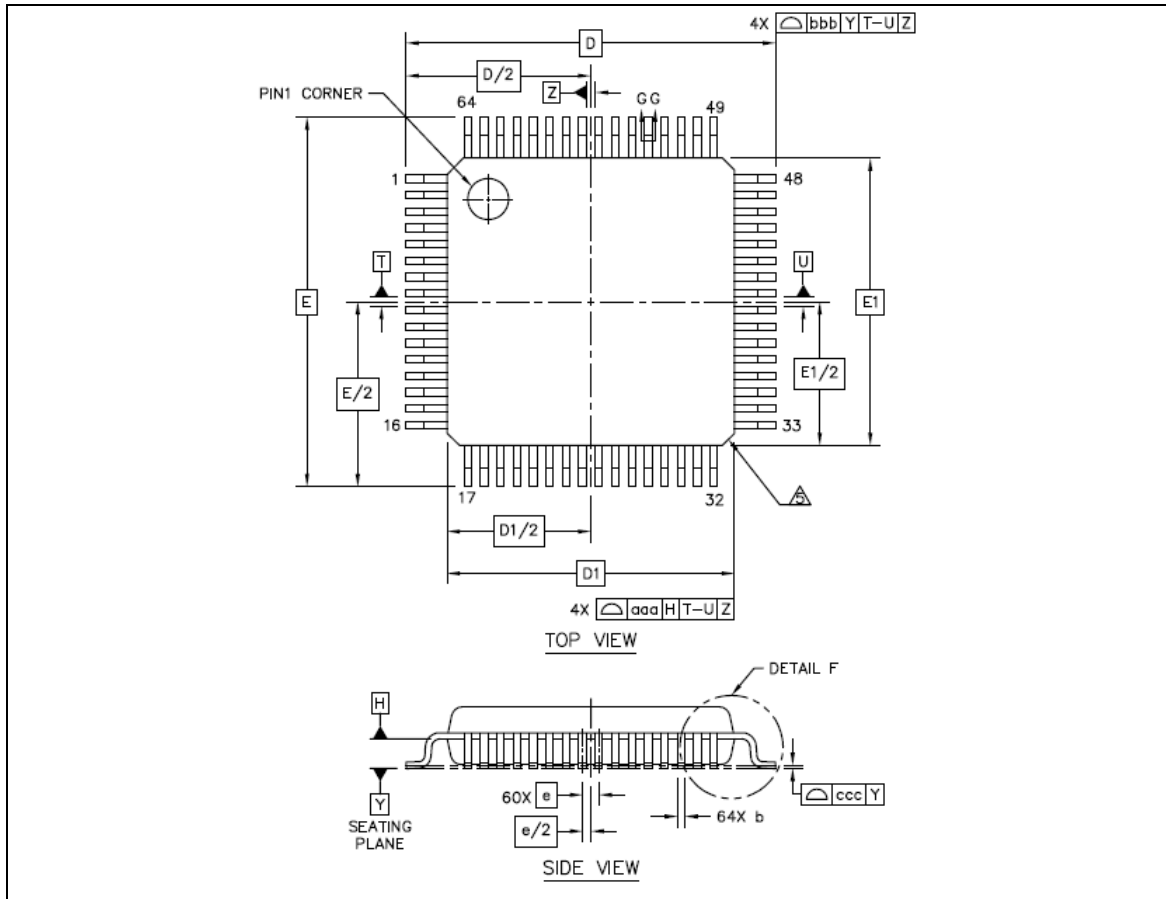

	SYMBOL	MIN	NOM	MAX
TOTAL THICKNESS	A	----	----	1.6
STAND OFF	A1	0.05	----	0.15
MOLD THICKNESS	A2	1.35	1.4	1.45
LEAD WIDTH(PLATING)	b	0.13	0.18	0.23
LEAD WIDTH	b1	0.13	0.16	0.19
L/F THICKNESS(PLATING)	c	0.09	----	0.2
L/F THICKNESS	c1	0.09	----	0.16
	X	D		
	Y	E		
	X	D1		
	Y	E1		
BODY SIZE	X	7 BSC		
	Y	7 BSC		
LEAD PITCH	e	0.4 BSC		
	L	0.45	0.6	0.75
FOOTPRINT	L1	1 REF		
	θ	0°	3.5°	7°
	θ1	0°	----	----
	θ2	11°	12°	13°
	θ3	11°	12°	13°
	R1	0.08	----	----
	R2	0.08	----	0.2
	S	0.2	----	----
PACKAGE EDGE TOLERANCE	aaa	0.2		
LEAD EDGE TOLERANCE	bbb	0.2		
COPLANARITY	ccc	0.08		
LEAD OFFSET	ddd	0.07		
MOLD FLATNESS	eee	0.05		

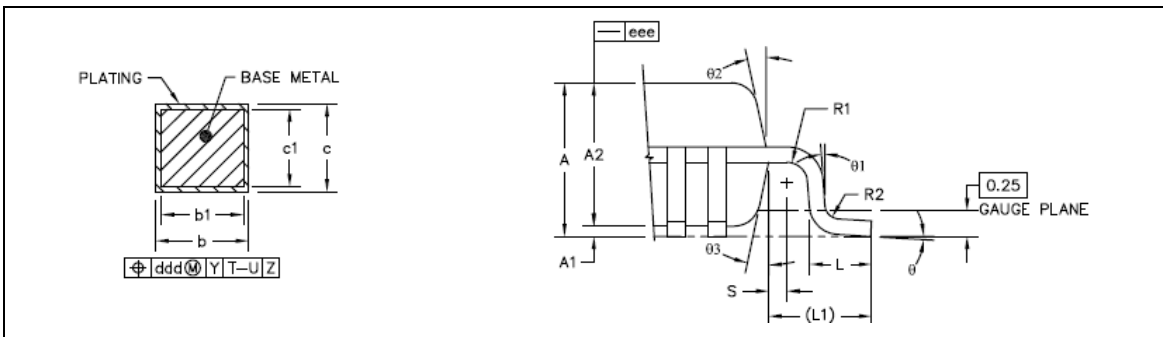

10.4 LQFP48 (7x7x1.4 mm footprint 2.0 mm)

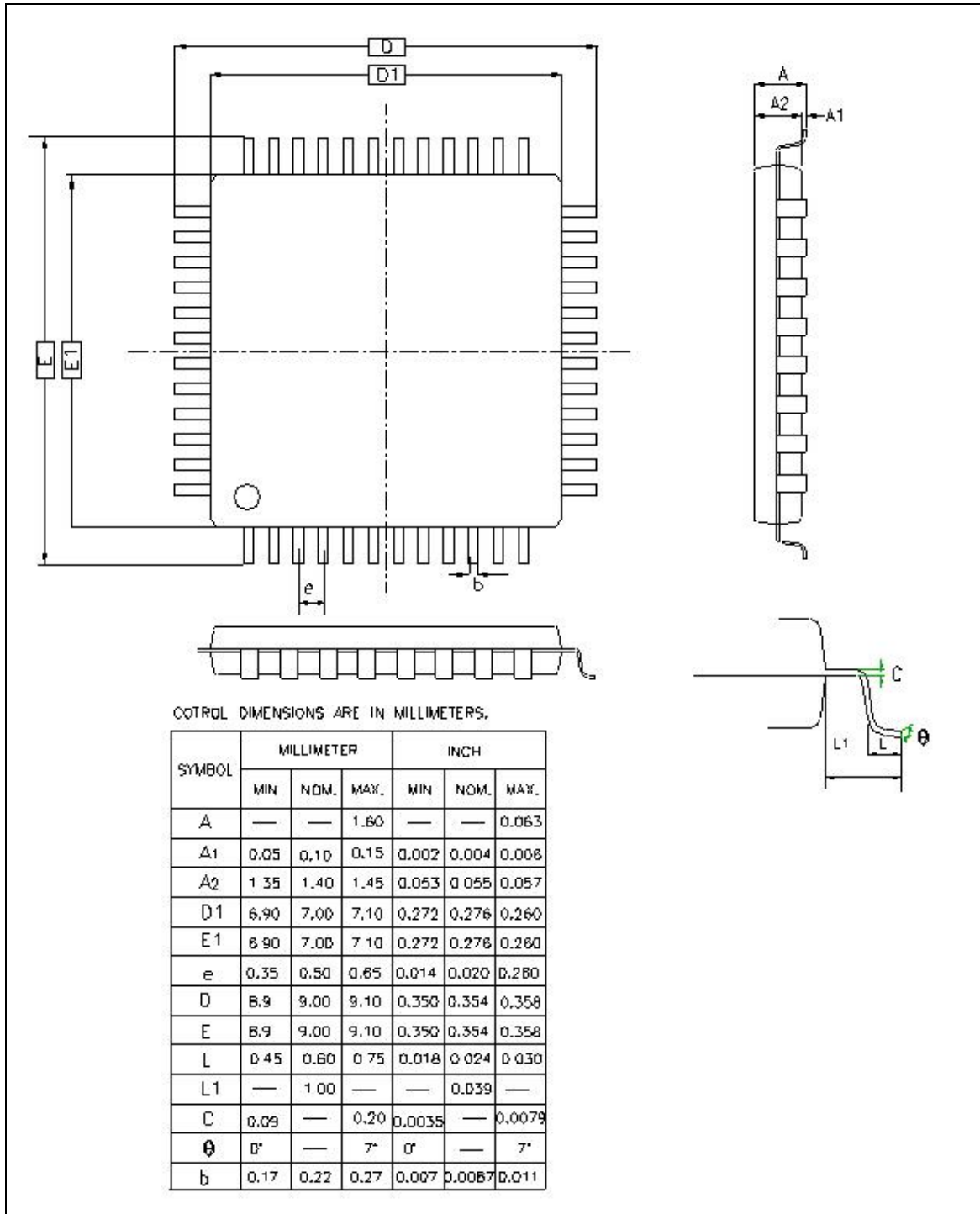

10.5 QFN48 (7x7x0.85 mm)

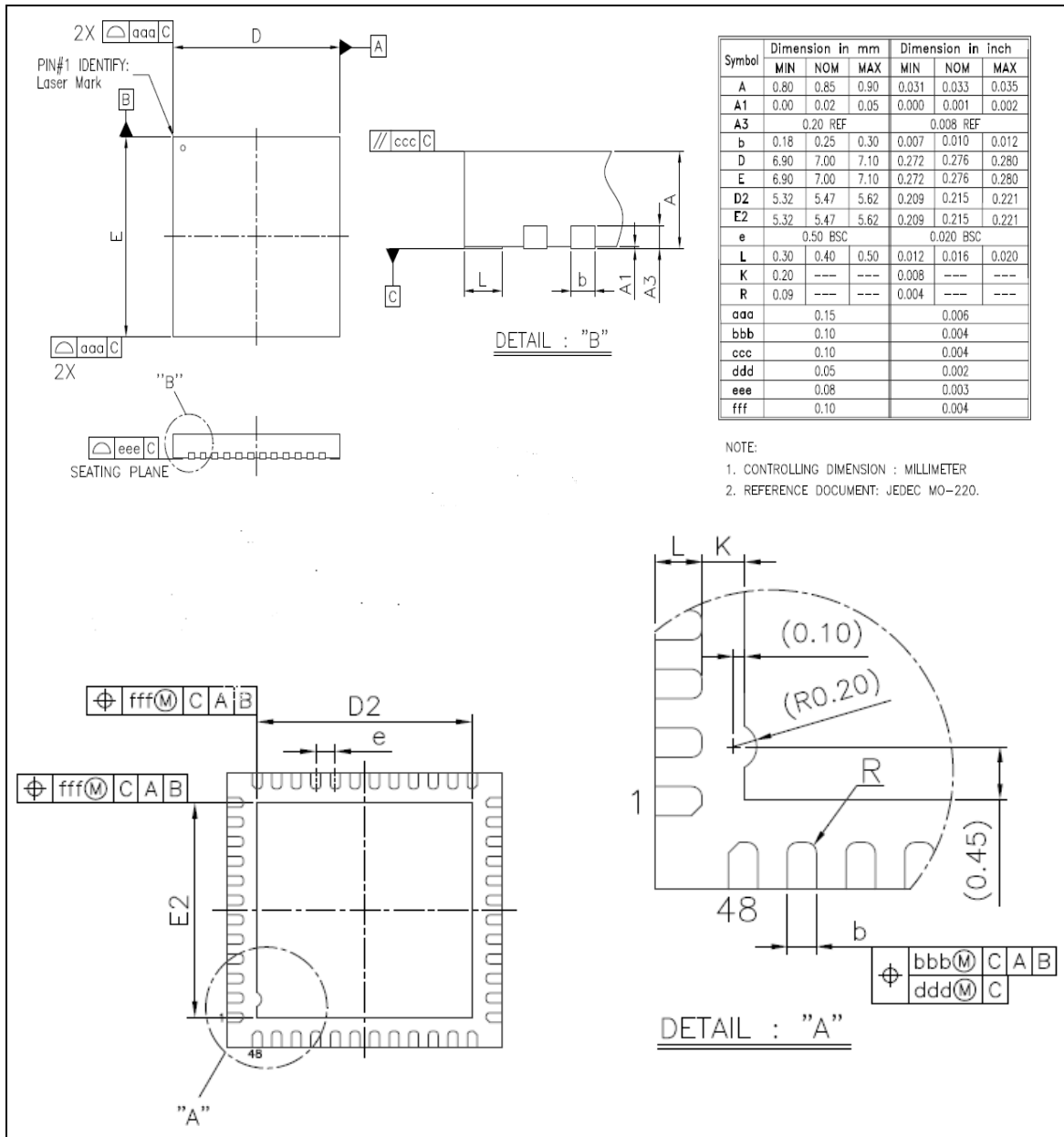

Symbol	Dimension in mm			Dimension in inch		
	MIN	NOM	MAX	MIN	NOM	MAX
A	0.80	0.85	0.90	0.031	0.033	0.035
A1	0.00	0.02	0.05	0.000	0.001	0.002
A3	0.20 REF			0.008 REF		
b	0.18	0.25	0.30	0.007	0.010	0.012
D	6.90	7.00	7.10	0.272	0.276	0.280
E	6.90	7.00	7.10	0.272	0.276	0.280
D2	5.32	5.47	5.62	0.209	0.215	0.221
E2	5.32	5.47	5.62	0.209	0.215	0.221
e	0.50 BSC			0.020 BSC		
L	0.30	0.40	0.50	0.012	0.016	0.020
K	0.20	---	---	0.008	---	---
R	0.09	---	---	0.004	---	---
aaa	0.15			0.006		
bbb	0.10			0.004		
ccc	0.10			0.004		
ddd	0.05			0.002		
eee	0.08			0.003		
fff	0.10			0.004		

NOTE:  
 1. CONTROLLING DIMENSION : MILLIMETER  
 2. REFERENCE DOCUMENT: JEDEC MO-220.

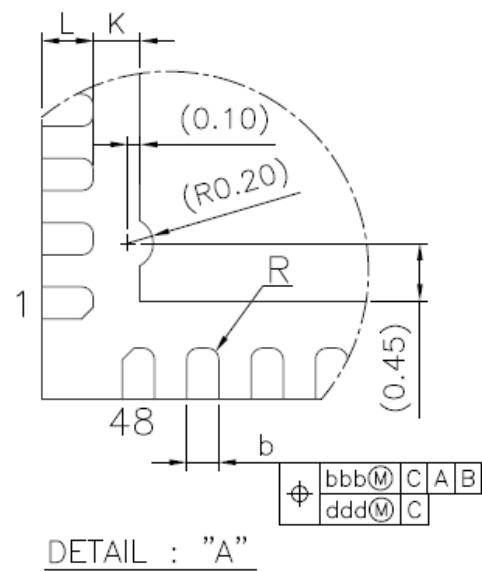

11 REVISION HISTORY

Date	Revision	Description
2012.10.11	1.00	<b>Initial release</b>
2012.12.11	1.01	<ol style="list-style-type: none"> <li>Added SmartCard UART mode description in Pin Description.</li> <li>Unified the abbreviation (TMR) in the Timer Controller section.</li> <li>Modified the specifications of external input clock.</li> <li>Added LCD COM4 and COM5 description for each pin description and diagram.</li> <li>Updated the ADC enabled by timer event description in the ADC section.</li> <li>Changed Timer0/1 Ch0/1 to Timer x (x=0, 1, 2, 3) in the Timer Controller section.</li> </ol>
2012.12.17	1.02	<ol style="list-style-type: none"> <li>Added description of reading UCID in ISP mode.</li> </ol>
2012.12.28	1.03	<ol style="list-style-type: none"> <li>Added R-type related description in LCD section.</li> <li>Updated the operating current data of Run mode and Idle mode at each frequency and added related data at 42 MHz in section 9.2.</li> </ol>
2013.01.02	1.04	<ol style="list-style-type: none"> <li>Updated the table in Power Consumption section.</li> </ol>
2013.03.05	1.05	<ol style="list-style-type: none"> <li>Updated the display modes from four to six in section 5.13.2.</li> <li>Corrected the pin descriptions in section 3.4.</li> <li>Updated temperature sensor of analog characteristic in section 9.4.4.</li> <li>Corrected Smart Card's feature to be half duplex in UART mode in section 5.16.2.</li> </ol>
2013.05.28	1.06	<ol style="list-style-type: none"> <li>Updated the Nano110 LQFP128-pin diagram in section 3.3.2.</li> <li>Updated "12 MHz OSC has 2 % deviation within all temperature range" in sections 2.1 to 2.4.</li> <li>Updated DAC analog characteristics in section 9.4.5.</li> <li>Added Nano110RC2BN to the Nano110 LCD Line Selection Guide.</li> </ol>
2013.12.04	1.07	<ol style="list-style-type: none"> <li>Updated Nano100 series selection code in section 3.1.</li> <li>Added the Nano100 QFN48 package in section 3.2 and QFN48 package dimensions in chapter 10.</li> <li>Fixed the typo of LCD characteristic in section 9.4.7.</li> <li>Added a note that "Output voltage for ADC/LCD shared pins cannot be higher than VDD because these pins are without 5V tolerance." for pin description in section 3.4, LCD overview in section 5.13.1 and Absolute Maximum Ratings in section 9.1.</li> <li>Modified the schematic for ADC and DAC application circuit in section</li> </ol>

7.2 and 7.3.

2016.05.31 1.08

- 
1. Added Flash DC Electrical Characteristics in section 9.5.
  2. Fixed the typo of LCD Feature in section 5.13.2.
  3. Fixed the typo of Products Selection Guide in section 3.2
  4. Modified the schematic for ADC, DAC and Whole Chip Application Circuit in section 7.2, 7.3 and 7.4.
-

### Important Notice

Nuvoton Products are neither intended nor warranted for usage in systems or equipment, any malfunction or failure of which may cause loss of human life, bodily injury or severe property damage. Such applications are deemed, "Insecure Usage".

Insecure usage includes, but is not limited to: equipment for surgical implementation, atomic energy control instruments, airplane or spaceship instruments, the control or operation of dynamic, brake or safety systems designed for vehicular use, traffic signal instruments, all types of safety devices, and other applications intended to support or sustain life.

All Insecure Usage shall be made at customer's risk, and in the event that third parties lay claims to Nuvoton as a result of customer's Insecure Usage, customer shall indemnify the damages and liabilities thus incurred by Nuvoton.

---

*Please note that all data and specifications are subject to change without notice.  
All the trademarks of products and companies mentioned in this datasheet belong to their respective owners.*