

CUSTOMER PRINT

PART NUMBER: 17282-XPG-300(CHX)

- NOTES:**
 1. ALL PARTS TO BE BULK PACKED.
 2. CONTACTS ARE ASSEMBLED INTO PANEL CONNECTOR.
 3. SEE DRAWING HPMCSTD FOR HOLE PATTERN

ASS'Y P/N	HEX NUT COLOR
17282-XPG-300CH1	WHITE
17282-XPG-300CH2	RED
17282-XPG-300CH3	BLUE
17282-XPG-300CH4	LIGHT GREY
17282-XPG-300CH5	YELLOW
17282-XPG-300CH6	MAROON
17282-XPG-300CH7	GREEN

ASS'Y P/N	NO. OF CONTACTS
17282-2PG-300	2-# 20
17282-3PS-300	3-# 20

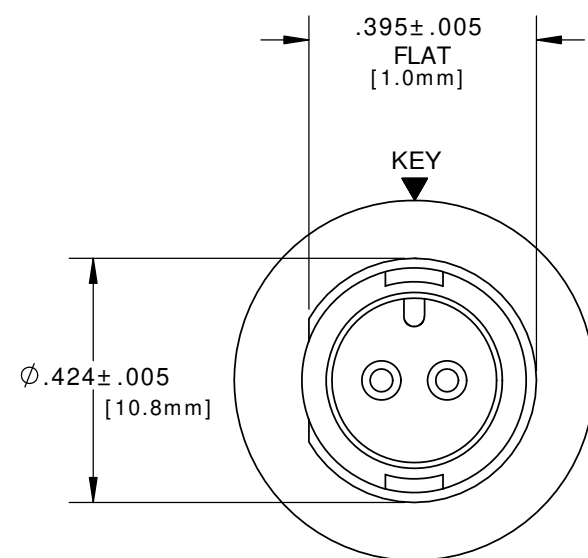

FACE VIEW

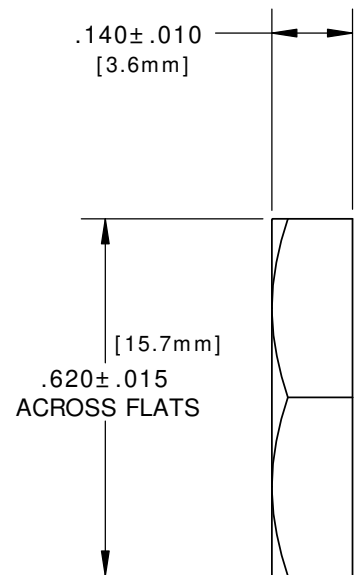

HEX NUT
 MAT'L: NYLON, BLACK
 FOR COLOR HEX NUT
 SEE CHART

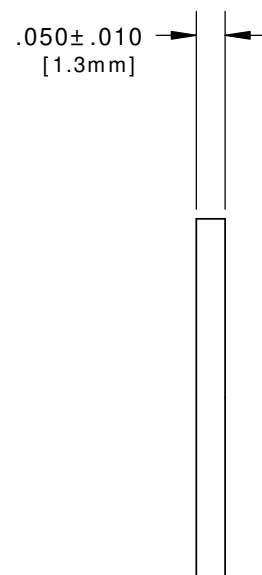

GASKET
 MAT'L: RUBBER, BLACK

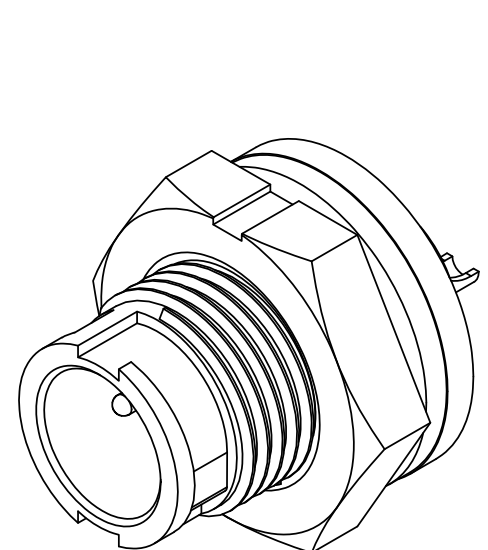
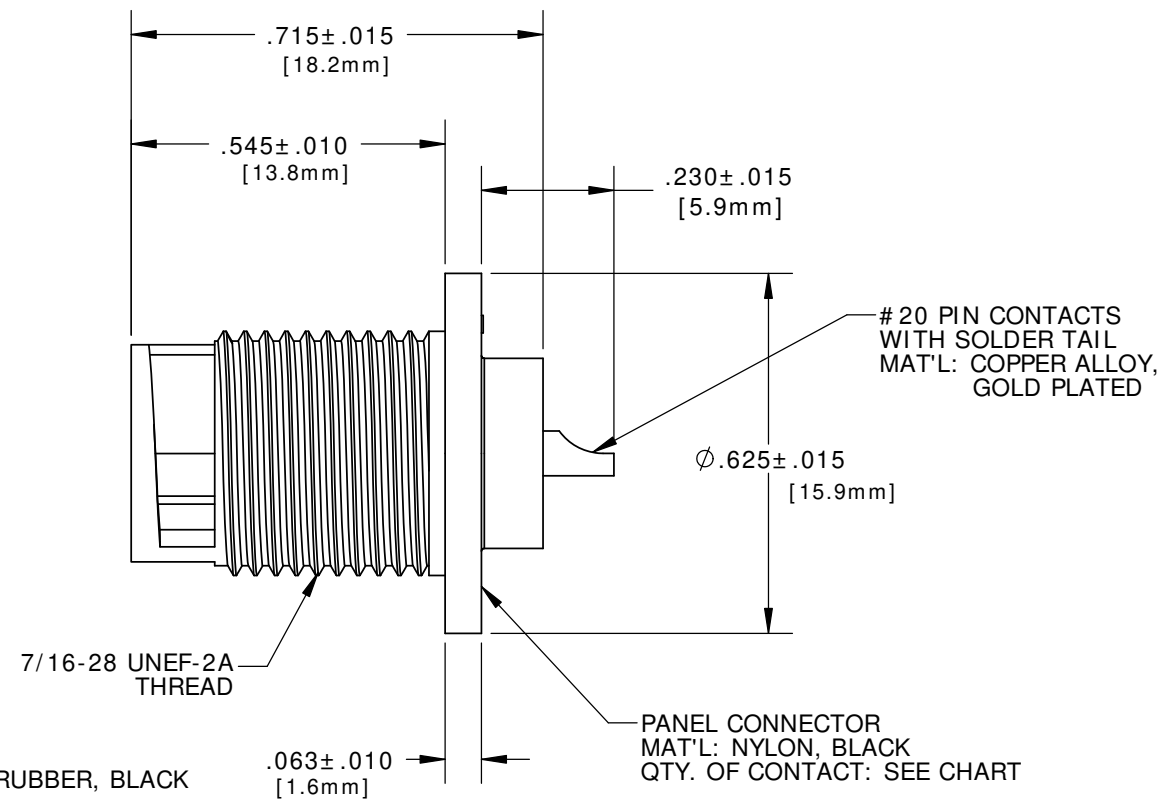

**SHOWN ASSEMBLED KIT
 FOR CUSTOMER REFERENCE ONLY**

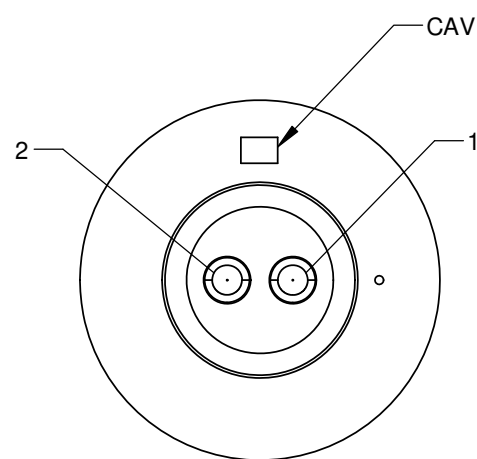

**WIRE VIEW
 17282-2PG-00**

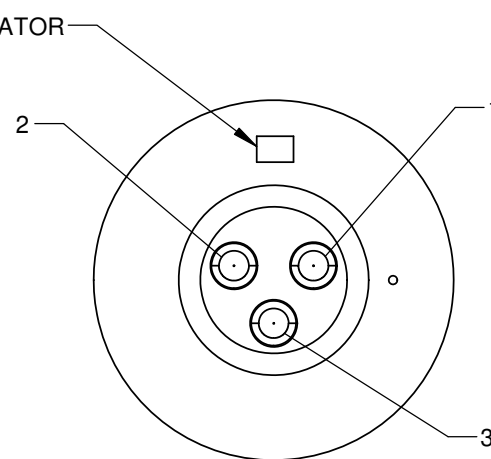

**WIRE VIEW
 17282-3PG-300**

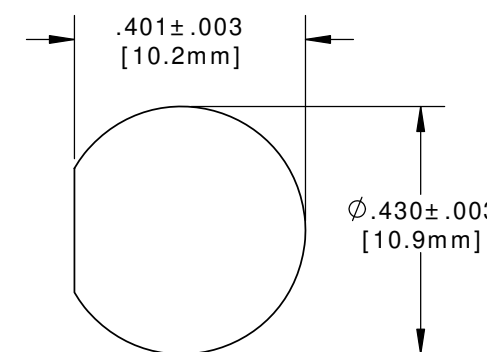

**RECOMMENDED
 PANEL CUT-OUT**

CUSTOMER APPROVAL
 THIS DOCUMENT CONTAINS CONFIDENTIAL INFORMATION PROPRIETARY TO CONXALL CORPORATION. ANY REPRODUCTION, DISCLOSURE, OR USE OF THIS DOCUMENT /INFORMATION IS EXPRESSLY PROHIBITED UNLESS AUTHORIZED IN WRITING BY CONXALL CORPORATION.
 APPROVED BY: _____
 DATE: _____

DIMENSIONS IN BRACKET [] ARE METRIC.

RoHS COMPLIANT

B	SS	04-08-19	ADDED HEX NUT COLOR CHART TO DRAWING PER DOR 19-E149SL #4
A	AN	05-17-11	DRAWING CREATED PER DOR 11-E149SL
REV.	INIT.	DATE	DESCRIPTION
	AN	05-17-11	ORIG. DRAWN BY: DATE: CHECKED BY:
ALL INFORMATION ILLUSTRATED IS THE PROPERTY OF CONXALL CORPORATION. UNAUTHORIZED DUPLICATION OR DISTRIBUTION OF THIS DOCUMENT IS PROHIBITED.			 601 E. WILDWOOD VILLA PARK, IL 60181
ALL UNITS ARE IN FEET, INCHES, FRACTION OF INCHES AND DECIMALS.			
APPROVED BY:		TITLE: PANEL CONNECTOR ASSEMBLY (2-3) #20 PIN CONTACTS, SOLDER TAIL MICRO-CON-X	
SCALE	SIZE	SHEET	CUSTOMER: STANDARD PRODUCT
NTS	B	1 OF 1	
FILE:	DIRECTORY:	PART NUMBER:	REV
17282-XPG-300(CHX)	SLW	17282-XPG-300(CHX)	B