

## FEATURES

- 4-quadrant multiplication
- Low cost, 8-lead SOIC package
- Complete—no external components required
- Laser-trimmed accuracy and stability
- Total error within 2% of full scale
- Differential high impedance X and Y inputs
- High impedance unity-gain summing input
- Laser-trimmed 10 V scaling reference

## ENHANCED PRODUCT FEATURES

- Supports defense and aerospace applications (AQEC standard)
- Military temperature range ( $-55^{\circ}\text{C}$  to  $+125^{\circ}\text{C}$ )
- Controlled manufacturing baseline
- One assembly/test site
- One fabrication site
- Enhanced product change notification
- Qualification data available on request

## APPLICATIONS

- Multiplication, division, squaring
- Modulation/demodulation, phase detection
- Voltage-controlled amplifiers/attenuators/filters

## GENERAL DESCRIPTION

The AD633-EP is a functionally complete, four-quadrant, analog multiplier. It includes high impedance, differential X and Y inputs, and a high impedance summing input (Z). The low impedance output voltage is a nominal 10 V full scale provided by a buried Zener.

The AD633-EP is laser calibrated to a guaranteed total accuracy of 2% of full scale. Nonlinearity for the Y input is typically less than 0.1% and noise referred to the output is typically less than 100  $\mu\text{V}$  rms in a 10 Hz to 10 kHz bandwidth. A 1 MHz bandwidth, 20 V/ $\mu\text{s}$  slew rate, and the ability to drive capacitive loads make the AD633-EP useful in a wide variety of applications where simplicity and cost are key concerns.

The versatility of the AD633-EP is not compromised by its simplicity. The Z input provides access to the output buffer amplifier, enabling the user to sum the outputs of two or more multipliers, increase the multiplier gain, convert the output voltage to a current, and configure a variety of applications. For further information, see the [Multiplier Application Guide](#).

## FUNCTIONAL BLOCK DIAGRAM

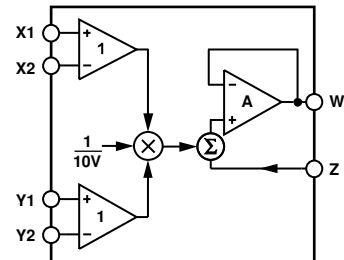

Figure 1.

The AD633-EP is available in an 8-lead SOIC package. It is specified to operate over the  $-55^{\circ}\text{C}$  to  $+125^{\circ}\text{C}$  military temperature range.

Additional application and technical information can be found in the [AD633](#) data sheet.

## PRODUCT HIGHLIGHTS

1. The AD633-EP is a complete four-quadrant multiplier offered in a low cost 8-lead SOIC package. The result is a product that is cost effective and easy to apply.
2. No external components or expensive user calibration are required to apply the AD633-EP.
3. Monolithic construction and laser calibration make the device stable and reliable.
4. High (10 M $\Omega$ ) input resistances make signal source loading negligible.
5. Power supply voltages can range from  $\pm 8$  V to  $\pm 18$  V. The internal scaling voltage is generated by a stable Zener diode; multiplier accuracy is essentially supply insensitive.

Rev. B

[Document Feedback](#)

Information furnished by Analog Devices is believed to be accurate and reliable. However, no responsibility is assumed by Analog Devices for its use, nor for any infringements of patents or other rights of third parties that may result from its use. Specifications subject to change without notice. No license is granted by implication or otherwise under any patent or patent rights of Analog Devices. Trademarks and registered trademarks are the property of their respective owners.

## TABLE OF CONTENTS

Features .....	1	Absolute Maximum Ratings .....	4
Enhanced Product Features .....	1	Thermal Resistance .....	4
Applications.....	1	Power Derating Curve .....	4
Functional Block Diagram .....	1	ESD Caution.....	4
General Description .....	1	Pin Configuration and Function Descriptions.....	5
Product Highlights .....	1	Typical Performance Characteristics .....	6
Revision History .....	2	Outline Dimensions .....	7
Specifications.....	3	Ordering Guide .....	7

## REVISION HISTORY

### 6/2018—Rev. A to Rev. B

Changes to Figure 3.....	5
--------------------------	---

### 1/2018—Rev. 0 to Rev. A

Changes to Thermal Resistance Section, Table 3, and Figure 2.....	4
Changes to Endnote 1, Table 3.....	4
Added Endnote 2, Table 3 .....	4

### 12/2017—Revision 0: Initial Version

## SPECIFICATIONS

$T_A = 25^\circ\text{C}$ ,  $V_S = \pm 15\text{ V}$ ,  $R_L \geq 2\text{ k}\Omega$ .

Table 1.

Parameter	Conditions	Min	Typ	Max	Unit
TRANSFER FUNCTION		$W = \frac{(X1 - X2)(Y1 - Y2)}{10\text{ V}} + Z$			
MULTIPLIER PERFORMANCE					
Total Error	$-10\text{ V} \leq X, Y \leq +10\text{ V}$		$\pm 1$	$\pm 2$	% full scale
$T_{\text{MIN}}$ to $T_{\text{MAX}}$			$\pm 3$		% full scale
Scale Voltage Error	SF = 10.00 V nominal		$\pm 0.25\%$		% full scale
Supply Rejection	$V_S = \pm 14\text{ V}$ to $\pm 16\text{ V}$		$\pm 0.01$		% full scale
Nonlinearity, X	$X = \pm 10\text{ V}$ , $Y = +10\text{ V}$		$\pm 0.4$	$\pm 1$	% full scale
Nonlinearity, Y	$Y = \pm 10\text{ V}$ , $X = +10\text{ V}$		$\pm 0.1$	$\pm 0.4$	% full scale
X Feedthrough	Y nulled, $X = \pm 10\text{ V}$		$\pm 0.3$	$\pm 1$	% full scale
Y Feedthrough	X nulled, $Y = \pm 10\text{ V}$		$\pm 0.1$	$\pm 0.4$	% full scale
Output Offset Voltage <sup>1</sup>			$\pm 5$	$\pm 50$	mV
DYNAMICS					
Small Signal Bandwidth	$V_O = 0.1\text{ V rms}$		1		MHz
Slew Rate	$V_O = 20\text{ V p-p}$		20		V/ $\mu\text{s}$
Settling Time to 1%	$\Delta V_O = 20\text{ V}$		2		$\mu\text{s}$
OUTPUT NOISE					
Spectral Density			0.8		$\mu\text{V}/\sqrt{\text{Hz}}$
Wideband Noise	$f = 10\text{ Hz}$ to $5\text{ MHz}$		1		mV rms
	$f = 10\text{ Hz}$ to $10\text{ kHz}$		90		$\mu\text{V rms}$
OUTPUT					
Output Voltage Swing		$\pm 11$			V
Short Circuit Current	$R_L = 0\ \Omega$		30	40	mA
INPUT AMPLIFIERS					
Signal Voltage Range	Differential	$\pm 10$			V
	Common mode	$\pm 10$			V
Offset Voltage (X, Y)			$\pm 5$	$\pm 30$	mV
CMRR (X, Y)	$V_{\text{CM}} = \pm 10\text{ V}$ , $f = 50\text{ Hz}$	60	80		dB
Bias Current (X, Y, Z)			0.8	2.0	$\mu\text{A}$
Differential Resistance			10		M $\Omega$
POWER SUPPLY					
Supply Voltage			$\pm 15$		V
Rated Performance					V
Operating Range		$\pm 8$		$\pm 18$	V
Supply Current	Quiescent		4	6	mA

<sup>1</sup> Allow approximately 0.5 ms for settling following power on.

## ABSOLUTE MAXIMUM RATINGS

Table 2.

Parameter	Rating
Supply Voltage	±18 V
Internal Power Dissipation	See Figure 2
Input Voltages <sup>1</sup>	±18 V
Output Short-Circuit Duration	Indefinite
Storage Temperature Range	−65°C to +150°C
Operating Temperature Range	−55°C to +125°C
Junction Temperature	150°C
Lead Temperature (Soldering, 60 sec)	260°C
ESD Rating	1000 V

<sup>1</sup> For supply voltages less than ±18 V, the absolute maximum input voltage is equal to the supply voltage.

Stresses at or above those listed under Absolute Maximum Ratings may cause permanent damage to the product. This is a stress rating only; functional operation of the product at these or any other conditions above those indicated in the operational section of this specification is not implied. Operation beyond the maximum operating conditions for extended periods may affect product reliability.

## THERMAL RESISTANCE

Thermal performance is directly linked to printed circuit board (PCB) design and operating environment. Careful attention to PCB thermal design is required.

Table 3.

Package Type	$\theta_{JA}$ <sup>1</sup>	$\theta_{JC}$ <sup>2</sup>	Unit
R-8	123.9	42.8	°C/W

<sup>1</sup> Test Condition 1: Thermal impedance simulated values are based on JEDEC 252P thermal test board. See JEDEC JESD51.

<sup>2</sup> Test Condition 2: Thermal impedance simulate values are based on JEDEC 150P thermal test board. See JEDEC JESD51.

## POWER DERATING CURVE

Figure 2 shows the maximum power dissipation vs. the ambient temperature.

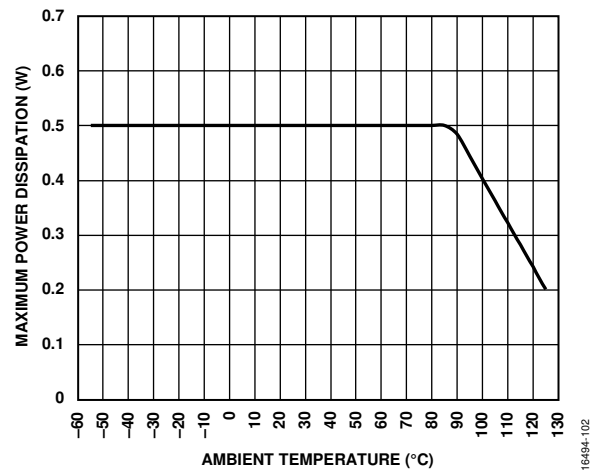

Figure 2. Maximum Power Dissipation vs. Ambient Temperature ( $T_A$ )

## ESD CAUTION



**ESD (electrostatic discharge) sensitive device.** Charged devices and circuit boards can discharge without detection. Although this product features patented or proprietary protection circuitry, damage may occur on devices subjected to high energy ESD. Therefore, proper ESD precautions should be taken to avoid performance degradation or loss of functionality.

### PIN CONFIGURATION AND FUNCTION DESCRIPTIONS

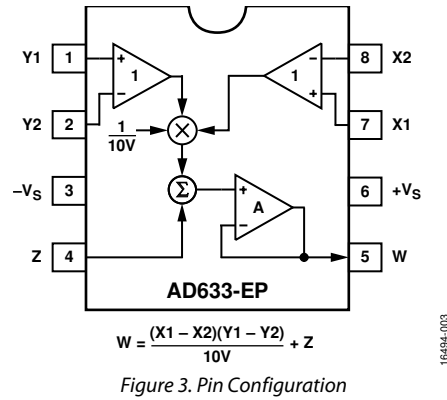

**Table 4. Pin Function Descriptions**

Pin No.	Mnemonic	Description
1	Y1	Y Multiplicand Noninverting Input
2	Y2	Y Multiplicand Inverting Input
3	-Vs	Negative Supply Rail
4	Z	Summing Input
5	W	Product Output
6	+Vs	Positive Supply Rail
7	X1	X Multiplicand Noninverting Input
8	X2	X Multiplicand Inverting Input

### TYPICAL PERFORMANCE CHARACTERISTICS

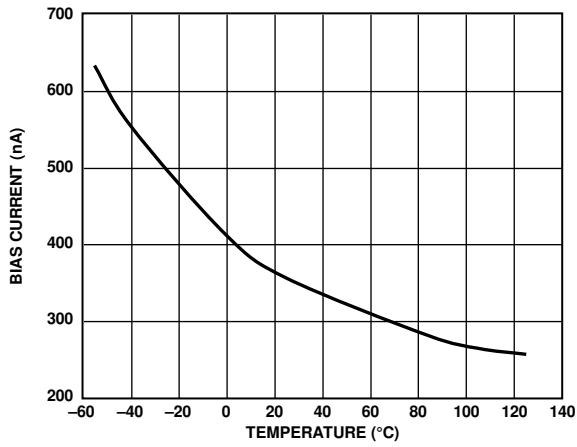
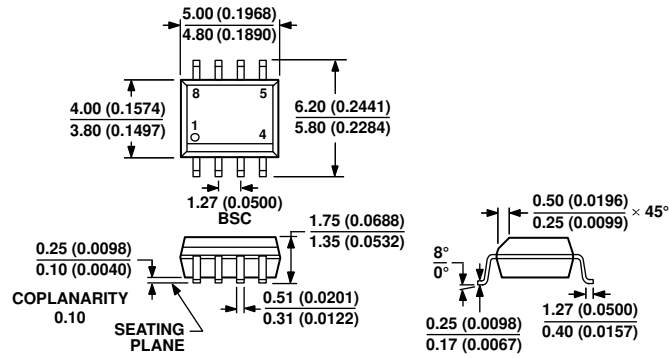

Figure 4. Input Bias Current vs. Temperature (X, Y, or Z Inputs)

16494-005

# OUTLINE DIMENSIONS



COMPLIANT TO JEDEC STANDARDS MS-012-AA  
 CONTROLLING DIMENSIONS ARE IN MILLIMETERS; INCH DIMENSIONS  
 (IN PARENTHESES) ARE ROUNDED-OFF MILLIMETER EQUIVALENTS FOR  
 REFERENCE ONLY AND ARE NOT APPROPRIATE FOR USE IN DESIGN.

0 12 407-A

Figure 5. 8-Lead Standard Small Outline Package [SOIC\_N]  
 Narrow Body  
 (R-8)

Dimensions shown in millimeters and (inches)

## ORDERING GUIDE

Model <sup>1</sup>	Temperature Range	Package Description	Package Option
AD633TRZ-EP	-55°C to +125°C	8-Lead Standard Small Outline Package [SOIC_N]	R-8
AD633TRZ-EP-R7	-55°C to +125°C	8-Lead Standard Small Outline Package [SOIC_N]	R-8

<sup>1</sup> Z = RoHS Compliant Part.