

2~4cell Li-ion/Li-polymer battery Secondary protection IC

## MM3508A Series

### Description

The MM3508A series is a double protection IC for 2-4 cell Li batteries. It detects battery voltage for each cell. The configuration of delay time can be achieved. Output at the time of detection can be held for a fixed period of time; therefore, this can maintain a regular disconnection time of a fuse. In addition, high cell voltage can be dropped and then stopped at the level where battery deterioration does not occur by Electrical discharge function of the IC after disconnecting the fuse. The ultra-small package SSON-6A is used to minimize footprints.

### Features

(Unless otherwise specified, Ta=25 degC)

Detection voltage	Range	Accuracy
Overcharge detection voltage	4.0V to 4.5V, 5mV steps	+/-20mV(Ta=0 to +50 degC)
Overcharge hysteresis voltage	50mV to 500mV, 50mV steps	+/-100mV

•Low current consumption

Typ. 3.5uA Max. 5.0uA (Vcell=4.0V)

Typ. 0.15uA Max. 0.30uA (Vcell=2.3V)

The FUSE cutting signal is the output between period of time. And the CELL voltage is released by electric discharge resistance of "60KΩ" after FUSE was cut.

And CELL stops an electric discharge if the CELL voltage becomes less than the electric discharge release voltage.

### Applications

- Lithium-ion rechargeable battery pack
- Lithium polymer rechargeable battery pack

### Package type

•SSON-6A	2.00 × 1.80 × 0.75 [mm]
•SOT-26A	2.90 × 2.80 × 1.15 [mm]

2~4cell Li-ion/Li-polymer battery Secondary protection IC

## MM3508B Series

### Description

The MM3508B series is a double protection IC for 2-4 cell Li batteries. It detects battery voltage for each cell. The configuration of delay time can be achieved. Output at the time of detection can be held for a fixed period of time; therefore, this can maintain a regular disconnection time of a fuse. In addition, high cell voltage can be dropped and then stopped at the level where battery deterioration does not occur by Electrical discharge function of the IC after disconnecting the fuse. The ultra-small package SSON-6A is used to minimize footprints.

### Features

(Unless otherwise specified, Ta=25 degC)

• Detection voltage	Range	Accuracy
Overcharge detection voltage	4.0V to 4.5V, 5mV steps	+/-20mV(Ta=0 to +50 degC)
Overcharge hysteresis voltage	50mV to 500mV, 50mV steps	+/-100mV
• Low current consumption		
Typ. 3.5uA Max. 5.0uA (Vcell=4.0V)		
Typ. 0.15uA Max. 0.30uA (Vcell=2.3V)		

### Applications

- Lithium-ion rechargeable battery pack
- Lithium polymer rechargeable battery pack

### Package type

• SSON-6A	2.00 × 1.80 × 0.75 [mm]
• SOT-26A	2.90 × 2.80 × 1.15 [mm]

2~3cell Li-ion/Li-polymer battery Secondary protection IC

## MM3508C Series

### Description

The MM3508C series is a double protection IC for 2-3 cell Li batteries. It detects battery voltage for each cell. The configuration of delay time can be achieved. Output at the time of detection can be held for a fixed period of time; therefore, this can maintain a regular disconnection time of a fuse. In addition, high cell voltage can be dropped and then stopped at the level where battery deterioration does not occur by Electrical discharge function of the IC after disconnecting the fuse. The ultra-small package SSON-6A is used to minimize footprints.

### Features

(Unless otherwise specified, Ta=25 degC)

Detection voltage	Range	Accuracy
Overcharge detection voltage	4.0V to 4.5V, 5mV steps	+/-20mV(Ta=0 to +50 degC)
Overcharge hysteresis voltage	50mV to 500mV, 50mV steps	+/-160mV
•Low current consumption		
	Typ. 3.5uA Max. 5.0uA (Vcell=4.0V)	
	Typ. 2.5uA Max. 4.0uA (Vcell=2.3V)	

The terminal CT is used to control the output voltage of the terminal OV. The terminal CT controls the output voltage of the terminal OV regardless of the overcharge detection circuit. As for the output voltage of the terminal OV, the terminal CT becomes usually state in "H", and it becomes "H" in Open or "L". The terminal OV is controlled with the overcharge detection circuit in usually state.

### Applications

- Lithium-ion rechargeable battery pack
- Lithium polymer rechargeable battery pack

### Package type

•SSON-6A	2.00 × 1.80 × 0.75 [mm]
•SOT-26A	2.90 × 2.80 × 1.15 [mm]

**Block diagram**

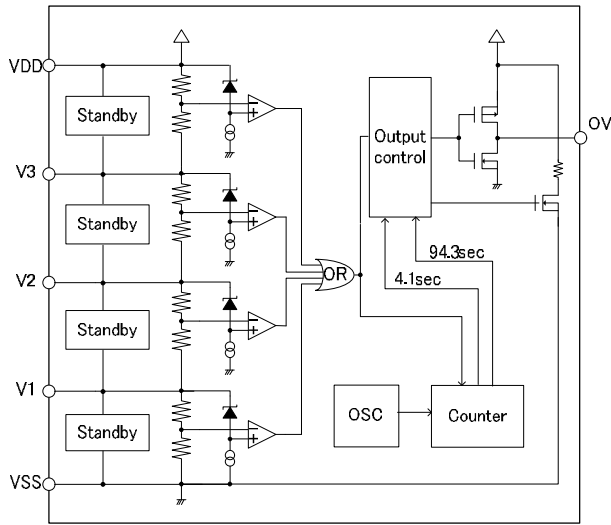

MM3508Axx rank

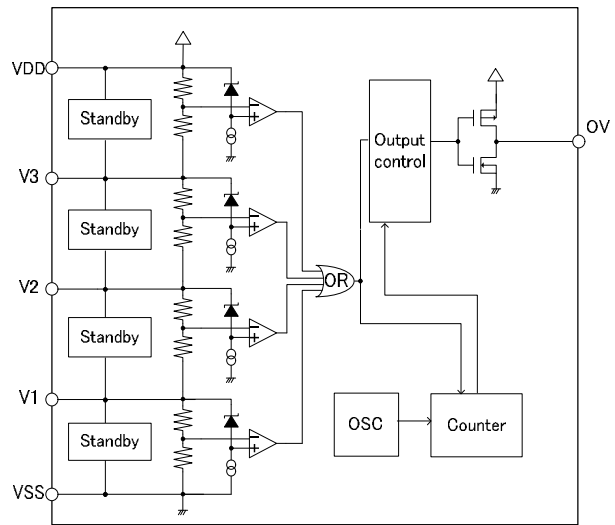

MM3508Bxx rank

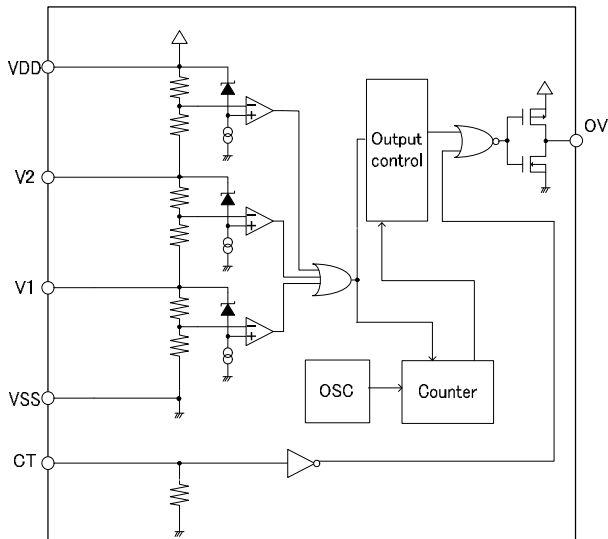

MM3508Cxx rank

**Package and pin configuration**

**Axx, Bxx rank**

SSON-6A	Pin No.	Symbol	Function
	1	VDD	input terminal of power supply of IC, and positive voltage of V4 cell
	2	V3	input terminal of positive voltage of V3 cell, and negative voltage of V4 cell
	3	V2	input terminal of positive voltage of V2 cell, and negative voltage of V3 cell
	4	V1	input terminal of positive voltage of V1 cell, and negative voltage of V2 cell
	5	VSS	input terminal of ground of IC, and negative voltage of V1 cell
	6	OV	Output of over charge detection Output type is CMOS

SOT-26A	Pin No.	Symbol	Function
	1	V2	input terminal of positive voltage of V2 cell, and negative voltage of V3 cell
	2	V3	input terminal of positive voltage of V3 cell, and negative voltage of V4 cell
	3	VDD	input terminal of power supply of IC, and positive voltage of V4 cell
	4	V1	input terminal of positive voltage of V1 cell, and negative voltage of V2 cell
	5	VSS	input terminal of ground of IC, and negative voltage of V1 cell
	6	OV	Output of over charge detection Output type is CMOS

**Cxx rank**

SSON-6A	Pin No.	Symbol	Function
	1	VDD	input terminal of power supply of IC, and positive voltage of V3 cell
	2	V2	input terminal of positive voltage of V2 cell, and negative voltage of V3 cell
	3	V1	input terminal of positive voltage of V1 cell, and negative voltage of V2 cell
	4	CT	input terminal of OV output control signal
	5	VSS	input terminal of ground of IC, and negative voltage of V1 cell
	6	OV	Output of over charge detection Output type is CMOS

SOT-26A	Pin No.	Symbol	Function
	1	V1	input terminal of positive voltage of V1 cell, and negative voltage of V2 cell
	2	V2	input terminal of positive voltage of V2 cell, and negative voltage of V3 cell
	3	VDD	input terminal of power supply of IC, and positive voltage of V3 cell
	4	OV	Output of over charge detection Output type is CMOS
	5	VSS	input terminal of ground of IC, and negative voltage of V1 cell
	6	CT	input terminal of OV output control signal

Package dimensions

Unit:mm

• SSON-6A

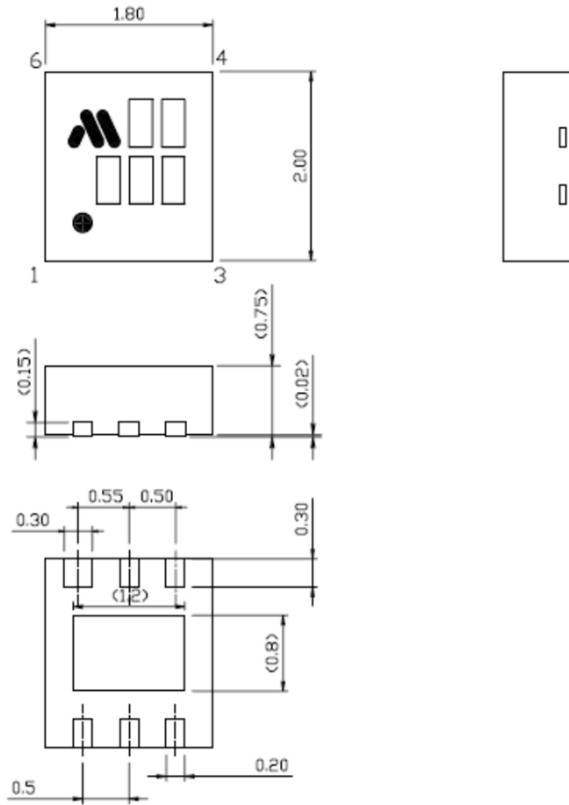

• SOT-26A

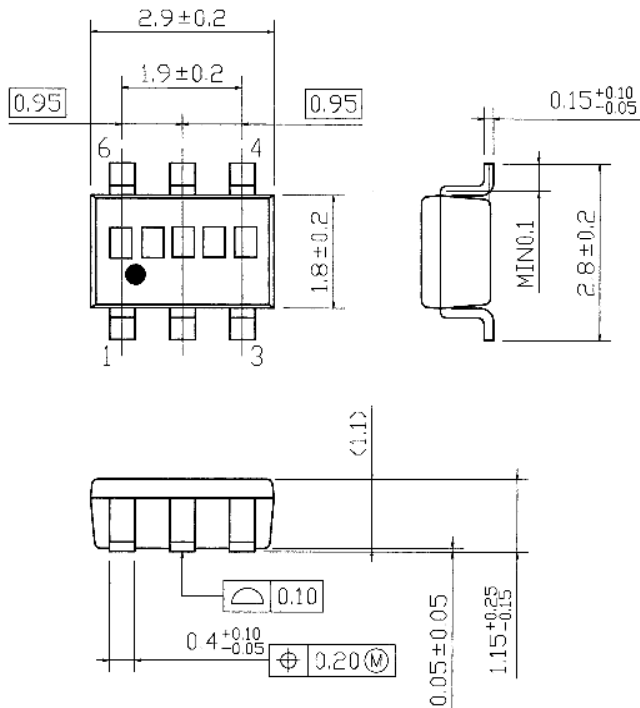

**Absolute maximum ratings**

**Axx, Bxx rank**

Parameter	Symbol	Rating	Unit
Supply voltage	VDD	VSS-0.3 to VSS+28	V
OV terminal	VO	VSS-0.3 to VDD+0.3	V
Storage temperature	Tstg	-55 to +125	degC
Power Dissipation	Pd	150	mV

**Cxx rank**

Parameter	Symbol	Rating	Unit
Supply voltage	VDD	VSS-0.3 to VSS+18	V
OV terminal	VO	VSS-0.3 to VDD+0.3	V
Storage temperature	Tstg	-55 to +125	degC
Power Dissipation	Pd	150	mV

**Recommend operating conditions**

**Axx, Bxx rank**

Parameter	Symbol	Rating	Unit
Operating ambient temperature	Topr	-40 to +110	degC
Operating voltage	Vop	VSS+2.0 to VSS+21.0	V

**Cxx rank**

Parameter	Symbol	Rating	Unit
Operating ambient temperature	Topr	-40 to +110	degC
Operating voltage	Vop	VSS+2.0 to VSS+18.0	V

**Electrical characteristics**

PARAMETER	SYMBOL	TEST CONDITIONS	RANK	MIN	TYP	MAX	UNIT	
Consumption current 1	I <sub>DD1</sub>	VCELL=3.5V,IOUT=0mA	Axx	-	3.5	5.0	μA	A
			Bxx	-	3.0	5.0		
Consumption current 2	I <sub>DD2</sub>	VCELL=2.3V,IOUT=0mA	Axx	-	0.15	0.30	μA	A
			Bxx	-	2.5	4.0		
V3 pin input current	I <sub>V3</sub>	VCELL=3.5V	Axx	-300	-	300	nA	A
			Bxx					
			Cxx					
V2 pin input current	I <sub>V2</sub>	VCELL=3.5V	-	-300	-	300	nA	A
V1 pin input current	I <sub>V1</sub>	VCELL=3.5V	-	-300	-	300	nA	A

**Electrical characteristics**

(unless otherwise specified, Ta=25°C, VCELL=3.5V)

PARAMETER	SYMBOL	TEST CONDITIONS	RANK	MIN	TYP	MAX	UNIT
Overcharge detection voltage	V <sub>CELLU</sub>	Ta=0~+50°C *1 VCELL=3.5V→4.6V	Axx	typ. -20mV	4.220	typ. +20mV	V
			Bxx		4.350		
			Cxx		4.450		
Overcharge detection voltage	V <sub>CELLU</sub>	Ta=-10~+85°C *1 VCELL=3.5V→4.6V	A01	typ. -25mV	4.220	typ. +25mV	V
			A04		4.320		
			A05		4.370		
			A07		4.375		
			B10		4.400		
Overcharge detection voltage	V <sub>CELLU</sub>	Ta=-40~+85°C *1 VCELL=3.5V→4.6V	A02	typ. -50mV	4.350	typ. +50mV	V
			A03		4.450		
			A06		4.500		
			B01		4.450		
			B06		4.350		
			B07		4.300		
			B08		4.450		
			B09		4.500		
			C01		4.350		
			C02		4.350		
			C03		4.450		
			C04		4.450		
			VDD pin pull-down release voltage		V <sub>hys</sub>		
(V4 cell) Overcharge release voltage	V <sub>CELLO</sub>	VCELL=4.5V→3.5V	B01	V <sub>CELLU</sub>	V <sub>CELLU</sub>	V <sub>CELLU</sub>	V
				-	-	-	
				0.6	0.5	0.4	
			B06 B07 B08 B09 B10	V <sub>CELLU</sub>	V <sub>CELLU</sub>	V <sub>CELLU</sub>	V
				-	-	-	
				0.72	0.62	0.52	
				0.72	0.62	0.52	
			Cxx	V <sub>CELLU</sub>	V <sub>CELLU</sub>	V <sub>CELLU</sub>	V
				-	-	-	
			0.55	0.39	0.23		
(V1,V2,V3 cell) Overcharge release voltage	V <sub>CELLO</sub>	VCELL=4.5V→3.5V	B06 B07	V <sub>CELLU</sub>	V <sub>CELLU</sub>	V <sub>CELLU</sub>	V
				-	-	-	
			B08 B09 B10	-	-	-	
				0.37	0.27	0.17	
				0.37	0.27	0.17	
Standby Voltage	V <sub>st</sub>	V1CELL=V2LCELL =V3CELL=V4CELL =4.5V→1.0V	Axx	2.60	3.20	3.80	V
			Bxx	2.50	3.10	3.70	V

\*1:guaranteed by design.



**Electrical characteristics**

(unless otherwise specified, Ta=25°C, VCELL=3.5V)

PARAMETER	SYMBOL	TEST CONDITIONS	RANK	MIN	TYP	MAX	UNIT
Overcharge detection voltage	V <sub>CELLU</sub>	Ta=0~+50°C *1 VCELL=3.5V→4.6V	Axx	typ. -20mV	4.220	typ. +20mV	V
			Bxx		4.350		
			Cxx		4.450		
Overcharge detection voltage	V <sub>CELLU</sub>	Ta=-10~+85°C *1 VCELL=3.5V→4.6V	A01	typ. -25mV	4.220	typ. +25mV	V
			A04		4.320		
			A05		4.370		
			A07		4.375		
			B10		4.400		
Overcharge detection voltage	V <sub>CELLU</sub>	Ta=-40~+85°C *1 VCELL=3.5V→4.6V	A02	typ. -50mV	4.350	typ. +50mV	V
			A03		4.450		
			A06		4.500		
			B01		4.450		
			B06		4.350		
			B07		4.300		
			B08		4.450		
			B09		4.500		
			C01		4.350		
			C02		4.350		
			C03		4.450		
			C04		4.450		
			VDD pin pull-down release voltage		V <sub>hys</sub>		
(V4 cell) Overcharge release voltage	V <sub>CELLO</sub>	VCELL=4.5V→3.5V	B01	V <sub>CELLU</sub>	V <sub>CELLU</sub>	V <sub>CELLU</sub>	V
				-	-	-	
				0.6	0.5	0.4	
			B06 B07 B08 B09 B10	V <sub>CELLU</sub>	V <sub>CELLU</sub>	V <sub>CELLU</sub>	V
				-	-	-	
				0.72	0.62	0.52	
				0.72	0.62	0.52	
			Cxx	V <sub>CELLU</sub>	V <sub>CELLU</sub>	V <sub>CELLU</sub>	V
-	-	-					
0.55	0.39	0.23					
(V1,V2,V3 cell) Overcharge release voltage	V <sub>CELLO</sub>	VCELL=4.5V→3.5V	B06 B07	V <sub>CELLU</sub>	V <sub>CELLU</sub>	V <sub>CELLU</sub>	V
				-	-	-	
			B08 B09 B10	-	-	-	
				0.37	0.27	0.17	
				0.37	0.27	0.17	
Standby Voltage	V <sub>st</sub>	V1CELL=V2LCELL =V3CELL=V4CELL =4.5V→1.0V	Axx	2.60	3.20	3.80	V
			Bxx	2.50	3.10	3.70	V

\*1:guaranteed by design.

**Typical application circuit**

**Axx, Bxx rank**

When using it for 4 cells

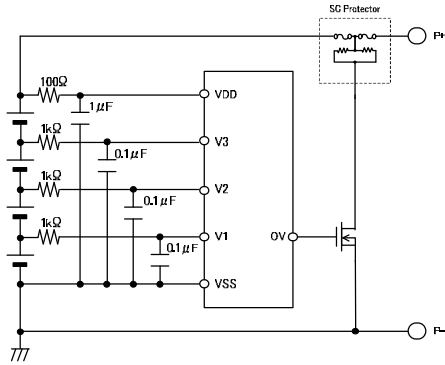
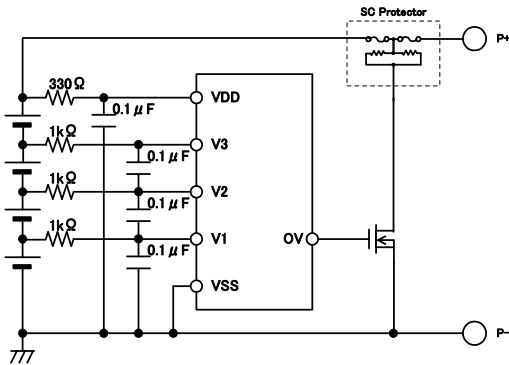

When using it for 3 cells

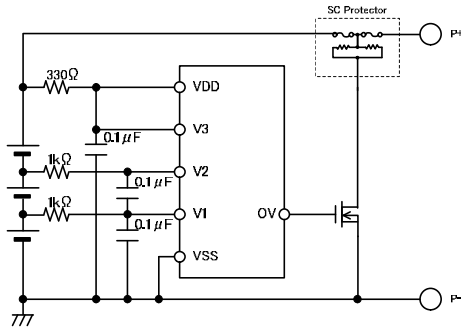
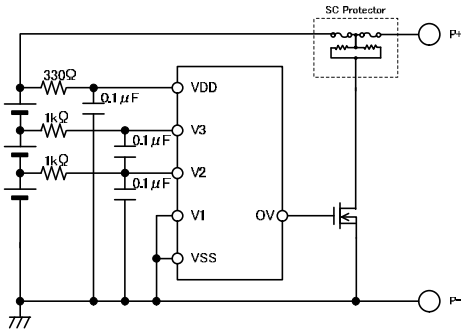

When using it for 2 cells

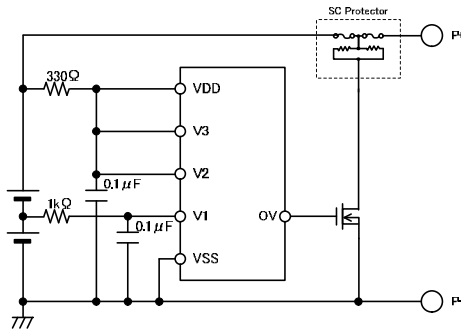
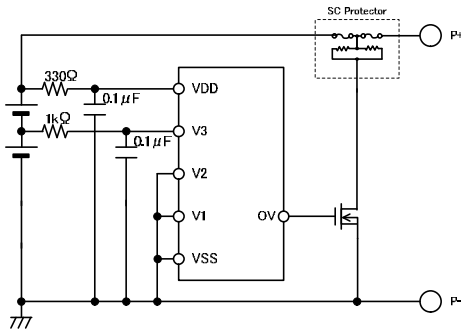

※1.The constant of the mark is a standard.

※2.The voltage change becomes big according to an excessive current, and the current of the bias in IC is turned off temporarily. It is this influence, and there is a possibility that the output logic becomes unstable. In that case, please set the time constant of CR connected with the power supply terminal so that the

**Typical application circuit**

**Cxx rank**

When using it for 3 cells

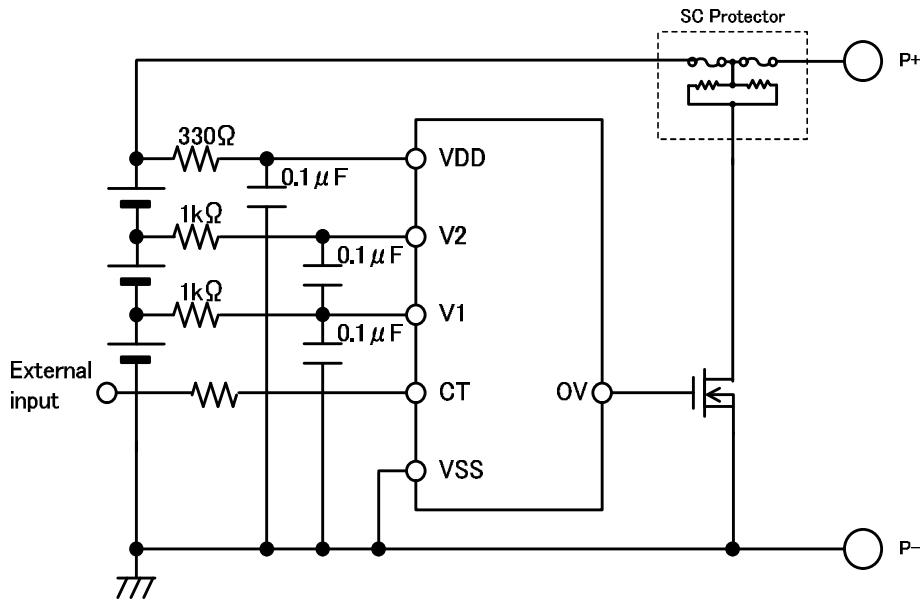

When using it by the overheat protection by PTC

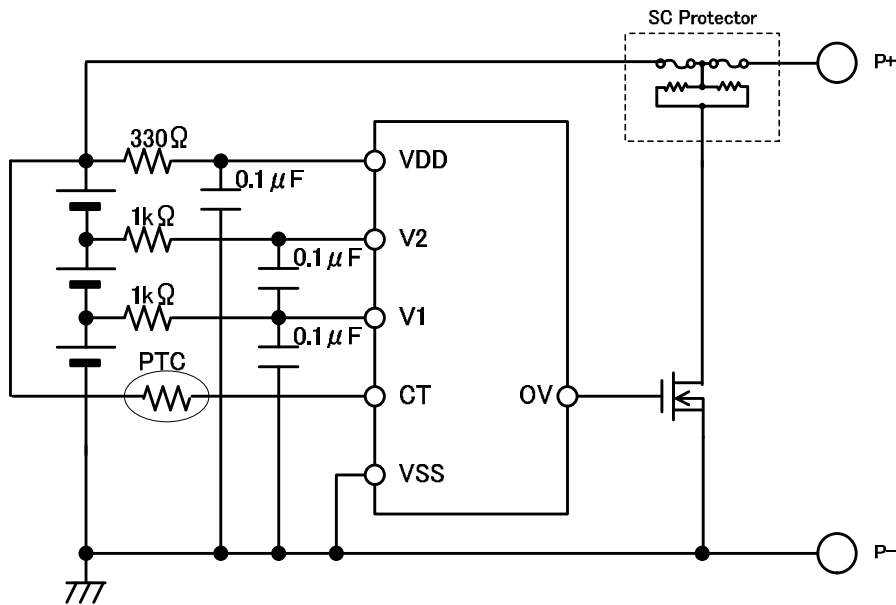

When connecting a battery, it is recommended to make a short circuit by connecting a jumper between the output and VSS and then remove the output jumper at the completion of installing all the cells.

**MODEL NAME**

M M 3 5 0 8 □ □ □ □ □ □						
		┌──────────┐ ┌┐ ┌┐ ┌┐				
		①		② ③ ④		
①	②	③		④		
rank	Package	Packing Specifications		Taping Material		
*1	N	SOT-26A	R	R HOUSING *Standard	H	Emboss tape / For Halogen free
	R	SSON-6A	L	L HOUSING	E	Emboss tape *2
			F	F HOUSING		
			B	B HOUSING		

\*1 Please refer to MODEL LIST.

\*2 SSON-6A corresponds to halogen free.

**MODEL LIST**

Parts Name	Overcharge detection voltage	Overcharge hysteresis voltage	Detection delay time	Latch function	Standby function	PTC function
① : ② : ③ : ④	$V_{CELLU}$	$V_{HYS}$	$T_{OV}$			
MM3508: A 0 1 : R : R : E	4.220±0.02V	500±100mV	4.10±0.9s	○	○	
MM3508: A 0 2 : R : R : E	4.350±0.02V	500±100mV	4.10±0.9s	○	○	
MM3508: A 0 3 : R : R : E	4.450±0.02V	500±100mV	4.10±0.9s	○	○	
MM3508: A 0 4 : R : R : E	4.320±0.02V	500±100mV	4.10±0.9s	○	○	
MM3508: A 0 5 : R : R : E	4.370±0.02V	500±100mV	4.10±0.9s	○	○	
MM3508: A 0 6 : R : R : E	4.500±0.02V	500±100mV	4.10±0.9s	○	○	
MM3508: A 0 7 : R : R : E	4.375±0.02V	500±100mV	4.10±0.9s	○	○	
MM3508: B 0 1 : R : R : E	4.450±0.02V	500±100mV	5.00±1.5s		○	
MM3508: B 0 6 : R : R : E	4.350±0.02V	V4 : 620±100mV V3~V1 : 270±100mV	4.00±1.2s		○	
MM3508: B 0 7 : R : R : E	4.300±0.02V	V4 : 620±100mV V3~V1 : 270±100mV	4.00±1.2s		○	
MM3508: B 0 8 : R : R : E	4.450±0.02V	V4 : 620±100mV V3~V1 : 270±100mV	4.00±1.2s		○	
MM3508: B 0 9 : R : R : E	4.500±0.02V	V4 : 620±100mV V3~V1 : 270±100mV	4.00±1.2s		○	
MM3508: B 1 0 : R : R : E	4.400±0.02V	V4 : 620±100mV V3~V1 : 270±100mV	4.50±1.35s		○	
MM3508: C 0 1 : R : R : E	4.350±0.02V	390±160mV	4.00±1.2s			○
MM3508: C 0 1 : N : R : H	4.350±0.02V	390±160mV	4.00±1.2s			○
MM3508: C 0 2 : R : R : E	4.350±0.02V	390±160mV	5.65±1.7s			○
MM3508: C 0 2 : N : R : H	4.350±0.02V	390±160mV	5.65±1.7s			○
MM3508: C 0 3 : R : R : E	4.450±0.02V	390±160mV	5.65±1.7s			○
MM3508: C 0 3 : N : R : H	4.450±0.02V	390±160mV	5.65±1.7s			○
MM3508: C 0 4 : R : R : E	4.450±0.02V	390±160mV	4.00±1.2s			○

## NOTES

### **【Safety Precautions】**

- Though Mitsumi Electric Co., Ltd. (hereinafter referred to as "Mitsumi") works continually to improve our product's quality and reliability, semiconductor products may generally malfunction or fail. Customers are responsible for complying with safety standards and for providing adequate designs and safeguards for their hardware, software and systems which minimize risk and avoid situations in which a malfunction or failure of this product could cause loss of human life, bodily injury, or damage to property, including data loss or corruption. Before customers use this product, create designs including this product, or incorporate this product into their own applications, customers must also refer to and comply with (a) the latest versions or all of our relevant information, including without limitation, product specifications, data sheets and application notes for this product and (b) the user's manual, handling instructions or all relevant information for any products which is to be used, or combined with this products. Customers are solely responsible for all aspects of their own product design or applications, including but not limited to (a) determining the appropriateness of the use of this product in such design or applications; (b) evaluating and determining the applicability of any information contained in this document, or in charts, diagrams, programs, algorithms, sample application circuits, or any other referenced documents; and (c) validating all operating parameters for such designs and applications. Mitsumi assumes no liability for customers' product design or applications.
- This product is intended for applying to computers, OA units, communication units, instrumentation units, machine tools, industrial robots, AV units, household electrical appliances, and other general electronic units.

### **【Precautions for Product Liability Act】**

- No responsibility is assumed by us for any consequence resulting from any wrong or improper use or operation, etc. of this product.

### **【ATTENTION】**

- This product is designed and manufactured with the intention of normal use in general electronics. No special circumstance as described below is considered for the use of it when it is designed. With this reason, any use and storage under the circumstances below may affect the performance of this product. Prior confirmation of performance and reliability is requested to customers.
  - Environment with strong static electricity or electromagnetic wave
  - Environment with high temperature or high humidity where dew condensation may occur
- This product is not designed to withstand radioactivity, and must avoid using in a radioactive environment.
- This specification is written in Japanese and English. The English text is faithfully translated into the Japanese. However, if any question arises, Japanese text shall prevail.