



## GENERAL DESCRIPTION



The ICS8701-01 is a low skew, ÷1, ÷2 LVCMOS/ LVTTTL Clock Generator. The low impedance LVCMOS outputs are designed to drive 50Ω series or parallel terminated transmission lines. The effective fanout can be increased from 20 to 40 by utilizing the ability of the outputs to drive two series terminated lines.

The divide select inputs, DIV\_SELx, control the output frequency of each bank. The outputs can be utilized in the ÷1, ÷2 or a combination of ÷1 and ÷2 modes. The master reset/output enable input, nMR/OE, resets the internal dividers and controls the active and high impedance states of all outputs. The output polarity inputs, INV0:1, control the polarity (inverting or non-inverting) of the outputs of each bank. Outputs QA0:QA4 are inverting for every combination of the INV0:1 input. The timing relationship between the inverting and non-inverting outputs at different frequencies is shown in the Timing Diagrams.

The ICS8701-01 is characterized at 3.3V and mixed 3.3V input supply, and 2.5V output supply operating modes. Guaranteed bank, output and part-to-part skew characteristics make the ICS8701-01 ideal for those clock distribution applications demanding well defined performance and repeatability.

## FEATURES

- Twenty LVCMOS/LVTTTL outputs, 7Ω typical output impedance
- One LVCMOS/LVTTTL clock input
- Maximum output frequency: 250MHz
- Selectable inverting and non-inverting outputs
- Bank enable logic allows unused banks to be disabled in reduced fanout applications
- Output skew: 300ps (maximum)
- Part-to-part skew: 700ps (maximum)
- Bank skew: 250ps (maximum)
- Multiple frequency skew: 350ps (maximum)
- 3.3V or mixed 3.3V input, 2.5V output operating supply
- 0°C to 70°C ambient operating temperature
- Available in both standard (RoHS 5) and lead-free (RoHS 6) packages

## BLOCK DIAGRAM

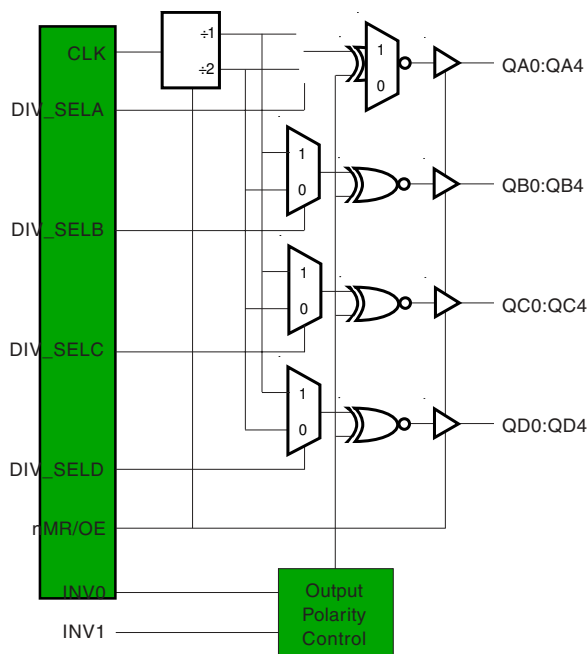

## PIN ASSIGNMENT

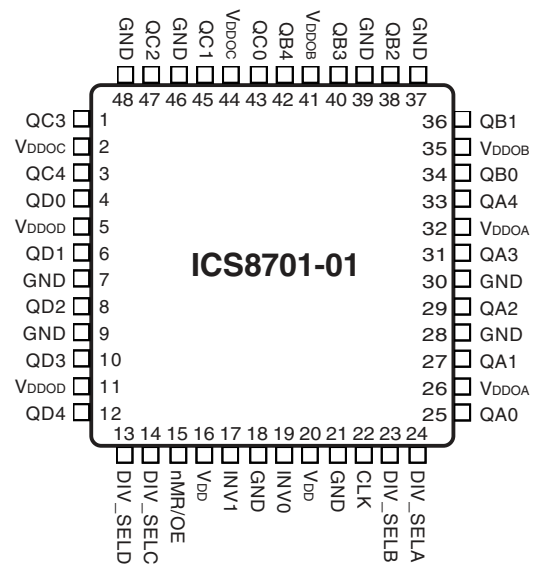

**48-Pin LQFP**  
7mm x 7mm x 1.4mm package body  
**Y Package**  
Top View

TABLE 1. PIN DESCRIPTIONS

Number	Name	Type		Description
1, 3, 43, 45, 47	QC3, QC4, QC0, QC1, QC2	Output		Bank C outputs. LVCMOS interface levels. 7Ω typical output impedance.
2, 44	V <sub>DDOC</sub>	Power		Output Bank C supply pins.
4, 6, 8, 10, 12	QD0, QD1, QD2, QD3, QD4	Output		Bank D outputs. LVCMOS interface levels. 7Ω typical output impedance.
5, 11	V <sub>DDOD</sub>	Power		Output Bank D supply pins.
7, 9, 18, 21, 28, 30, 37, 39, 46, 48	GND	Power		Power supply ground.
13	DIV_SELD	Input	Pullup	Controls frequency division for Bank D outputs. LVCMOS interface levels.
14	DIV_SEL C	Input	Pullup	Controls frequency division for Bank C outputs. LVCMOS interface levels.
15	nMR/OE	Input	Pullup	Master Reset and output enable. When HIGH, output drivers are enabled. When LOW, output drivers are in HiZ and dividers are reset. LVCMOS interface levels.
16, 20	V <sub>DD</sub>	Power		Power supply pins.
17, 19	INV1, INV0	Input	Pullup	Determines polarity of outputs by banks. LVCMOS interface levels.
22	CLK	Input	Pullup	LVCMOS clock input.
23	DIV_SEL B	Input	Pullup	Controls frequency division for Bank B outputs. LVCMOS interface levels.
24	DIV_SEL A	Input	Pullup	Controls frequency division for Bank A outputs. LVCMOS interface levels.
25, 27, 29, 31, 33	QA0, QA1, QA2, QA3, QA4	Output		Bank A outputs. LVCMOS interface levels. 7Ω typical output impedance.
26, 32	V <sub>DDOA</sub>	Power		Output Bank A supply pins.
34, 36, 38, 40, 42	QB0, QB1, QB2, QB3, QB4	Output		Bank B outputs. LVCMOS interface levels. 7Ω typical output impedance.
35, 41	V <sub>DDOB</sub>	Power		Output Bank B supply pins.

NOTE: Pullup refers to internal input resistors. See Table 2, Pin Characteristics, for typical values.

TABLE 2. PIN CHARACTERISTICS

Symbol	Parameter	Test Conditions	Minimum	Typical	Maximum	Units
C <sub>IN</sub>	Input Capacitance			4		pF
R <sub>PULLUP</sub>	Input Pullup Resistor			51		KΩ
C <sub>PD</sub>	Power Dissipation Capacitance (per output)	V <sub>DD</sub> , *V <sub>DDOx</sub> = 3.465			15	pF
R <sub>OUT</sub>	Output Impedance		5	7	12	Ω

\*NOTE: V<sub>DDOx</sub> denotes V<sub>DDOA</sub>, V<sub>DDOB</sub>, V<sub>DDOC</sub>, and V<sub>DDOD</sub>.

TABLE 3. FUNCTION TABLE

Inputs				Outputs				
nMR/OE	DIV_SELx	INV1	INV0	Bank A	Bank B	Bank C	Bank D	Qx Frequency
0	X	X	X	Hi Z	Hi Z	Hi Z	Hi Z	zero
1	0	0	0	Inverting	Non-inverting	Non-inverting	Non-inverting	fIN/2
1	0	0	1	Inverting	Inverting	Non-inverting	Non-inverting	fIN/2
1	0	1	0	Inverting	Inverting	Inverting	Non-inverting	fIN/2
1	0	1	1	Inverting	Inverting	Inverting	Inverting	fIN/2
1	1	0	0	Inverting	Non-inverting	Non-inverting	Non-inverting	fIN
1	1	0	1	Inverting	Inverting	Non-inverting	Non-inverting	fIN
1	1	1	0	Inverting	Inverting	Inverting	Non-inverting	fIN
1	1	1	1	Inverting	Inverting	Inverting	Inverting	fIN

**ABSOLUTE MAXIMUM RATINGS**

Supply Voltage, $V_{DD}$	4.6V
Inputs, $V_I$	-0.5V to $V_{DD} + 0.5$ V
Outputs, $V_O$	-0.5V to $V_{DDO} + 0.5$ V
Package Thermal Impedance, $\theta_{JA}$	47.9°C/W (0 lfpm)
Storage Temperature, $T_{STG}$	-65°C to 150°C

NOTE: Stresses beyond those listed under Absolute Maximum Ratings may cause permanent damage to the device. These ratings are stress specifications only. Functional operation of product at these conditions or any conditions beyond those listed in the *DC Characteristics* or *AC Characteristics* is not implied. Exposure to absolute maximum rating conditions for extended periods may affect product reliability.

**TABLE 4A. POWER SUPPLY DC CHARACTERISTICS,  $V_{DD} = 3.3V \pm 5\%$ ,  $V_{DDOx} = 3.3V \pm 5\%$  OR  $2.5V \pm 5\%$ ,  $T_A = 0^\circ\text{C}$  TO  $70^\circ\text{C}$** 

Symbol	Parameter	Test Conditions	Minimum	Typical	Maximum	Units
$V_{DD}$	Power Supply Voltage		3.135	3.3	3.465	V
$V_{DDOx}$	Output Supply Voltage; NOTE 1		3.135	3.3	3.465	V
			2.375	2.5	2.625	V
$I_{DD}$	Power Supply Current; NOTE 2				95	mA

NOTE 1:  $V_{DDOx}$  denotes  $V_{DDOx}$ ,  $V_{DDOx}$ ,  $V_{DDOx}$ , and  $V_{DDOx}$ .

NOTE 2:  $I_{DD}$  contributes 50mA;  $I_{DDOx}$  contributes 45mA.

**TABLE 4B. LVCMOS/LVTTTL DC CHARACTERISTICS,  $V_{DD} = 3.3V \pm 5\%$ ,  $V_{DDOx} = 3.3V \pm 5\%$  OR  $2.5V \pm 5\%$ ,  $T_A = 0^\circ\text{C}$  TO  $70^\circ\text{C}$** 

Symbol	Parameter	Test Conditions	Minimum	Typical	Maximum	Units
$V_{IH}$	Input High Voltage	DIV_SELA, DIV_SELB, DIV_SELc, DIV_SELd, INV0, INV1, nMR/OE	2		$V_{DD} + 0.3$	V
		CLK	2		$V_{DD} + 0.3$	V
$V_{IL}$	Input Low Voltage	DIV_SELA, DIV_SELB, DIV_SELc, DIV_SELd, INV0, INV1, nMR/OE	-0.3		0.8	V
		CLK	-0.3		1.3	V
$I_{IH}$	Input High Current	$V_{DD} = V_{IN} = 3.465V$ , $V_{DD} = V_{IN} = 2.625V$			5	$\mu\text{A}$
$I_{IL}$	Input Low Current	$V_{DD} = 3.465V$ , $V_{IN} = 0V$ , $V_{DD} = 2.625V$ , $V_{IN} = 0V$	-150			$\mu\text{A}$
$V_{OH}$	Output High Voltage; NOTE 1	$*V_{DDOx} = 3.465V$	2.6			V
		$*V_{DDOx} = 2.625V$	1.8			V
$V_{OL}$	Output Low Voltage; NOTE 1				0.5	V

NOTE 1: Outputs terminated with  $50\Omega$  to  $V_{DDOx}/2$ . See Parameter Measurement Information section, "3.3V Output Load Test Circuit".

\*NOTE:  $V_{DDOx}$  denotes  $V_{DDOx}$ ,  $V_{DDOx}$ ,  $V_{DDOx}$ ,  $V_{DDOx}$ .

**TABLE 5A. AC CHARACTERISTICS,  $V_{DD} = V_{DDOX} = 3.3V \pm 5\%$ ,  $T_A = 0^\circ C$  TO  $70^\circ C$** 

Symbol	Parameter	Test Conditions	Minimum	Typical	Maximum	Units
$f_{MAX}$	Output Frequency				250	MHz
$t_{PD}$	Propagation Delay; NOTE 1	$f \leq 200\text{MHz}$	2.0		3.5	ns
$t_{sk}(b)$	Bank Skew; NOTE 2, 7	Measured on the Falling Edge			250	ps
$t_{sk}(o)$	Output Skew; NOTE 3, 7	Measured on the Falling Edge			300	ps
$t_{sk}(w)$	Multiple Frequency Skew; NOTE 4, 7				350	ps
$t_{sk}(pp)$	Part to Part Skew; NOTE 5, 7				700	ps
$t_R$	Output Rise Time; NOTE 6	20% to 80%	150		700	ps
$t_F$	Output Fall Time; NOTE 6	20% to 80%	150		700	ps
$t_{PW}$	Output Pulse Width	$f \leq 200\text{MHz}$	$t_{Period}/2 - 0.5$	$t_{Period}/2$	$t_{Period}/2 + 0.5$	ns
		$f = 200\text{MHz}$	2	2.5	3	ns
$t_{EN}$	Output Enable Time; NOTE 6				6	ns
$t_{DIS}$	Output Disable Time; NOTE 6				6	ns

All parameters measured at 200MHz unless noted otherwise.

NOTE: Electrical parameters are guaranteed over the specified ambient operating temperature range, which is established when the device is mounted in a test socket with maintained transverse airflow greater than 500 lfpm. The device will meet specifications after thermal equilibrium has been reached under these conditions.

NOTE 1: Measured from the  $V_{DD}/2$  of the input to  $V_{DDOX}/2$  of the output.

NOTE 2: Defined as skew within a bank with equal load conditions.

NOTE 3: Defined as skew between outputs at the same supply voltage and with equal load conditions.

Measured at  $V_{DDOX}/2$ .

NOTE 4: Defined as skew across banks of outputs switching in the same direction operating at different frequencies with the same supply voltages and equal load conditions. Measured at  $V_{DDOX}/2$ .

NOTE 5: Defined as skew between outputs on different devices operating at the same supply voltage, same temperature and with equal load conditions. Using the same type of input on each device, the output is measured at  $V_{DDOX}/2$ .

NOTE 6: These parameters are guaranteed by characterization. Not tested in production.

NOTE 7: This parameter is defined in accordance with JEDEC Standard 65.

**TABLE 5A. AC CHARACTERISTICS,  $V_{DD} = V_{DDOX} = 3.3V \pm 5\%$ ,  $T_A = 0^\circ C$  TO  $70^\circ C$** 

Symbol	Parameter	Test Conditions	Minimum	Typical	Maximum	Units
$t_{sk}(inv)$	Inverting Skew; NOTE 1, 2	$f = 66.7\text{MHz}$			400	ps

NOTE: Electrical parameters are guaranteed over the specified ambient operating temperature range, which is established when the device is mounted in a test socket with maintained transverse airflow greater than 500 lfpm. The device will meet specifications after thermal equilibrium has been reached under these conditions.

NOTE 1: Defined as skew across banks of outputs switching in opposite directions operating at the same frequency with the same supply voltages and equal load conditions. Measured at  $V_{DDOX}/2$ .

NOTE 2: This parameter is defined in accordance with JEDEC Standard 65.

**TABLE 5B. AC CHARACTERISTICS,  $V_{DD} = 3.3V \pm 5\%$ ,  $V_{DDOX} = 2.5V \pm 5\%$ ,  $T_A = 0^\circ C$  TO  $70^\circ C$** 

Symbol	Parameter	Test Conditions	Minimum	Typical	Maximum	Units
$f_{MAX}$	Output Frequency				250	MHz
$t_{PD}$	Propagation Delay; NOTE 1	$f \leq 200MHz$	2.0		3.5	ns
$t_{sk}(b)$	Bank Skew; NOTE 2, 7	Measured on the Falling Edge			300	ps
$t_{sk}(o)$	Output Skew; NOTE 3, 7	Measured on the Falling Edge			300	ps
$t_{sk}(w)$	Multiple Frequency Skew; NOTE 4, 7				350	ps
$t_{sk}(pp)$	Part to Part Skew; NOTE 5, 7				700	ps
$t_R$	Output Rise Time; NOTE 6	20% to 80%	150		720	ps
$t_F$	Output Fall Time; NOTE 6	20% to 80%	150		720	ps
$t_{PW}$	Output Pulse Width	$f \leq 200MHz$	$t_{Period}/2 - 0.5$	$t_{Period}/2$	$t_{Period}/2 + 0.5$	ns
		$f = 200MHz$	2	2.5	3	ns
$t_{EN}$	Output Enable Time; NOTE 6				6	ns
$t_{DIS}$	Output Disable Time; NOTE 6				6	ns

All parameters measured at 200MHz unless noted otherwise.

NOTE: Electrical parameters are guaranteed over the specified ambient operating temperature range, which is established when the device is mounted in a test socket with maintained transverse airflow greater than 500 lfpm. The device will meet specifications after thermal equilibrium has been reached under these conditions.

NOTE 1: Measured from the  $V_{DD}/2$  of the input to  $V_{DDOX}/2$  of the output.

NOTE 2: Defined as skew within a bank with equal load conditions.

NOTE 3: Defined as skew between outputs at the same supply voltage and with equal load conditions.

Measured at  $V_{DDOX}/2$ .

NOTE 4: Defined as skew across banks of outputs switching in the same direction operating at different frequencies with the same supply voltages and equal load conditions. Measured at  $V_{DDOX}/2$ .

NOTE 5: Defined as skew between outputs on different devices operating at the same supply voltage, same temperature and with equal load conditions. Using the same type of input on each device, the output is measured at  $V_{DDOX}/2$ .

NOTE 6: These parameters are guaranteed by characterization. Not tested in production.

NOTE 7: This parameter is defined in accordance with JEDEC Standard 65.

# PARAMETER MEASUREMENT INFORMATION

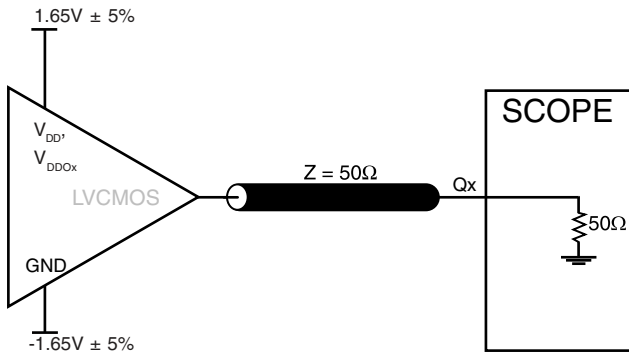

**3.3V CORE/3.3V OUTPUT LOAD AC TEST CIRCUIT**

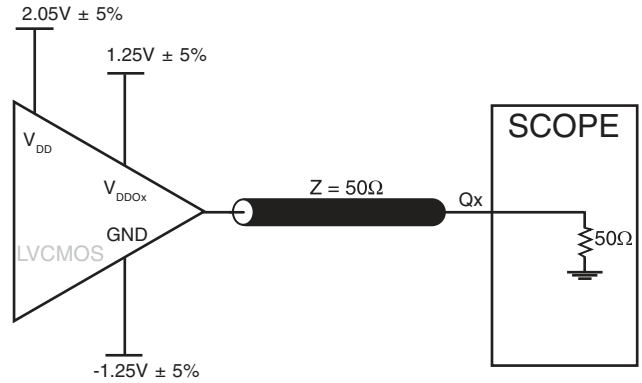

**3.3V CORE/2.5V OUTPUT LOAD AC TEST CIRCUIT**

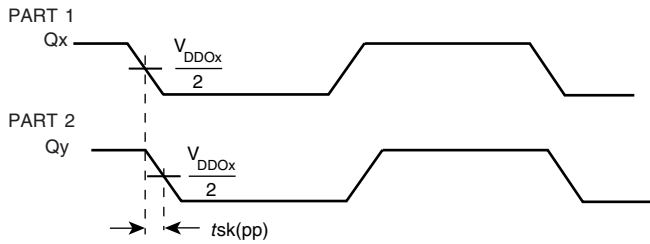

**PART-TO-PART SKEW**

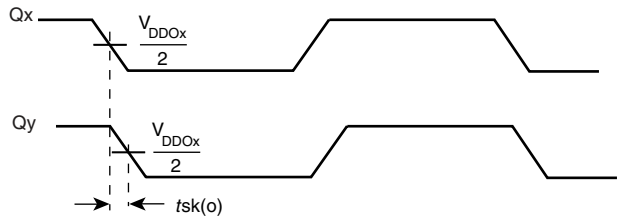

**OUTPUT SKEW**

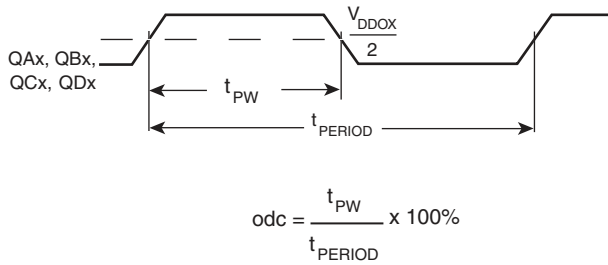

**OUTPUT DUTY CYCLE/PULSE WIDTH/PERIOD**

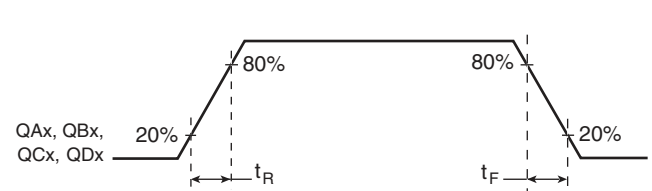

**OUTPUT RISE/FALL TIME**

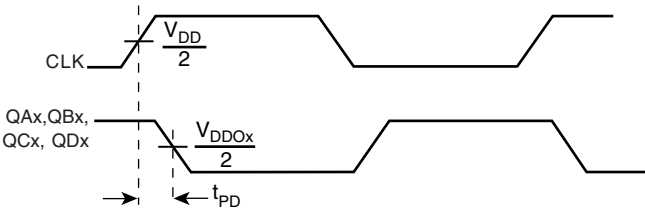

**PROPAGATION DELAY**

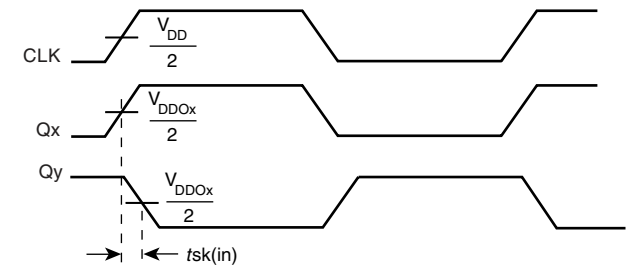

**INVERTING SKEW**

## RELIABILITY INFORMATION

TABLE 7.  $\theta_{JA}$  vs. AIR FLOW TABLE FOR 48 LEAD LQFP

$\theta_{JA}$ by Velocity (Linear Feet per Minute)			
	0	200	500
Single-Layer PCB, JEDEC Standard Test Boards	67.8°C/W	55.9°C/W	50.1°C/W
Multi-Layer PCB, JEDEC Standard Test Boards	47.9°C/W	42.1°C/W	39.4°C/W

**NOTE:** Most modern PCB designs use multi-layered boards. The data in the second row pertains to most designs.

### TRANSISTOR COUNT

The transistor count for ICS8701-01 is: 1819

**PACKAGE OUTLINE - Y SUFFIX FOR 48 LEAD LQFP**

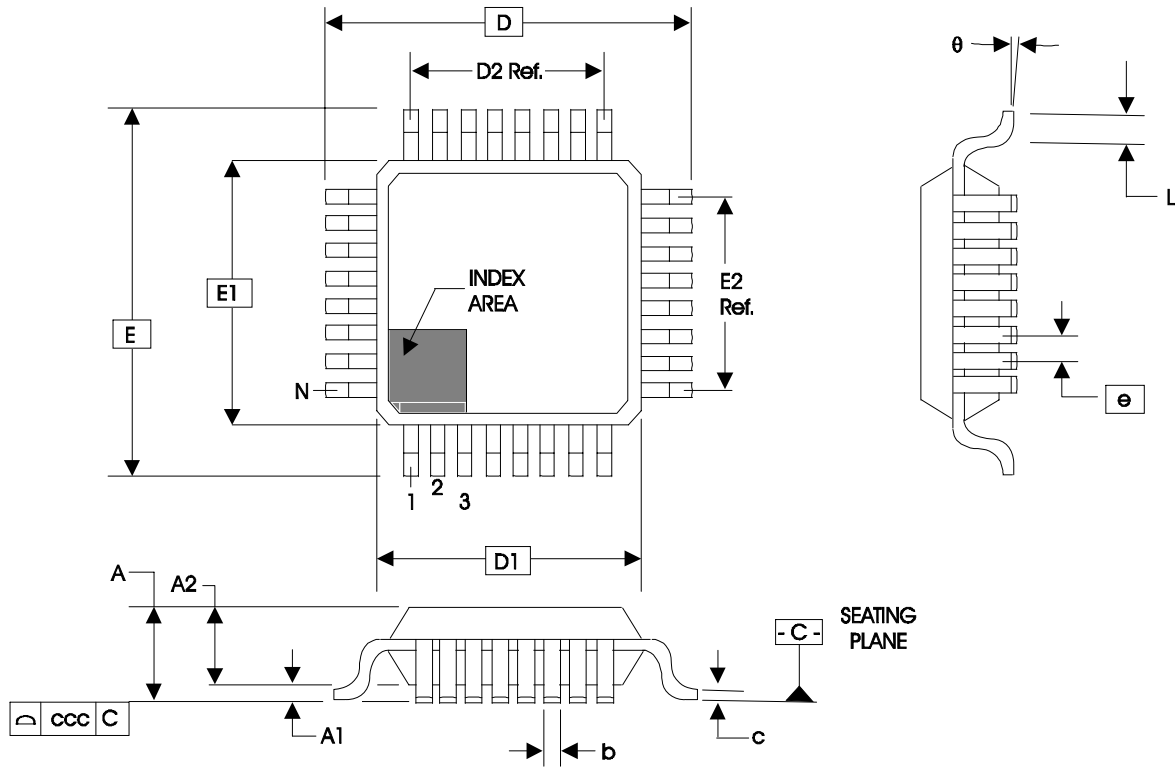

**TABLE 8. PACKAGE DIMENSIONS**

JEDEC VARIATION ALL DIMENSIONS IN MILLIMETERS			
SYMBOL	BBC		
	MINIMUM	NOMINAL	MAXIMUM
N	48		
A	--	--	1.60
A1	0.05	--	0.15
A2	1.35	1.40	1.45
b	0.17	0.22	0.27
c	0.09	--	0.20
D	9.00 BASIC		
D1	7.00 BASIC		
D2	5.50 Ref.		
E	9.00 BASIC		
E1	7.00 BASIC		
E2	5.50 Ref.		
e	0.50 BASIC		
L	0.45	0.60	0.75
$\theta$	0°	--	7°
ccc	--	--	0.08

Reference Document: JEDEC Publication 95, MS-026



**TABLE 9. ORDERING INFORMATION**

Part/Order Number	Marking	Package	Packaging	Temperature
8701AY-01	ICS8701AY-01	48 Lead LQFP	Tray	0°C to 70°C
8701AY-01T	ICS8701AY-01	48 Lead LQFP	1000 Tape & Reel	0°C to 70°C
8701AY-01LF	ICS8701AY01L	Lead-Free, 48 Lead LQFP	Tray	0°C to 70°C
8701AY-01LFT	ICS8701AY01L	Lead-Free, 48 Lead LQFP	1000 Tape & Reel	0°C to 70°C

While the information presented herein has been checked for both accuracy and reliability, Integrated Device Technology, Incorporated (IDT) assumes no responsibility for either its use or for infringement of any patents or other rights of third parties, which would result from its use. No other circuits, patents, or licenses are implied. This product is intended for use in normal commercial applications. Any other applications such as those requiring extended temperature ranges, high reliability or other extraordinary environmental requirements are not recommended without additional processing by IDT. IDT reserves the right to change any circuitry or specifications without notice. IDT does not authorize or warrant any IDT product for use in life support devices or critical medical instruments.

REVISION HISTORY SHEET				
Rev	Table	Page	Description of Change	Date
B	T4A & T4C	4 & 6	DC Characteristics tables revised. $I_{DD}$ row, value changed from 70mA Max. to 95mA Max.	8/1/01
B	T5A & T5B	5 & 7	AC Characteristics tables revised: $t_{PD}$ symbol (Propagation Delay row), changed to $tp_{HL}$ . Added test conditions to Bank and Output Skews. Revised notes.	8/7/01
B	T2 T5A & T5B	2 4 & 5	Pin Characteristics table, added 15pF Max. to $C_{PD}$ row. Revised notes in AC tables.	8/29/01
C	T5B	4	Added extra AC characteristics table to include Inverting Skew parameters.	2/8/02
C	T1	2	Pin Description Table, revised nMR/OE description.	8/21/02
D	T2	2	Pin Characteristics Table - changed $C_{IN}$ max. 4pF to 4pF typical. Added 5 $\Omega$ min. and 12 $\Omega$ max. to $R_{OUT}$ .	11/17/03
	T4A	3	Combined 3.3V and Mixed 3.3V/2.5V Power Supply Tables.	
	T4B	3	LVCMOS Table - changed $V_{IH}$ max. from 3.765V to $V_{DD} + 0.3V$ . Combined 3.3V and Mixed 3.3V/2.5V LVCMOS Tables.	
E	T5A & T5B	4 & 5 6	AC Characteristics Tables - deleted $tp_{HL}$ row. Changed $tp_{LH}$ to $t_{PD}$ . Updated format throughout data sheet.	12/15/03
	T5A & T5B	4 & 5 6	AC Characteristics Tables - changed $t_{PD}$ min. from 2.5ns to 2.0ns. Parameter Measurement Section - Propagation Delay Diagram, Qx should be inverted and measurement should be from rising edge of clk to falling edge of Qx. Output Skew and Part-to-Part Skew Diagram should be measured on falling edge. Added Inverting Skew Diagram.	
E	T5A & T5B T9	4 & 5 6 8 9	AC Characteristics Tables - added Thermal note. Updated Parameter Measurement Information section. Updated Package Outline. Ordering Information Table - deleted "ICS" prefix. Added lead-free marking.	3/2/10



6024 Silver Creek Valley Road  
San Jose, CA 95138

**Sales**

800-345-7015 (inside USA)  
+408-284-8200 (outside USA)  
Fax: 408-284-2775  
[www.IDT.com/go/contactIDT](http://www.IDT.com/go/contactIDT)

**Technical Support**

[netcom@idt.com](mailto:netcom@idt.com)  
+480-763-2056

DISCLAIMER Integrated Device Technology, Inc. (IDT) and its subsidiaries reserve the right to modify the products and/or specifications described herein at any time and at IDT's sole discretion. All information in this document, including descriptions of product features and performance, is subject to change without notice. Performance specifications and the operating parameters of the described products are determined in the independent state and are not guaranteed to perform the same way when installed in customer products. The information contained herein is provided without representation or warranty of any kind, whether express or implied, including, but not limited to, the suitability of IDT's products for any particular purpose, an implied warranty of merchantability, or non-infringement of the intellectual property rights of others. This document is presented only as a guide and does not convey any license under intellectual property rights of IDT or any third parties.

IDT's products are not intended for use in life support systems or similar devices where the failure or malfunction of an IDT product can be reasonably expected to significantly affect the health or safety of users. Anyone using an IDT product in such a manner does so at their own risk, absent an express, written agreement by IDT.

Integrated Device Technology, IDT and the IDT logo are registered trademarks of IDT. Other trademarks and service marks used herein, including protected names, logos and designs, are the property of IDT or their respective third party owners.

Copyright 2009. All rights reserved.