

REVISIONS			
REV	DESCRIPTION, ECN, EAR NO.	DATE	APP'D
A	PROPOSAL	MAY 25/06	L.CHAN
B	CHANGE SHIELD'S MATERIAL PER ECN 160658	JUN 14/16	L.CHAN
C	CHANGE SHIELD'S PCB TAIL PLATING	APR 19/17	L.CHAN

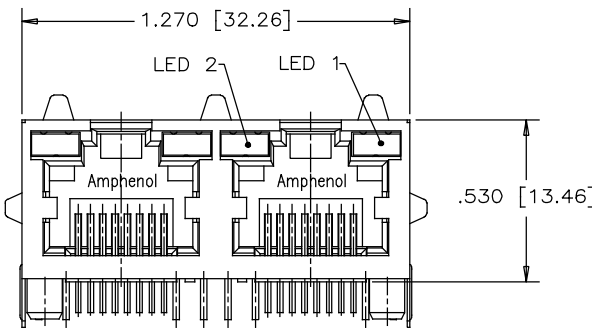

FRONT VIEW

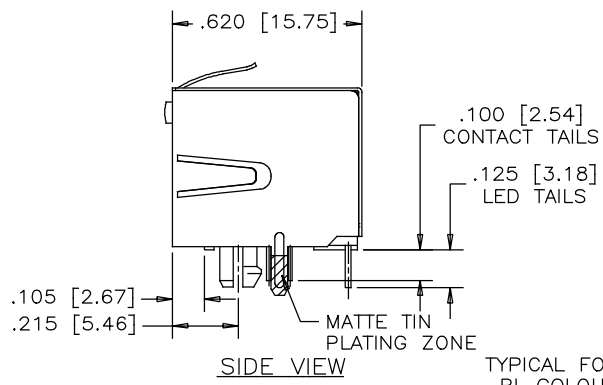

SIDE VIEW

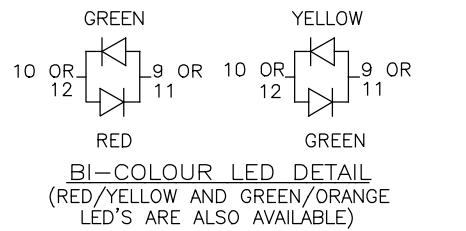

BI-COLOUR LED DETAIL
(RED/YELLOW AND GREEN/ORANGE LED'S ARE ALSO AVAILABLE)

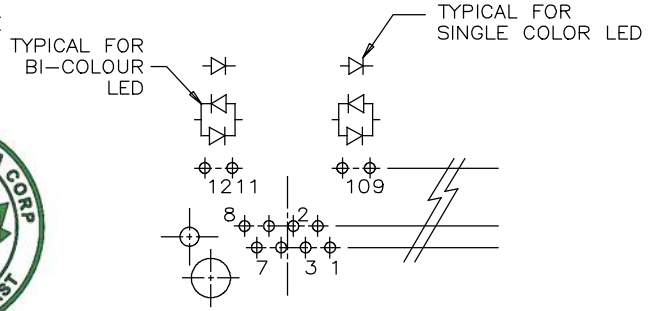

LED SCHEMATIC



MATERIALS:

PLASTIC HOUSING: HIGH TEMPERATURE THERMOPLASTIC
FLAMMABILITY RATING UL 94V-0, COLOUR: BLACK

CONTACTS: PHOSPHOR BRONZE
PLATING: GOLD ON MATING SURFACES

(SEE PART NO. FOR THICKNESS).
50 μ" [1.27 MICRONS]
MIN. NICKEL UNDERPLATE
100 μ" [2.54 MICRONS]
MIN. MATTE TIN ON CONTACT TAILS.

SHIELD: STAINLESS STEEL WITH MATTE TIN PLATING ON SOLDER TAIL.

RECOMMENDED SOLDERING TEMPERATURE:
WAVE SOLDERING AT 260°C MAXIMUM FOR 5 SEC MAXIMUM.

PART NUMBER: RJHSE-X38X-02

GOLD PLATING _____ REFER TO LED OPTIONS DRAWING FOR ORDERING CODES

E=RJ45 FLAT CONTACT 6u"
G=RJ45 FLAT CONTACT 15u"
J=RJ45 FLAT CONTACT 30u"
5=RJ45 FLAT CONTACT 50u"
0=RJ45 FLAT CONTACT 1u"

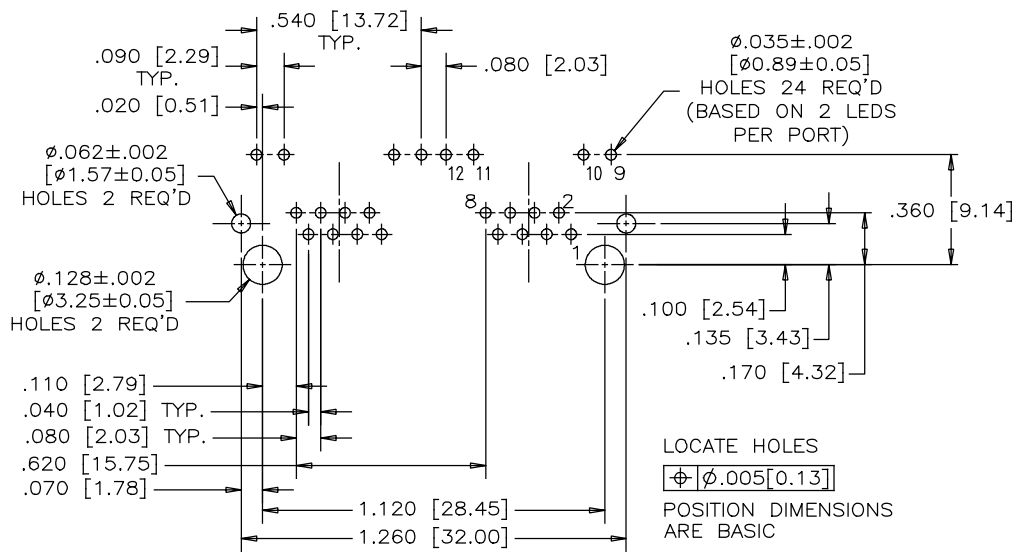

RECOMMENDED P.C.B. LAYOUT
(COMPONENT SIDE OF BOARD)

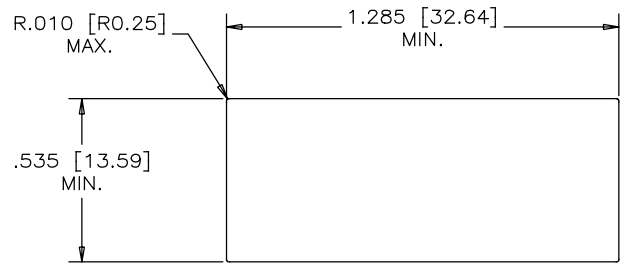

RECOMMENDED PANEL CUTOUT

LOCATE HOLES
[Ø] Ø.005 [0.13]
POSITION DIMENSIONS ARE BASIC

UNLESS SPECIFIED OTHERWISE	DRAWN PWANG	DATE MAY 25/06
PRIMARY UNITS INCH	CHECKED CHIGOW	MAY 25/06
SECONDARY MILLIMETER	M.E. APP'D	
REFERENCE IN PARENTHESES	Q.A. APP'D	
GENERAL TOLERANCES	DWG APPR.	
1 DECIMAL PLACE ±0.025	ENG. REL. NO.	
2 DECIMAL PLACES ±0.020	REF.	
3 DECIMAL PLACES ±0.015	THIRD ANGLE PROJECTION	DO NOT SCALE DRAWING
ANGULAR DEGREES ±1.0°		

Amphenol Canada Corp. www.amphenolcanada.com		
TITLE 2 PORT HIGH SPEED MODULAR JACK, 8 POSITION, 8 CONTACTS, SHIELDED AND WITH LED OPTIONS - RoHS COMPLIANT		
DWG. NO. P-RJHSE-X38X-02	REV C	
CODE ID NO. 03554	DWG SIZE: C	SCALE: N/A

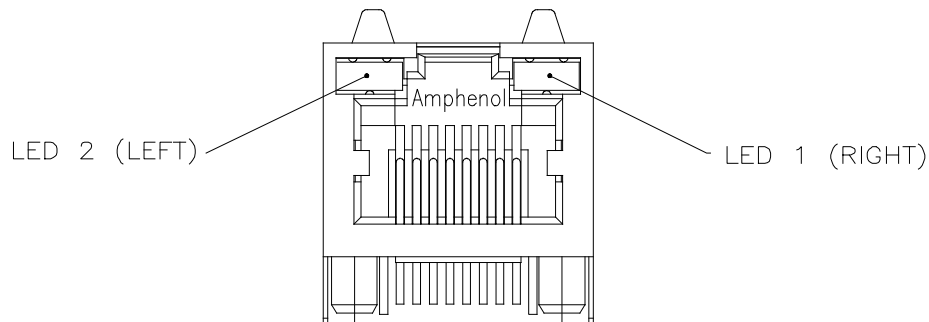

TYPICAL FOR SINGLE & MULTI-PORT



EXAMPLE:

PART NUMBER RJHSE-538X



LED COLOR CODE

CODE	LED 2 (LEFT)	LED 1 (RIGHT)	CODE	LED 2 (LEFT)	LED 1 (RIGHT)	CODE	LED 2 (LEFT)	LED 1 (RIGHT)
0	BLOCKED	BLOCKED	9	GREEN	BLOCKED	J	BiC RD/GR	YELLOW
1	YELLOW	GREEN	A	BiC GR/YE	BiC GR/YE	K	YELLOW	BiC GR/OR
2	BLOCKED	GREEN	B	BiC RD/GR	BiC RD/GR	L	BiC GR/YE	RED
3	YELLOW	BLOCKED	C	BiC RD/GR	BiC GR/YE	M	RED	YELLOW
4	GREEN	YELLOW	D	GREEN	BiC GR/YE	N	BiC GR/RD	BiC GR/YE
5	GREEN	GREEN	E	YELLOW	BiC GR/YE	P	GREEN	BiC RD/GR
6	YELLOW	YELLOW	F	BiC GR/YE	YELLOW	R	BiC GR/OR	GREEN
7	RED	GREEN	G	BiC GR/OR	BiC GR/OR	T	RED	RED
8	GREEN	RED	H	BiC GR/YE	GREEN	V	BiC RD/GR	GREEN
						W	ADDITIONAL	OPTIONS

EXAMPLE OF ADDITIONAL LED OPTIONS:

PART NUMBER RJHSE-538W-01Y



ADDITIONAL LED COLOR CODE
DENOTES ADDITIONAL LED OPTIONS TO BE USED

CODE	LED 2 (LEFT)	LED 1 (RIGHT)	CODE	LED 2 (LEFT)	LED 1 (RIGHT)	CODE	LED 2 (LEFT)	LED 1 (RIGHT)
0	DO NOT USE		5	BLOCKED	YELLOW	E	BiC GR/YE	BiC GR/RD
1	RED	BLOCKED	6	RED	BiC RD/GR	A	LOWC YE	LOWC YE
2	BiC GR/OR	YELLOW	7	BLOCKED	BiC RD/GR	B	LOWC YE	LOWC GR
3	YELLOW	RED	8	BiC RD/GR	BLOCKED	C	LOWC GR	LOWC YE
4	BLOCKED	RED	9	BiC GR/YE	BLOCKED	D	LOWC GR	LOWC GR
			N	BLUE	RED	M	LOWC RD	LOWC YE

REVISIONS				
SYM	ZONE	ECN, ERN NO.	DATE	APPRD.
B		ADD LED CODE N	AUG16/12	L.C
C		UPDATE RoHS STAMP	AUG30/13	L.C
D		UPDATE SPEC.	MAY07/14	L.C
E		UPDATE SPEC.	APR19/17	L.CHAN

LED SPECIFICATIONS:

FORWARD VOLTAGE: 2.1 VOLTS TYP.
REVERSE VOLTAGE: 5.0 VOLTS MIN.
LUMINOUS INTENSITY: 0.5 mCd MIN.

(AT If=2mA)

OPERATING TEMPERATURE: -55° TO 85° C

LEAD SOLDERING TEMPERATURE: 260° C
(5 SEC, 1/16" FROM CASE)

PLATING ON TAILS: TIN OR TIN/COPPER
ALLOY OVER SILVER

PRIMARY COLOR FOR BI-COLOR
LEDS IN STANDARD ANODE/
CATHODE CONFIGURATION IS:
RED-GREEN= RED
RED-YELLOW= RED
GREEN-YELLOW= GREEN
GREEN-ORANGE= GREEN

LEGEND

BiC=BI-COLOR LED
LOWC=LOW CURRENT LED
YE=YELLOW
GR=GREEN
RD=RED
OR=ORANGE

NOTE:

THE TWO DIGITS PRECEDING THE
ADDITIONAL LED CODE MUST BE
USED IN THE PART NUMBER, WHEN
ORDERING ANY OF THE ADDITIONAL
LED OPTIONS.

DRAWN K. LAMBIE	DATE SEP21/04
DESIGNED	
CHECKED	
I. E. APPRD.	
Q. A. APPRD.	
DWG. APPRD.	
ENG. REL. NO.	
REF.	
DIMENSIONS ARE IN INCHES [mm]	CODE ID. NO. 03554

Amphenol Canada Corp.

TITLE
LED OPTIONS FOR RJHSE, SINGLE
OR MULTI-PORT CONNECTORS
- RoHS COMPLIANT

DWG	DRAWING NO.	REV.
	P-RJHSE-LEDS	E
SCALE	WT. -----	SURF. -----
		SHEET 1 OF 1

THIS DOCUMENT CONTAINS PROPRIETARY INFORMATION AND SUCH INFORMATION
MAY NOT BE DISCLOSED TO OTHERS FOR ANY PURPOSE OR USED FOR MANUFACTURING
PURPOSES WITHOUT WRITTEN PERMISSION FROM AMPHENOL CANADA CORP.