

THIS DRAWING IS UNPUBLISHED. RELEASED FOR PUBLICATION
 © COPYRIGHT BY TYCO ELECTRONICS CORPORATION. ALL RIGHTS RESERVED.

LOC	DIST	REVISIONS			
P	LTR	DESCRIPTION	DATE	DWN	APVD
GP	00	C	REVISED PER ECO-08-019103	19AUG2008	ZMRCWR

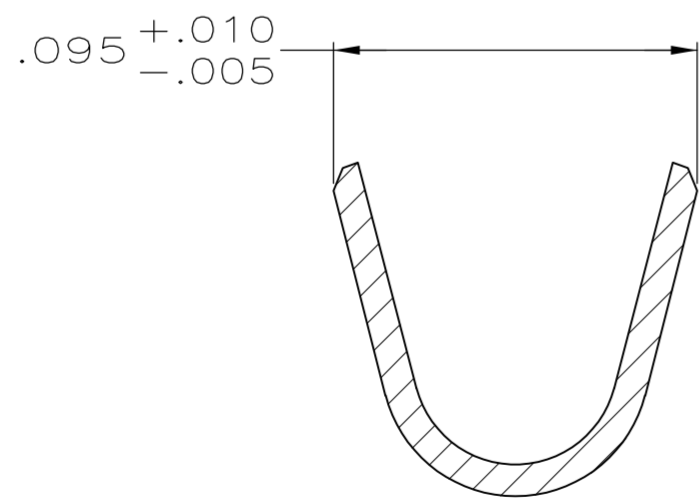

SECTION X-X
SCALE 20:1

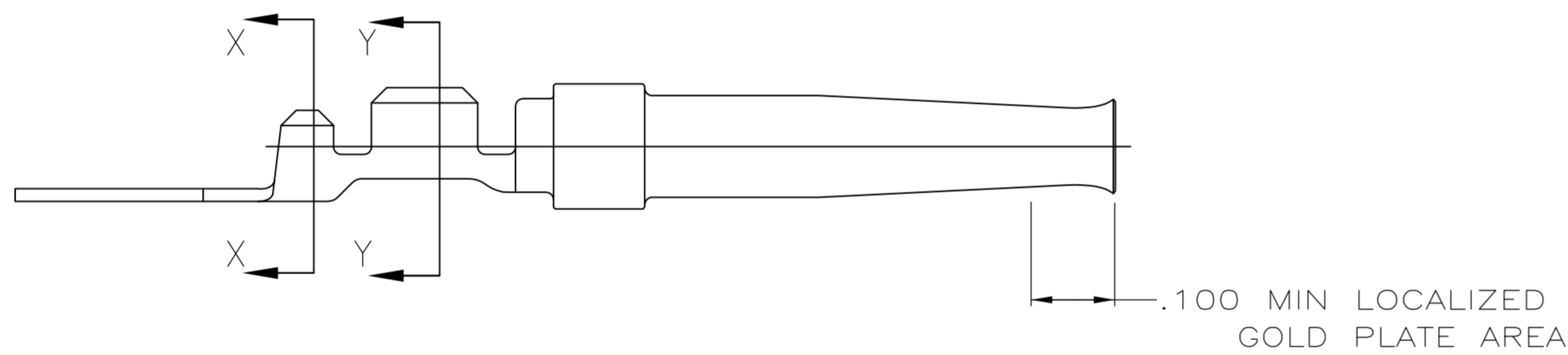
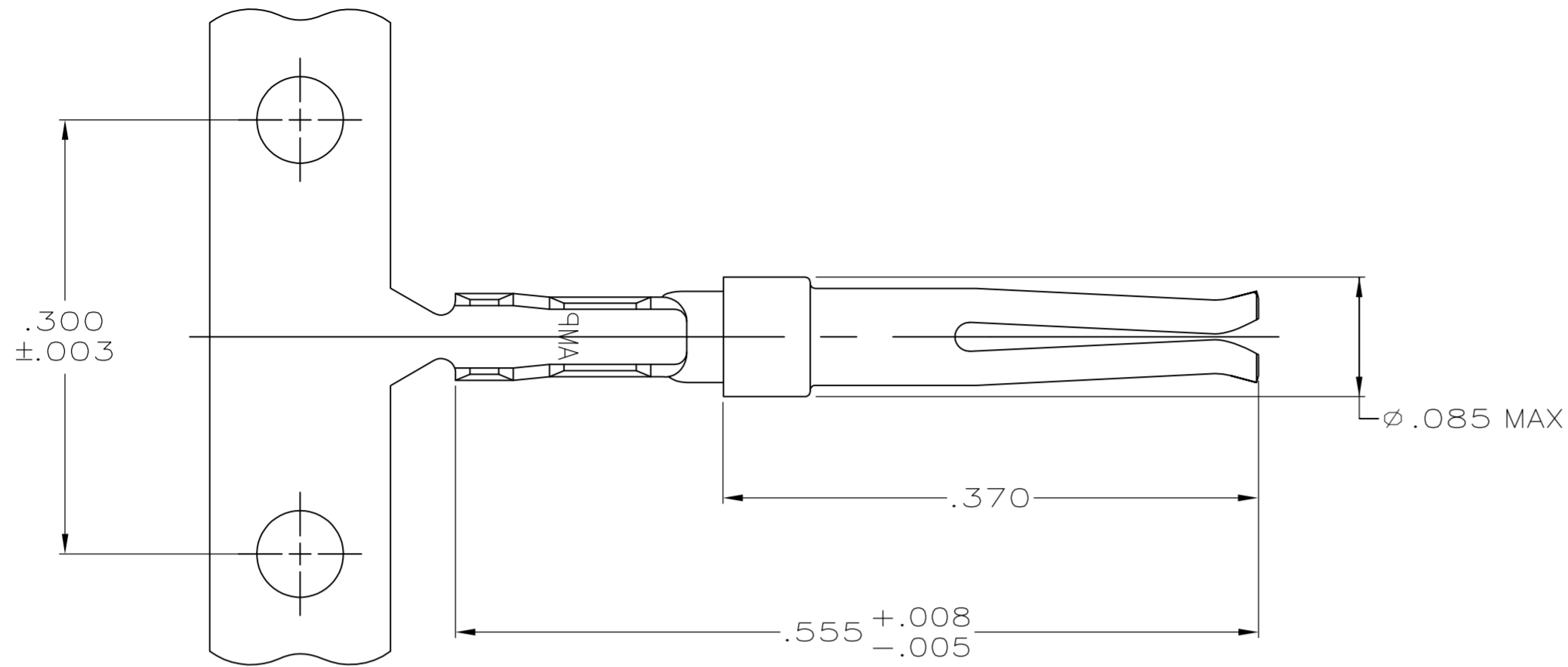
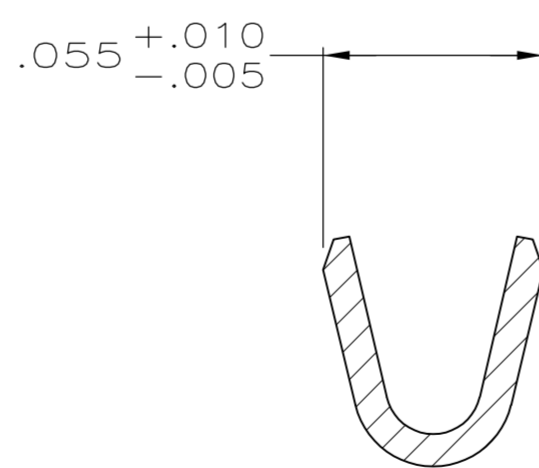

SECTION Y-Y
SCALE 20:1

- ① PLATED WITH .000030 GOLD ON INSIDE OF LOCALIZED GOLD PLATE AREA, .000100 TIN ON CRIMP BARRELS, ALL OVER .000050 NICKEL UNDERPLATE.
-OR-
GOLD FLASH OVER PALLADIUM-NICKEL .000030 TOTAL ON INSIDE OF LOCALIZED GOLD PLATE AREA, .000100 TIN ON CRIMP BARRELS, ALL OVER .000050 NICKEL UNDERPLATE.
- ② GOLD FLASH ON INSIDE OF LOCALIZED GOLD PLATE AREA, .000100 TIN PLATED CRIMP BARRELS, ALL OVER .000030 NICKEL UNDERPLATE.
- ③ CRIMP STRIP USING AMP MINI APPLICATOR.
- ④ CONTACT ACCEPTS WIRE RANGE OF 24-28 AWG AND INSULATION RANGE OF .050-.060.

①	1-5066683-0
②	5066683-7
FINISH	PART NUMBER

THIS DRAWING IS A CONTROLLED DOCUMENT.		DWN G. ATTADIA 11-10-04	Tyco Electronics Corporation Harrisburg, PA 17105-3608	
DIMENSIONS: INCHES		CHK J. GERACE 11-10-04	NAME SOCKET CONTACT, SIZE 20 DF, AMPLIMITE	
TOLERANCES UNLESS OTHERWISE SPECIFIED:		APVD M. WALMSLEY 11-10-04	DRAWING NO C=5066683	
0 PLC ± -		PRODUCT SPEC 108-40005	SIZE A2	CAGE CODE 00779
1 PLC ± -		APPLICATION SPEC 114-10000	SCALE 10:1	SHEET 1 of 1
2 PLC ± -		WEIGHT -	RESTRICTED TO	REV C
3 PLC ± .005		CUSTOMER DRAWING		
4 PLC ± -				
ANGLES ± -				
FINISH SEE TABLE				