

**NuMicro<sup>®</sup> Family**  
**Arm<sup>®</sup> Cortex<sup>®</sup>-M0-based Microcontroller**

**NuMaker-NUC029SGE**  
**User Manual**

***Evaluation Board for NuMicro<sup>®</sup> NUC029SG Series***

*The information described in this document is the exclusive intellectual property of Nuvoton Technology Corporation and shall not be reproduced without permission from Nuvoton.*

*Nuvoton is providing this document only for reference purposes of NuMicro microcontroller and microprocessor based system design. Nuvoton assumes no responsibility for errors or omissions.*

*All data and specifications are subject to change without notice.*

For additional information or questions, please contact: Nuvoton Technology Corporation.

[www.nuvoton.com](http://www.nuvoton.com)

**Table of Contents**

**1 OVERVIEW ..... 6**

**2 FEATURES ..... 7**

**3 HARDWARE CONFIGURATION ..... 8**

    3.1 Front View..... 8

    3.2 Rear View ..... 9

    3.3 Extension Connectors..... 10

        3.3.1 Pin Assignment for Extension Connectors .....10

        3.3.2 Arduino UNO Compatible Extension Connectors .....13

    3.4 Power Supply Configuration ..... 15

        3.4.1 VIN Power Source .....15

        3.4.2 5 V Power Sources .....15

        3.4.3 3.3 V Power Sources .....16

        3.4.4 1.8 V Power Sources .....16

        3.4.5 Power Connectors .....16

        3.4.6 USB Connectors .....17

        3.4.7 Power Switches .....17

        3.4.8 Power Supply Models .....17

    3.5 External Reference Voltage Connector..... 21

    3.6 Ammeter Connector ..... 21

    3.7 Push Buttons ..... 21

    3.8 LEDs..... 22

    3.9 Nu-Link2-Me..... 22

        3.9.1 VCOM Switches.....22

        3.9.2 Status LEDs .....23

**4 QUICK START ..... 24**

    4.1 Toolchains Supporting ..... 24

    4.2 Nuvoton Nu-Link Driver Installation ..... 24

    4.3 BSP Firmware Download ..... 26

    4.4 Hardware Setup..... 26

    4.5 Find the Example Project ..... 28

    4.6 Execute the Project under Toolchains ..... 28

        4.6.1 Keil MDK.....28

        4.6.2 IAR EWARM.....32

**5 NUMAKER-NUC029SGE SCHEMATICS ..... 34**

    5.1 Nu-Link2-Me..... 34

5.2 NuMaker-NUC029SGE Schematics..... 35

5.3 Extension Connectors..... 36

5.4 PCB Placement ..... 37

**6 REVISION HISTORY ..... 38**

**List of Figures**

Figure 1-1 NuMaker-NUC029SGE Evaluation Board ..... 6

Figure 3-1 Front View of NuMaker-NUC029SGE ..... 8

Figure 3-2 Rear View of NuMaker-NUC029SGE ..... 9

Figure 3-3 NUC029SGE Extension Connectors ..... 10

Figure 3-4 Arduino UNO Compatible Extension Connectors ..... 13

Figure 3-5 External Power Supply Sources on Nu-Link2-Me ..... 17

Figure 3-6 External Power Supply Sources on NUC029SG Target Board ..... 18

Figure 3-7 Detach the Nu-Link2-Me from NuMaker-NUC029SGE ..... 19

Figure 3-8 Wiring between Ammeter Connector and Ammeter ..... 21

Figure 4-1 Nu-Link USB Driver Installation Setup ..... 24

Figure 4-2 Nu-Link USB Driver Installation ..... 25

Figure 4-3 Open VCOM Function ..... 26

Figure 4-4 ICE USB Connector ..... 26

Figure 4-5 Device Manger ..... 27

Figure 4-6 PuTTY Session Setting ..... 27

Figure 4-7 Template Project Folder Path ..... 28

Figure 4-8 Warning Message of “Device not found” ..... 28

Figure 4-9 Project File Migrate to Version 5 Format ..... 29

Figure 4-10 Debugger Setting in Options Window ..... 29

Figure 4-11 Programming Setting in Options Window ..... 30

Figure 4-12 Compile and Download the Project ..... 30

Figure 4-13 Keil MDK Debug Mode ..... 31

Figure 4-14 Debug Message on Serial Port Terminal Windows ..... 31

Figure 4-15 IAR EWARM Window ..... 32

Figure 4-16 Compile and Download the Project ..... 32

Figure 4-17 IAR EWARM Debug Mode ..... 33

Figure 4-18 Debug Message on Serial Port Terminal Windows ..... 33

Figure 5-1 Nu-Link2-Me Circuit ..... 34

Figure 5-2 NUC029SGE Target Board Circuit ..... 35

Figure 5-3 Extension Connectors Circuit ..... 36

Figure 5-4 Front Placement ..... 37

Figure 5-5 Rear Placement ..... 37

**List of Tables**

Table 3-1 Extension Connectors..... 10

Table 3-2 NUC029SG Full-pin Extension Connectors and GPIO Function List ..... 12

Table 3-3 Arduino UNO Extension Connectors and NUC029SG Mapping GPIO List ..... 14

Table 3-4 Vin Power Source ..... 15

Table 3-5 5 V Power Sources ..... 15

Table 3-6 3.3 V Power Sources ..... 16

Table 3-7 1.8 V Power Sources ..... 16

Table 3-8 Power Connectors ..... 16

Table 3-9 USB Connectors ..... 17

Table 3-10 Power Switches ..... 17

Table 3-11 Supply External Power through Nu-Link2-Me ..... 18

Table 3-12 Supply External Power for NUC029SG Target Board ..... 20

Table 3-13 External Reference Voltage Connector ..... 21

Table 3-14 Ammeter Connector ..... 21

Table 3-15 Push Buttons..... 21

Table 3-16 LEDs ..... 22

Table 3-17 VCOM Function of Nu-Link2-Me..... 22

Table 3-18 Operation Status LED Patterns ..... 23

## 1 OVERVIEW

The NuMaker-NUC029SGE is an evaluation board for Nuvoton NuMicro NUC029SGE and NUC029LGE microcontrollers. The NuMaker-NUC029SGE consists of two parts: an NUC029SG target board and an on-board Nu-Link2-Me debugger and programmer. The NuMaker-NUC029SGE is designed for project evaluation, prototype development and validation with power consumption monitoring function.

The NUC029SG target board is based on NuMicro NUC029SGE. For the development flexibility, the NUC029SG target board provides the extension connectors, the Arduino UNO compatible headers and the capability of adopting multiple power supplies. Furthermore, the Nuvoton-designed ammeter connector can measure the power consumption instantly, which is essential for the prototype evaluation.

In addition, there is an attached on-board debugger and programmer “Nu-Link2-Me”. The Nu-Link2-Me supports on-chip debugging, online and offline ICP programming via SWD interface. The Nu-Link2-Me supports virtual COM (VCOM) port for printing debug messages on PC. Besides, the programming status could be shown on the built-in LEDs. Lastly, the Nu-Link2-Me could be detached from the evaluation board and become a stand-alone mass production programmer.

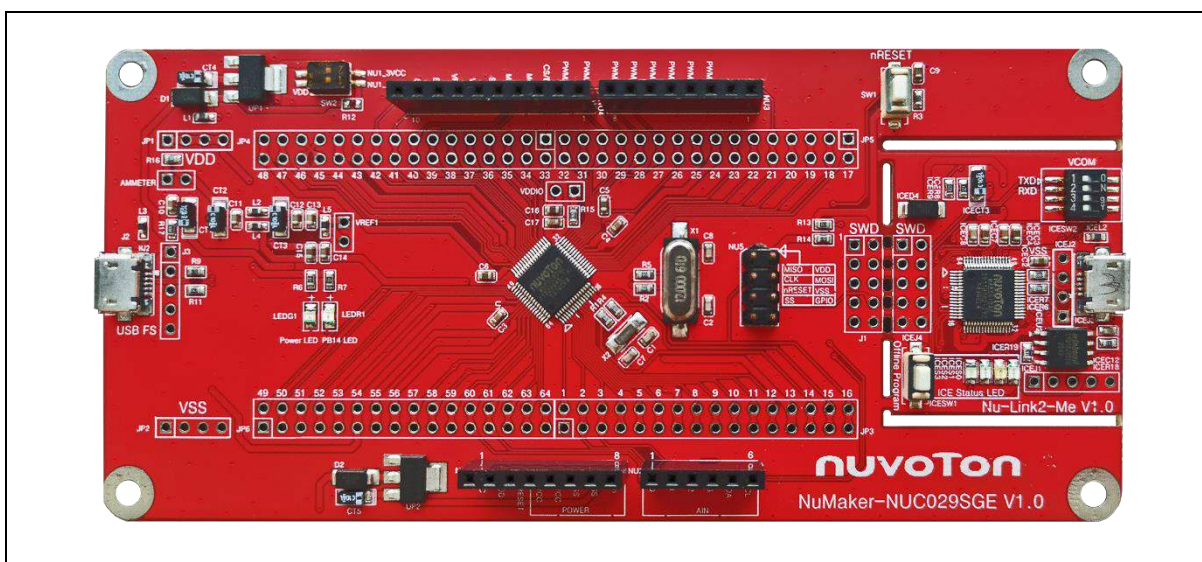

Figure 1-1 NuMaker-NUC029SGE Evaluation Board

## 2 FEATURES

- NuMicro NUC029SGE used as main microcontroller with function compatible with:
  - NUC029SGE
  - NUC029LGE
- NUC029SGE full pins extension connectors
- Arduino UNO compatible extension connectors
- Ammeter connector for measuring the microcontroller's power consumption
- Flexible board power supply:
  - External  $V_{DD}$  power connector
  - Arduino UNO compatible extension connector  $V_{in}$
  - USB FS connector on NUC029SG target board
  - ICE USB connector on Nu-Link2-Me
- On-board Nu-Link2-Me debugger and programmer:
  - Debug through SWD interface
  - Online/offline programming
  - Virtual COM port function

### 3 HARDWARE CONFIGURATION

#### 3.1 Front View

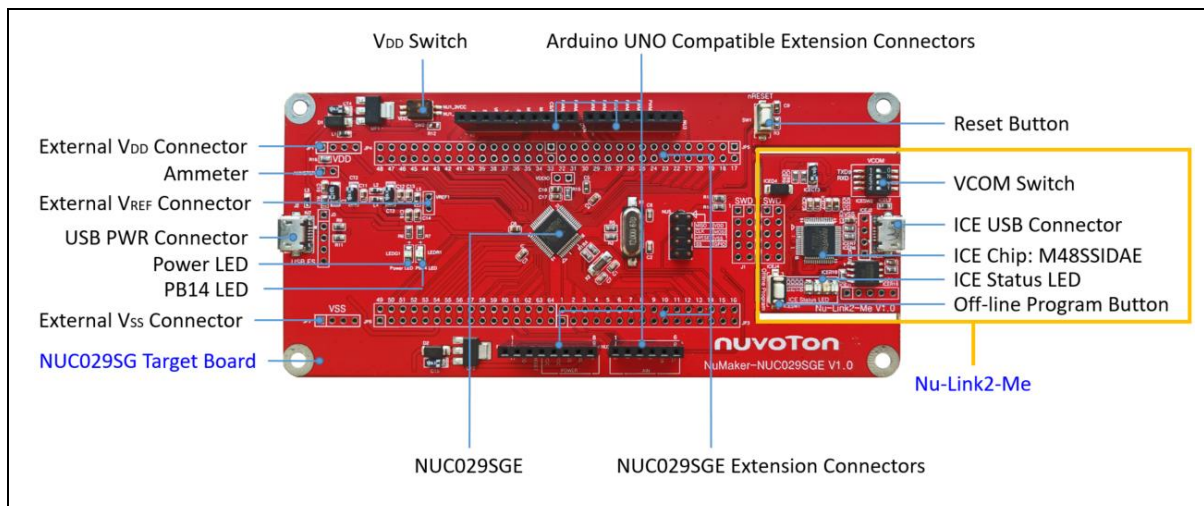

Figure 3-1 Front View of NuMaker-NUC029SGE

Figure 3-1 shows the main components and connectors from the front side of NuMaker-NUC029SGE. The following lists components and connectors from the front view:

- Target chip: NUC029SGE (U1)
- USB PWR Connector (J2)
- Arduino UNO Compatible Extension Connectors (NU1, NU2, NU3, NU4)
- NUC029SG Extension Connectors (JP3, JP4, JP5 and JP6)
- External V<sub>DD</sub> Power Connector (JP1)
- External V<sub>SS</sub> Power Connector (JP2)
- External V<sub>REF</sub> Connector (VREF1)
- V<sub>DD</sub> Switch (SW2)
- Ammeter Connector (AMMETER)
- Reset Button (SW1)
- Power LED and PB14 LED (LEDG1 and LEDR1)
- Nu-Link2-Me
  - VCOM Switch
  - ICE Chip: M48SSIDAE (ICEU2)
  - ICE USB Connector (ICEJ3)
  - ICE Status LED (ICES0, ICES1, ICES2, ICES3)
  - Off-line Program Button (ICESW1)



### 3.2 Rear View

Figure 3-2 shows the main components and connectors from the rear side of NuMaker-NUC029SGE.

The following lists components and connectors from the rear view:

- Nu-Link2-Me
  - MCUVCC Power Switch (ICEJPR1)
  - ICEVCC Power Switch (ICEJPR2)

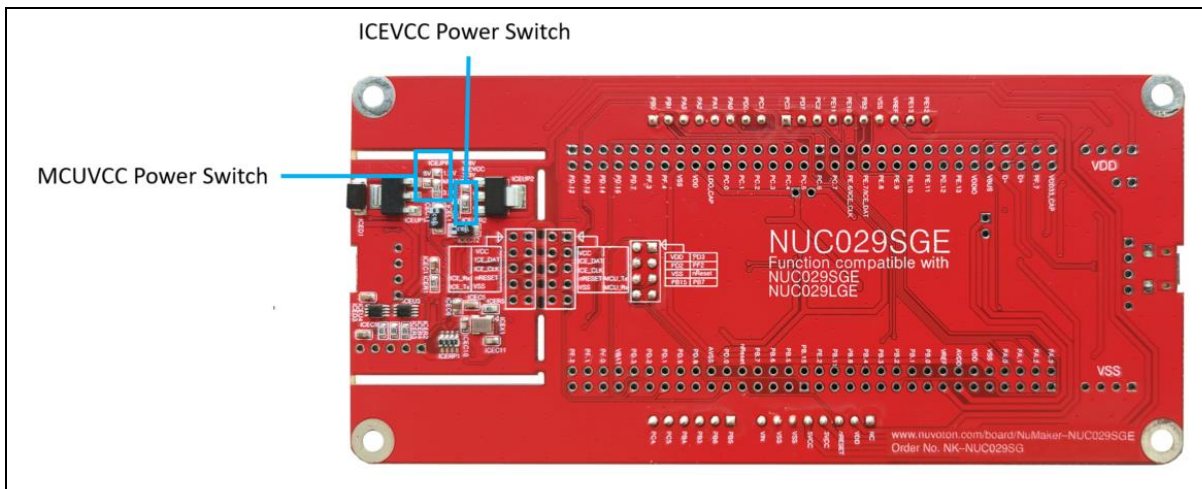

Figure 3-2 Rear View of NuMaker-NUC029SGE

### 3.3 Extension Connectors

Table 3-1 presents the extension connectors.

Connector	Description
JP3, JP4, JP5 and JP6	Full pins extension connectors on the NuMaker-NUC029SGE.
NU1, NU2, NU3 and NU4	Arduino UNO compatible pins on the NuMaker-NUC029SGE.

Table 3-1 Extension Connectors

#### 3.3.1 Pin Assignment for Extension Connectors

The NuMaker-NUC029SGE provides the NUC029SGE onboard and extension connectors (JP3, JP4, JP5 and JP6). Figure 3-3 shows the NUC029SGE extension connectors.

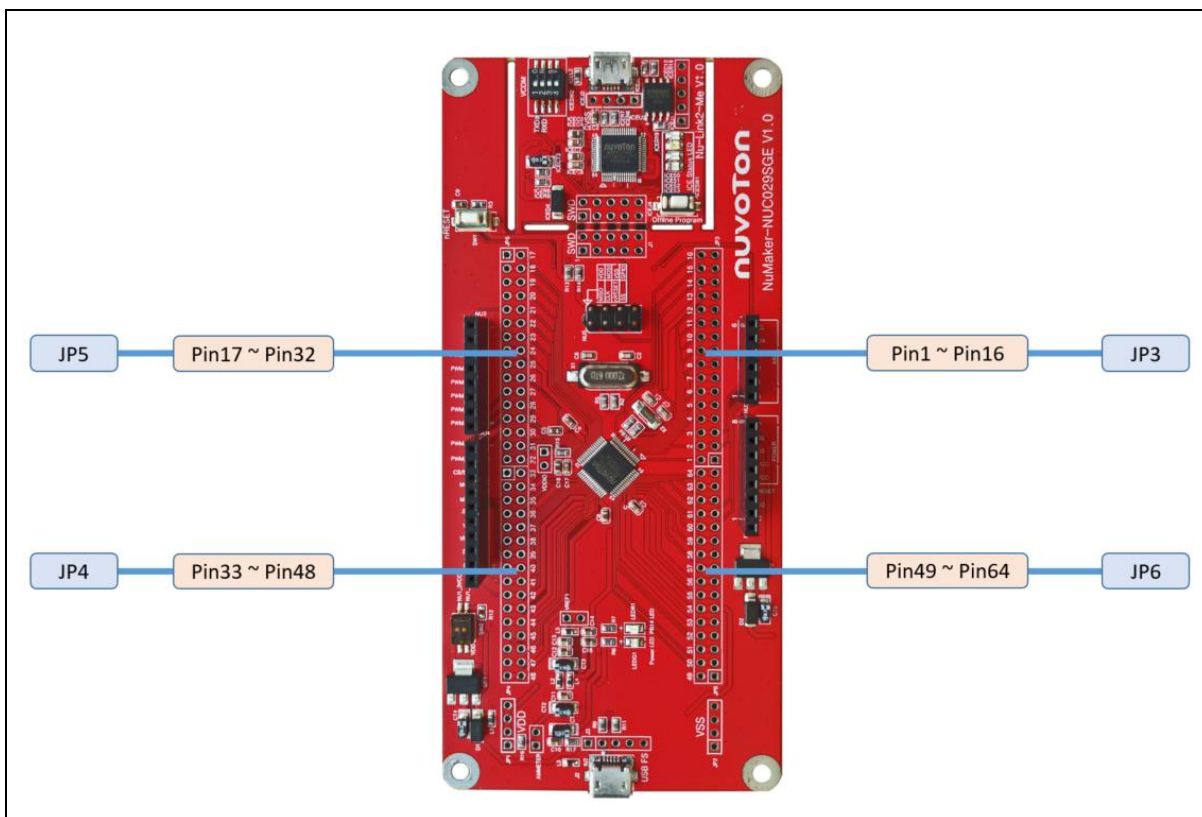

Figure 3-3 NUC029SGE Extension Connectors

Header		NUC029SGE	
		Pin No.	Function
JP3	JP3.1	1	PB.15/ADC0_CH12/ACMP0_P3/EBI_nCS1
	JP3.2	2	PB.5/ADC0_CH13/SPI0_MOSI/SPI1_MOSI/ACMP0_P2/SC1_RST/EBI_AD6/UART2_RXD
	JP3.3	3	PB.6/ADC0_CH14/SPI0_MISO/SPI1_MISO/ACMP0_P1/SC1_PWR/EBI_AD5
	JP3.4	4	PB.7/ADC0_CH15/SPI0_CLK/SPI1_CLK/USCI2_CTL1/ACMP0_P0/SC1_DAT/EBI_AD4
	JP3.5	5	nRESET · Note: It is recommended to use 10 kΩ pull-up resistor and 10 uF capacitor on nRESET pin.
	JP3.6	6	PD.0/SPI0_I2SMCLK/SPI1_I2SMCLK/UART0_RXD/USCI2_CTL0/ACMP1_N/SC1_CLK/INT3
	JP3.7	7	AVSS
	JP3.8	8	PD.8/ADC0_CH17/UART0_nCTS/USCI2_CTL1/TM2/EBI_nCS0
	JP3.9	9	PD.9/ADC0_CH18/UART0_RXD/USCI2_CTL0/ACMP1_P3/TM3/EBI_ALE
	JP3.10	10	PD.1/ADC0_CH19/PWM0_SYNC_IN/UART0_TXD/USCI2_CLK/ACMP1_P2
	JP3.11	11	PD.2/ADC0_ST/TM0_EXT/USCI2_DAT0/ACMP1_P1/PWM0_BRAKE0/EBI_nWR/INT0
	JP3.12	12	PD.3/TM2/SPI0_I2SMCLK/TM1_EXT/USCI2_DAT1/ACMP1_P0/PWM0_BRAKE1/EBI_MCLK/INT1
	JP3.13	13	VBAT
	JP3.14	14	PF.0/X32_OUT/USCI2_CTL1/INT5
	JP3.15	15	PF.1/X32_IN/USCI2_CTL0/PWM1_BRAKE0
	JP3.16	16	PF.2/USCI2_CLK/PWM1_BRAKE1
JP5	JP5.1	17	PD.12/USCI1_CTL0/SPI1_SS/UART0_TXD/PWM1_CH0/EBI_ADR16
	JP5.2	18	PD.13/USCI1_DAT1/SPI1_MOSI/UART0_RXD/PWM1_CH1/EBI_ADR17
	JP5.3	19	PD.14/USCI1_DAT0/SPI1_MISO/UART0_nCTS/PWM1_CH2/EBI_ADR18
	JP5.4	20	PD.15/USCI1_CLK/SPI1_CLK/UART0_nRTS/PWM1_CH3/EBI_ADR19
	JP5.5	21	PD.7/USCI1_CTL1/SPI0_I2SMCLK/PWM0_SYNC_IN/TM1/ACMP0_O/PWM0_CH5/EBI_nRD
	JP5.6	22	PF.3/XT1_OUT/I2C1_SCL
	JP5.7	23	PF.4/XT1_IN/I2C1_SDA
	JP5.8	24	VSS
	JP5.9	25	VDD
	JP5.10	26	LDO_CAP
	JP5.11	27	PC.0/SC0_DAT/SPI0_CLK/UART2_nCTS/USCI0_DAT0/ACMP0_WLAT/PWM0_CH0/EBI_AD8/INT2
	JP5.12	28	PC.1/CLKO/SC0_CLK/UART2_nRTS/USCI0_DAT1/ACMP1_WLAT/PWM0_CH1/EBI_AD9
	JP5.13	29	PC.2/SC0_RST/SPI0_SS/UART2_TXD/USCI0_CTL1/ACMP1_O/PWM0_CH2/EBI_AD10
	JP5.14	30	PC.3/SC0_PWR/SPI0_MOSI/UART2_RXD/USCI0_CTL0/PWM0_CH3/EBI_AD11
	JP5.15	31	PC.4/SC0_nCD/SPI0_MISO/I2C1_SCL/USCI0_CLK/PWM0_CH4/EBI_AD12
	JP5.16	32	PC.5/SPI0_I2SMCLK/I2C1_SDA/USCI0_DAT0/PWM0_CH5/EBI_AD13

Header		NUC029SGE	
		Pin No.	Function
JP4	JP4.1	33	PC.6/USCI0_DAT1/ACMP1_O/PWM1_CH0/EBI_AD14
	JP4.2	34	PC.7/USCI0_CTL1/PWM1_CH1/EBI_AD15
	JP4.3	35	PE.6/ICE_CLK/I2C0_SCL/UART0_RXD
	JP4.4	36	PE.7/ICE_DAT/I2C0_SDA/UART0_TXD
	JP4.5	37	PE.8/UART1_TXD/TM0/I2C1_SCL/SC0_PWR
	JP4.6	38	PE.9/UART1_RXD/TM1/I2C1_SDA/SC0_RST
	JP4.7	39	PE.10/SPI1_MISO/SPI0_MISO/UART1_nCTS/SC0_DAT/SPI1_CLK/EBI_AD7/TM0_EXT
	JP4.8	40	PE.11/SPI1_MOSI/SPI0_MOSI/UART1_nRTS/SC0_CLK/SPI1_MISO/EBI_AD6/TM1_EXT
	JP4.9	41	PE.12/SPI1_SS/SPI0_SS/UART1_TXD/I2C0_SCL/SPI1_MOSI/EBI_AD5/TM2_EXT
	JP4.10	42	PE.13/SPI1_CLK/SPI0_CLK/UART1_RXD/I2C0_SDA/SPI1_SS/EBI_AD4/TM3_EXT
	JP4.11	43	VDDIO
	JP4.12	44	USB_VBUS
	JP4.13	45	USB_D-
	JP4.14	46	USB_D+
	JP4.15	47	PF.7
	JP4.16	48	USB_VDD33_CAP
JP6	JP6.1	49	PA.3/UART0_RXD/UART0_nRTS/I2C0_SCL/SC0_PWR/PWM1_CH2/EBI_AD3/USCI1_CLK
	JP6.2	50	PA.2/UART0_TXD/UART0_nCTS/I2C0_SDA/SC0_RST/PWM1_CH3/EBI_AD2/USCI1_CTL0
	JP6.3	51	PA.1/UART1_nRTS/UART1_RXD/USCI1_CTL1/SC0_DAT/PWM1_CH4/EBI_AD1
	JP6.4	52	PA.0/UART1_nCTS/UART1_TXD/USCI1_CTL0/SC0_CLK/PWM1_CH5/EBI_AD0/INT0
	JP6.5	53	VSS
	JP6.6	54	VDD
	JP6.7	55	AVDD
	JP6.8	56	VREF
	JP6.9	57	PB.0/ADC0_CH0/VDET_P0/UART2_RXD/TM2/USCI1_DAT0/EBI_nWRL/INT1/TM1_EXT
	JP6.10	58	PB.1/ADC0_CH1/VDET_P1/UART2_TXD/TM3/SC0_RST/PWM0_SYNC_OUT/EBI_nWRH/USCI1_DAT1
	JP6.11	59	PB.2/ADC0_CH2/SPI0_CLK/SPI1_CLK/UART1_RXD/SC0_nCD/TM_BRAKE0/EBI_nCS0/USCI0_DAT0/TM2_EXT
	JP6.12	60	PB.3/ADC0_CH3/SPI0_MISO/SPI1_MISO/UART1_TXD/TM_BRAKE1/EBI_ALE/USCI0_DAT1/TM0_EXT
	JP6.13	61	PB.4/ADC0_CH4/SPI0_SS/SPI1_SS/UART1_nCTS/ACMP0_N/SC1_nCD/EBI_AD7/USCI0_CTL1/UART2_RXD/TM1_EXT
	JP6.14	62	PB.8/ADC0_CH5/UART1_nRTS/TM_BRAKE2/PWM0_CH2/USCI0_CTL0
	JP6.15	63	PB.11/ADC0_CH8
	JP6.16	64	PE.2/ADC0_CH9/UART1_nRTS/TM_BRAKE3/PWM0_CH2/USCI0_CTL0

Table 3-2 NUC029SG Full-pin Extension Connectors and GPIO Function List

### 3.3.2 Arduino UNO Compatible Extension Connectors

Figure 3-4 shows the Arduino UNO compatible extension connectors.

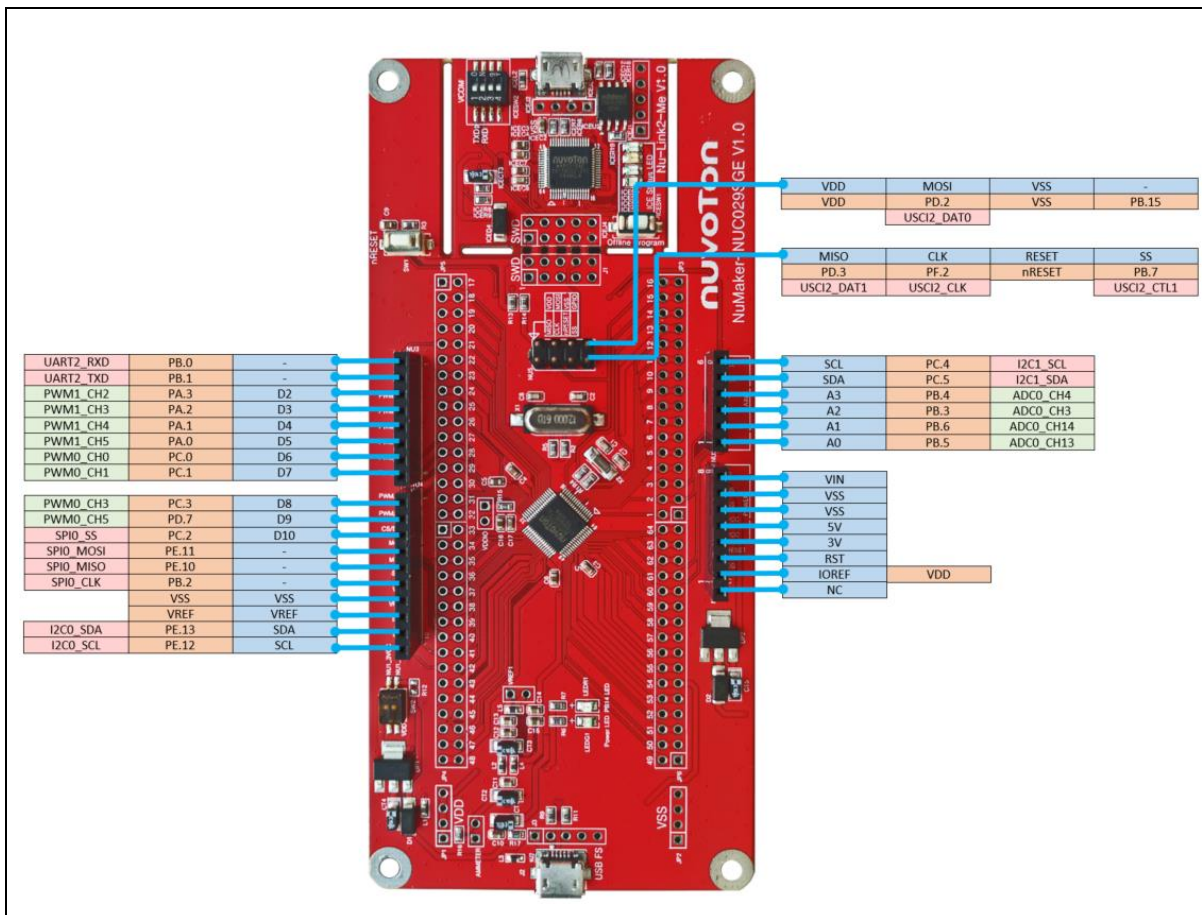

Figure 3-4 Arduino UNO Compatible Extension Connectors

Header		NuMaker-NUC029SGE		Header		NuMaker-NUC029SGE	
		Compatible to Arduino UNO	GPIO Pin of NUC029SG			Compatible to Arduino UNO	GPIO Pin of NUC029SG
NU3	NU3.1	RX	PB.0	NU2	NU2.6	SCL	PC.4
	NU3.2	TX	PB.1		NU2.5	SDA	PC.5
	NU3.3	D2	PA.3		NU2.4	A3	PB.4
	NU3.4	D3	PA.2		NU2.3	A2	PB.3
	NU3.5	D4	PA.1		NU2.2	A1	PB.6
	NU3.6	D5	PA.0		NU2.1	A0	PB.5
	NU3.7	D6	PC.0	NU1	NU1.8	VIN	-
	NU3.8	D7	PC.1		NU1.7	VSS	
NU4	NU4.1	D8	PC.3		NU1.6	VSS	
	NU4.2	D9	PD.7		NU1.5	5V	
	NU4.3	SS/D10	PC.2		NU1.4	3V	
	NU4.4	MOSI	PE.11		NU1.3	RST	nRESET
	NU4.5	MISO	PE.10		NU1.2	IOREF	V <sub>REF</sub>
	NU4.6	SCK	PB.2		NU1.1	NC	-
	NU4.7	VSS	V <sub>SS</sub>				
	NU4.8	VREF	V <sub>REF</sub>				
	NU4.9	SDA	PE.13				
	NU4.10	SCL	PE.12				

Table 3-3 Arduino UNO Extension Connectors and NUC029SG Mapping GPIO List

### 3.4 Power Supply Configuration

The NuMaker-NUC029SGE is able to adopt multiple power supplies. External power sources include NU1 Vin (7 V to 12 V), V<sub>DD</sub> (depending on the target chip operating voltage), and PC through USB connector. By using switches and voltage regulator, multiple power domains can be created on the NuMaker-NUC029SGE.

#### 3.4.1 VIN Power Source

Table 3-4 presents the Vin power source.

Connector	Net Name in Schematic	Description
NU1 pin8	NU1_VIN	Board external power source, with voltage range from 7 V to 12 V. The voltage regulator UP2 converts the NU1 pin8 input voltage to 5 V and supplies it to NU1_5VCC.

Table 3-4 Vin Power Source

#### 3.4.2 5 V Power Sources

Table 3-5 presents the 5 V power sources.

Connector	Net Name in Schematic	Description
ICEJ3	USB_HS_VBUS	ICE USB connector supplies 5 V power from PC to NUC029SG target board and Nu-Link2-Me.
J2	USB_VBUS	USB connector on NuMaker-NUC029SGE supplies 5 V power from PC to NUC029SG target board and Nu-Link2-Me.
NU1 pin5	NU1_5VCC	ICEJ3, J2 or NU1 pin8 supplies 5 V power to NU1 pin5. NU1 pin5 supplies 5 V power to target chip or Arduino adapter board.

Table 3-5 5 V Power Sources

### 3.4.3 3.3 V Power Sources

Table 3-6 presents the 3.3 V power sources.

Voltage Regulator	5 V Source	Description
ICEUP1	USB_HS_VBUS	ICEUP1 converts USB_HS_VBUS to 3.3 V and supplies 3.3 V to NUC029SG target board or ICE chip.
UP1	USB_VBUS	UP1 converts USB_VBUS to 3.3 V and supplies 3.3 V to NUC029SG target board. <b>Note:</b> SW2.2 (NU1 3VCC) should be switched to ON.
UP1	NU1_5VCC	UP1 converts NU1_5VCC to 3.3 V and supplies 3.3 V to NUC029SG target board. <b>Note:</b> SW2.2 (NU1 3VCC) should be switched to ON.

Table 3-6 3.3 V Power Sources

### 3.4.4 1.8 V Power Sources

Table 3-7 presents the 1.8 V power source.

Voltage Regular	5V Source	Description
ICEUP2	USB_HS_VBUS	ICEUP2 converts USB_HS_VBUS to 1.8 V and supplies 1.8 V to NUC029SG target board or ICE chip.

Table 3-7 1.8 V Power Sources

### 3.4.5 Power Connectors

Table 3-8 presents the power connectors.

Connector	Description
JP1	V <sub>DD</sub> connector on the NuMaker-NUC029SGE.
JP2	V <sub>SS</sub> connector on the NuMaker-NUC029SGE.

Table 3-8 Power Connectors



### 3.4.6 USB Connectors

Table 3-9 presents the USB connectors.

Connector	Description
ICEJ3	ICE USB connector on Nu-Link2-Me for power supply, debugging and programming from PC.
J2	USB FS connector on NuMaker-NUC029SGE for power supply.

Table 3-9 USB Connectors

### 3.4.7 Power Switches

Table 3-10 presents the power switches.

Switch	Description
ICEJPR1	Configures the target chip operating voltage at 1.8 V / 3.3 V / 5 V.
ICEJPR2	Configures the ICE chip operating voltage at 1.8 V / 3.3 V.
SW2	Configures the target chip operating voltage at 3.3 V / 5 V.

Table 3-10 Power Switches

### 3.4.8 Power Supply Models

#### 3.4.8.1 External Power Supply through Nu-Link2-Me to Target Chip

The external power supply source on Nu-Link2-Me is shown in Figure 3-5.

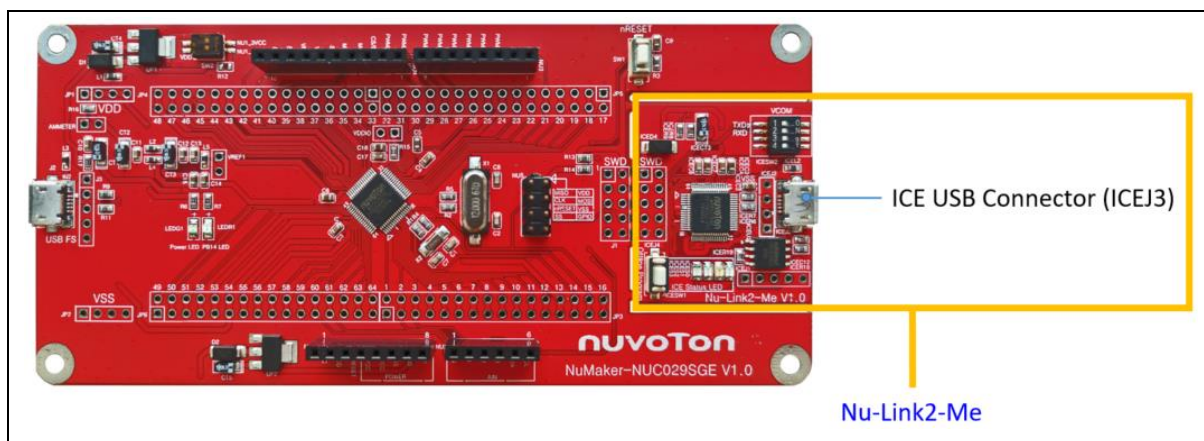

Figure 3-5 External Power Supply Sources on Nu-Link2-Me

To use ICEJ3 as external power supply source with Nu-Link2-Me, please follow the steps below:

1. Solder the resistor on ICEJPR1 (MCUVCC) depending on the target chip operating voltage.
2. Solder the resistor on ICEJPR2 (ICEVCC) depending on the ICE chip operating voltage.
3. Switch the SW2 to OFF.

4. Connect the external power supply to ICEJ3.

Table 3-11 presents all power models when supplying external power through Nu-Link2-Me. The Nu-Link2-Me external power sources are highlighted in yellow.

Model	Target Chip Voltage	ICEJ3	ICEJPR1 (MCUVCC) Selection <sup>[1]</sup>	ICEJPR2 (ICEVCC) Selection <sup>[2]</sup>	ICE Chip Voltage	SW2 Selection	J2	Vin	JP1
1	1.8 V	Connect to PC	1.8 V	1.8 V	1.8 V	Off	-	-	1.8 V output
2	3.3 V	Connect to PC	3.3 V (default)	3.3 V (default)	3.3 V	Off	-	-	3.3 V output
3	5 V	Connect to PC	5 V	3.3 V (default)	3.3 V	Off	-	-	5 V output
<p><b>Note:</b></p> <p>1. 0 Ω should be soldered between ICEJPR1's MCVCC and 1.8 V / 3.3 V / 5 V.</p> <p>2. 0 Ω should be soldered between ICEJPR2's ICEVCC and 1.8 V / 3.3 V.</p> <p>3. -: Unused.</p>									

Table 3-11 Supply External Power through Nu-Link2-Me

### 3.4.8.2 External Power Supply through NUC029SG Target Board to Target Chip

The external power supply sources on NUC029SG target board are shown in Figure 3-6.

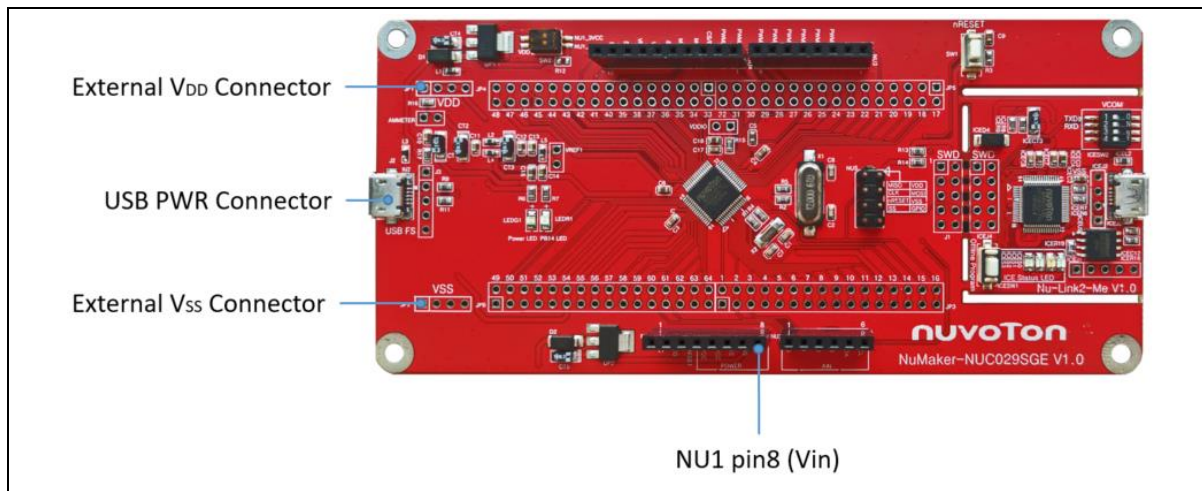

Figure 3-6 External Power Supply Sources on NUC029SG Target Board

To use Vin or J2 as external power supply source, please follow the steps below:

1. Switch the SW2 depending on the target chip operating voltage.
2. Remove the resistor on ICEJPR1 (MCUVCC).
3. Solder the resistor on ICEJPR2 (ICEVCC) depending on the ICE chip operating voltage.
4. Connect the external power supply to Vin or J2.

To use JP1 as external power supply source, please follow the steps below:

1. Switch the SW2 to OFF.
2. Remove the resistor on ICEJPR1 (MCUVCC).
3. Solder the resistor on ICEJPR2 (ICEVCC) depending on the ICE chip operating voltage.

4. Connect ICEJ3 to PC.
5. Connect the external power supply to JP1.

To use Vin or J2 as external power supply source with Nu-Link2-Me detached from NuMaker-NUC029SGE, please follow the steps below:

1. Switch the SW2 depending on the target chip operating voltage.
2. Detach the Nu-Link2-Me from NuMaker-NUC029SGE.
3. Connect the external power supply to Vin or J2.

To use JP1 as external power supply source with Nu-Link2-Me detached from NuMaker-NUC029SGE, please follow the steps below:

1. Switch the SW2 to OFF.
2. Detach the Nu-Link2-Me from NuMaker-NUC029SGE.
3. Connect the external power supply to JP1.

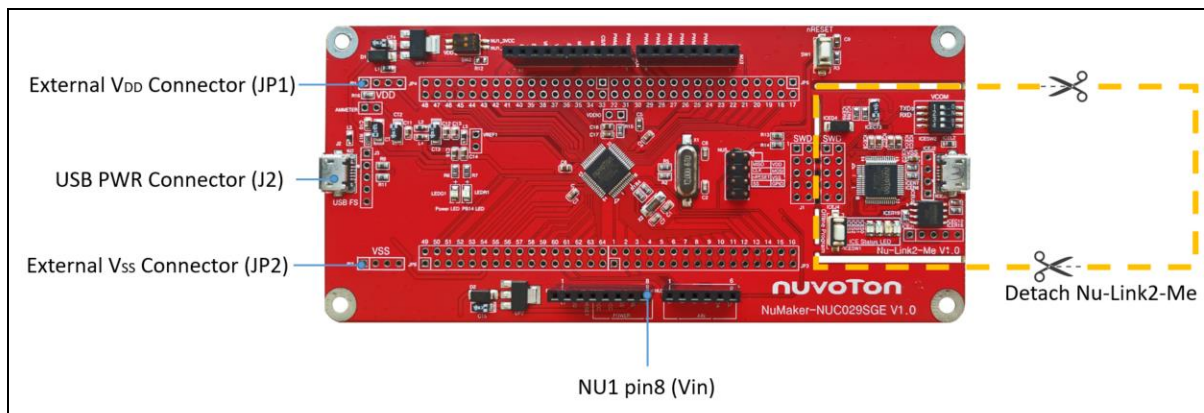

Figure 3-7 Detach the Nu-Link2-Me from NuMaker-NUC029SGE

Table 3-12 presents all power models when supplies external power through NUC029SG target board. The NUC029SG target board external power sources are highlighted in yellow.

Model	Target Chip Voltage	Vin <sup>[1]</sup>	J2 <sup>[1]</sup>	ICEJ3	SW2 Selection	JP1 <sup>[2]</sup>	ICEJPR1 (MCUVCC) Selection <sup>[3]</sup>	ICEJPR2 (ICEVCC) Selection <sup>[4]</sup>	ICE Chip Voltage <sup>[5]</sup>
4	3.3 V	7 V ~ 12 V Input	-	-	NU1 3VCC	3.3 V output	Remove resistor	3.3 V	3.3 V
5	3.3 V	-	Connect to PC	-	NU1 3VCC	3.3 V output	Remove resistor	3.3 V	3.3 V
6	5 V	7 V ~ 12 V Input	-	-	NU1 5VCC	5 V output	Remove resistor	3.3 V	3.3 V
7	5 V	-	Connect to PC	-	NU1 5VCC	5 V output	Remove resistor	3.3 V	3.3 V
8	2.5 V ~ 5.5 V	-	-	Connect to PC	OFF	DC Input 2.5 V ~ 5.5 V	Remove resistor	1.8 V / 3.3 V	1.8 V / 3.3 V
9	2.5 V ~ 5.5 V	-	-	Nu-Link2-Me removed	OFF	DC Input 2.5 V ~ 5.5 V	-	-	-

**Note:**

1. The Vin input voltage will be converted by voltage regulator UP2 to 5 V. Supplying external power to Vin or J2 can provide 5 V to NU1 pin5 (5V) and 3.3 V to NU1 pin4 (3VCC).
2. JP1 external power input only provides voltage to target chip.
3. 0 Ω should be removed from ICEJPR1's MCVCC and 1.8 V / 3.3 V / 5 V.
4. 0 Ω should be soldered between ICEJPR2's ICEVCC and 1.8 V / 3.3 V.
5. The ICE chip voltage should be close to the target chip voltage.
6. -: Unused

Table 3-12 Supply External Power for NUC029SG Target Board

### 3.5 External Reference Voltage Connector

Table 3-13 External Reference Voltage Connector presents the external reference voltage connector.

Connector	Description
VREF1	Connector for user to connect to the external reference voltage pin of the target chip. User needs to remove the L5 ferrite bead.

Table 3-13 External Reference Voltage Connector

### 3.6 Ammeter Connector

Table 3-14 presents the ammeter connector.

Connector	Description
AMMETER	Connector for user to measure the target chip power consumption easily. User needs to remove the R16 resistor.

Table 3-14 Ammeter Connector

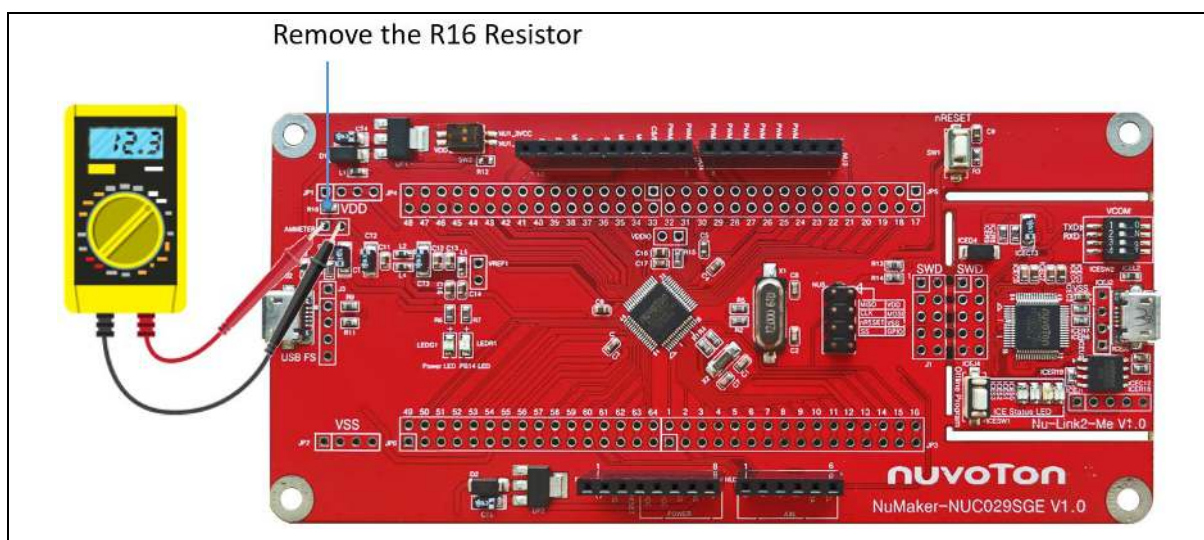

Figure 3-8 Wiring between Ammeter Connector and Ammeter

### 3.7 Push Buttons

Table 3-15 presents the push buttons.

Component	Description
ICESW1	Offline program button to start offline ICP programming the target chip.
SW1	Reset button to reset the target chip.

Table 3-15 Push Buttons

### 3.8 LEDs

Table 3-16 presents the LEDs.

Component	Description
Power LED	The power LED indicates that the NuMaker-NUC029SGE is powered.
PB14 LED	The LED is connected to the target chip PF.7.
ICES0, ICES1, ICES2 and ICES3	Nu-Link2-Me status LED.

Table 3-16 LEDs

### 3.9 Nu-Link2-Me

The Nu-Link2-Me is an attached on-board debugger and programmer. The Nu-Link2-Me supports on-chip debugging, online and offline ICP programming through SWD interface. The Nu-Link2-Me also supports virtual COM port (VCOM) for printing debug messages on PC. Besides, the programming status could be shown on the built-in LEDs. Lastly, the Nu-Link2-Me could be detached from the evaluation board and become a stand-alone mass production programmer. For more information about Nu-Link2-Me, please refer to *Nu-Link2-Pro Debugger and Programmer User Manual*.

#### 3.9.1 VCOM Switches

Table 3-17 presents how to set the VCOM function by ICESW2.

ICESW2		
Pin	Function	Description
1	TXD	<b>On:</b> Connect target chip PD.1 (UART0_TXD) to Nu-Link2-Me. <b>Off:</b> Disconnect target chip PD.1 (UART0_TXD) to Nu-Link2-Me.
2	RXD	<b>On:</b> Connect target chip PD.0 (UART0_RXD) to Nu-Link2-Me. <b>Off:</b> Disconnect target chip PD.0 (UART0_RXD) to Nu-Link2-Me.
<b>Note:</b> Pin 3 and 4 is unused.		

Table 3-17 VCOM Function of Nu-Link2-Me

3.9.2 Status LEDs

Table 3-16 presents the status LEDs patterns for different operation on Nu-Link2-Me.

Operation Status	Status LED			
	ICES0	ICES1	ICES2	ICES3
Boot	Flash x 3	Flash x 3	Flash x 3	Flash x 3
Idle	On	-	-	-
One Nu-Link2-Me is selected to connect	Flash x 3	Flash x 3	Flash x 3	On
ICE online (Not connected to a target chip)	On	-	Flash x 3	Flash x 3
ICE online (Connected to a target chip)	On	-	-	On
ICE online (Failed to connect to a target chip)	On	Any	Flash	On
During offline programming	-	On	-	Flash
Offline programming completed	On	-	-	-
Offline programming completed (Auto mode)	On	On	-	-
Offline programming failed	On	Flash	-	-
<b>Note:</b> "Online" means Nu-Link2-Me is connected to ICP Programming Tool, IDE or NuTool.				

Table 3-18 Operation Status LED Patterns

## 4 QUICK START

### 4.1 Toolchains Supporting

Install the preferred toolchain. Please make sure at least one of the toolchains has been installed.

- [KEIL MDK Nuvoton edition M0/M23](#)
- [IAR EWARM](#)

### 4.2 Nuvoton Nu-Link Driver Installation

Download and install the latest Nuvoton Nu-Link Driver.

- Download and install [Nu-Link Keil Driver](#) when using Keil MDK.
- Download and install [Nu-Link IAR Driver](#) when using IAR EWARM.

Please install the Nu-Link USB Driver as well at the end of the installation. The installation is presented in Figure 4-1 and Figure 4-2.

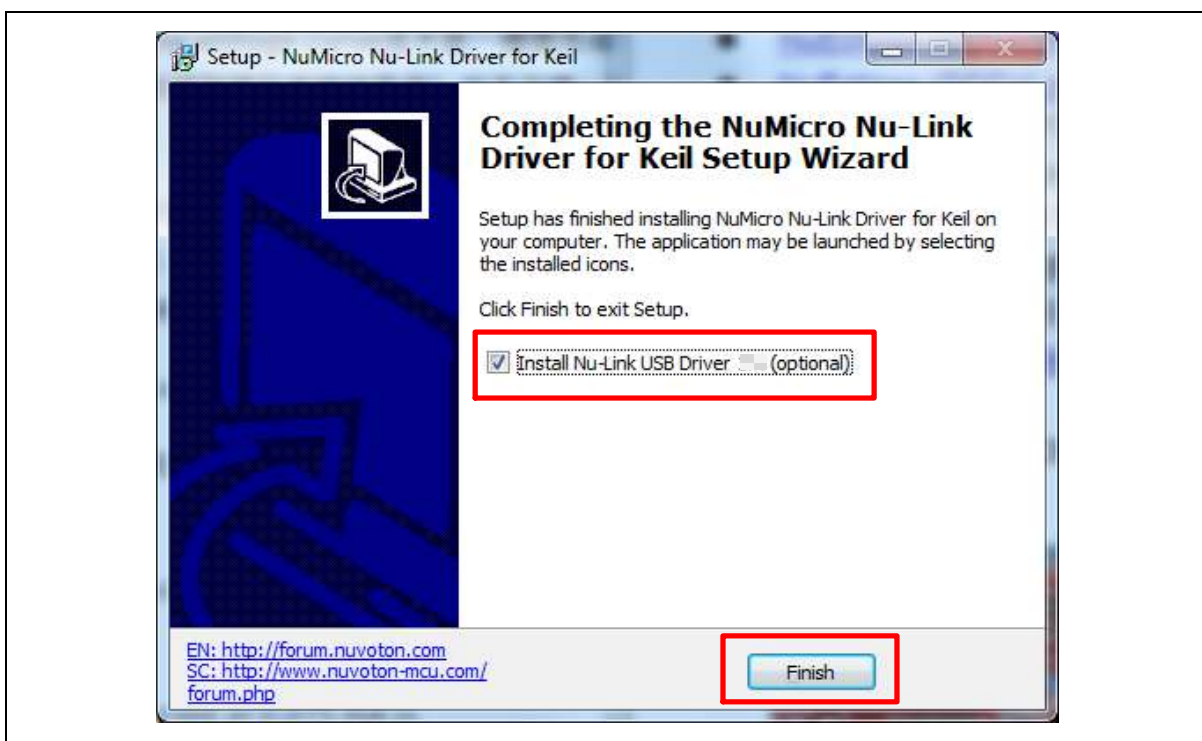

Figure 4-1 Nu-Link USB Driver Installation Setup





Figure 4-2 Nu-Link USB Driver Installation

### 4.3 BSP Firmware Download

Download and unzip the [Board Support Package \(BSP\)](#).

### 4.4 Hardware Setup

1. Open the virtual COM (VCOM) function by changing Nu-Link2-Me VCOM Switch No. 1 and 2 to ON.

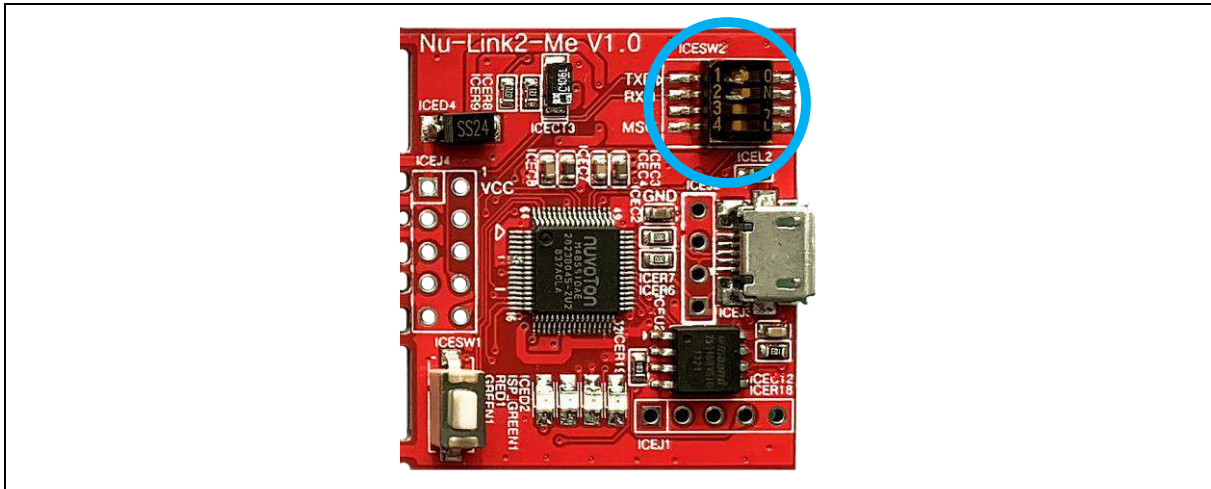

Figure 4-3 Open VCOM Function

2. Connect the ICE USB connector shown in Figure 4-4 to the PC USB port through a USB cable.

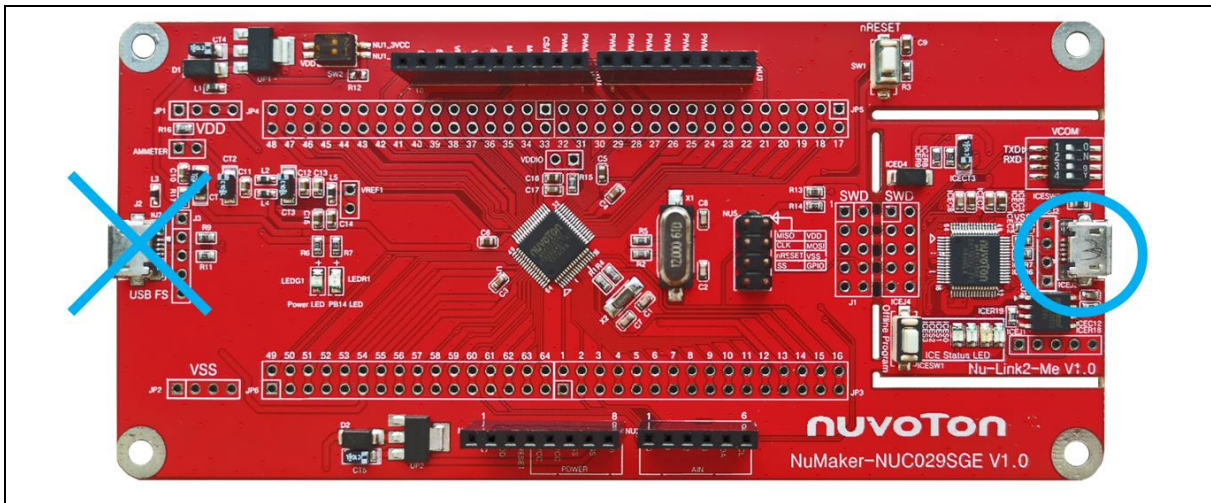

Figure 4-4 ICE USB Connector

3. Find the “Nuvoton Virtual COM Port” on the Device Manger as Figure 4-5.

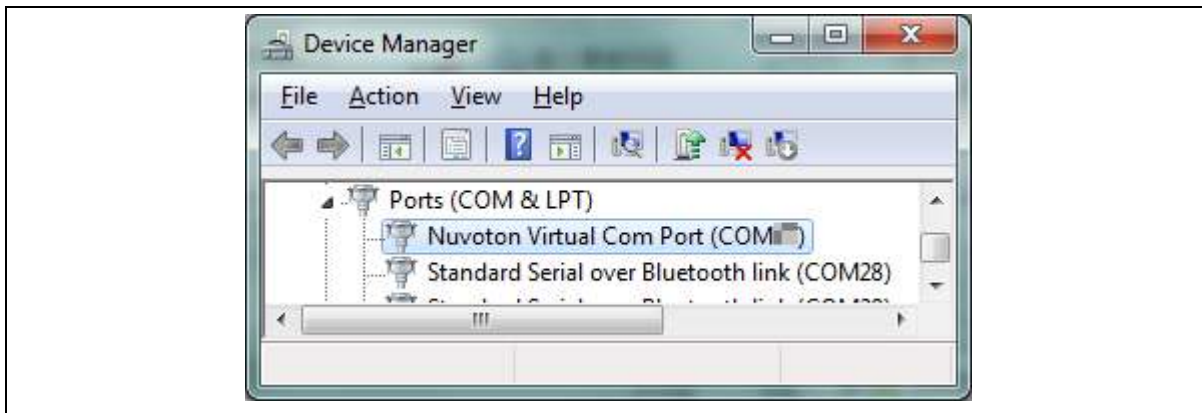

Figure 4-5 Device Manger

4. Open a serial port terminal, PuTTY for example, to print out debug message. Set the speed to 115200. Figure 4-6 presents the PuTTY session setting.

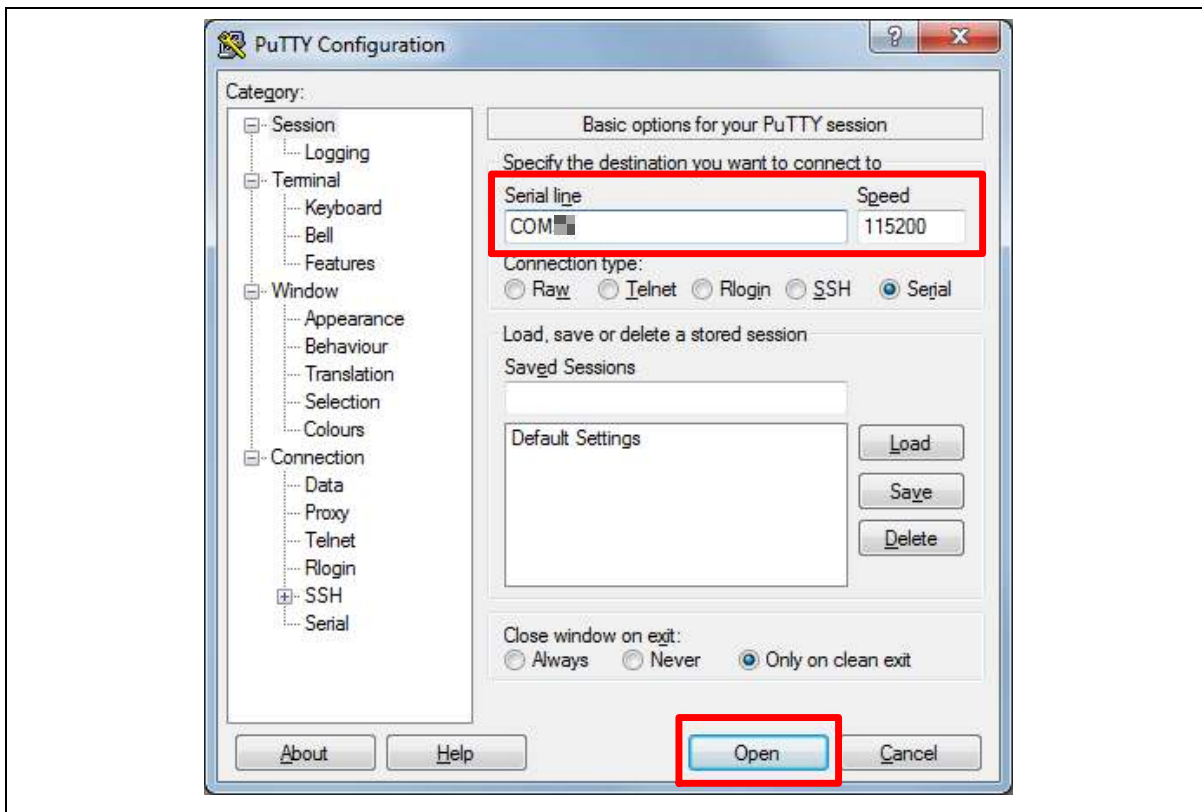

Figure 4-6 PuTTY Session Setting

### 4.5 Find the Example Project

Use the “Template” project as an example. The project can be found under the BSP folder as shown in Figure 4-7.

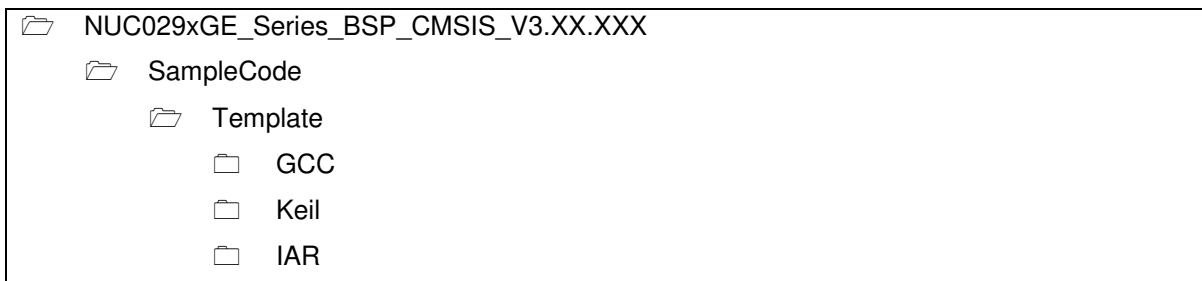

Figure 4-7 Template Project Folder Path

### 4.6 Execute the Project under Toolchains

Open and execute the project under the toolchain. The section 4.6.1 and 4.6.2 describe the steps of executing project in Keil MDK and IAR EWARM, respectively.

#### 4.6.1 Keil MDK

This section provides steps to beginners on how to run a project by using Keil MDK.

1. Double-click the “Template.uvproj” to open the project.



Figure 4-8 Warning Message of “Device not found”

**Note:** If Figure 4-8 warning message jumps out, please migrate to version 5 format as shown in Figure 4-9. The “.uvproj” filename extension will change to “.uvprojx”.

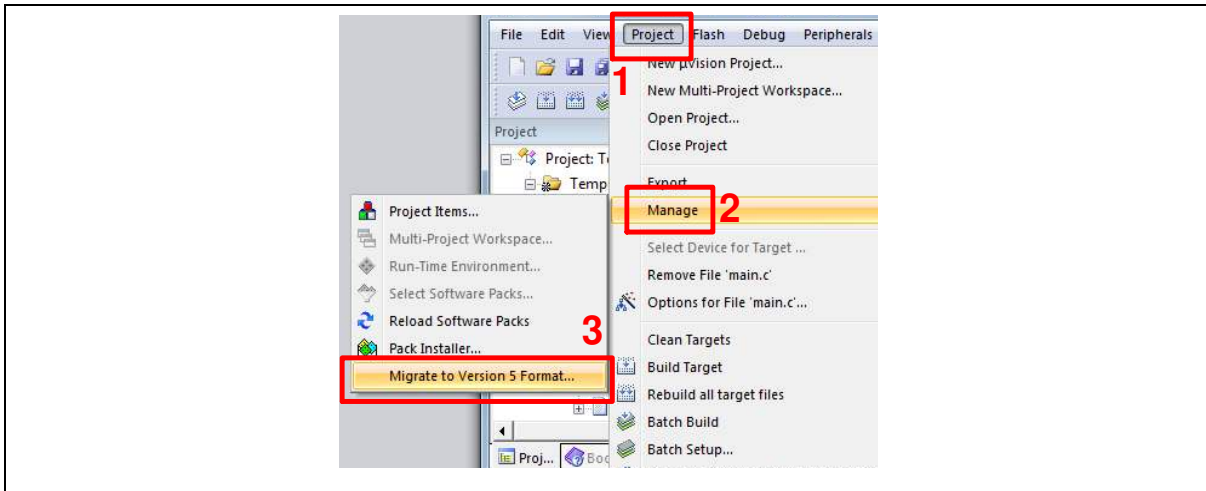

Figure 4-9 Project File Migrate to Version 5 Format

2. Make sure the debugger is “Nuvoton Nu-Link Debugger” as shown in Figure 4-10 and Figure 4-11.

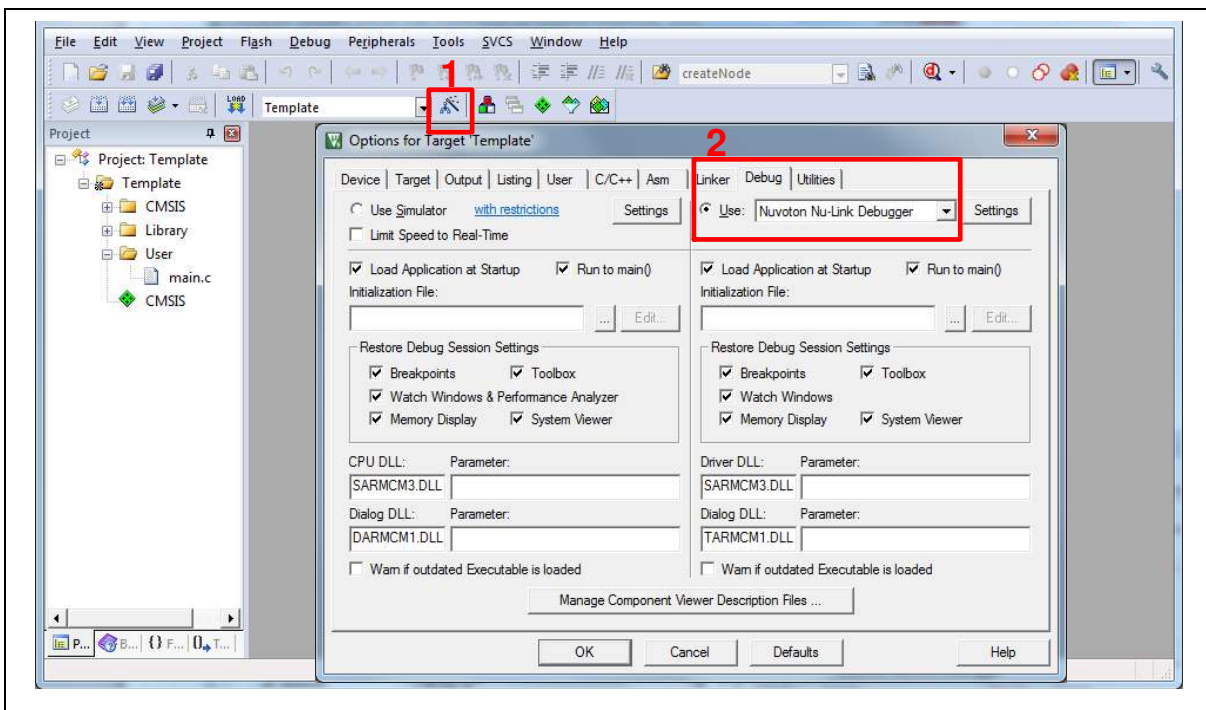

Figure 4-10 Debugger Setting in Options Window

**Note:** If the dropdown menu in Figure 4-10 does not contain “Nuvoton Nu-Link Debugger” item, please rework section 4.2.

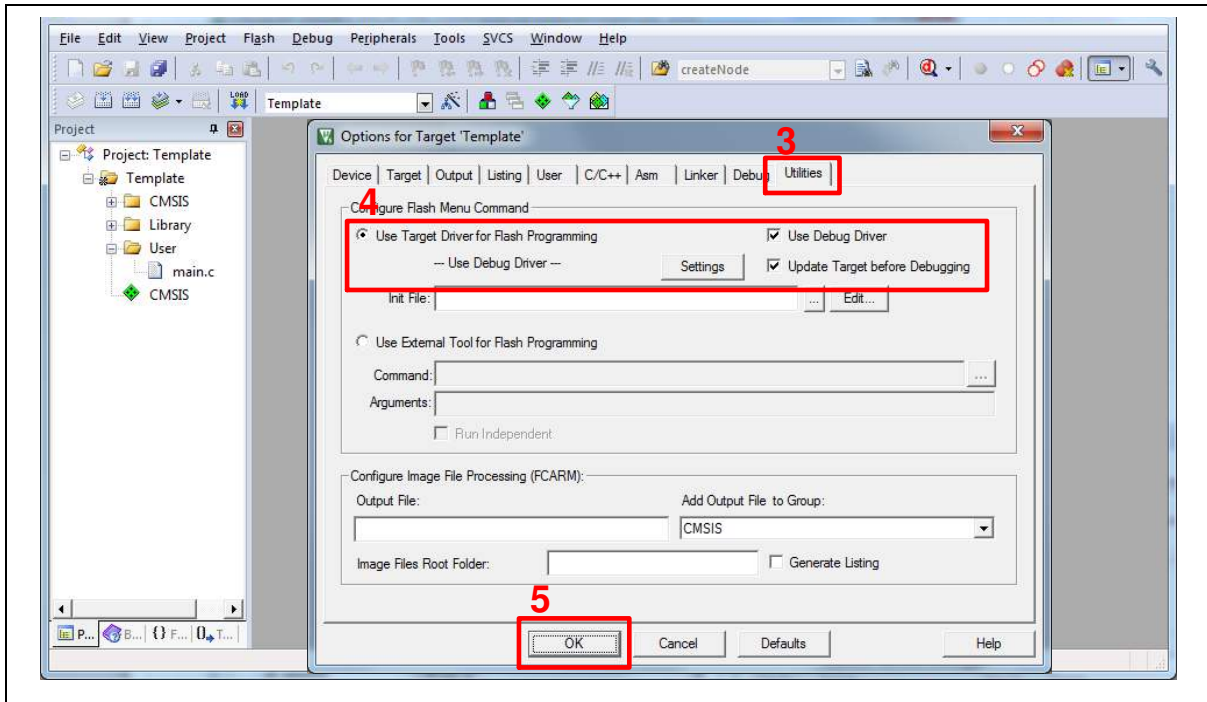

Figure 4-11 Programming Setting in Options Window

3. Rebuild all target files. After successfully compiling the project, download code to the Flash memory. Click **“Start/Stop Debug Section”** button to enter debug mode.

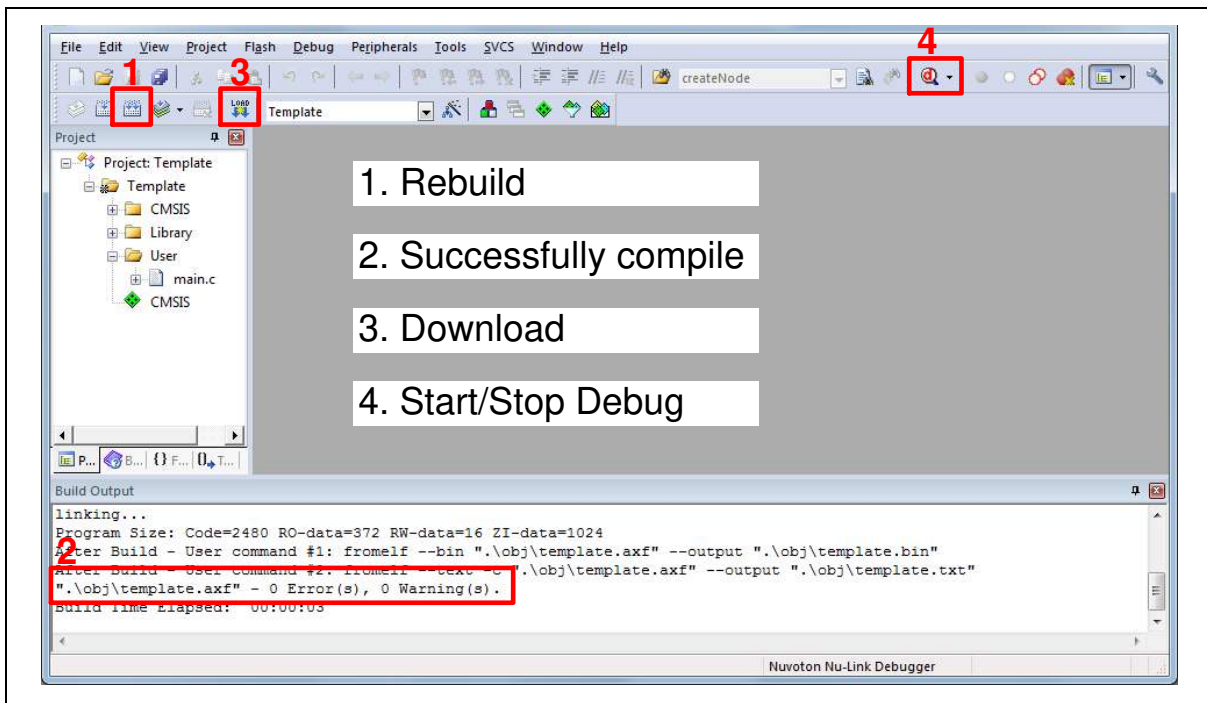

Figure 4-12 Compile and Download the Project

- 4. Figure 4-13 shows the debug mode under Keil MDK. Click “Run” and the debug message will be printed out as shown in Figure 4-14. User can debug the project under debug mode by checking source code, assembly language, peripherals’ registers, and setting breakpoint, step run, value monitor, etc.

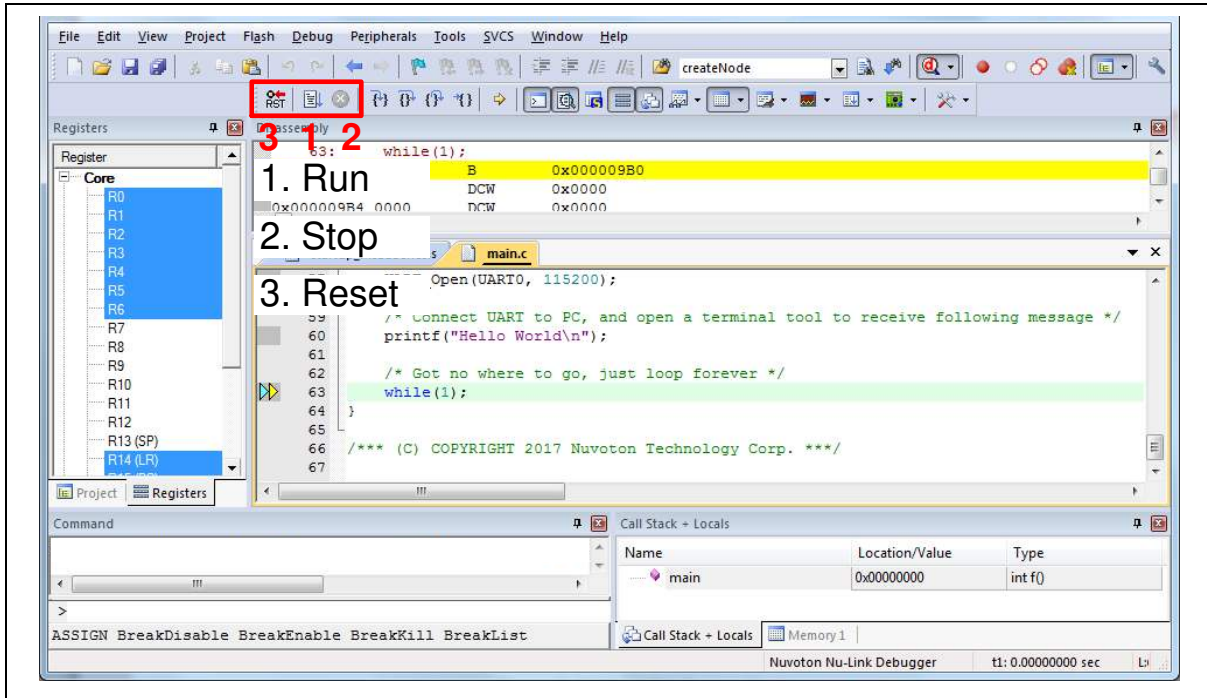

Figure 4-13 Keil MDK Debug Mode



Figure 4-14 Debug Message on Serial Port Terminal Windows

### 4.6.2 IAR EWARM

This section provides steps to beginners on how to run a project by using IAR EWARM.

1. Double click the “Template.eww” to open the project.
2. Make sure the toolbar contains “Nu-Link” item as shown in Figure 4-15.

**Note:** If the toolbar does not contain “Nu-Link” item, please rework section 4.2.

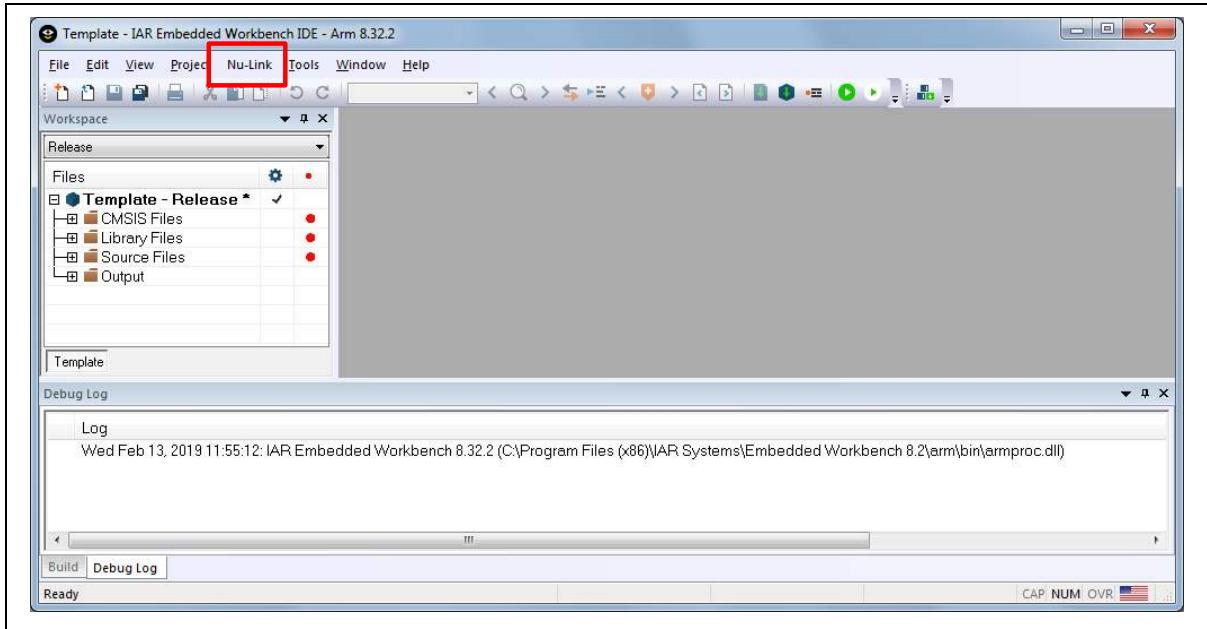

Figure 4-15 IAR EWARM Window

3. Make a target file as presented in Figure 4-16. After successfully compiling the project, download code to the Flash memory and enter debug mode.

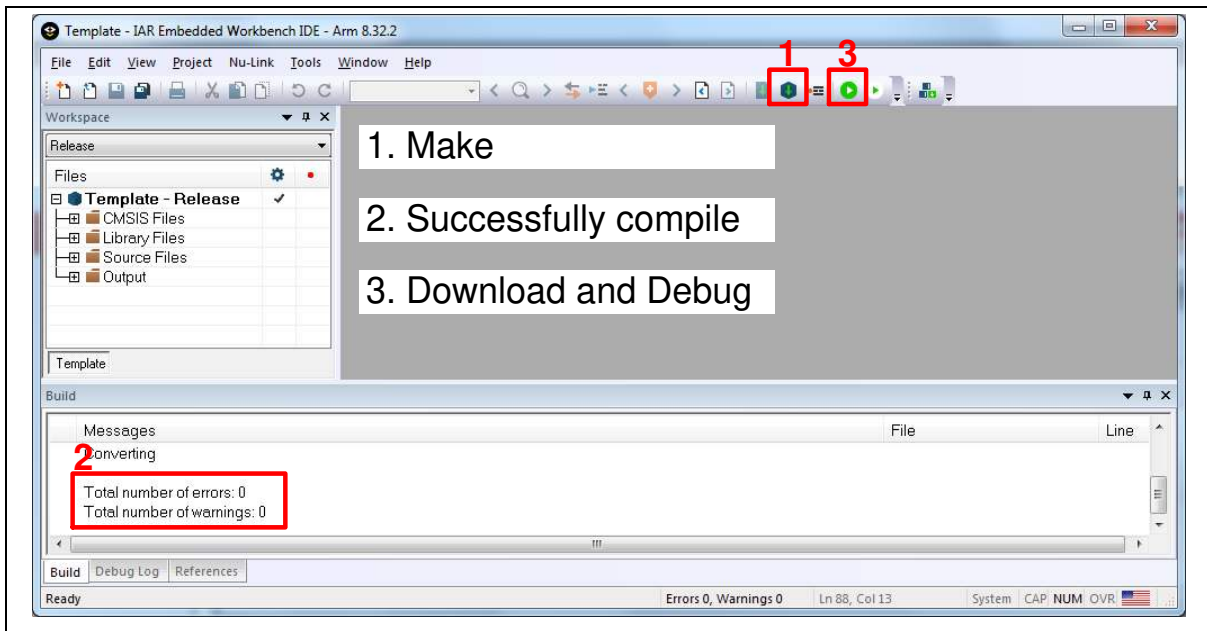

Figure 4-16 Compile and Download the Project



- 4. Figure 4-17 shows the debug mode under IAR EWARN. Click “Go” and the debug message will be printed out as shown in Figure 4-18. User can debug the project under debug mode by checking source code, assembly language, peripherals’ registers, and setting breakpoint, step run, value monitor, etc.

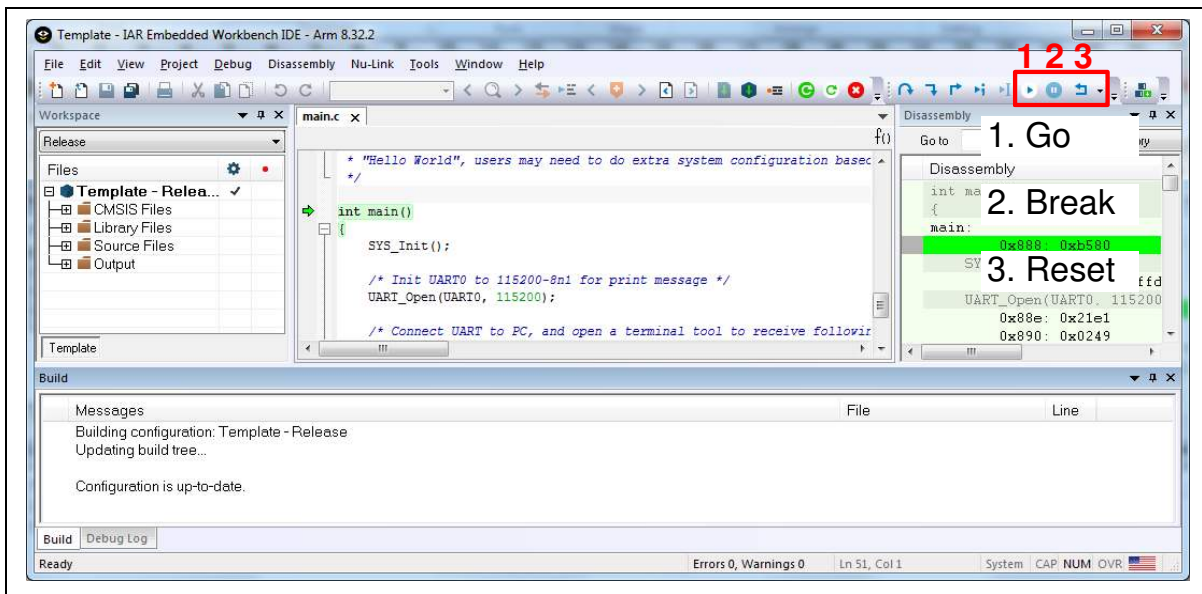

Figure 4-17 IAR EWARM Debug Mode



Figure 4-18 Debug Message on Serial Port Terminal Windows

## 5 NUMAKER-NUC029SGE SCHEMATICS

### 5.1 Nu-Link2-Me

shows the Nu-Link2-Me circuit.

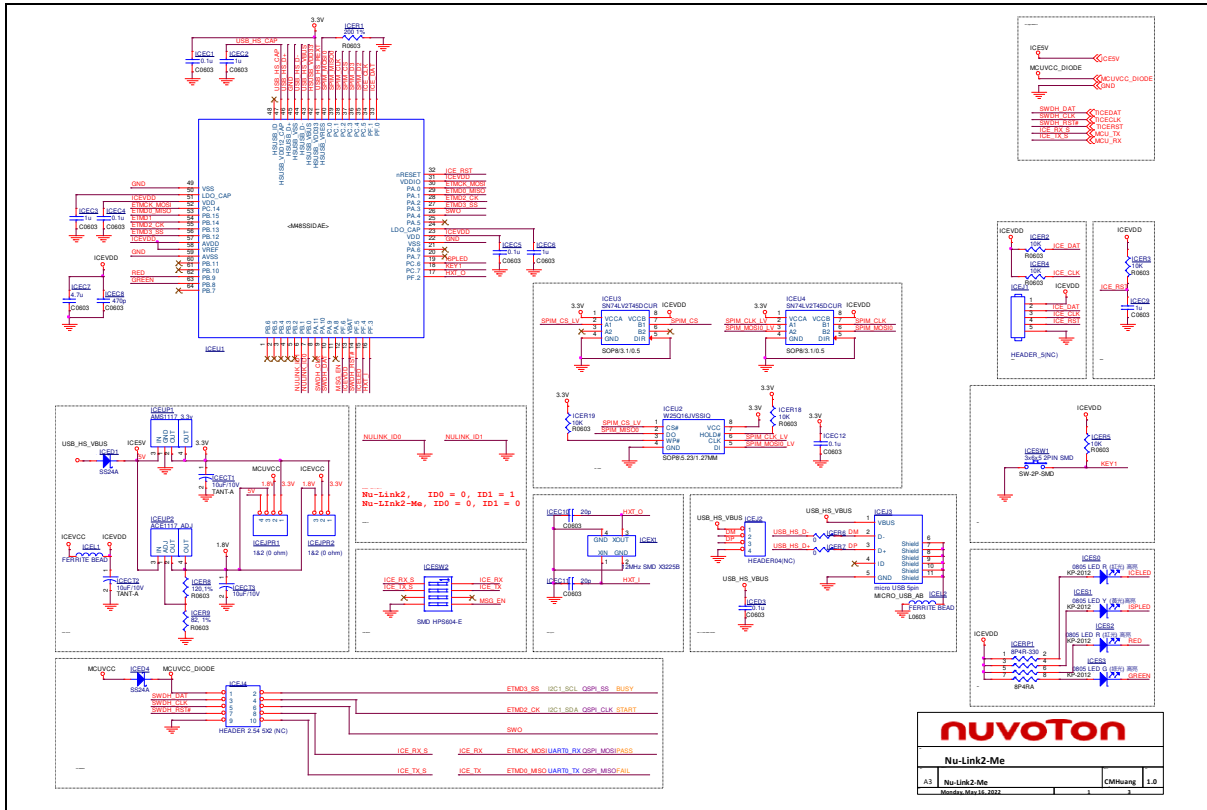

Figure 5-1 Nu-Link2-Me Circuit



### 5.3 Extension Connectors

shows extension connectors of NuMaker-NUC029SGE.

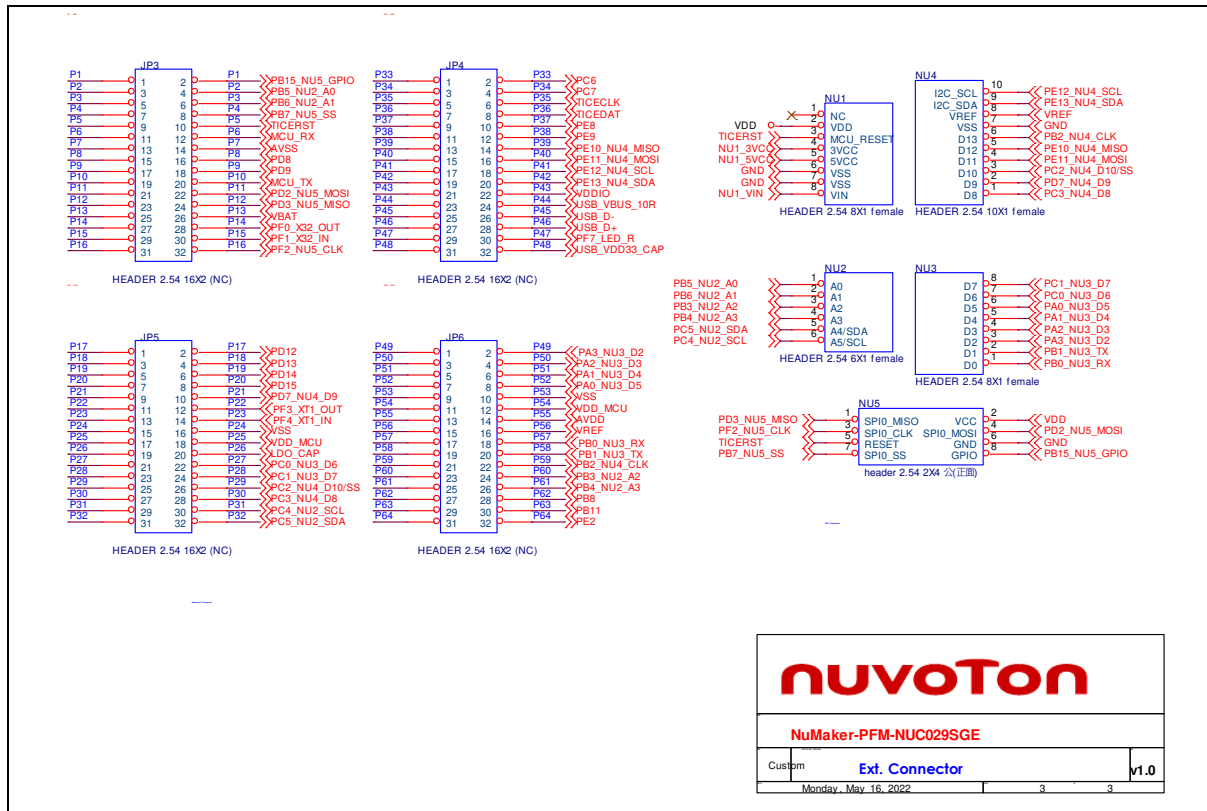

Figure 5-3 Extension Connectors Circuit

<b>nuvoTon</b>		
<b>NuMaker-PFM-NUC029SGE</b>		
Custom	<b>Ext. Connector</b>	<b>v1.0</b>
Monday, May 16, 2022	3	3

5.4 PCB Placement

and show the front and rear placement of NuMaker-NUC029SGE.

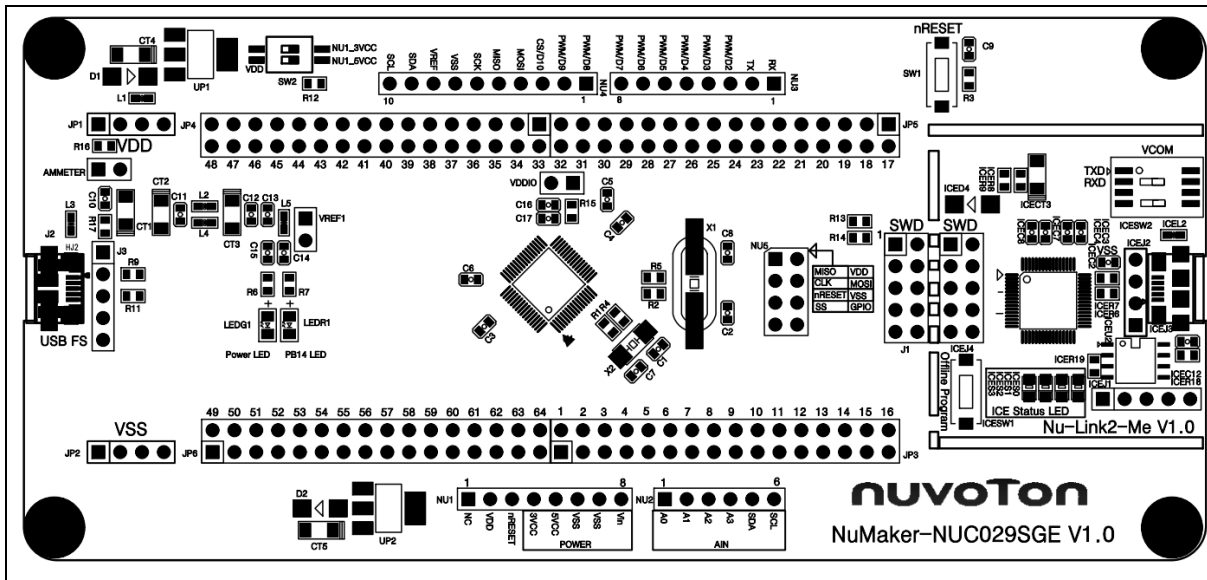

Figure 5-4 Front Placement

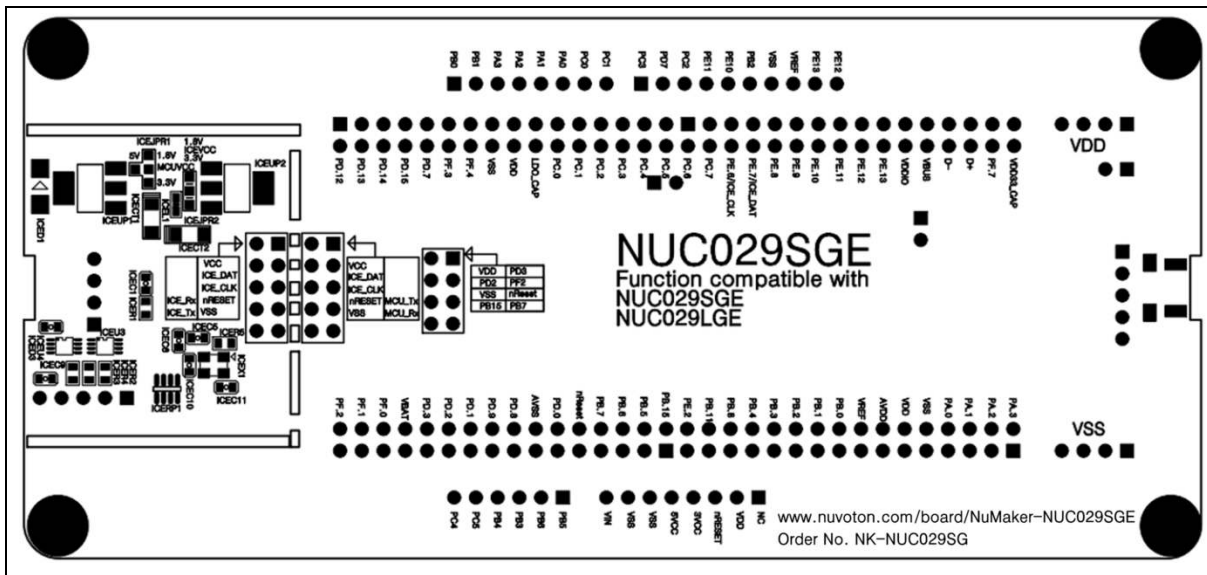

Figure 5-5 Rear Placement

**6 REVISION HISTORY**

Date	Revision	Description
2022.07.20	1.00	Initial version.

### Important Notice

**Nuvoton Products are neither intended nor warranted for usage in systems or equipment, any malfunction or failure of which may cause loss of human life, bodily injury or severe property damage. Such applications are deemed, “Insecure Usage”.**

**Insecure usage includes, but is not limited to: equipment for surgical implementation, atomic energy control instruments, airplane or spaceship instruments, the control or operation of dynamic, brake or safety systems designed for vehicular use, traffic signal instruments, all types of safety devices, and other applications intended to support or sustain life.**

**All Insecure Usage shall be made at customer’s risk, and in the event that third parties lay claims to Nuvoton as a result of customer’s Insecure Usage, customer shall indemnify the damages and liabilities thus incurred by Nuvoton.**

---

*Please note that all data and specifications are subject to change without notice.  
All the trademarks of products and companies mentioned in this datasheet belong to their respective owners.*